

No	Item	Specification
1	Compressor	MTZ125 (Maneurop)
2	Condenser	3 Row
3	Fan Motor	2 x 500mm (EBM)
4	Receiver	14.5L (TEM)
5	Oil Separator	7/8" (Castel)
6	Suction Line Strainer	1 1/8" (Henry/Heldon)
7	Filter Drier	5/8" (Danfoss)
8	Sight Glass	5/8" (Castel)
9	Solenoid Valve	5/8" (Danfoss)
10	Fan Speed Control	Carel
11	Electrical Box	TEM
12	Pressure Switch	KP15 060-183491 (Danfoss)

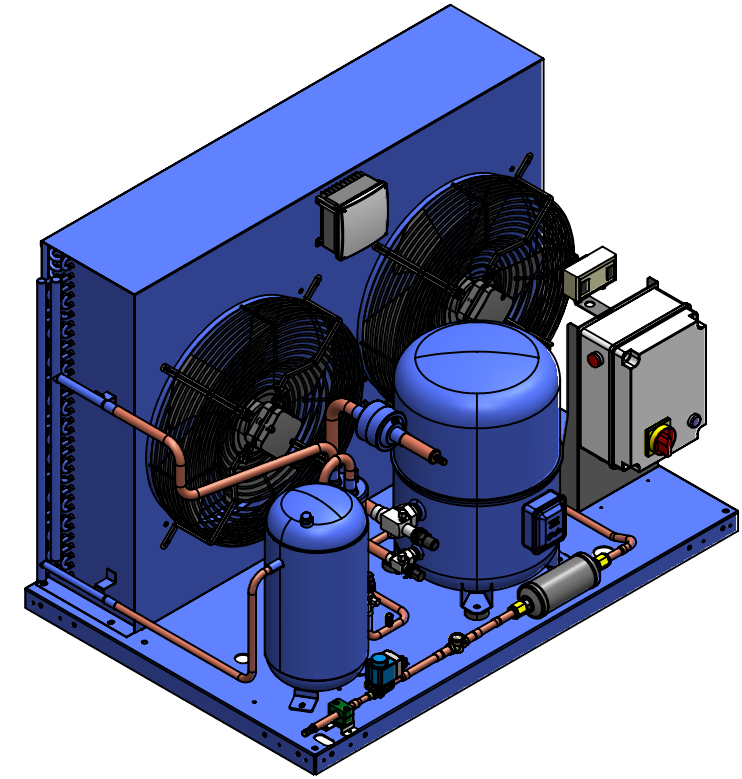

9	J	Change Suction line strainer.	19/02/20	rudy	Ijat	Sham
8	H	Change pressure switch.	12/02/20	rudy	Ijat	Sham
7	G	Change electrical box.	31/10/19	rudy	Ijat	Sham
6	F	Change model name.	07/10/19	rudy	Ijat	Sham
No.	Ind	Modification	Date	Drawn	Checked	Approved

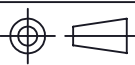

Model	GH209MHA1-2	Drawn	rudy
Description	Condensing Unit	Checked	Ijat
Drawing No.	TEM19/CU/005	Approved	Sham
Date	18/01/2019	Index	J

TECUMSEH EURO-MALAYSIA SDN BHD