

Data sheet

AB-QM 4.0 Flexo, DN 15-20, PN 25

Description



Danfoss AB-QM 4.0 Flexo with AB-QM valve is a compact and time saving connection set – designed for creating optimal hydronic balance in cooling and heating applications with variable flow (such as fan coil units (FCU) or chilled beams). Flow is controlled by the AB-QM pressure independent control valve to avoid overflow and reduced efficiency of thermal unit.

Benefits: Installation

- Saving time and space
- Pre-assembled design

Reduced installation time
Easy setting and sizing, 100% authority and perfect control.

Trouble-free installations

- Compact and space saving installation
- Pressure tested from factory - Nominal pressure PN25

Service

Enable fast servicing, maintenance and trouble shooting

- Easy flushing
- Easy draining
- Easy bypass
- Easy cleaning of filter
- Enables pressure and flow validation

Energy efficiency

Pressure independent flow control with AB-QM 4.0
Improved indoor comfort with best performance and energy savings. Efficient energy transfer and minimal pumping costs.

Applications

AB-QM 4.0 Flexo is a pre-assembled, pressure tested set used for terminal units, such as FCU (Fan Coil Unit). The Danfoss AB-QM 4.0 Flexo solution comprises a H-body (with integrated shut-off valves, measuring plug, strainer valve with integrated drain function, handles, fittings, etc.) and associated Danfoss AB-QM 4.0 pressure independent control valve.

The AB-QM ensures and controls the required flow on every terminal unit and maintains Hydronic balance in the system.

The control valve has 100% authority and therefore always ensures stability of control. At partial load there is no overflow, contrary to conventional solutions, because the AB-QM will always limit the flow to exactly what is needed. By installing the AB-QM the whole system is divided in completely independent control loops.

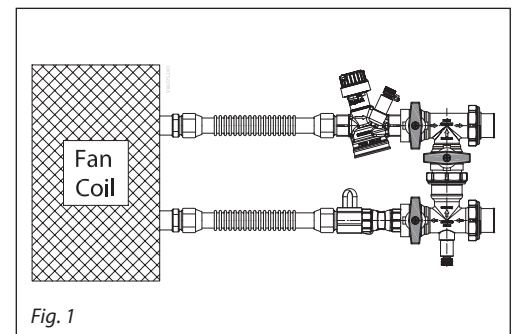

Fig. 1

There is a full range of Danfoss actuators available for the AB-QM 4.0, suitable for every control strategy. Actuators* are available for On/Off, 0-10 Volt, 4-20 mA and digital via field bus.

* for more details see AB-QM data sheet & actuators.

Ordering

AB-QM 4.0 Flexo with AB-QM valve:

Type	Connection	Centre (mm)	Code No.
			with extended handle
DN15 LF	Rp ½	111.5	003Z1619
DN15			003Z1615
DN15 HF			003Z1616
DN20	Rp ¾		003Z1617
DN20 HF			003Z1618

Description	Dimension	Material	Comments	Code No.
AB-QM 4.0 Flexo Insulation	DN15	EPP		003Z4791
	DN20	EPP		003Z4792
AB-QM 4.0 Flexo flexible pipe	DN15	SS	set of 2 pcs	003Z4794
	DN20	SS	set of 2 pcs	003Z4795
Flexo extended handle (sparepart)	DN15-DN20		Black	003Z4797

For complete range of AB-QM actuators, accessories and spare parts please refer to AB-QM data sheet.

Specifications

Nominal diameter		DN	15 LF	15	15 HF	20	20 HF
Flow range	Q _{nom} (100 %) ¹⁾	l/h	200	650	1.200	1.100	1.900
Setting range ^{1), 2)}		%	10-100				
Diff. pressure ³⁾	Δp_{min} ⁴⁾	kPa	16	16	25	16	25
	Δp_{max}		600				
kvs ⁵⁾		m ³ /h	1.5			3.5	
Pressure stage		PN	25				
Control range			1:1000				
Control valve's characteristic			Linear				
Leakage acc. to standard IEC 534			No visible leakage (at 100N)				
For shut off function			Acc. to ISO 5208 class A - no visible leakage				
Flow medium			Water and water mixture for closed heating and cooling systems according to plant type I for DIN EN 14868. When used in plant Type II for DIN EN 14868 appropriate protective measures are taken. The requirements of VDI 2035, part 1 + 2 are observed.				
Medium temperature		°C	-10 ... +95				
Stroke		mm	4				
Connection	Connection port		Rp 1/2			Rp 3/4	
	Actuator		M30 x 1.5				
Insulation							
Density		g/l	60				
Water absorption		%	1.2+-0.6				
Insulation property / thermal conductivity			39 mW/m/K				
Fire behaviour classification			Building, Euroclass E				
Flex pipe	Connection port		Rp 1/2" - Rp 1/2"			Rp 3/4" - Rp 3/4"	
Materials in medium							
Flexo H-piece	Body and connection	Brass (CW617N)					
	Strainer						
	Drain valve						
	Fittings, unions						
	Test plug						
	Gasket	PTFE					
Material out of medium							
Flexo H-piece	Operating handles	ABS					
	Handwheel screw	Brass					
Materials in medium							
PICV (AB-QM)	Valve bodies	DZR Brass (CW602N)					
	Membranes and O-rings	EPDM					
	Springs	W.Nr. 1.4310					
	Spring support	PPSU					
	Shutter	DZR brass (CW602N)					
	Cone (Cv)	PPSU					
	Seat (Cv)	DZR brass (CW602N)					
	Screw	Stainless Steel (A2)					
Material out of medium							
PICV (AB-QM)	Plastic parts	PA 6					
Accessories							
Accessories	Insulation	EPP					
	Flexible pipe	Stainless steel (1.4404)					
	Union	Stainless steel (1.4305)					
	Nut	Brass (CW617N)					
	Gasket	NBR					

¹⁾ Factory setting of the valve is done at nominal setting range.

²⁾ Regardless of the setting, the valve can modulate below 1 % of set flow.

³⁾ At min differential pressure valve reaches at least 90% of nominal flow. Declaration of performance is available upon request.

⁴⁾ AB-QM 4.0

⁵⁾ Flexo connection set without AB-QM 4.0

According suitability and usage especially in not oxygen tight systems please mind the instructions given by the coolant producer.

Pc - pressure controller part

Cv - Control valve part

Design

1. Pipe connection
2. Nut
3. Black handwheel (Bypass)
4. Handle screw
5. Inlet valve body
6. Test plug
7. Blue handwheel (Inlet)
8. 1/2" int. thread strainer
9. Drain connection
10. Union
11. AB-QM 4.0
12. Red handwheel (Return)
13. Return valve body

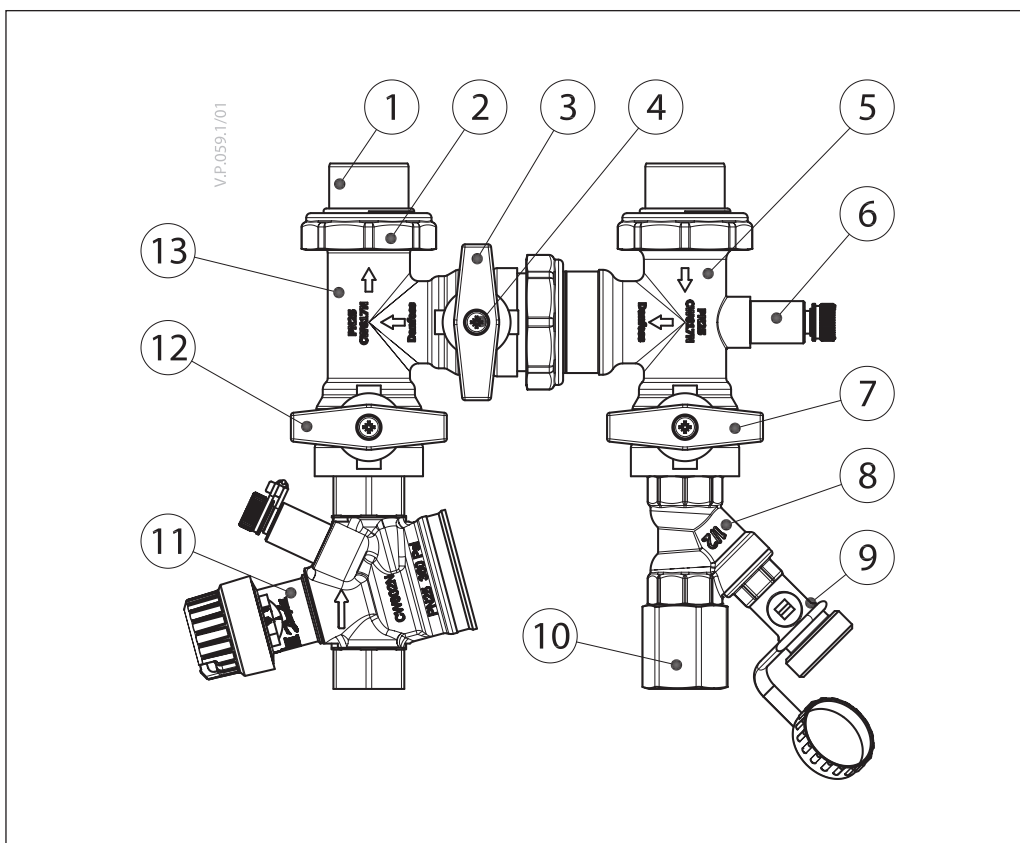

Presetting

The calculated flow can be adjusted easily on ABQM 4.0 without using special tools. The change of presetting (factory setting is 10) follow steps below:

1. Remove the blue protective cap or the mounted actuator
2. Turn the pointer (clockwise to decrease) to the new setting
3. The presetting scale indicates values from 10-0.
Clockwise turning would decrease the flow value while counter clock wise would increase it.

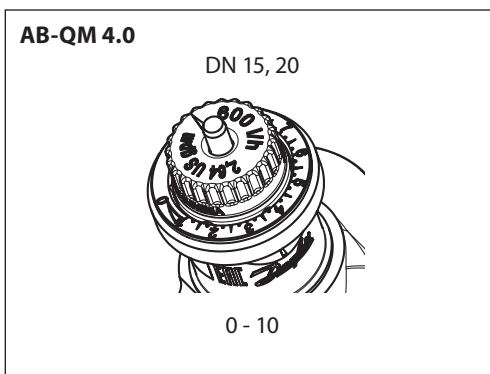

Installation

Small installation dimensions enable easy installation of Flexo connection set even in very limited space. PICV valve should be installed in the return pipe from the thermal unit with flow in the direction of the arrow on the AB-QM valve body.

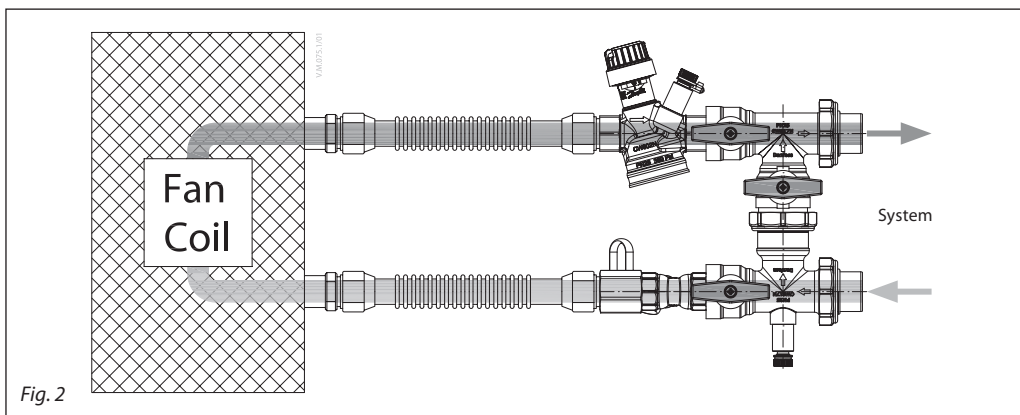

Note:
The connection set can be installed in both cooling and heating applications. From factory handle colors are mounted for cooling according to flow direction arrows on set. Color handles can be interchanged on site.

Sizing

Example:

Given:
 Design flow in system 0.2 l/s (0,72m³/h = 720l/h),
 Solution:
 In this case we can select AB-QM 4.0 DN15HF
 (Fig.2) with Q_{nom} = 1200 l/h AB-QM and
 presetting.
 Setting on the valve AB-QM DN 15 HF is design
 flow divided by nominal valve capacity, 720 l/h
 divided by 1200 l/h = 60 %.

Flushing

There are three basic modes during flushing:

Forward flushing and draining

of system should be done via drain connection (integrated in strainer valve). Use the following
 procedure to drain via strainer valve (Fig. 3):

1. Connect pipe on drain connection
2. Close shut-off valve ① on PICV side and close bypass shut-off valve ②
3. Open shut-off valve ③
4. Open shut-off valve on strainer valve ④
5. Drain the system

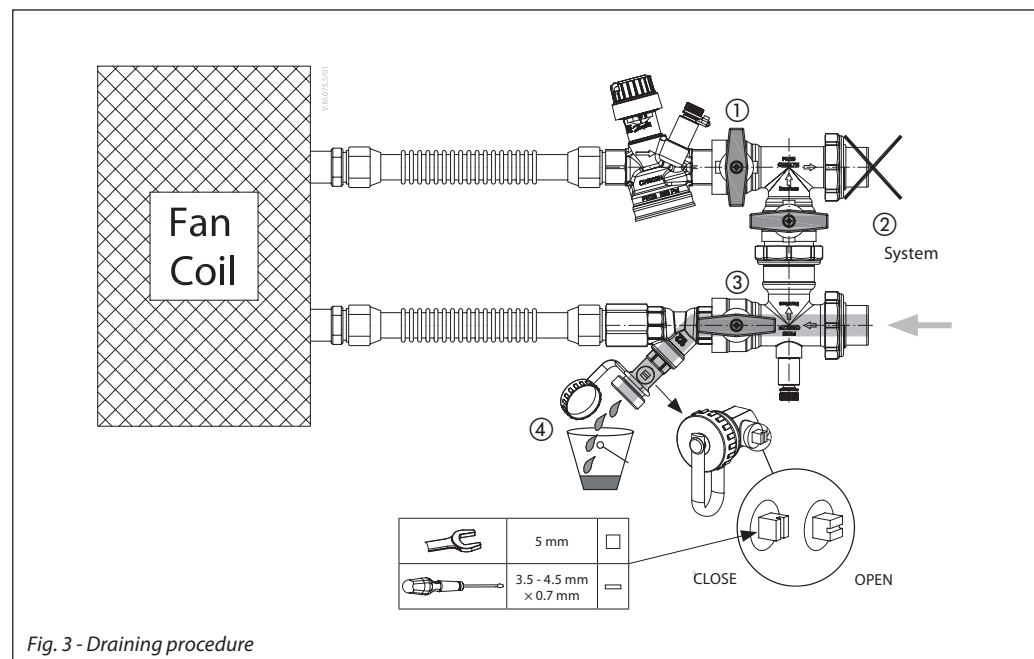

Flushing *(continuous)*

Flushing of main pipe

High level of cleanliness of main pipe network flushing is achievable, since thermal units are isolated. Use the following procedure for flushing main pipe via bypass pipe-line (Fig. 4):

1. Close shut-off valve ① on PICV side and close shut-off valve ③
2. Open shut-off valve ②
3. Close shut-off valve on strainer valve ④
4. Start with flushing procedure

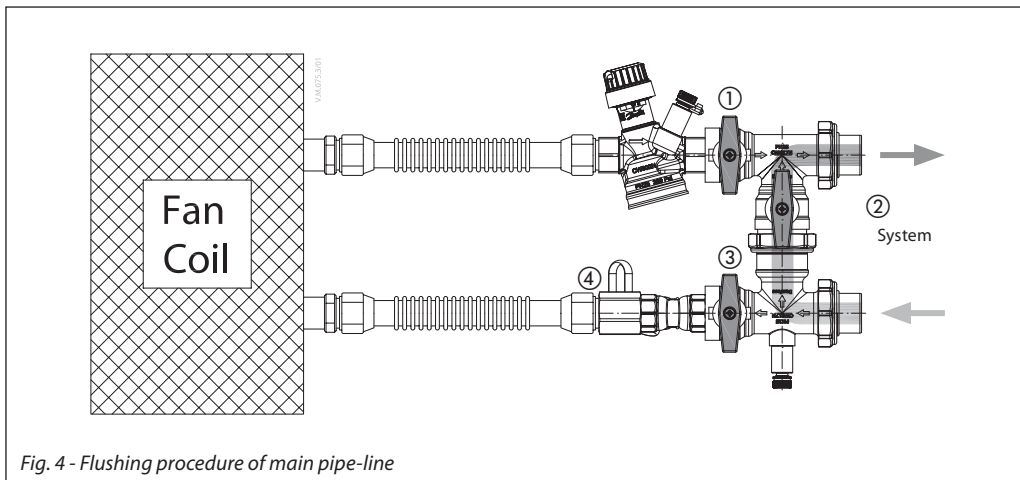

Backward flushing and draining

Offers cleaning of thermal unit. Backward flushing of fan coil should be done only with full open valve or full open actuator mounted on the valve. Use the following procedure for flushing main pipe via bypass pipe-line (Fig. 5):

1. Close shut-off valve ③
2. Open bypass shut-off valve ② and shut-off valve ① on PICV side
3. Open shut-off valve on strainer valve ④
4. Start with flushing procedure

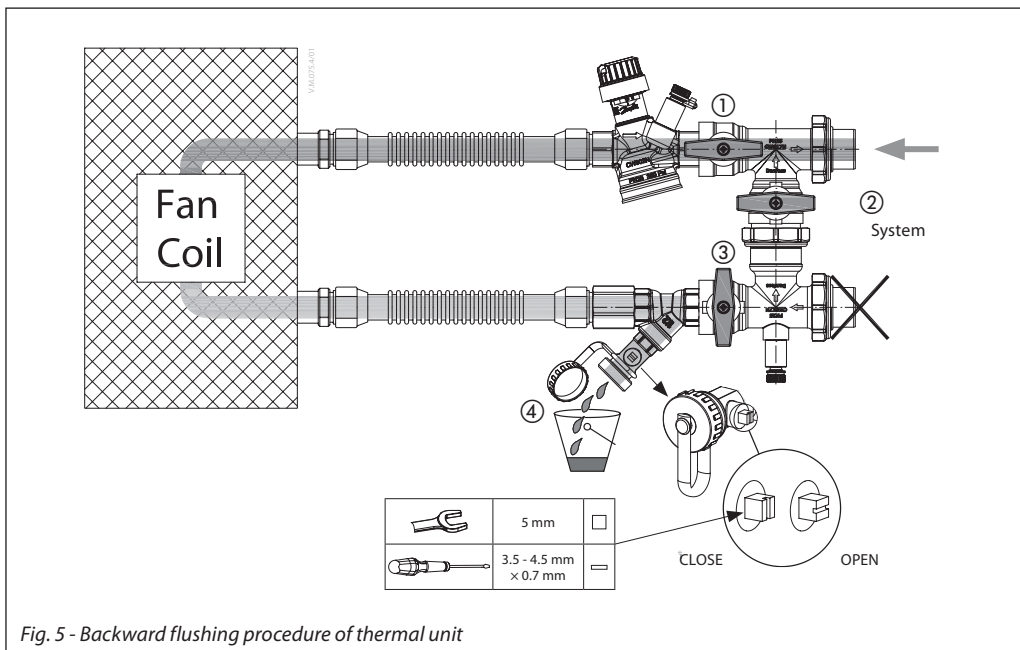

Tender text

The terminal units shall be connected to the system by way of a valve assembly. This valve assembly shall have the following characteristics:

- The valves set shall comprise of the following components, PICV, H-piece valve body, test plug, strainer valve with drain, operating handles.
- The assembly shall have a bypass line that, by manipulating the ball valves, will be able to insulate the terminal unit and PICV to allow forwards- and backwards flushing of the system
- The valve set shall have extended handles to allow operation with the insulation.
- It shall be possible to shut off the bypass
- The set shall be suitable for 25 Bars of static pressure (PN25)
- The set shall be leak tested
- If required the set shall be insulated by an EPP form-fitting shell
- The PICV shall have the following characteristics:
 - Flow limitation function
 - Modulating below 1% of set flow, regardless of the setting,
 - Authority of 1 at all settings
 - Able to close against 16 bar of differential pressure.
 - Linear control characteristic
 - Setting scale in percentage of flow
 - Control ratio 1:1000
 - Test plugs for pump optimization and flow measuring
 - Characteristic changed from linear to equal percentage characteristic at all sizes by adjusting actuator settings
 - Leakage rate Class IV

Dimensions

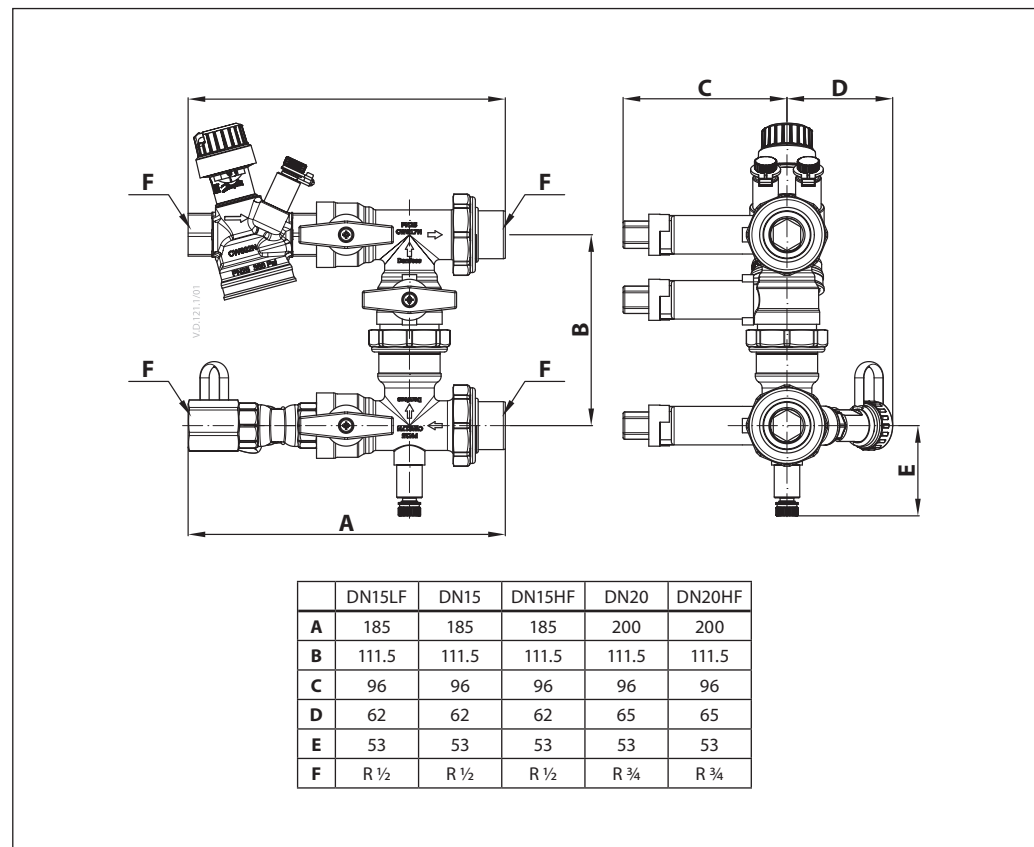

Dimensions (continuous)

