



Auspex

Universal Water and Gas Manual

2025



A TRADITION OF TRUST

auspex.com.au

About Auspex

Auspex was first introduced to plumbers in 1997 by the Bines family, revolutionising hot and cold-water installs with a comprehensive range of PE-X pipes and DZR Brass fittings, saving time, reducing waste and guaranteeing ease of installation.

Through its simple Cut, Crimp, Done connection method, Auspex has now been used by three generations of plumbers establishing a 'Tradition of Trust' throughout the plumbing industry.

Auspex plumbers over many years have been the driving force behind innovation and change, providing continual improvements throughout the Auspex system. An examples of this is with a wide range of PE-X, PB, Copper and >B< Press Adaptors, Auspex provides all plumbers a workable solution for any job.

In 2022 Auspex Gas was launched adopting a one fitting solution in sizes 16-32mm for both water and gas applications. Adopting a universal DZR brass fitting for both water and gas has provided plumbers versatility, flexibility and convenience for getting jobs done.

As an extension to this 'One fitting solution' concept, Auspex is currently leading the plumbing industry by introducing 'Lead Free (LF)' brass fittings ahead of the May 2026 legislative requirements for all drinking water installations.

Complementing the one LF fitting solution for both water and gas installations, Auspex has extended its pipe and fitting range beyond its traditional 16, 20, 25 and 32mm PE-X pipe sizes to offer a broader plumbing industry solution.



Auspex Water 082M DN32 x

CONTENTS

About Auspex	2
Advantages of Auspex Crimp System	4
Auspex Design	6
Auspex Product Design	8
Auspex Pipes	11
Auspex Stainless Steel Range	24
Installation Instructions	26
General Installation Tips	27
Troubleshooting	29
Multi-Layer Pipe	31
Multi-Layer Water Pipe	32
Water Pressure Loss	38
Making A Joint	41
Multi- Layer Gas Pipe	42
Making A Joint	46
Troubleshooting	48
Pipe Sizing	49
Flow tables	50
Manual Crimping Tool	56
Joining To Other Materials	57
PE-X Pipe	59
Muti-Layer Pipe Water and Gas	61
Fittings	62
Tooling	70
Tooling	71
Stainless Steel Fittings	72
Stainless Steel Fittings	73
Questions and Answers	74
Notes	82



3.9 Class 2/10Bar PE-Xb/HD

The Auspex Crimp System, made for both cold and hot water applications, has passed the test of time in Australia since 1997, thanks to its 'cut, fit, crimp, done' process.

The crimp system comprises PE-X pipe, LF DZR brass fittings, copper crimp rings and a specially engineered jointing tool, ensuring that all your jobs are quick, hassle free, cost effective and of the highest quality. The fittings are manufactured and tested to comply with the performance requirements of AS/NZS 2537, AS 2492 and AS 4176.

Auspex are constantly working to improve the crimp system to make it as user-friendly for plumbers as possible.

Advantages of Auspex Crimp System

1. Installed and trusted by plumbers since 1997 establishing a 'Tradition of Trust'
2. Fast and simple installation
3. Reliable, secure connection
4. One Lead Free DZR brass fitting solution for both Water and Gas applications.
5. Copper crimp ring across all fitting sizes providing a truly uniform system
6. Flexible, durable and strong, PN20 rated pipe, manufactured using PE-X100 material.
7. SDR9 PE-X pipes providing improved flow rates over SDR7.4 PE-X.
8. Stainless Steel fitting range in 16-25mm sizes for RO Water, Bore or various aggressive water conditions
9. PE-X and MLP pipes suitable for water, gas, heating, domestic sprinkler and HVAC applications.
10. Hand crimpers and battery tools suitable for various system applications
11. Rolled copper crimp rings permanently part of 16-25mm fittings.
12. Holding rings providing secure copper crimp rings for 32-63mm fittings
13. Protective caps in all Auspex fittings for added security
14. Pipe insertion depth confirmed with viewing windows
15. Approved for behind the wall and underground applications
16. Quality engineered in Australia
17. Extensive range of adaptor fittings providing easy transition between Cu, PB, PE-X systems, B Press Adaptors



DID YOU KNOW?

Most Auspex fittings are universal, and can therefore be used in water, fire, and gas applications. Please refer to the Auspex Fittings Product Guide for further information, by scanning the QR code.



01 SMK41080



Auspex Design

Auspex fittings incorporate a number of unique features.

Auspex Brass Design

16mm, 20mm and 25mm

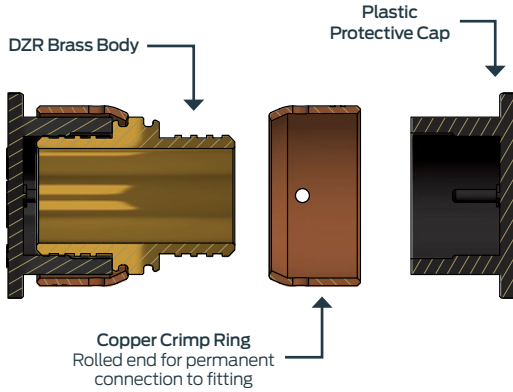

Auspex Brass Design

32mm, 40mm,
50mm and 63mm

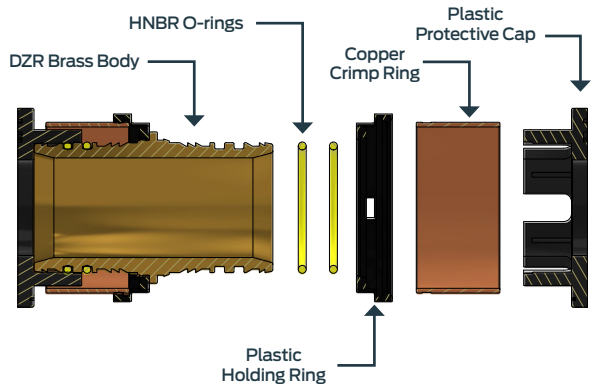

Auspex Stainless Steel Design

16mm, 20mm and 25mm

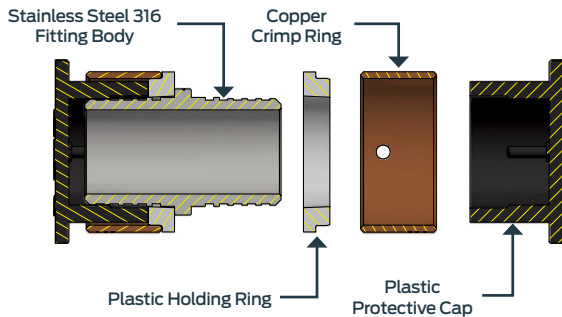

What's New

In 2022, Auspex launched a range of gas pipe and fittings for use in AS/NZS 5601 installations. Based on the success of that, RWC is bringing to market two new product lines:

- An extension of the range of GAS pipe and fittings from 40-63mm
- A range of Water MLP pipe and fittings from 16-63mm

The great thing about these additions to the Auspex Universal range is that they are compatible with the same fittings and tools already in place in the Auspex system and for DuoPEX users, the tooling and jaws used in 40-63mm sizes will work on Auspex fittings.

There are now two designs of fittings:

- Classic Auspex Fittings - 16-25mm, copper ring connected directly to the brass body with a colour coded protection cap
- Large Bore Fittings 32-63mm, use a colour coded ring and protection cap

The products are all Watermark certified as Lead-Free and new fittings in sizes 32-63mm will be supplied with a new design gear-shaped protection cap.

REMEMBER: 32mm pipe now has to be deburred before installation, both PE-X and MLP - just like 40-63mm fittings as they all include dual O-ring protection system.

Plastic Rings and Caps

Mk II Auspex has been designed with captive copper ring technology to improve the installation experience, however there are still protection caps and there are some rings used in the range.

Protection Cap 16-25mm

The Auspex range includes a protective cap to prevent damage to the copper crimp ring.

- Black for universal installation
- Blue for water installation only
- Yellow for gas installation only

Plastic Holding Ring 16-25mm

While most fittings within the Auspex range from 16 to 25mm utilise the captive copper crimp ring technology, there are some applications where a removable crimp ring is advantageous. For these products a plastic retainer ring is used to hold the crimp ring to the fitting. It plays no part in the integrity of the joint.

Plastic Sight Ring 32-63mm

In the large bore range (32-63mm), there is a plastic sight ring which serves several functions:

- As a locating ring that matches the crimping jaws for a perfect crimp position
- It allows the installer to visually check when the pipe is correctly fitted on the fitting
- The ring is colour coded the same as the protection cap

Auspex Gas crimp fittings are classified as a permanent joint in accordance with AS/NZS 5601. As such, the fittings should not be able to move inside the pipe after crimping has been done.

Pipe and fittings are joined and sealed by the deformation caused by correct crimping of the copper crimp ring. See image cross-section for a connection made between a 32mm fitting and Auspex MLP

1. Multi-Layer Pipe
2. Copper Crimp Ring
3. LF DR Brass Fitting

Auspex Product Design

Approvals and Certifications

The Auspex system has WaterMark certification to AS/NZS 2537, AS 2492 and AS 4176 product standards for use in potable water installations under the installation code AS/NZS 3500. Auspex plumbing systems are approved for hot and cold potable water installations above and below ground. Please consult with local codes for final approval.

The following standards are referred to in the manufacture and installation of the Auspex system.

Reference Standards

- A. AS/NZS 3500 Series - Plumbing and drainage
- B. NCC Vol 3 (PCA) - National Construction Code Volume 3, the Plumbing Code of Australia
- C. ABCB Watermark Scheme Rules
- D. ISO 9001 - Quality Management Systems
- E. AS 4176 - Polyethylene/aluminium and cross-linked polyethylene/aluminium macro-composite pipe systems for pressure applications
- F. AS 2492 - Cross-linked polyethylene (PE-X) pipes for pressure applications
- G. AS/NZS 2537 - Mechanical jointing fittings for use with crosslinked polyethylene (PE-X) for pressure applications
- H. AS/NZS 4020 - Testing of products for use in contact with drinking water
- I. AS 3688 - Water supply and gas systems - Metallic fittings and end connectors
- J. AS 1432 - Copper tubes for plumbing, gas fitting and drainage applications
- K. AS 2345 - Dezincification resistance of copper alloys
- L. NSF/ANSI/CAN 372 - Drinking Water System Components - Lead Content

Above and Beyond

There are around 40 companies approved to manufacture PE-X under the watermark scheme, however, unlike many of those, not only has Auspex been around for over 25 years, Auspex goes above and beyond the minimum requirements in the following ways:

1. Pipe is manufactured in a plant with ISO Type 5 certification – the highest level of third party accreditation, regulated under ISO17067.
2. The system is certified under the ABCB Watermark Scheme.

3. Processes utilised in the design and manufacture of the system are controlled through procedures that are compliant to ISO 9001
4. The PE-X pipe system is PE-X100, rated to 2000kPa, well above the requirements of AS/NZS 3500.

Potable Water Approved AS/NZS 4020

AS/NZS 4020 prescribes tests to analyse the suitability of products for use in contact with drinking water, with regard to their effect on the quality of the water. It is a requirement of Watermark Certification, however, Auspex pipes have been tested in conjunction with common building products beyond the minimum requirements. Please contact your Auspex Rep to discuss.

Environmental Considerations

We recognise that environmental impacts are increasingly important to our stakeholders and to society more broadly. RWC actively manages its consumption of energy, water and raw materials for manufacturing and packaging to mitigate our impact on the environment.

RWC supports local and global efforts to combat climate change and strives for a sustainable low carbon future. Our efforts are aligned with the UNFCCC Paris agreement which is focused on reducing emissions to limit global warming to a 1.5°C increase from pre-industrial levels.

This design update to the Auspex systems has included the following environmental features:

1. Reduction of disposable plastics for sizes 32-63mm by over 50% through the redesign of the protective cap
2. Comprehensive review of packaging
3. Removal of Lead from the manufacturing stream.

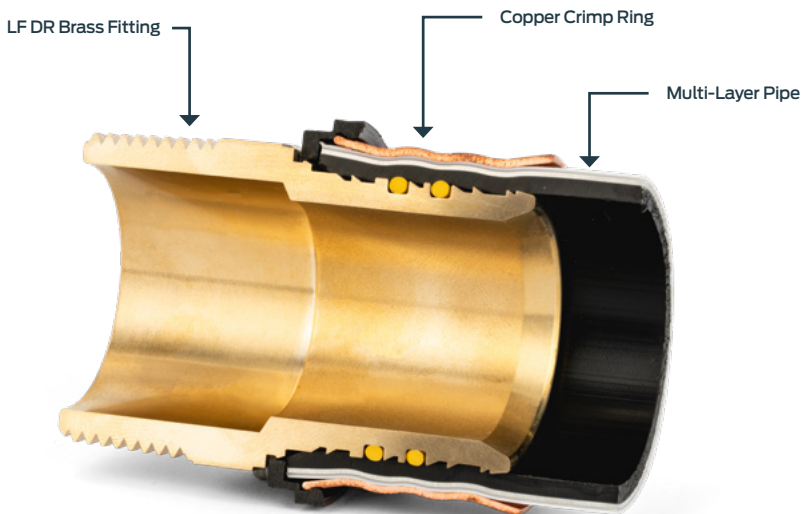

Auspex pipe is intended for use by licensed a plumbing tradesperson, who are experienced in working to accepted plumbing practices.



Auspex PE-X pipe is a cross-linked polyethylene (PE-X) pipe manufactured to comply with AS 2492.

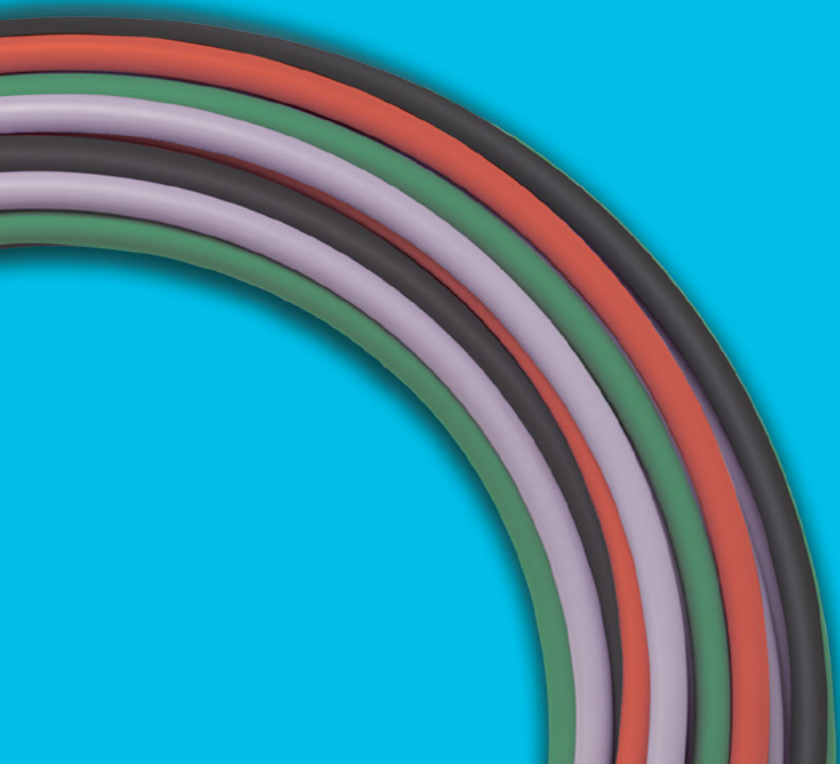

Auspex Pipes

Advantages of the Auspex PE-X Pipe

1. Auspex pipe 16-32mm is made in Melbourne, Australia
2. The lightweight pipe does not have to be expanded or reverted to make the joint
3. Tighter manual bending
4. Corrosion resistant and resistant to scale build up
5. Dampens water hammer noise
6. Auspex pipe is an SDR9 PEX100, giving it the mechanical strength of a more commonly used SDR7.4 PEX80, without a compromise to flow rates
7. Quiet water flow (see acoustic tables in this manual)

Installations should be carried out in accordance with accepted plumbing practices and instructions provided in this manual. However, the installer should also be aware of local authority codes and by-laws relevant to plumbing, which take precedence over these guidelines in any area where they vary.

Installation is subject to the requirements of the applicable regulatory authority, the National Construction Code Volume Three – Plumbing Code of Australia, associated reference standards as applicable at the time and AS/NZS 3500.

General Installation Requirements

Auspex PE-X pipe is manufactured in 16mm and 20mm sizes and supplied in 100m or 50m coils and 5m straight lengths. 25mm pipe is available in 25m coils and 5m straight lengths, and 32mm pipe is available in 5m straight lengths. The pipe is manufactured in accordance with AS 2492, which is far more exacting than other approved plastics materials. Because the pipe is flexible and available in coils you can often use less fittings on a job.

Cross-Linked Polyethylene

Auspex cross-linked polyethylene is extruded as a PE-Xb pipe and manufactured using the silane or 'moisture cure' method and is made in a two-stage simple process.

1. Silane grafted polyethylene is combined with a catalyst and extruded into PE-Xb pipe
2. The cross-linking process is then performed by exposing the pipe to steam

The moisture cure process of cross-linked PE-Xb pipe enhances pipe performance properties including strength, temperature and chemical resistance, crack, creep and abrasion resistance, pipe flexibility, pressure rating, expansion and contraction.

Additionally, Auspex cross-linked polyethylene is made using a PE-X100 raw material, which combined with an SDR9 wall, provides improved flow rates and a pressure rating equivalent to an SDR7.4 pipe made using PE-X80 raw material.

Operating Parameters

Pressure and Temperature

Auspex pipe is manufactured and certified to comply with the performance requirements of AS 2492. Designed to operate with a working pressure of 2000kPa at 20°C and can be operated at 70°C with a maximum working pressure of 1000kPa.

Temperatures above 70°C for any period will affect the life of the pipe.

Designated Auspex connections can only be used on Auspex SDR9 Pipe.

The table below represents the working pressures of cross-linked polyethylene PN20 pipe at various pipe material temperatures (PMT) as per AS 2492.

Temperature	20°C	60°C	70°C
kPa	2000	1190	1000

Water Quality and Chlorine

Potable water is sourced using a variety of methods. The Australian Drinking Water Guidelines provides a framework to govern potable water. To achieve this, chlorine and other agents are sometimes used as constituents of the water. Chlorine levels within the levels of the Australian Drinking Water Guidelines are in most cases suitable in standard discontinuous flow applications. For continuous flow applications such as circulating hot water lines, a maximum chlorine level of 1.2ppm must be maintained.

Water pH levels must be greater than 7.5. Should the installer have concerns relating to water chemistry including chlorine levels for a particular site or application they should contact RWC for further information.

Disinfection of Plumbing System

The Auspex plumbing system is compliant and certified to AS/NZS 2537 and AS 2492 and as such all components of the system have been certified to AS/NZS 4020. RWC can confirm, based on the AS/NZS 4020 certification that the Auspex system does not cause any multiplication of micro-organisms.

RWC recommend that an independently accredited provider is engaged to undertake any thermal disinfection or chemical flush of the system and that this work is carried out in line with the relevant Standards.

Chemical flushes must be limited to a maximum of 5 occurrences over the system lifetime and records must be maintained showing when disinfection took place, what process was followed and who undertook the disinfection works.

Chemical flushing is to be done in line with the Australian Drinking Water Guidelines. The guidelines prohibit flushing potable plumbing systems with a solution greater than 5ppm of chlorine and within the normal operating temperatures and pressures (as specified in the Auspex Technical Literature).

If chemical flushing with a high concentration solution of chlorine is conducted incorrectly it will have a detrimental effect on any piping system. Dosing must be done in such a way as not to exceed the 5ppm chlorine level in any part of the plumbing system.

Thermal disinfection processes must be conducted within the normal operating conditions of the Auspex plumbing system.

Fire and Excessive Heat

- Keep PE-X a minimum of 500mm from sources of high heat such as heating appliances, flues from heating appliances etc
- Keep PE-X 1500mm from slow combustion type stoves and flues used to heat hot water or cooking (wet back type)
- Leave 300mm minimum space between PE-X pipe and light fittings or other electrical fixtures
- PE-X should not be positioned within 150mm of gas or central heating vents or flues
- Where fire collars or the like are required, installers should contact the manufacturer of those products to ensure they have certification for PE-X pipes within the applied application

Uncontrolled Heat Sources

In the case of uncontrolled heat sources (e.g. slow combustion stoves, water heating coils, wet back boilers, solar, or similar) PE-X pipe should not be used. The primary flow and returns on these types of heaters should not be installed in PE-X pipe. Secondary flow and returns must be controlled so that the temperature / pressure requirements are not exceeded.

In the interest of safe temperature and to protect the user, tempering valves should be installed in accordance with AS/NZS 3500.

When using solar systems, installers should consult with manufacturers to ensure that water leaving the storage facilities does not exceed the performance capabilities of the pipe. Primary flow and returns should not be installed in Auspex pipe and secondary flow and returns must be controlled.

Direct Sunlight Exposure

Auspex black pipes manufactured after March 2010 meet the requirements of AS 2492 for carbon black content. As far as the standard is concerned relating to UV stability, the black pipe meets all of the requirements. Confirmation of UV resistance for solid black pipes can be found in

AS/NZS 3500. This **DOES NOT** apply to pipes that have a black co-extruded outer layer.

All Auspex coloured pipes are not to be exposed to direct or reflected UV light and must be protected.

As a conservative company, we still believe that good plumbing practice would see exposed external pipes protected.

Use Under Concrete Slabs

Water pipes located beneath slabs on ground must be laid on a compacted bed of sand or fine-grained soil with a minimum distance of 75mm between the top of the underside of the slab. Pipe work that penetrates the slab must be at right angles to the slab surface and lagged the full length of the slab penetration with an impermeable flexible material not less than 6mm in thickness. Alternatively, an impermeable plastic sleeves or conduit providing equivalent protection.

Any joints located beneath a concrete slab including under any permanent driveway, path, or parking area, should be avoided, however if fittings are required the number used should be kept to a minimum.

Minimum Cold Bending Radii

Ten times the outside diameter of the pipe used.

Diameter	Radii
16mm	160mm
20mm	200mm
25mm	250mm
32mm	320mm

Bending of the pipe for change of direction is preferable to elbows, however fittings will be required where sharp bends are necessary. Tighter bends can be achieved by using a bend support.



Do not use pipes that have kinks, cuts, deep scratches, squashed ends, imperfections or have been in contact with grease or tar substances. Any of the above should be cut out and replaced, as these conditions may affect the integrity of the system.

Avoiding Potential Physical Damage

Before, during, and after installation, pipe and fittings should be protected from any potential physical damage included but not limited to; rodents; radiation; sharp objects; machinery; excessive forces; corrosive agents; and chemicals that may have a detrimental effect on the piping system.

Auspex Burial

Auspex fittings are suitable for burial in most applications, however, care is required when using fittings in such applications as environmental factors may have a detrimental effect on the life expectancy of the fittings and pipe.

The installation of Auspex fittings that require burial or chasing into concrete or brickwork, must comply with all local plumbing code requirements. Auspex fittings are not suitable for use in areas where the soil is or may become contaminated* including the soil used for back filling.

The soil used for back filling must be free of rocks, debris or any sharp objects that may cause damage to the fitting or pipe through impact or abrasion.

Where Auspex fittings are buried in conditions that may be corrosive to brass/copper or otherwise potentially detrimental to the fittings, the fittings must have an impervious barrier between the fitting and the surrounding soil. RWC recommend the use of RWC Silicone Burial Wrap for this purpose.

**Examples of contamination include, but are not limited to: petrochemicals (reclaimed service station sites), high levels of nitrogen compounds (this could be caused by animal waste or fertilizer that may be found in some agricultural applications), low pH levels (below pH 6), high pH levels (above pH 8), run off from land fill, formaldehyde compounds, and solvents. It should be noted that such contaminants have been known to migrate through plastic piping systems and contaminate the potable water supplied through these pipes.*

RWC Silicone Burial Wrap

When using RWC Silicone Burial Wrap, make an Auspex connection as per AS/NZS 3500 (see Installation Instructions in this manual for details). While leaving the protective film in place, measure the amount of tape needed to completely wrap the fitting. To ensure a proper seal, overlap tape by 25mm past the end of the fitting on every end and 5mm – 10mm between/across the fitting.

Completely cover the fitting by wrapping (overlapping each edge of the tape) the fitting, pulling the tape tight and removing the protective film. The tape will bond to itself within minutes and form an impervious barrier within a few hours.



Pipes in Chases, Ducts or Conduits

- Pipes in chases must be continuously wrapped with an impermeable flexible material
- Auspex supply pre-covered 5m lengths suitable for this purpose
- Ducts must be fitted with removable covers
- Conduits embedded in walls or floors should comply with the requirements of the Australian or New Zealand Building Codes as applicable

Although water service pipes are not permitted to be embedded or cast directly into a concrete structure it is permissible for a water service pipe to be within a conduit and then embedded within a wall or floor of masonry or concrete construction.

Refer to AS/NZS 3500.1

Expansion and Contraction

The pipe can handle thermal expansion because of its flexibility. Allowance should be made for thermal expansion and contraction within the pipe work installation, synthetic clips are recommended.

Care should be taken in regard to contraction. Where pipes are installed between fixed points, allow 10mm slack per metre for contraction to overcome undue pressure on the joints if contraction occurs.

The Formula For Calculating Expansion Rates

$$\Delta L = a \times L \times \Delta T$$

ΔL = linear expansion in mm

a = coefficient of linear expansion is 0.15 mm/mK

L = length of pipe in metres

ΔT = temperature difference

The approximate expansion rate of PE-X is 7.5mm per metre in a change of temperature of 50°C.

Thermal Expansion

The tables represent expansion and contraction of PE-X pipe in millimetres, resulting from a given change in temperature.

The tables are calculated using the following equation:

$$\text{Change in pipe length} = 0.1422 \times \text{Pipe length} \times \text{Change in temperature}$$

CHANGE IN TEMPERATURE (°C)

	10	12	14	16	18	20	22	24
1	1.4	1.7	2.0	2.3	2.6	2.8	3.1	3.4
2	2.8	3.4	4.0	4.6	5.1	5.7	6.3	6.8
4	5.7	6.8	8.0	9.1	10.2	11.4	12.5	13.7
6	8.5	10.2	11.9	13.7	15.4	17.1	18.8	20.5
8	11.4	13.7	15.9	18.2	20.5	22.8	25.0	27.3
10	14.2	17.1	19.9	22.8	25.6	28.4	31.3	34.1
12	17.1	20.5	23.9	27.3	30.7	34.1	37.5	41.0
14	19.9	23.9	27.9	31.9	35.8	39.8	43.8	47.8
16	22.8	27.3	31.9	36.4	41.0	45.5	50.1	54.6
18	25.6	30.7	35.8	41.0	46.1	51.2	56.3	61.4
20	28.4	34.1	39.8	45.5	51.2	56.9	62.6	68.3
22	31.3	37.5	43.8	50.1	56.3	62.6	68.8	75.1
24	34.1	41.0	47.8	54.6	61.4	68.3	75.1	81.9
26	37.0	44.4	51.8	59.2	66.5	73.9	81.3	88.7
28	39.8	47.8	55.7	63.7	71.7	79.6	87.6	95.6
30	42.7	51.2	59.7	68.3	76.8	85.3	93.9	102.4
32	45.5	54.6	63.7	72.8	81.9	91.0	100.1	109.2
34	48.3	58.0	67.7	77.4	87.0	96.7	106.4	116.0
36	51.2	61.4	71.7	81.9	92.1	102.4	112.6	122.9
38	54.0	64.8	75.7	86.5	97.3	108.1	118.9	129.7
40	56.9	68.3	79.6	91.0	102.4	113.8	125.1	136.5

LENGTH OF PIPE IN METRES

CHANGE IN TEMPERATURE (°C)

	26	28	30	32	34	36	38	40
1	3.7	4.0	4.3	4.6	4.8	5.1	5.4	5.7
2	7.4	8.0	8.5	9.1	9.7	10.2	10.8	11.4
4	14.8	15.9	17.1	18.2	19.3	20.5	21.6	22.8
6	22.2	23.9	25.6	27.3	29.0	30.7	32.4	34.1
8	29.6	31.9	34.1	36.4	38.7	41.0	43.2	45.5
10	37.0	39.8	42.7	45.5	48.3	51.2	54.0	56.9
12	44.4	47.8	51.2	54.6	58.0	61.4	64.8	68.3
14	51.8	55.7	59.7	63.7	67.7	71.7	75.7	79.6
16	59.2	63.7	68.3	72.8	77.4	81.9	86.5	91.0
18	66.5	71.7	76.8	81.9	87.0	92.1	97.3	102.4
20	73.9	79.6	85.3	91.0	96.7	102.4	108.1	113.8
22	81.3	87.6	93.9	100.1	106.4	112.6	118.9	125.1
24	88.7	95.6	102.4	109.2	116.0	122.9	129.7	136.5
26	96.1	103.5	110.9	118.3	125.7	133.1	140.5	147.9
28	103.5	111.5	119.4	127.4	135.4	143.3	151.3	159.3
30	110.9	119.4	128.0	136.5	145.0	153.6	162.1	170.6
32	118.3	127.4	136.5	145.6	154.7	163.8	172.9	182.0
34	125.7	135.4	145.0	154.7	164.4	174.1	183.7	193.4
36	133.1	143.3	153.6	163.8	174.1	184.3	194.5	204.8
38	140.5	151.3	162.1	172.9	183.7	194.5	205.3	216.1
40	147.9	159.3	170.6	182.0	193.4	204.8	216.1	227.5

LENGTH OF PIPE IN METRES

Clipping

AS/NZS 3500 recommend the following spacings:

Diameter	Horizontal	Vertical
16mm	600mm	1200mm
20mm	700mm	1400mm
25mm	750mm	1500mm
32mm	850mm	1700mm

The above is a guide only. Good plumbing practice requires that clipping be installed so that stress is not imposed on the joint. When bending close to a joint, clips should be placed near the fitting in a manner not to stress the joint.

Timber and Steel Frames

Drill holes through studs, plates etc. large enough so that the Auspex pipe can move freely to allow for expansion and contraction and pressure surges.

Holes drilled or formed in metal studs or plates must be accurately sized to enable suitable grommets. Insulation or a short sleeve of oversize pipe should also be firmly secured in the framework to be inserted around the pipe. This helps to ensure that there is no direct contact between the pipe and framework and allows for movement of the pipe through the grommet, lagging or sleeve.

To avoid noises where pipes pass through studs, plates etc. That have large holes, consideration should be given to the use of a non-aggressive compound, grommet or sleeve in the annular space in the stud or plat.

AS/NZS 3500.1 allows neutral cure silicone to be used around PE-X pipes to fill the annual space drilled through a stud or plate.

Auspex Pipe Colours

Auspex pipe is made in a range of various colours to identify the particular purpose of use and are all manufactured to comply with AS 2492.



Black Pipe

Black Pipe is typically used for Potable Water but can also be used for hot water installations.



Red Pipe

Red Pipe is for hot water applications only.



Purple Pipe

Purple Pipe is coloured and branded specifically for Recycled Water applications.



Green Pipe

Green Pipe is available for rainwater applications.

Precautions

Chemicals

Always check with RWC before using Auspex pipe for applications other than for potable water. Additionally, check with RWC if pipework is to be installed in a known contaminated area, in contaminated soils or where chemical spills may have occurred.

Electrical

It is of the utmost importance that if a metallic pipe is being installed or replaced, by a plastic pipe or other non-metallic fittings or couplings, the requirements of AS/NZS 3500 must be followed.

Additionally, copper tube connected to a Auspex fitting does not guarantee electrical continuity.

No work should be carried out until the earth requirements have been checked by an electrical contractor and modified if necessary.

PE-X Dimensions

The table below references the dimensional requirements for SDR9 PE-X pipe manufactured to AS 2492. Auspex pipe is manufactured to tighter tolerances than required under the standard in order to optimise the Auspex systems performance.

Nominal Size	Tube OD (mm)	Tube Wall (mm)	Tube ID (mm)
DN16	16.0-16.3	2.0-2.3	11.4-12.3
DN20	20.0-20.3	2.3-2.7	14.6-15.7
DN25	25.0-25.3	2.8-3.2	18.6-19.7
DN32	32.0-32.3	3.6-4.1	23.8-25.1

Thermal Conductivity

R-Values of Common Plumbing Piping and Insulation. In certain areas, AS/NZS 3500 requires a minimum insulation of R=0.3. No current piping material will meet this requirement without suitable thermal insulation.

"R-value = Thickness / Conductivity. See AS/NZS 3500.4"

	Conductivity (K)W/M/K	OD (mm)	Wall Thickness (mm)	Nominal ID (mm)	R-Value K.M ² / W
Air	0.02	-	6	-	0.300
Copper DN15	401	12.7	.91	10.88	-0.0000023
Lagged Copper (Approx.)	Cu + Air + Plastic	-	-2	-	0.034
Auspex Pipe 16mm	0.35	16	2.2	11.6	0.006
Auspex Pipe 20mm	0.35	20	2.45	15.1	0.007
Auspex Pipe 25mm	0.35	25	3.2	18.6	0.009
Auspex Pipe 32mm	0.35	32	3.9	24.2	0.011
E-Therm™	0.034	-	8	-	0.235
Requirement of AS/NZS 3500.1 5.19 DN15	0.03	-	9	-	0.300
Requirement of AS/NZS 3500.4 2003 Amendment 1 2005 (Table 8.1 & 8.2)	0.0433	-	13	-	0.300

Pressure or Head Loss Through PE-X Pipe

This graph shows pressure loss through Auspex Pipe at various flow rates in 16mm and 20mm.

In order to calculate the pressure loss through the pipe, the given flow rate for a particular portion of tube must be established (this may be done using the table provided in AS/NZS 3500), along with the required pipe length and diameter. The pressure loss can then be read off the vertical axis.

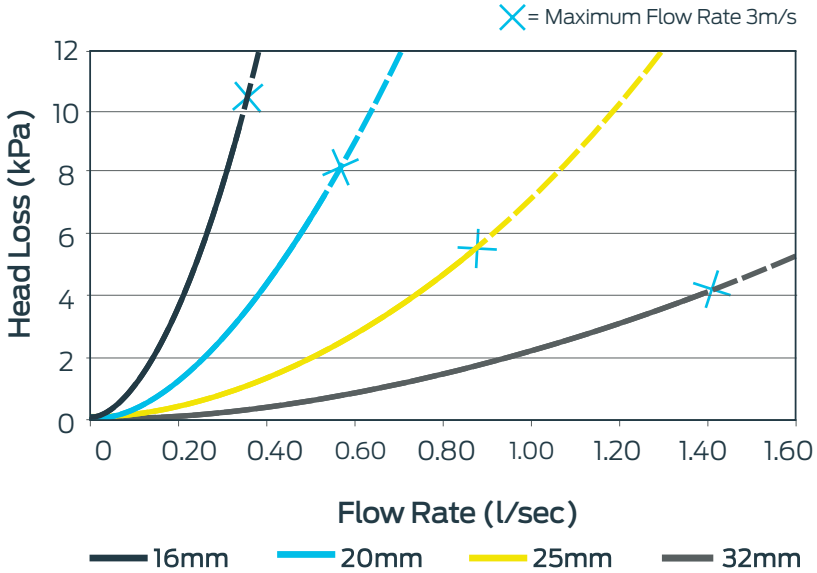

Information provided here is theoretical and based on new clean pipe. No allowance has been made for age or any abnormal conditions of the interior surface of the pipe.

Maximum Flow Rates

Size	16mm	20mm	25mm	32mm
Mean ID (mm)	11.9	15.2	19.2	24.5
Max Flow (L/min)*	20.0	32.0	52.7	84.9
Max Flow (L/sec)*	0.33	0.53	0.88	1.41

Based on AS/NZS 3500 maximum allowable velocity in pipe of 3m/s.

Based on its minimum ID of 15.05mm, 20mm Auspex SDR 9 pipe may be used where AS/NZS 3500 requires a nominal pipe size of DN20. This is a feature of Auspex pipe, and not generally applicable to PE-X pipe.

Pipe Flow Characteristics

Flow Rate (l/min) vs Head Loss (kPa)

	Pipe Size	Flow Rate (l/min)				
		4	20	40	60	80
Head Loss per metre of pipe (kPa)	16mm	0.49	9.54	-	-	-
	20mm	0.15	3.04	-	-	-
	25mm	0.05	0.91	3.27	-	-
	32mm	0.01	0.40	1.02	2.17	3.69

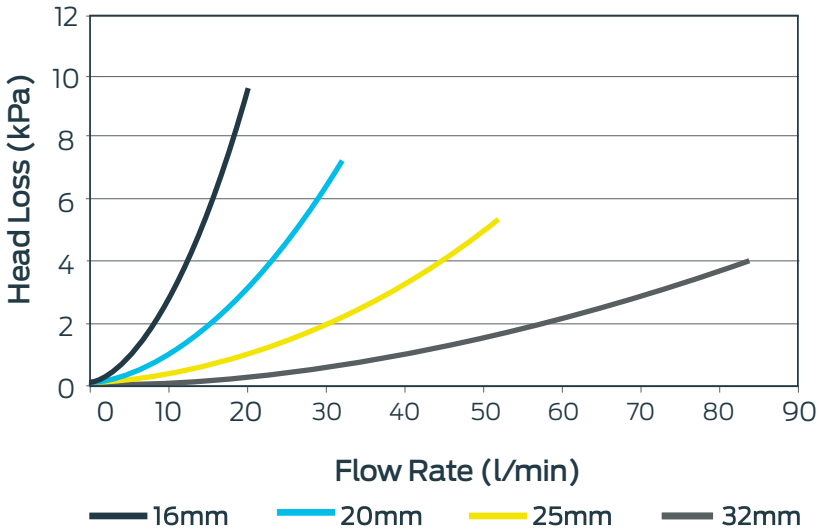

Information provided here is theoretical and based on new clean pipe. No allowance has been made for age or any abnormal conditions of the interior surface of the pipe.

Flow Velocity (m/sec)	Flow Rate (l/min)			
	16mm	20mm	25mm	32mm
1.0m/s	6.7	10.7	17.6	28.3
2.0m/s	13.3	21.3	35.1	56.6
3.0m/s	20.0	32.0	52.7	84.9

Acoustic Tests

Results Summary

- The noise emitted by the pipes through the wall was mainly evident in the mid to high frequencies of the A-weighted spectrum
- Noise emitted at frequencies below 250Hz was affected by the level of background noise in the room
- The change in radiated noise level was greater with the change in water flow compared with the change in water pressure
- In all cases the overall noise level emitted by the Auspex pipe was less than for the copper pipe. For the same flow conditions the differences in overall noise level between the pipes was between 14 and 17dB(A)

Conclusion

Measurements of noise were taken from pipe attached to the other side of a concrete block wall, with water flowing through and a noise source in the pipe.

The measured noise emitted from nominal 15mm bore pipes showed that the Auspex cross-linked polyethylene pipe was between 14 and 17dB(A) quieter than the standard copper pipe.

Water Flow l/min	Water Pressure kPa	Measured Noise Level dB(A)		Difference dB(A)
		Auspex	Copper	Copper – Auspex
15	300	38	55	17
15	600	40	54	14
20	600	45	62	17
20	700	45	62	17

The measured noise level of water flow through nominal 15mm bore Auspex and copper pipe at 20L/min was recorded at both 600kPa and 700kPa using a DIN 52218 noise source.

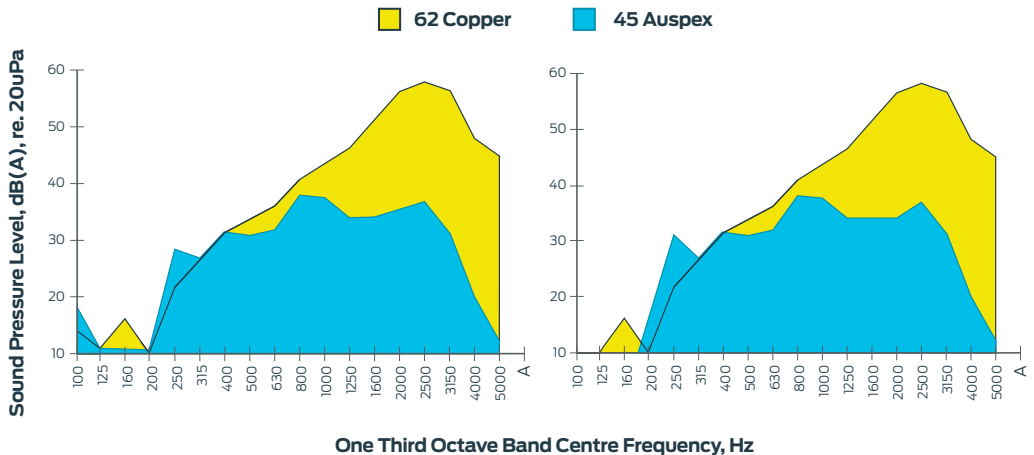

Auspex Stainless Steel Range

Austenitic Stainless Steel

Austenitic stainless steel has been identified as a suitable, cost-effective material for problem environments, primarily in applications where more aggressive water sources are present.

This series is known for its excellent corrosion resistance to a wide variety of chemicals and water sources. Its microstructural characteristics also provide a unique combination of strength and toughness for the material's service life.

Reverse Osmosis (RO Water)

Reverse osmosis (RO) is a water purification process that removes all the contaminants including minerals from the drinking water supply.

The Auspex Stainless Steel range of fittings is suitable for RO water applications however the DZR brass range of fittings must not be used for such applications.

All relevant system guidelines as presented in the Auspex Technical Manual apply to the use of Stainless Steel fittings for RO applications.



Alloy Designation

British Standard EN10088-1 (2005): [X5CrNiMo17-12-2] – alloy code 1.4401

Alloy Equivalents in ASTM cast series and AISI/UNS wrought series:

- ASTM – [CF-8M]
- AISI – [Type 316]
- UNS – [C31600]

Chemical Composition (Cast Analysis)

C	Si	Mn	P max	S	N
0.07	1.00	2.00	2.00	0.015	0.11
Cr	Cu	Mo	Nb	Ni	Fe
16.50 to 18.50	–	2.00 to 2.50	–	10.00 to 13.00	REM

The British standard alloy designation 1.4401 [X5CrNiMo17-12-2] is used to describe the specific chemical composition chosen for this series of Auspex fittings.

This type of alloy is classified as a corrosion resistant cast steel that has a good resistance to both uniform and local attack which is provided by the Chromium (Cr) content in the alloy. The Cr spontaneously forms a protective oxide film which acts as a barrier to corrosion and is the base protective mechanism of stainless steel.

In addition to this, Molybdenum (Mo) is also included in the composition for increased resistance to crevice corrosion and pitting in chloride-containing environments (as found in many aggressive water sources).

These fittings will consist of ~5-20% Ferrite distributed in discontinuous pools throughout an Austenite matrix which provides a unique combination of properties appropriate for use in various potable water applications.

The Austenite phase (FCC crystal structure) possesses excellent ductility, formability and has a high fracture toughness. The presence of Ferrite (BCC crystal structure) in the alloy is beneficial for resistance to stress corrosion cracking (SCC) and intergranular attack.

In the case of SCC, the Ferrite blocks crack propagation through the Austenite matrix. It also promotes resistance to intergranular cracking by preferentially precipitating carbides along its grain boundaries, rather than along the Austenite grain boundaries, where they would increase susceptibility to intergranular attack.

The presence of Ferrite is also beneficial to the tensile and yield strength of the alloy without any significant reduction in toughness. As the ~5-20% Ferrite is magnetic (Austenite is not), there will be a low magnetic response from this alloy.

Installation Instructions

Auspex fittings from 16–25mm use a copper crimp ring connection and can be crimped with an Auspex manual tool or a Rothenberger battery tool. It is most important that the tool manual supplied with the tool is read in its entirety and the user becomes familiar with the maintenance, calibration and proper use of the tool.

Step 1.

Measure the pipe to the correct length and using a secateur-type pipe cutter, cut the pipe squarely and remove any burrs. The end of the pipe may need to be freshly cut to ensure smooth passage for the fitting.

Do not use a hacksaw.



Step 2.

The pipe is pushed over the barbed fitting and at the same time under the crimp ring. The fit should be firm. If the joint feels sloppy or hard to insert, check pipe and fittings. Do not use lubricants. Ensure the pipe is visible in both crimp ring witness holes.

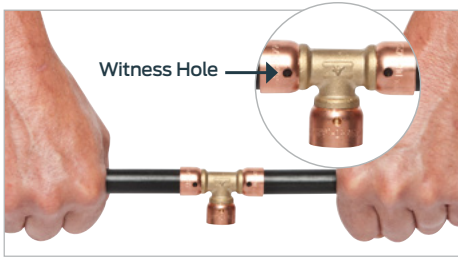

Step 3.

Make sure the tool jaws are centralised over the crimp ring at 90° to the joint.

When using the manual tool, close the tool completely to compress the crimp ring. The tool will click at final compression.

When using a battery tool, ensure the tool has fully closed and released indicating a completed joint.

Step 4.

For manual tool use, regularly check with the gauge supplied by sliding the opening of the gauge over the compressed ring.



If the gauge passes over all parts of the ring without interference, then the joint has been crimped satisfactorily.

Correctly serviced battery tools do not require a gauge check if the joint has been completed as per instructions.

Step 5.

Pressure test the system in accordance with AS/NZS 3500 and with local requirements.

If the gauge experiences any interference, the joint is under crimped. The tool should then be adjusted. (See adjustment instructions in this manual). Do not double crimp. Design the installation in such a way as to not stress the system joints, bend supports may be required.



32mm Joints

When crimping Auspex 32mm, use the battery tool with a 32mm Auspex Jaw. Place the fitting inside the jaws so that the raised section of the plastic sight ring fits into the slot in the jaws. Release the jaws so they fit perfectly over the fitting, ensuring that the raised section of the plastic sight ring is still located in the slots in the jaw.

Press the switch mechanism until the joint is completed. Press the back end of the jaws and remove the completed joint.



General Installation Tips

The Gauge

The gauge is one of the quality controls of the system. It verifies firstly that the ring has been crimped and secondly, that it has been compressed enough.

Gauging of the compressed ring should be done regularly throughout each job.

When using the gauge, slide the opening over the compressed ring. If the gauge passes over all parts of the ring without interference then the joint has been done satisfactorily. Do not place the gauge over the pipe and then move it back along the pipe and over the ring. This may not give a true reading. If the gauge is lost, it should be replaced immediately.

If the gauge experiences any interference the joint is under crimped. The tool should then be adjusted. **DO NOT DOUBLE CRIMP.**

Plastic Holding Ring

While most fittings within the Auspex range utilise the captive copper crimp ring technology, there are some applications where a removable crimp ring is advantageous. For these products a plastic retainer ring is used to hold the crimp ring to the fitting. It plays no part in the integrity of the joint. It may behave differently after crimping, however as a general rule, the back of this ring should be flush against the body of the fitting and the crimp ring should be attached to it. This starting position will also help to ensure full penetration of the fitting inside the pipe.

For Mark II fittings (16-25mm) where the crimp ring is held in place without the plastic ring, the tool jaws must be aligned to the end of the crimp ring where the pipe enters the fitting.

The Pipe

Pipe coming out of the crimped ring at an angle may indicate that the pipe is not covering all of the barbs on one side. This situation may occur if a tight bend is made close to a joint or if the pipe has moved in some way prior to crimping. Where possible, crimp the fitting before making the tight bend and install a clip close to the joint between the bend and the joint. Use a bend stabiliser to avoid stress on the joint.

Coloured Plastic Rings

The Auspex crimp system has a range of adaptors, which are identified by a different coloured plastic ring. Do not join Auspex pipe by using a fitting with a coloured ring. To identify the uses for these adaptors, consult your supplier or Auspex directly.

Pinched Ring

When crimping fittings which are flush to frames etc, check to ensure that the crimp ring has not pinched on the back side. Rings which are pinched in this manner should be replaced.

Clips

The clips should be installed so that the pipe can move freely through the clip. Plastic clips are recommended.

Tooling

Only Auspex approved tooling can be used with the Auspex system. Manual hand crimpers are available for 16mm, 20mm, and 25mm. Auspex and Rothenberger battery tools with approved jaw sets are also available, 16-32mm.

Troubleshooting

The Auspex crimp system is simple and effective when executed in accordance with the jointing procedures in this manual. However, if sufficient care is not taken, this can result in an ineffective joint.

Ineffective joints may occur if:

- The crimping tool has not been completely closed
- The crimping tool is out of adjustment. Re-adjust tool in accordance with the instructions supplied with the tool, and in this manual
- The copper ring has moved away from the fitting body
- The crimping tool has not been centred over the copper ring and the jaw has overhung the end of the fitting
- The crimping tool has not been at 90° to the joint being made
- The pipe has been cut badly out of square
- The witness hole is not completely filled (the fitting is not fully inserted in the pipe)
- The fitting has been double crimped

Examples of ineffective joints:

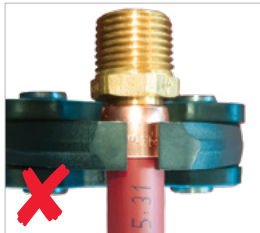

Jaw not centred on the crimp ring



Witness hole not completely filled

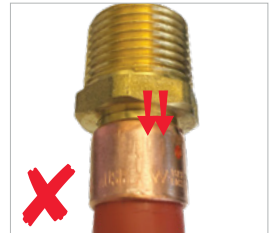

Fitting has been double crimped



Jaw not square on the crimp ring



Pipe badly cut and not square to fitting



Fitting has been under crimped

If an ineffective joint is detected:

- Cut out the defective joint and replace with new fitting

Non-compliant fittings that are removed cannot be re-used.





Multi-Layer Pipe

Introducing a new range of Multi-Layer (MLP) pipes suitable for water, gas, heating, domestic sprinkler and HVAC installations in sizes 16, 20, 25, 32, 40, 50 and 63mm, Auspex now offers the wider plumbing industry varying solutions for the transportation of water and gas.

The modernisation of the Auspex system includes a HNBR O-ring compound suitable for both water and gas applications providing plumbers a 'One fitting' solution. The traditional Auspex copper crimp ring design across the entire range of fittings in sizes from 16-63mm provides uniformity in appearance and a truly complete system.

With the Auspex systems rationalisation and modernisation the DuoPEX Gas and Water systems will be progressively retired. For those loyal DuoPEX users, the new Auspex system has had you front of mind. By adopting the same DuoPEX crimp profile for the new Auspex system all current DuoPEX battery tools and crimping heads for sizes 32, 40, 50 and 63mm are compatible for use with Auspex. Transition to Auspex from DuoPEX is therefore easy!

Today and tomorrow's generation of plumber will continue to lead the industry with the new Auspex system as the Tradition of Trust continues.

Multi-Layer Water Pipe

Auspex now includes a white multi-layer or composite system, designed to be used in potable hot and cold water systems and can also be used for heating purposes.

Auspex Water Multi-Layer Pipe (MLP) consists of:

1. An inner layer of cross-linked polyethylene (PE-X)
2. An aluminium layer
3. An outer layer of polyethylene - raised temperature (PE-RT)
4. Inner and outer adhesive layers

The pipe is manufactured using the latest butt-welding technique. This technique ensures there are no compromises to polymer thickness to cater for an overlap weld.

Auspex Water MLP is available in all sizes from 16mm to 63mm with a white outer layer and black inner layer.

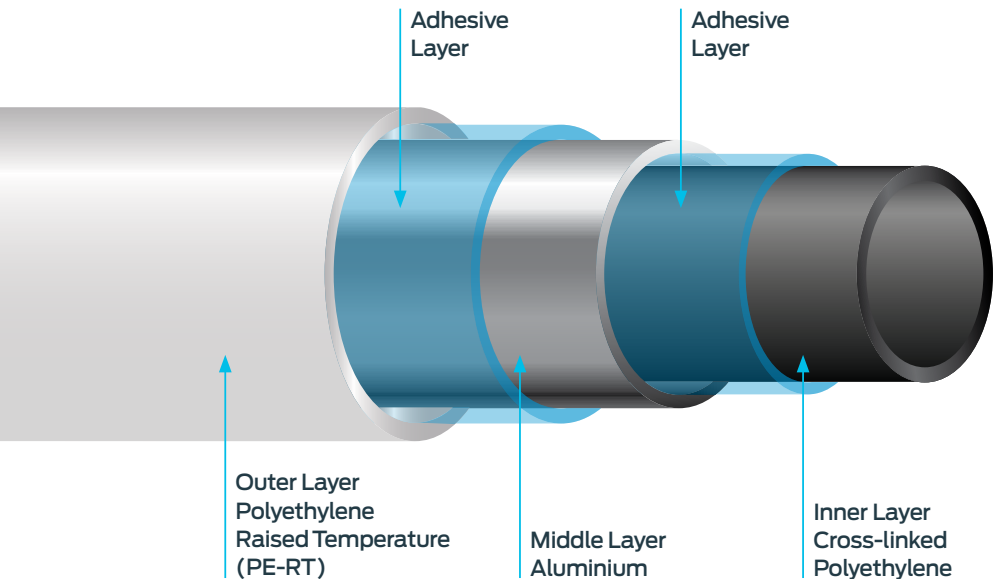

All white Multi-Layer Water Pipes carry a Watermark Licence and sizes 16mm - 32mm can additionally be supplied in pre-insulated coils.



Do not use pipes that have kinks, cuts, deep scratches, squashed ends, imperfections or have been in contact with contaminating substances. Such pipe should be cut out and replaced, as these conditions may affect the integrity of the system.

Forming Stability

After bending, the Auspex Multi-Layer Pipe will remain stable due to the aluminium layer. In many cases, thanks to this characteristic, it is possible to prefabricate assemblies before delivery to the site.

Minimum Bending Radii

Bending can be made manually, however if tighter bends are required, bending tools may be used.

Nominal diameter (d _a x s)	Bending radius (R) without aid	Bending radius (R) with bending spring	Bending radius (R) with bending tool
16 x 2.2	5 x d _a - 80	3 x d _a - 48	55
20 x 2.5	5 x d _a - 100	3 x d _a - 60	79
25 x 3.0			88
32 x 3.9			128
40 x 3.5			4.0 x d _a - 160
50 x 4.0			4.0 x d _a - 200
63 x 4.5			4.0 x d _a - 252

Note: All measurements in mm unless otherwise stated.

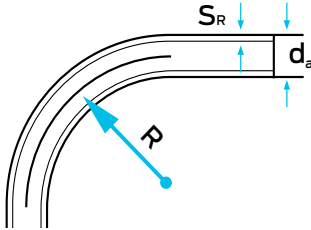

The bending process on Auspex Multi-Layer Pipe must not result in either indentations or deformations on the inside of the pipe bend. Damage to the PE-X layer of the Auspex Multi-Layer Pipe may affect the integrity of the system.

Fastening Spacing

DN	Pipe dimension	Maximum spacing of fasteners (S)		Pipe weight with water (kg/m)
		Horizontal	Vertical	
12	16 x 2.2	1200	1500	0.225
15	20 x 2.5	1350	1500	0.355
20	25 x 3.0	1500	1750	0.608
25	32 x 3.9	1650	2000	0.935
32	40 x 3.5	2000	2000	1.438
40	50 x 4.0	2500	2500	2.264
54	63 x 4.5	2500	2500	3.611

Note: All measurements in mm unless otherwise stated.

Thermal Changes in Length

Heating and cooling cause pipe length changes. The coefficient of expansion of Auspex Multi-Layer Pipes is 0.026 mm/m x k. For further information on linear expansion tables and expansion bend examples contact your Auspex representative.

Example Temperature

Differential ΔT	50 k
Pipe length L	5 m
Coefficient of expansion a	0.026 mm/m.K
Linear expansion ΔL	6.5 mm
ΔL	= a x L x ΔT = 0.026mm/m.K x 5 m x 50 K = 6.5 mm

Thermal conductivity = 0.45 W/M x K

Installation Considerations

- Keep Auspex Multi-Layer Pipe a minimum of 500mm from sources of high heat, such as heating appliances and flues from heating appliances
- Keep Auspex MLP 150mm from slow combustion type stoves and flues used to heat hot water or cooking (wet back type)
- Leave 300mm minimum space between Auspex Water pipe and light fittings or other electrical fixtures
- Auspex MLP should not be positioned within 150mm of gas or central heating vents or flues
- Where fire collars or the like are required, installers should contact the manufacturer of those products to ensure they have certification for MLP construction

Uncontrolled Heat Sources

In the case of uncontrolled heat sources (e.g. slow combustion stoves, water heating coils, wet back boilers, solar, or similar) Auspex Water pipe should not be used. The primary flow and return on these types of heaters should not be installed in Auspex Water pipe. Secondary flow and returns must be controlled so that the temperature/pressure requirements are not exceeded.

In the interest of safe temperatures and to protect the user, tempering valves should be installed in accordance with AS/NZS 3500.

When using solar systems, installers should consult with manufacturers to ensure that water leaving the storage facilities does not exceed the performance capabilities of the pipe. Primary flow and returns should not be installed in Auspex Water pipe and secondary flow and returns must be controlled.

Temperature/Pressure Requirements

AS 4176 allows PE-X/AL/PE-X pipes to be used at 1000kPa at a temperature of 70°C. For applications in excess of 1000kPa, please consult with your Auspex representative.

Direct Sunlight Exposure

The Auspex Water pipe **should not** be used in direct sunlight. Lay flat sleeving is available for sizes 32mm to 63mm, however this sleeving has a maximum UV life of 4 years and should be replaced prior to that time. Lay Flat sleeving is available in lilac and green for recycled

and rainwater applications, but they do not offer any UV protection. It is best practice to sleeve exposed pipes. 16mm to 26mm pipe is not suitable for exposure to direct sunlight.

Temperature Correction Factor

Temperature	Flow Velocity [V (m/s)]						
	0.5	1.0	2.0	3.0	4.0	5.0	6.0
10°C	1.0	1.0	1.0	1.0	1.0	1.0	1.0
20°C	0.93	0.94	0.94	0.95	0.95	0.96	0.96
30°C	0.88	0.89	0.90	0.91	0.92	0.93	0.93
40°C	0.83	0.84	0.86	0.88	0.89	0.90	0.91
50°C	0.79	0.81	0.84	0.86	0.87	0.88	0.89
60°C	0.76	0.78	0.81	0.83	0.85	0.86	0.87
70°C	0.73	0.76	0.79	0.81	0.83	0.84	0.86
80°C	0.71	0.73	0.77	0.80	0.82	0.83	0.84
90°C	0.68	0.71	0.75	0.78	0.80	0.82	0.83

Chemical Resistance

The chemical properties of polyethylene are significantly improved by the cross-linking process.

Auspex Water pipes are resistant to the following media:

- Concrete, plaster, mortar, and cement
- Disinfectants and cleaning agents according to DVGW worksheet W 291 and DIN 2000
- All natural potable water constituents
- Corrosion – protection agents according to DIN 1988 Part 4

Auspex Water pipes must be protected against:

- Direct contact with bitumen or bitumen strips
- Greases, solvents and oils
- Contaminated areas as defined in AS/NZS 3500

If the Auspex MLP Water system is used in areas where, for example, aggressive gases, permanently acting moisture or building materials containing chlorine are to be encountered, the pipe and fittings must be protected using suitable jacketing. It is also best practice to protect fittings with suitable jacketing when in contact with screed, concrete, mortar or plaster. Always consult the manufacturer for details.

Timber & Steel Frames

Drill holes through studs, plates etc. large enough so that the Auspex pipe can move freely to allow for expansion and contraction and pressure surges.

Holes drilled or formed in metal studs or plates must be accurately sized to enable suitable grommets. Insulation or a short sleeve of oversize pipe should also be firmly secured in the framework to be inserted around the pipe. This helps to ensure that there is no direct contact between the pipe and framework and allows for movement of the pipe through the grommet, lagging or sleeve. To avoid noises where pipes pass through studs, plates etc. That have large holes, consideration should be given to the use of a non-aggressive compound, grommet or sleeve in the annular space in the stud or plate. AS/NZS 3500 allows neutral cure silicone to be used around polyolefin pipes to fill the annual space drilled through a stud or plate.

Use Under Concrete Slabs

Water pipes located beneath slabs on ground must be laid on a compacted bed of sand or fine-grained soil with a minimum distance of 75mm between the top of the underside of the slab. Pipe work that penetrates the slab must be at right angles to the slab surface and lagged the full length of the slab penetration with an impermeable flexible material not less than 6mm in thickness. Alternatively, an impermeable plastic sleeves or conduit providing equivalent protection.

Any joints located beneath a concrete slab including under any permanent driveway, path, or parking area, should be avoided, however if fittings are required the number used should be kept to a minimum.

Auspex Burial

Auspex fittings are suitable for burial in most applications, however, care is required when using fittings in such applications as environmental factors may have a detrimental effect on the life expectancy of the fittings and pipe. The installation of Auspex fittings that require burial or chasing into concrete or brickwork, must comply with all local plumbing code requirements. Auspex fittings are not suitable for use in areas where the soil is or may become contaminated* including the soil used for back filling.

The soil used for back filling must be free of rocks, debris or any sharp objects that may cause damage to the fitting or pipe through impact or abrasion.

Where Auspex fittings are buried in conditions that may be corrosive to brass/copper or otherwise potentially detrimental to the fittings, the fittings must have an impervious barrier between the fitting and the surrounding soil. RWC recommend the use of RWC Silicone Burial Wrap for this purpose.

**Examples of contamination include, but are not limited to: petrochemicals (reclaimed service station sites), high levels of nitrogen compounds (this could be caused by animal waste or fertilizer that may be found in some agricultural applications), low pH levels (below pH 6), high pH levels (above pH 8), run off from land fill, formaldehyde compounds, and solvents. It should be noted that such contaminants have been known to migrate through plastic piping systems and contaminate the potable water supplied through these pipes*

RWC Silicone Burial Wrap

When using RWC Silicone Burial Wrap, make an Auspex connection as per AS/NZS 3500 (see Installation Instructions in this manual for details). While leaving the protective film in place, measure the amount of tape needed to completely wrap the fitting. To ensure a proper seal, overlap tape by 25mm past the end of the fitting on every end and 5mm – 10mm between/across the fitting.

Completely cover the fitting by wrapping (overlapping each edge of the tape) the fitting, pulling the tape tight and removing the protective film. The tape will bond to itself within minutes and form an impervious barrier within a few hours.



Pipes in Chases, Ducts or Conduits

Pipes in chases must be continuously wrapped with an impermeable flexible material. Auspex supply pre-covered 5m lengths suitable for this purpose. Ducts must be fitted with removable covers. Conduits embedded in walls or floors should comply with the requirements of the Australian or New Zealand Building Codes as applicable.

Although water service pipes are not permitted to be embedded or cast directly into a concrete structure it is permissible for a water service pipe to be within a conduit and then embedded within a wall or floor of masonry or concrete construction.

Avoiding Potential Physical Damage

Before, during, and after installation, pipe and fittings should be protected from any potential physical damage included but not limited to; rodents; radiation; sharp objects; machinery; excessive forces; corrosive agents; and chemicals that may have a detrimental effect on the piping system.

Water Quality and Chlorine

Potable water is sourced using a variety of methods. The Australian Drinking Water Guidelines provides a framework to govern potable water. To achieve this, chlorine and other agents are sometimes used as constituents of the water. Chlorine levels within the levels of the Australian Drinking Water Guidelines are in most cases suitable in standard discontinuous flow applications. For continuous flow applications such as circulating hot water lines, a maximum chlorine level of 1.2ppm must be maintained.

Water pH levels must be greater than 7.5. Should the installer have concerns relating to water chemistry including chlorine levels for a particular site or application they should contact RWC for further information.

Disinfection of Plumbing System

The Auspex plumbing system is compliant and certified to AS 4176 and as such all components of the system have been certified to AS/NZS 4020. RWC can confirm, based on the AS/NZS 4020 certification that the Auspex system does not cause any multiplication of micro-organisms, microbial contamination.

RWC recommend that an independently accredited provider is engaged to undertake any thermal disinfection or chemical flush of the system and that this work is carried out in line with the relevant Standards.

Chemical flushes must be limited to a maximum of 5 occurrences over the system lifetime and records must be maintained showing when disinfection took place, what process was followed and who undertook the disinfection works. Chemical flushing is to be done in line with the Australian Drinking Water Guidelines. The guidelines prohibit flushing potable plumbing systems with a solution greater than 5ppm of chlorine and within the normal operating temperatures and pressures (as specified in the Auspex Technical Literature).

If chemical flushing with a high concentration solution of chlorine is conducted incorrectly it will have a detrimental effect on any piping system. Dosing must be done in such a way as not to exceed the 5ppm chlorine level in any part of the plumbing system.

Thermal disinfection processes must be conducted within the normal operating conditions of the Auspex plumbing system.

Water Pressure Loss

Calculation of Potable Water – Principals

The following tables show Pressure Loss for Auspex Water pipe at a fluid temperature of 10°C.

Pipe Size	16mm		20mm		25mm	
Flow Velocity V (m/s)	Volumetric Flow V (L/s)	Pressure Loss R (mbar/m)	Volumetric Flow V (L/s)	Pressure Loss R (mbar/m)	Volumetric Flow V (L/s)	Pressure Loss R (mbar/m)
0.5	0.06	0.35	0.09	0.26	0.15	0.20
0.6	0.07	0.49	0.11	0.37	0.18	0.28
0.7	0.08	0.65	0.13	0.50	0.20	0.36
0.8	0.09	0.83	0.14	0.63	0.23	0.47
0.9	0.10	1.03	0.16	0.78	0.26	0.59
1.0	0.11	1.26	0.18	0.96	0.29	0.72
1.2	0.13	1.75	0.21	1.34	0.35	1.00
1.4	0.16	2.34	0.25	1.78	0.41	1.33
1.6	0.18	3.00	0.29	2.28	0.47	1.71
1.8	0.20	3.71	0.32	2.83	0.53	2.12
2.0	0.22	4.52	0.36	3.43	0.59	2.58
2.5	0.28	6.85	0.44	5.20	0.73	3.90
3.0	0.33	9.57	0.53	7.29	0.88	5.45
3.5	0.39	12.74	0.62	9.73	1.00	7.28
4.0	0.45	16.33	0.71	12.43	1.17	9.31
4.5	0.50	20.27	0.80	15.44	1.32	11.58
5.0	0.56	24.66	0.89	18.81	1.46	14.08

Pipe Size	32mm		40mm	
Flow Velocity V (m/s)	Volumetric Flow V (L/s)	Pressure Loss R (mbar/m)	Volumetric Flow V (L/s)	Pressure Loss R (mbar/m)
0.5	0.24	0.15	0.43	1.09
0.6	0.28	0.21	0.51	1.51
0.7	0.33	0.28	0.6	1.95
0.8	0.38	0.36	0.68	2.50
0.9	0.43	0.45	0.77	3.07
1.0	0.47	0.55	0.88	3.71
1.2	0.57	0.76	1.03	5.17
1.4	0.66	1.01	1.2	6.83
1.6	0.76	1.30	1.37	8.57
1.8	0.85	1.61	1.54	10.7
2.0	0.95	1.96	1.71	13.03
2.5	1.18	2.96	2.14	19.69
3.0	1.41	4.14	2.57	27.54
3.5	1.65	5.51	2.99	36.37
4.0	1.89	7.06	3.42	46.05
4.5	2.12	8.79	3.85	57.67
5.0	2.36	10.68	4.28	69.68

Pipe Size	50mm		63mm	
Flow Velocity V (m/s)	Volumetric Flow V (L/s)	Pressure Loss R (mbar/m)	Volumetric Flow V (L/s)	Pressure Loss R (mbar/m)
0.5	0.69	0.80	1.15	0.59
0.6	0.83	1.11	1.37	0.81
0.7	0.97	1.46	1.60	1.08
0.8	1.11	1.86	1.83	1.37
0.9	1.25	2.30	2.06	1.66
1.0	1.39	2.80	2.29	2.04
1.2	1.66	3.82	2.75	2.83
1.4	1.94	5.09	3.21	3.76
1.6	2.22	6.52	3.66	4.86
1.8	2.49	8.10	4.12	5.91
2.0	2.77	9.90	4.58	7.15
2.5	3.46	14.8	5.73	10.7
3.0	4.16	20.46	6.87	14.91
3.5	4.85	27.27	8.02	19.85
4.0	5.54	35.04	9.16	25.48
4.5	6.23	43.14	10.31	31.49
5.0	6.93	52.67	11.45	38.19

Water Pressure Loss Diagram

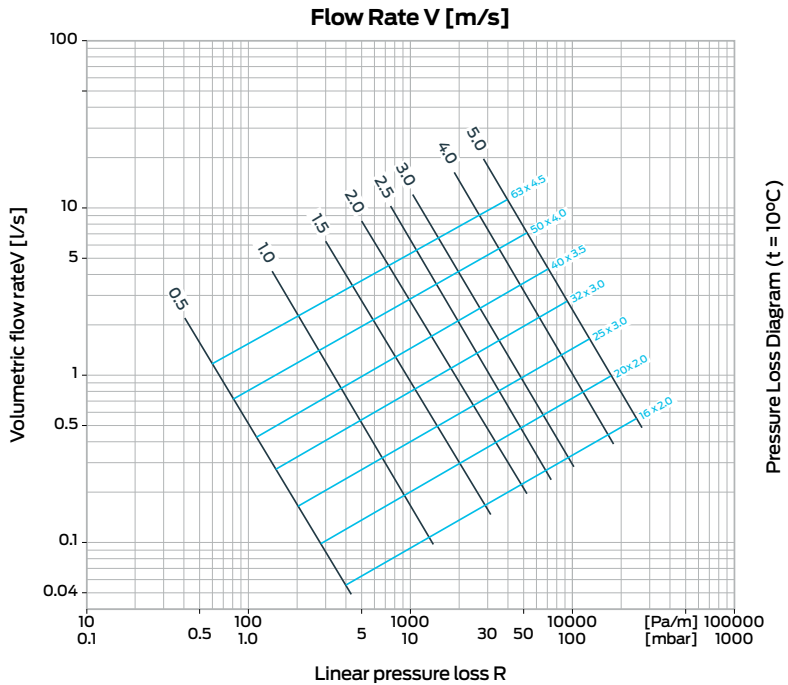







Auspex Water Fitting Pressure Drop

Pressure losses due to individual resistances can be calculated based on the loss coefficients and based on the equivalent pipe lengths of the individual resistances.

These value equivalents are then added to the pipe lengths of the respective pipe sections to then calculate the total resistance.

Pressure Losses Due to Individual Resistances of Auspex Water Fittings

Individual Resistance (a)	Graphic Symbol (b)	Equivalent Pipe Length Pipe Diameter						
		16	20	25	32	40	50	63
Tee, Branch Flow Separation		3.13	4.26	2.8	3.0	3.4	4.5	2.3
Tee, Transition Flow Separation		0.97	0.41	0.55	0.6	1.4	0.8	0.9
Tee, Transition Flow Separation		10.1	5.1	3.8	3.2	3.4	4.2	2.3
Angle / 90° Elbow		3.8	3.8	2.6	3.0	3.5	3.9	2.0
Angle / 45° Elbow		–	–	3.2	2.0	1.9	1.6	0.6
Reduction		--	14.0 (32mm) 4.6 (25mm)	2.8	--	3.1	3.2	2.5
Coupling		0.94	0.38	0.55	0.5	1.0	0.5	0.3

- a. The symbol "V" for flow velocity defines the location of the proper reference velocity in the fitting and connecting piece
- b. For reduced tees, the resistance value of the similar tee is assumed with the smallest dimension of the reduced tee for the flow path to be calculated

General: The loss coefficient is assigned in each case to the volumetric flow (partial flow), which is indicated in the diagram with the symbol "V".

A flow rate of 2m/s was assumed to calculate the equivalent pipe lengths.

Making A Joint

It is most important that the tool manual supplied with the tool is read in its entirety and the user becomes familiar with the maintenance, precautions and the proper use of this tool.

The following describes, in general terms, the jointing procedures but should not be regarded as a substitute for reading and applying the detailed instructions contained in the tool manual.

1. Ensure that the battery is fully charged and attach it to the tool.
2. Select the jaw size to suit the fitting to be crimped. The jaws must be examined in terms of possible damage, or dirt in the compression area.
3. To change the jaw, push the pin in and turn pin to unlock.
4. Insert the jaws and line up the holes in the tool with the hole in the jaw.
5. Push the pin through the hole in the jaw and turn pin to lock.
6. Cut the pipe to the required length with the recommended multi-layer pipe cutters.



7. Insert the approved calibrating/deburring tool into the pipe, and then alternately turn in a clockwise and in a counter-clockwise direction. Ensure that a consistent, smooth chamfer is formed on the end of the pipe



8. Insert the pipe into the fitting and under the copper ring and push the pipe until it is visible in the slots of the witness hole. This ensures you have pushed the pipe home.

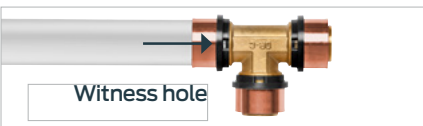

9. By squeezing the back of the jaw, the jaws will open. If you look at the machined profile on the inside of the jaws you will note a slot on each side of the profile.



10. With the jaws open place the fitting inside the jaws so that the raised section of the plastic sight ring fits into the slot in the jaws. Release the jaws so they fit snugly over the fitting, ensuring that the raised section of the plastic sight ring is still located in the slots in the jaw.



11. Press the switch mechanism until the joint is completed and the piston has retracted back into the body of the tool.



12. Press the back end of the jaws and remove the completed joint..



Multi- Layer Gas Pipe

The Auspex Gas System is a multi-layer pipe made from Cross Linked Polyethylene (PE-X) on both the outer and inner layers and aluminium in between. Having PE-X on both layers ensures that the highest performing polymer is on both sides of the aluminium core. Auspex Gas has a defining black inner layer and can easily be identified.

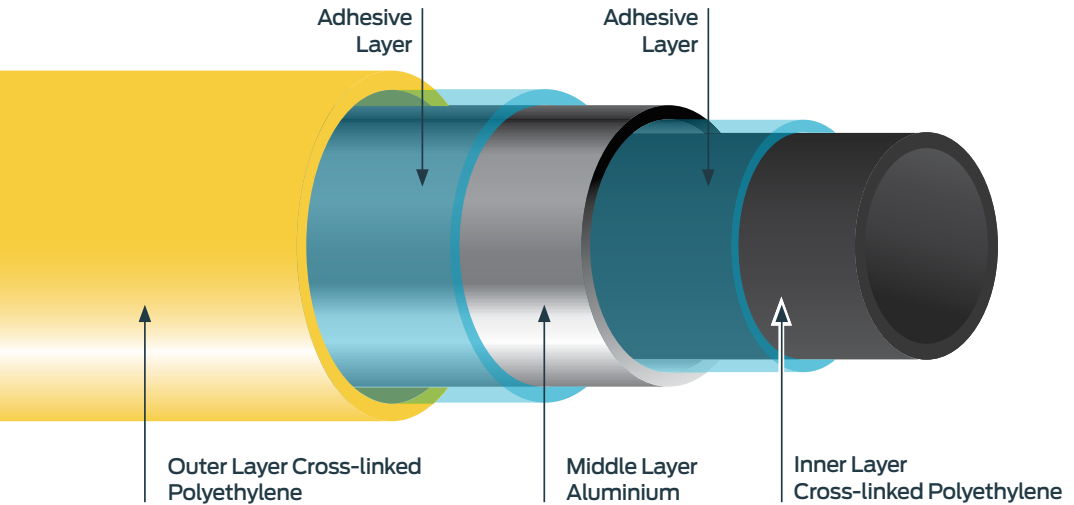

The pipe is manufactured using the latest butt-welding technique. This technique ensures there are no compromises to polymer thickness to cater for an overlap weld.

The wall thickness of the 16 - 32mm multi-layer pipes have been specifically engineered to match the SDR 9 Auspex single layer water pipes. This allows most Auspex water fittings to be compatible with the Auspex Gas pipes. Auspex fittings have copper crimp rings in sizes 16-63mm.

The assembled system has been tested to AS/NZS 5601 and proven to comply with the Rothenberger tool using the range of Auspex jaws (16-63mm) and alternatively with a manual crimping tool (16-25mm). A gauge is provided to verify the correct crimp compression.

All installations should be carried out in accordance with AS/NZS 5601, and instructions provided in this chapter of the technical manual. The installer must be a licenced gas fitter and proof of training by an approved Auspex Gas representative should be always carried. The installer should also be aware of local authority codes and by laws which take precedence. If clarification is required, contact your local Auspex representative or the Customer Service number shown in this manual.

Advantages of an Auspex Gas System

1. Form stability during installation, for an example in a curve
2. Low thermal conductivity level
3. Light weight during transportation and installation
4. Thermal expansion is lower than that of other pipe
5. Lower pressure loss thanks to the smooth inner layer
6. Impermeability to gases in general



Auspex Gas pipe has been tested and certified in accordance with AS 4176.

Bending of Auspex Gas Pipe

Auspex Gas pipe is supported by the aluminium layer and will remain stable after bending. Bending can be done manually, however, bending tools are available if required. Care must be taken during this process to ensure that the pipe does not kink or deform, as these may affect the performance of the system.

Nominal Diameter	Bending Radius (R) Without Aid	Bending Radius (R) with Bending Spring	Bending Radius (R) with Bending Tool
16 × 2.0	5 × d _a	2.0 × d _a	
20 × 2.0	5 × d _a	3.0 × d _a	
26 × 3.0			3.6 × d _a
32 × 3.0			3.6 × d _a
40 × 3.5			4.0 × d _a
50 × 4.0			4.0 × d _a
63 × 4.5			4.5 × d _a

Note: All measurements in mm unless otherwise stated.

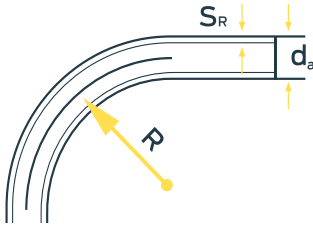

The bending process on Auspex Gas pipe must not result in either indentations or deformations on the inside of the pipe bend. Damage to the PE-X layer of the Auspex Gas pipe may affect the integrity of the system.



Do not use pipes that have kinks, cuts, deep scratches, squashed ends, imperfections or have been in contact with contaminating substances. Such pipe should be cut out and replaced, as these conditions may affect the integrity of the system.

Data Sheet

Dimension (mm)	16	20	25	32	40	50	63
Coefficient of Linear Thermal Expansion in mm/m × K	0.026	0.026	0.026	0.026	0.026	0.026	0.026
Thermal Conductivity in W/M × K	0.45	0.45	0.45	0.45	0.45	0.45	0.45
Gas Volumes Litre/m	0.1112	0.1814	0.2955	0.4752	0.855	1.385	2.29
Pipe Roughness K mm	0.007	0.007	0.007	0.007	0.007	0.007	0.007
Coil Length	50	50	50	25			
Metres Per Length	5	5	5	5	5	5	5
Pipe Weight (G/M)	109	159	229	389	600	900	1200

Spacing of Supporting Devices

Pipe Dimension	Maximum Pipe Clip Clearance
16	1000
20	1250
25	1500
32	2000
40	2000
50	2500
63	2500

Note: All measurements in mm unless otherwise stated. See also AS/NZS 5601. Synthetic clips must be used.

Thermal Changes in Length

Heating and cooling cause pipe length changes.

The coefficient of expansion of Auspex Gas composite pipes is 0.026 mm/m x k.

For further information on Linear Expansion Tables and other expansion bend examples contact your Auspex representative or customer service.

Example Temperature	
Differential ΔT	50 k
Pipe length L	5 m
Coefficient of expansion a	0.026 mm/m.K
Linear expansion ΔL	6.5 mm
ΔL	$= a \times L \times \Delta T$ $= 0.026\text{mm/m.K} \times 5 \text{ m} \times 50 \text{ K}$ $= 6.5 \text{ mm}$

Thermal conductivity = 0.45 W/M x K

UV Resistance

Auspex Gas pipes must be protected against direct sunlight or UV radiation. Consequently, Auspex Gas pipes must be covered during transport or storage if they have been removed from their original packaging. When Auspex Gas pipes are used in a UV stabilised sleeve, adequate UV protection is assured during the installation phase. Furthermore, jackets made from insulating material can undertake the function of UV protection with Auspex Gas pipes (check with the supplier of the insulating material).



According to AS/NZS 5601, multi-layer pipes shall be protected from direct sunlight or any other deteriorating effects. Storage, handling and installation of pipe shall be carried out with care to avoid damage to the pipe or any protective coating.

Fire and Excessive Heat

- According to AS/NZS 5601, Keep Auspex Gas MLP a minimum of 1m from sources of high heat or greater to prevent damage. Final connections to appliances are to be made using certified manual shut-off valves, copper tube, steel pipe or a certified hose assembly
- Keep Auspex Gas pipe 1500mm from slow combustion type stoves and flues used to heat hot water or cooking (wet back type)
- Leave 300mm minimum space between Auspex Gas pipe and light fittings or other electrical fixtures
- Auspex Gas pipe should not be positioned within 150mm of gas or central heating vents or flues
- Where fire collars or the like are required, installers should contact the manufacturer of those products to ensure they have certification for MLP construction

Chemical Resistance

Auspex Gas has been tested and certified to AS 4176.8. This standard covers multi-layer pipe and fittings in domestic gas installations for natural gas and LPG.

Gas pipes must be protected from exposure to

- Bitumen or bitumen strips
- Greases, solvents, and oils
- Contaminated areas as defined by AS/NZS 5601 and AS/NZS 3500

If the Auspex Gas system is used in areas where, for example, aggressive gases, below ground, permanently acting moisture or building materials containing chlorine are to be encountered, the fittings must be protected using RWC silicon wrap.

It is also best practice to protect pipe and fittings with suitable jacketing when similarly exposed or in contact with screed, concrete, mortar, plaster or similar.

RWC Silicone Burial Wrap

When using RWC Silicone Burial Wrap, make an Auspex connection as per AS/NZS 3500 (see Installation Instructions in this manual for details). While leaving the protective film in place, measure the amount of tape needed to completely wrap the fitting. To ensure a proper seal, overlap tape by 25mm past the end of the fitting on every end and 5mm – 10mm between/across the fitting.

Completely cover the fitting by wrapping (overlapping each edge of the tape) the fitting, pulling the tape tight and removing the protective film. The tape will bond to itself within minutes and form an impervious barrier within a few hours.



RWC Silicone
Burial Wrap

Making A Joint

16mm to 25mm Fittings

It is extremely important that the tool instructions supplied with the tool are read in their entirety, and the user becomes familiar with the maintenance, precautions and the proper use of this tool.

The following describes, in general terms, the jointing procedures but should not be regarded as a substitute for reading and applying the detailed instructions supplied with the tool.

1. Select the correct tool and jaw size to suit the fitting to be crimped. The jaws must be examined in terms of possible damage or dirt in the compression area.
2. If utilising a battery operated tool, ensure that the battery is fully charged and attach it to the tool.
3. Insert the jaw and line up the holes in the tool with the hole in the jaw. Push the pin through the hole in the jaw and turn pin to lock. Ensure pin is locked into position prior to commencing crimp. To change the jaw push the pin in and turn pin to unlock.

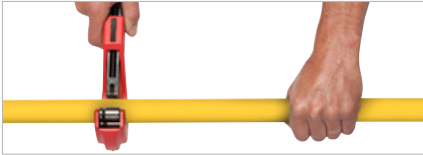

4. Cut the pipe to the required length with the recommended multi-layer pipe cutters.



5. Insert the approved (16-32mm) yellow handle calibrating/deburring tool into the pipe, and then alternately turn in a clockwise and in a counter-clockwise direction. Ensure that a consistent, smooth chamfer is formed on the end of the pipe.



6. Push the pipe over the barbed fitting and at the same time under the crimp ring. The fit should be firm. If the joint feels sloppy or hard to insert, check pipe and fittings. Do not use lubricants. Ensure the pipe is visible in the crimp ring witness hole.

7. Make sure the tool jaws are centralised over the crimp ring at 90° to the joint.

When using the manual tool, close the tool completely to compress the crimp ring. The tool will click at final compression.

When using the battery tool, press the switch until the crimp is completed.



8. When using Auspex hand crimpers, check with the gauge supplied by sliding the opening of the gauge over the compressed ring. If the gauge passes over all parts of the ring without interference, then the joint has been done satisfactorily.

If the gauge experiences any interference, the joint is under crimped. The tool should then be adjusted.

Making A Joint

32mm to 63mm Fittings

It is extremely important that the tool instructions supplied with the tool are read in their entirety, and the user becomes familiar with the maintenance, precautions and the proper use of this tool.

The following describes, in general terms, the jointing procedures but should not be regarded as a substitute for reading and applying the detailed instructions supplied with the tool.

1. Ensure that the battery is fully charged and attach it to the tool.
2. Select the correctly sized Auspex jaw. The jaws must be examined in terms of possible damage or dirt in the compression area.



3. To change the jaw, push the pin in and turn pin to unlock.
4. Insert the jaws and line up the holes in the tool with the hole in the jaw.
5. Push the pin through the hole in the jaw and turn pin to lock.



6. Cut the pipe to the required length with the recommended multi-layer pipe cutters.
7. Insert the approved (16-32mm, 40-50mm, or 63mm) Auspex handle calibrating/deburring tool into the pipe, and then alternately turn in a clockwise and in a counter-clockwise direction. Ensure that a consistent, smooth chamfer is formed on the end of the pipe.



The traditional 16-32mm yellow-handled Auspex deburring tool is still effective after the release of the new black handled universal deburring hand tools.

8. Insert the pipe over the fitting and under the copper ring and push the pipe until it is visible in the slots of the witness hole. This ensures you have pushed the pipe home.



9. By squeezing the back of the jaw, the jaws will open. If you look at the machined profile on the inside of the jaws you will note a slot on each side of the profile.



10. With the jaws open place the fitting inside the jaws so that the raised section of the plastic sight ring fits into the slot in the jaws. Release the jaws so they fit perfectly over the fitting, ensuring that the raised section of the plastic holding ring is still located in the slots in the jaw.



11. Press the switch mechanism until the joint is completed and the piston has retracted back into the body of the tool.
12. Press the back end of the jaws and remove the completed joint.

Troubleshooting

The Auspex Gas system is simple and effective when executed in accordance with the jointing procedures in this manual. However, if sufficient care is not taken, this can result in an ineffective joint.

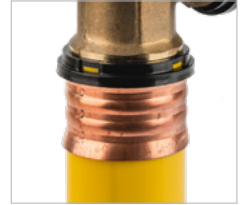

Effective joint on large-bore pipe

Ineffective joints may occur if:

- Using a rotary pipe cutter. This may lead to flaring of the pipe OD resulting in insertion interference with the crimp ring. Use pipe shears in pipe sizes of 32mm and smaller. Ensure cutting tools are sharp and well maintained
- The pipe has been cut badly out of square
- The witness hole is not completely filled (the fitting is not fully inserted in the pipe)
- The copper ring has moved away from the fitting body
- The crimping tool has not been completely closed
- The crimping tool is out of adjustment. Re-adjust tool in accordance with the instructions supplied with the tool, and in this manual
- The crimping tool has not been centred over the copper ring and the jaw has overhung the end of the fitting
- The crimping tool has not been at 90° to the joint being made
- The fitting has been double crimped

Examples of ineffective joints:

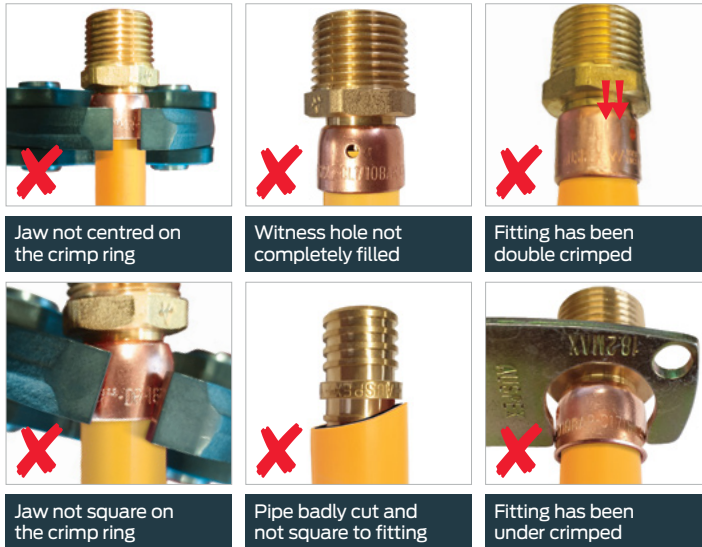

If an ineffective joint is detected:

- Cut out the defective joint and replace with new fitting

Non-compliant fittings that are removed cannot be re-used.

Pipe Sizing

The following example is for natural gas using:

- Supply Pressure 2.75kPa
- Pressure Drop 0.75kPa

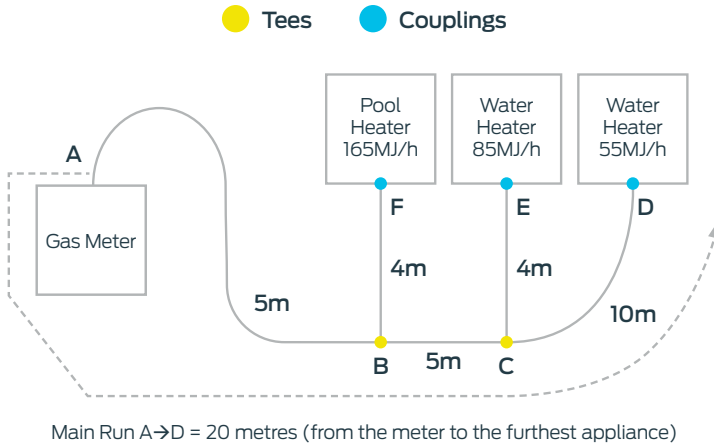

Pipe Section	A→D	A→B	B→C	C→D	C→E	B→F*
Pipe Length	20	5	5	10	4	4
Gas Flow MJ/h	305	165 + 85 + 55 = 305	85 + 55 = 140	55	85	165
Fitting Correction	0.8 + 1.7 + 1.7 = 4m					
Corrected Main Run	24m	24m	24m	24m	24m	24m
Nominal Pipe Size Corrected		32mm	25mm	16mm	20mm	25mm
Nominal Pipe Size Uncorrected		25mm	25mm	16mm	20mm	25mm

* In keeping with gas fitting best practice, if any value is close to the limit, upsize.

Flow tables

LPG-Pressure 2.75kPa

Pressure Drop 0.25kPa (Supply Pressure 2.75kPa) (Mj/h)							
Main Run (m)	Nominal Size (mm)						
	16	20	25	32	40	50	63
2	293	577	1,111	2,058	4,626	8,192	15,341
4	197	388	748	1,385	3,113	5,513	10,323
6	157	308	593	1,099	2,469	4,373	8,188
8	133	261	503	932	2,095	3,710	6,947
10	117	230	443	821	1,844	3,266	6,116
12	105	207	399	739	1,662	2,943	5,510
14	97	190	365	677	1,521	2,694	5,046
16	89	176	339	627	1,410	2,497	4,675
18	84	165	317	587	1,318	2,334	4,371
20	79	155	298	552	1,241	2,198	4,116
25	69	136	262	486	1,092	1,935	3,623
30	62	123	236	438	984	1,743	3,264
35	57	113	217	401	901	1,596	2,989
40	53	104	201	372	835	1,479	2,769
45	50	97	188	348	781	1,383	2,590
50	47	92	177	327	735	1,302	2,438
55	44	87	167	310	696	1,233	2,309
60	42	83	159	295	662	1,173	2,197
65	40	79	152	282	633	1,121	2,099
70	38	76	146	270	607	1,074	2,012
75	37	73	140	259	583	1,033	1,934
80	36	70	135	250	562	995	1,864
85	34	68	130	242	543	961	1,800
90	33	66	126	234	525	930	1,742
95	32	64	122	227	509	902	1,689
100	31	62	119	220	495	876	1,641
120	28	56	107	198	446	790	1,478
140	26	51	98	182	408	723	1,354
160	24	47	91	168	378	670	1,255
180	22	44	85	157	354	626	1,173
200	21	42	80	148	333	590	1,104
250	19	37	70	130	293	519	972
300	17	33	63	118	264	468	876
Correction +mt for fitting	1.7	1.5	0.8	0.7	-	-	-

LPG-Pressure 70kPa

Pressure Drop 10kPa (Supply Pressure 70kPa) (Mj/h)

Main Run (m)	Nominal Size (mm)						
	16	20	25	32	40	50	63
2	3,023	5,950	11,449	21,214	47,670	91,492	180,593
4	2,034	4,004	7,705	14,276	32,080	61,570	121,530
6	1,614	3,176	6,111	11,323	25,446	48,837	96,398
8	1,369	2,694	5,185	9,607	21,588	41,434	81,784
10	1,205	2,372	4,564	8,457	19,004	36,473	71,993
12	1,086	2,137	4,113	7,620	17,123	32,865	64,870
14	994	1,957	3,766	6,978	15,680	30,094	59,400
16	921	1,813	3,489	6,465	14,528	27,883	55,037
18	861	1,695	3,262	6,044	13,582	26,068	51,454
20	811	1,596	3,071	5,691	12,788	24,545	48,448
25	714	1,405	2,704	5,010	11,257	21,606	42,648
30	643	1,266	2,436	4,514	10,144	19,469	38,428
35	589	1,159	2,231	4,133	9,288	17,827	35,188
40	546	1,074	2,067	3,830	8,606	16,517	32,603
45	510	1,004	1,932	3,580	8,046	15,442	30,481
50	480	946	1,819	3,371	7,576	14,540	28,700
55	455	895	1,723	3,193	7,174	13,769	27,179
60	433	852	1,640	3,038	6,826	13,101	25,860
65	414	814	1,566	2,902	6,521	12,516	24,704
70	396	780	1,501	2,782	6,251	11,997	23,680
75	381	750	1,443	2,674	6,009	11,534	22,764
80	367	723	1,391	2,577	5,792	11,116	21,941
85	355	698	1,344	2,490	5,595	10,737	21,194
90	343	676	1,300	2,410	5,415	10,392	20,513
95	333	655	1,261	2,336	5,250	10,076	19,889
100	323	636	1,224	2,269	5,098	9,785	19,314
120	291	573	1,103	2,044	4,594	8,817	17,403
140	267	525	1,010	1,872	4,206	8,073	15,935
160	247	486	936	1,734	3,897	7,480	14,765
180	231	455	875	1,621	3,644	6,993	13,804
200	218	428	824	1,527	3,431	6,585	12,997
250	192	377	725	1,344	3,020	5,797	11,442
300	173	340	654	1,211	2,721	5,223	10,309
Correction +mt for fitting	-	-	-	-	-	-	-

Natural Gas - Pressure 1.1kPa

Pressure Drop 0.075 (Supply Pressure 1.1kPa)							
Main Run (m)	Nominal Size (mm)						
	16	20	25	32	40	50	63
2	94	186	357	662	1,488	2,856	5,638
4	64	125	241	446	1,002	1,922	3,794
6	50	99	191	354	794	1,525	3,010
8	43	84	162	300	674	1,294	2,553
10	38	74	143	264	593	1,139	2,248
12	34	67	128	238	535	1,026	2,025
14	31	61	118	218	490	940	1,855
16	29	57	109	202	454	871	1,718
18	27	53	102	189	424	814	1,606
20	25	50	96	178	399	766	1,513
25	22	44	84	156	351	675	1,332
30	20	40	76	141	317	608	1,200
35	18	36	70	129	290	557	1,099
40	17	34	65	120	269	516	1,018
45	16	31	60	112	251	482	952
50	15	30	57	105	237	454	896
55	14	28	54	100	224	430	849
60	14	27	51	95	213	409	807
65	13	25	49	91	204	391	771
70	12	24	47	87	195	375	739
75	12	23	45	83	188	360	711
80	11	23	43	80	181	347	685
85	11	22	42	78	175	335	662
90	11	21	41	75	169	324	640
95	10	20	39	73	164	315	621
100	10	20	38	71	159	305	603
120	9	18	34	64	144	275	544
140	8	16	32	58	131	252	498
160	8	15	29	54	122	234	461
180	7	14	27	51	114	218	431
200	7	13	26	48	107	206	406
250	6	12	23	42	94	181	357
300	5	11	20	38	85	163	322
Correction +mt for fitting	1.2	1.1	0.6	0.5	-	-	-

Natural Gas - Pressure 2.75kPa

Pressure Drop 0.75 (Supply Pressure 2.75kPa)							
Main Run (m)	Nominal Size (mm)						
	16	20	25	32	40	50	63
2	357	704	1,354	2,509	5,637	10,819	21,355
4	241	473	911	1,688	3,793	7,281	14,371
6	191	376	723	1,339	3,009	5,775	11,399
8	162	319	613	1,136	2,553	4,900	9,671
10	143	280	540	1,000	2,247	4,313	8,513
12	128	253	486	901	2,025	3,886	7,671
14	118	231	445	825	1,854	3,559	7,024
16	109	214	413	764	1,718	3,297	6,508
18	102	200	386	715	1,606	3,083	6,085
20	96	189	363	673	1,512	2,902	5,729
25	84	166	320	592	1,331	2,555	5,043
30	76	150	288	534	1,200	2,302	4,544
35	70	137	264	489	1,098	2,108	4,161
40	65	127	244	453	1,018	1,953	3,855
45	60	119	229	423	951	1,826	3,604
50	57	112	215	399	896	1,719	3,394
55	54	106	204	378	848	1,628	3,214
60	51	101	194	359	807	1,549	3,058
65	49	96	185	343	771	1,480	2,922
70	47	92	178	329	739	1,419	2,800
75	45	89	171	316	711	1,364	2,692
80	43	85	164	305	685	1,314	2,595
85	42	83	159	294	662	1,270	2,506
90	41	80	154	285	640	1,229	2,426
95	39	77	149	276	621	1,192	2,352
100	38	75	145	268	603	1,157	2,284
120	34	68	130	242	543	1,043	2,058
140	32	62	119	221	497	955	1,884
160	29	58	111	205	461	885	1,746
180	27	54	104	192	431	827	1,632
200	26	51	97	181	406	779	1,537
250	23	45	86	159	357	685	1,353
300	20	40	77	143	322	618	1,219
Correction +mt for fitting	1.7	1.5	0.8	0.7	-	-	-

Natural Gas - Pressure 2.75kPa

Pressure Drop 1.5 (Supply Pressure 2.75kPa)							
Main Run (m)	Nominal Size (mm)						
	16	20	25	32	40	50	63
2	531	1,045	2,012	3,728	8,377	16,077	31,734
4	357	704	1,354	2,509	5,637	10,819	21,355
6	284	558	1,074	1,990	4,471	8,582	16,939
8	241	473	911	1,688	3,793	7,281	14,371
10	212	417	802	1,486	3,339	6,409	12,651
12	191	376	723	1,339	3,009	5,775	11,399
14	175	344	662	1,226	2,755	5,288	10,438
16	162	319	613	1,136	2,553	4,900	9,671
18	151	298	573	1,062	2,387	4,581	9,042
20	143	280	540	1,000	2,247	4,313	8,513
25	125	247	475	880	1,978	3,797	7,494
30	113	222	428	793	1,782	3,421	6,753
35	104	204	392	726	1,632	3,133	6,183
40	96	189	363	673	1,512	2,902	5,729
45	90	176	340	629	1,414	2,714	5,356
50	84	166	320	592	1,331	2,555	5,043
55	80	157	303	561	1,261	2,420	4,776
60	76	150	288	534	1,200	2,302	4,544
65	73	143	275	510	1,146	2,199	4,341
70	70	137	264	489	1,098	2,108	4,161
75	67	132	254	470	1,056	2,027	4,000
80	65	127	244	453	1,018	1,953	3,856
85	62	123	236	437	983	1,887	3,724
90	60	119	229	423	951	1,826	3,605
95	59	115	222	411	923	1,771	3,495
100	57	112	215	399	896	1,719	3,394
120	51	101	194	359	807	1,549	3,058
140	47	92	178	329	739	1,419	2,800
160	43	86	164	305	685	1,314	2,594
180	41	80	154	285	640	1,229	2,426
200	38	75	145	268	603	1,157	2,284
250	34	66	127	236	531	1,019	2,011
300	30	60	115	213	478	918	1,812
Correction +mt for fitting	1.7	1.5	0.8	0.7	-	-	-

Natural Gas - Pressure 5.10kPa

Pressure Drop 1.5 (Supply Pressure 5 – 10kPa)							
Main Run (m)	Nominal Size (mm)						
	16	20	25	32	40	50	63
2	539	1,061	2,041	3,782	8,498	16,311	32,195
4	363	714	1,374	2,545	5,719	10,976	21,665
6	288	566	1,089	2,019	4,536	8,706	17,185
8	244	480	924	1,713	3,849	7,386	14,580
10	215	423	814	1,508	3,388	6,502	12,834
12	194	381	733	1,358	3,053	5,859	11,565
14	177	349	671	1,244	2,795	5,365	10,589
16	164	323	622	1,153	2,590	4,971	9,811
18	154	302	582	1,077	2,421	4,647	9,173
20	145	285	548	1,015	2,280	4,376	8,637
25	127	250	482	893	2,007	3,852	7,603
30	115	226	434	805	1,808	3,471	6,851
35	105	207	398	737	1,656	3,178	6,273
40	97	191	368	683	1,534	2,945	5,812
45	91	179	344	638	1,434	2,753	5,434
50	86	169	324	601	1,351	2,592	5,116
55	81	160	307	569	1,279	2,455	4,845
60	77	152	292	542	1,217	2,336	4,610
65	74	145	279	517	1,163	2,231	4,404
70	71	139	268	496	1,114	2,139	4,222
75	68	134	257	477	1,071	2,056	4,059
80	65	129	248	459	1,033	1,982	3,912
85	63	124	240	444	997	1,914	3,778
90	61	120	232	430	965	1,853	3,657
95	59	117	225	416	936	1,796	3,546
100	58	113	218	404	909	1,744	3,443
120	52	102	197	364	819	1,572	3,102
140	48	94	180	334	750	1,439	2,841
160	44	87	167	309	695	1,333	2,632
180	41	81	156	289	650	1,247	2,461
200	39	76	147	272	612	1,174	2,317
250	34	67	129	240	538	1,033	2,040
300	31	61	117	216	485	931	1,838
Correction +mt for fitting	1.7	1.5	0.8	0.7	-	-	-

Manual Crimping Tool

Adjustment of Tool

1. With the tool open, apply light pressure inwards.
2. The handle should be positioned somewhere between 225-250mm apart.
3. If adjustment is required, back off locking screw 3-4 full turns.
4. Turn adjusting screw in $\frac{1}{4}$ turn increments, adjusting screw slot should finish in a vertical or horizontal position.
5. Recheck opening of handle measurement.
6. When set, tighten down locking screw.
7. Conduct a crimp and gauge check. Re-adjust tool if crimp not satisfactory.



Ratcheting

Move Ratchet Lever up or down to suit movement.

Nominal Adjustment

225-250mm.

Gauge

Ensure crimped connection passes through gauge opening on all sides of the joint.

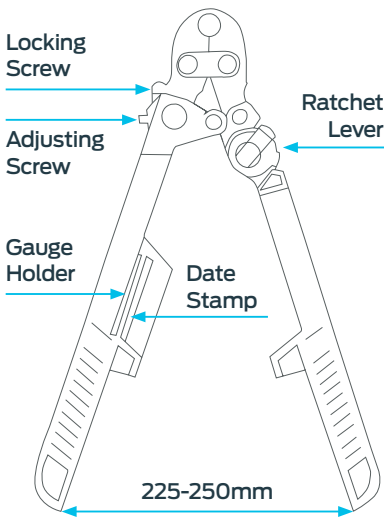

IMPORTANT

- A tool that is out of adjustment can cause a faulty joint
- A tool that is set with excessive pressure can damage both tool and fitting
- A worn or damaged tool should be replaced

Joining To Other Materials

Threaded fittings are available to make the transition between Auspex pipes and other materials. Specialised and tested adaptor fittings are also available. Please see catalogue or contact Auspex.

When Joining To Copper

- a.** Flared copper compression to Auspex crimp adaptors are available.
- b.** Brazing adaptors are available, designed so that one end can:
 - Fit over 15mm, 20mm, 25mm and 32mm copper pipe
 - Fit into expanded 15mm, 20mm or 25mm copper pipe
 - Fit into standard copper or brass brazed fittings
 - When brazing these adaptors they **MUST** be cold before inserting into the PE-X pipe
- c.** Push fit copper adaptors are available:
 - Square cut the copper pipe
 - Remove any burrs or loose material
 - Ensure the outside of the pipe is free of scratches, marks etc.
 - Push the copper fully into the fitting using a twisting motion
 - Make sure the copper is not oval or out of round
 - Do not use on annealed copper or coated copper e.g. chrome coating
- d.** B-Press (crimp) copper to Auspex:
 - See catalogue for available conversion fittings
 - Follow the B-Press installation instruction for the copper crimp end
 - Follow the Auspex installation instruction for crimping the PE-X end of the fitting



Auspex

Product List Pipes & Fittings



Black Pipe

16mm × 5m Straight	XAP401605	1537750
16mm × 50m Coil	XAP401650	1537759
16mm × 100m Coil	XAP4016100	1537754
20mm × 5m Straight	XAP412005	1537763
20mm × 50m Coil	XAP412050	1537773
20mm × 100m Coil	XAP4120100	1537767
25mm × 5m Straight	XAP422505	1537777
25mm × 25m Coil	XAP422525	1537781
32mm × 5m Straight	XAP433205	1537783



Black Pipe - Pre-Lagged

16mm × 5m	XAP401605LAG	1537863
20mm × 5m	XAP412005LAG	1537864

Corrugated Sleeving

16mm × 25m Coil 23mm Corr – Black	XAP401625COR	1537756
20mm × 25m Coil 23mm Corr – Black	XAP412025COR	1537769
20mm × 25m Coil 32mm Corr – Black	XAP412025COR32	1537868
20mm × 25m Coil 32mm Corr – Purple	XAP412025LILCOR32	1538263
16mm × 25m Coil 23mm Corr – Red	XAP401625RCOR	1537756

Lilac Pipe

16mm × 5m Straight	XAP401605LIL	1537752
16mm × 50m Coil	XAP401650LIL	1537761
20mm × 5m Straight	XAP412005LIL	1537765
20mm × 50m Coil	XAP412050LIL	1537775
25mm × 5m Straight	XAP422505LIL	1537779
25mm × 25m Coil	XAP422525LIL	1537862



Green Pipe

16mm × 5m Straight	XAP401605G	1537751
16mm × 50m Coil	XAP401650G	1537760
20mm × 5m Straight	XAP412005G	1537764
20mm × 50m Coil	XAP412050G	1537774
25mm × 5m Straight	XAP422505G	1537778



Red Pipe

16mm × 5m Straight	XAP401605R	1537753
16mm × 50m Coil	XAP401650R	1537762
20mm × 5m Straight	XAP412005R	1537766
20mm × 50m Coil	XAP412050R	1537776
25mm × 5m Straight	XAP422505R	1537780
25mm × 25m Coil	XAP422525R	1537782

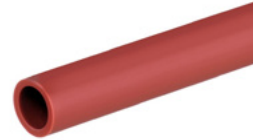

Black Pipe - Pre Insulated

16mm × 25m Coil R.3 – 9mm Wall	XAP401625R3	1546460
16mm × 25m Coil R.8 – 13mm Wall	XAP401625R8	1546461
20mm × 25m Coil R.3 – 9mm Wall	XAP412025R3	1546452
20mm × 25m Coil R.8 – 13mm Wall	XAP412025R8	1546463
25mm × 25m Coil R.3 – 9mm Wall	XAP422525R3	1546464
25mm × 25m Coil R.8 – 13mm Wall	XAP422525R8	1546465



Multi-Layer Water Straight

16mm × 5m	APW401605	1546708
20mm × 5m	APW412005	1546710
25mm × 5m	APW422505	1546712
32mm × 5m	APW433205	1546714
40mm × 5m	APW444005	1546716
50mm × 5m	APW455005	1546717
63mm × 5m	APW466305	1546718

Multi-Layer Water Coils

16mm × 50m	APW401650	1546709
16mm × 100m	APW4016100	1603579
20mm × 50m	APW412050	1546711
20mm × 100m	APW4120100	1603580
25mm × 50m	APW422550	1546713
32mm × 25m	APW433225	1546715
32mm × 50m	APW433250	1603581

Multi-Layer Water Coils Insulated

16mm × 50m	APW401650R3	1546719
20mm × 50m	APW412050R3	1546720
25mm × 25m	APW422525R3	1546721
32mm × 25m	APW433225R3	1546722

Multi-Layer Gas Straight

16mm × 5m	APG401605	1539740
20mm × 5m	APG412005	1539742
25mm × 5m	APG422505	1539744
32mm × 5m	APG433205	1539746
40mm × 5m	APG444005	1546824
50mm × 5m	APG455005	1546827
63mm × 5m	APG466305	1546829

Multi-Layer Gas Coils

16mm × 50m	APG401650	1539741
20mm × 50m	APG412050	1539743
25mm × 50m	APG422550	1539745
32mm × 25m	APG433225	1539747



Couplings

16mm × 16mm	A008X	1546527
20mm × 20mm	A016X	1546528
25mm × 25mm	A020X	1546590
32mm × 32mm	A030X	1546616
20mm × 16mm	A058X	1546529
25mm × 20mm	A060X	1546591
25mm × 16mm	A021X	1546592
32mm × 20mm	A031X	1546618
32mm × 25mm	A032X	1546617
40mm × 25mm	A033X	1546792
40mm × 32mm	A034X	1546793
50mm × 32mm	A035X	1546805
50mm × 40mm	A036X	1546806
63mm × 40mm	A037X	1546818
63mm × 50mm	A038X	1546819
40mm × 40mm	A040X	1546790
50mm × 50mm	A042X	1546803
63mm × 63mm	A044X	1546816



A008X



A032X



A044X

Tees

16mm × 16mm × 16mm	A362X	1546523
20mm × 20mm × 20mm	A370X	1546524
25mm × 25mm × 25mm	A374X	1546593
32mm × 32mm × 32mm	A382X	1546624
20mm × 20mm × 16mm	A412X	1546525
20mm × 16mm × 16mm	A367X	1546520
20mm × 16mm × 20mm	A444X	1546526
25mm × 16mm × 20mm	A368X	1546595
25mm × 16mm × 25mm	A422X	1546596
25mm × 20mm × 16mm	A423X	1546597
25mm × 20mm × 20mm	A424X	1546598
25mm × 20mm × 25mm	A425X	1546599
25mm × 25mm × 16mm	A418X	1546600
25mm × 25mm × 20mm	A416X	1546601
16mm × 16mm × 20mm	A475X	1546559
32mm × 32mm × 25mm	A385X	1546626
32mm × 32mm × 20mm	A383X	1546627
32mm × 25mm × 25mm	A384X	1546628
32mm × 20mm × 20mm	A388X	1546629



A362X



A475X



A388X

40mm × 40mm × 40mm	A392X	1546791
50mm × 50mm × 50mm	A394X	1546804
63mm × 63mm × 63mm	A396X	1546817
40mm × 32mm × 32mm	A434X	1546797
40mm × 40mm × 32mm	A437X	1546798
50mm × 50mm × 25mm	A442X	1546811
50mm × 50mm × 32mm	A443X	1546812
50mm × 50mm × 40mm	A447X	1546813
63mm × 63mm × 32mm	A449X	1546820
63mm × 63mm × 40mm	A450X	1546821
63mm × 63mm × 50mm	A451X	1546822

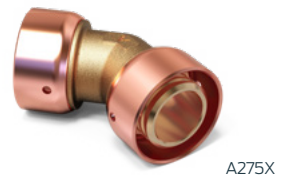
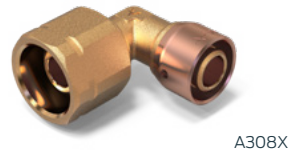
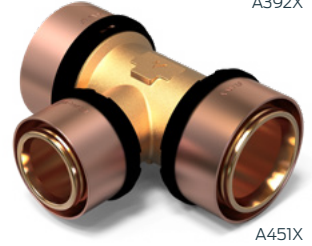

Elbows

16mm × 16mm	A248X	1546521
20mm × 20mm	A256X	1546522
25mm × 25mm	A260X	1546605
32mm × 32mm	A270X	1546631
25mm × 20mm	A257X	1546602
20mm × 16mm	A247X	1546603
16mm × 1/2" Male	A280X	1546555
20mm × 1/2" Male	A251X	1546604
25mm × 1" Male	A261X	1546579
32mm × 1" Male	A262X	1546580
16mm × 1/2" Female	A308X	1546639
20mm × 3/4" Female	A253X	1546937
20mm × 3/4" Male	A254X	1546938
25mm × 3/4" Female	A255X	1546939
32mm × 1" Female	A264X	1546785
40mm × 40mm	A274X	1546788
25mm × 25mm (45 degrees)	A275X	1546778
32mm × 32mm (45 degrees)	A276X	1546787
40mm × 40mm (45 degrees)	A277X	1546789
50mm × 50mm (45 degrees)	A278X	1546802
63mm × 63mm (45 degrees)	A279X	1546815
50mm × 50mm	A284X	1546801
63mm × 63mm	A287X	1546814

Lugged Elbows (Male)

16mm × 1/2" (73mm)	A350X	1546530
16mm × 1/2" (88mm)	A357X	1546538
16mm × 1/2" (100mm)	A352X	1546636
16mm × 1/2" (200mm)	A351X	1546547
16mm × 1/2" (230mm)	A353X	1546574
20mm × 1/2" (65mm)	A358X	1546637
20mm × 1/2" (200mm)	A359X	1546578
20mm × 3/4" (200mm)	A354X	1546573
25mm × 3/4" (75mm)	A348X	1546606
20mm × 1/2" (95mm)	A356X	1546577
32mm × 1" (230mm)	A289X	1546936



A289X

Lugged Elbows (Female)

16mm × 1/2" BSP	A334X	1546531
20mm × 3/4" BSP	A340X	1546546
25mm × 3/4" BSP	A349X	1546780



A334X

Brazing Tails

16mm Male	A600X	1546532
20mm Male	A621X	1546545
25mm Male	A602X	1546609
32mm Male	A603X	1546632
25mm × 20mm Male	A601X	1546610
16mm Female	A605X	1546519
20mm Female	A606X	1546533
25mm Female	A607X	1546608
32mm Female Brazing Tail	A608X	1546633
20mm × 15mm Female	A604X	1546675



A600X



A608X

Push Fit Copper Adaptors

16mm × 15mm Push Fit	A009X	1546570
20mm × 20mm Push Fit	A017X	1546571



A009X

Compression Adaptors

16mm × 15mm Copper	A610X	1546540
20mm × 20mm Copper	A612X	1546542



A610X

B-Press Adaptors (Water)

16mm × DN15 Copper	A009XBP	1546651
20mm × DN20 Copper	A017XBP	1546652
25mm × DN25 Copper	A018XBP	1546653
32mm × DN25 Copper	A030XBP	1546836
40mm × DN32 Copper	A040XBP	1546837
50mm × DN40 Copper	A042XBP	1546838
63mm × DN50 Copper	A044XBP	1546839
32mm × 32mm × DN20 Copper	A383XBP	1546655
32mm × 32mm × DN25 Copper	A385XBP	1546654
25mm × 25mm × DN20 Copper	A416XBP	1546657



A030XBP



A383XBP

System Adaptors

16mm Auspex × 16mm SDR 7.4 PE-X Adaptor	A009XPX	1546548
20mm Auspex × 20mm SDR 7.4 PE-X Adaptor	A017XPX	1546549
16mm SDR 7.4 PE-X × 16mm SDR 7.4 PE-X × 16mm Auspex Tee	A364XPX	1546648
20mm SDR 7.4 PE-X × 20mm SDR 7.4 PE-X × 20mm Auspex Tee	A372XPX	1546645
16mm Auspex × 16mm SDR9 PE-X Adaptor	A009XSB	1546649
20mm Auspex × 20mm SDR9 PE-X Adaptor	A017XPN	1546650
16mm Auspex × 18mm PB Adaptor	A009XPB	1546550
18mm PB × 18mm PB × 16mm Auspex Tee	A364XPB	1546644
22mm PB × 20mm Auspex Adaptor	A017XPB	1546646
22mm PB × 22mm PB × 20mm Auspex Tee	A370XPB	1546647



A009XPX

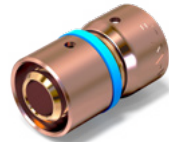

A009XSB

Threaded BSP Adaptors (Male)

16mm × 1/2"	A120X	1546534
20mm × 3/4"	A139X	1546535
25mm × 1"	A140X	1546615
32mm × 1 1/4"	A150X	1546623
20mm × 1/2"	A138X	1546612
25mm × 3/4"	A142X	1546614
20mm × 1"	A141X	1546613
32mm × 1"	A151X	1546621
40mm × 1 1/4"	A152X	1546794
50mm × 1 1/2"	A154X	1546807
63mm × 2"	A156X	1546823



A120X



A150X

Threaded BSP Adaptors (Female)

16mm × 1/2"	A072X	1546536
20mm × 3/4"	A088X	1546537
25mm × 1"	A094X	1546625
32mm × 1 1/4"	A096X	1546622
20mm × 1/2"	A087X	1546635
25mm × 3/4"	A093X	1546620
32mm × 1"	A095X	1546619
16mm × 1/2" Wing Back Connector	A097X	1546557
20mm × 3/4" Wing Back Connector	A098X	1546514
40mm × 1 1/4"	A100X	1546795
50mm × 1 1/2"	A102X	1546808

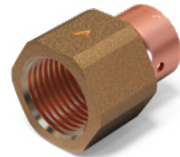

A072X

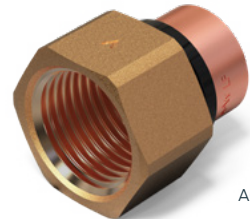

A096X

Loose Nut and Tail (Female)

16mm × 1/2" Coupling	A526X	1546539
16mm × 1/2" Elbow	A308X	1546639
20mm × 1/2" Coupling	A528X	1546673
20mm × 3/4" Coupling	A530X	1546554
20mm × 3/4" Elbow	A310X	1546638
25mm × 1" Coupling	A521X	1546558

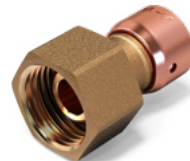

A526X

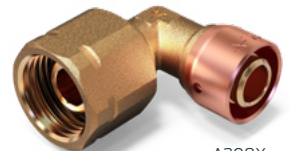

A308X

End Caps

16mm	A514X	1546543
20mm	A518X	1546544
25mm	A520X	1546630
32mm	A524X	1546634
40mm	A540X	1546800



A514X

Spare Copper Rings (With Plastic Inserts)

16mm	A001X	1546575
20mm	A002X	1546576
25mm	A003X	1546643
32mm	A004X	1546941
40mm	A005X	1546942
50mm	A006X	1546943
63mm	A007X	1546944



A004X

Sink Sets

200mm Right Angle Centre	A632X	1546507
200mm Right Angle Centre 43.6mm Body Height	A643X	1546509
300mm Right Angle Centre	A630X	1546506
300mm Side Entry Centre	A640X	1546505

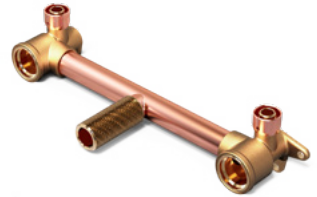

A632X



Shower Sets

150mm Bottom Entry Shower Set Centres, Short Copper Riser and Auspex Barb	A652X	1546501
200mm Bottom Entry Shower Set Centres Short Copper Riser and Auspex Barb	A650X	1546503
200mm Bottom Entry Shower Breech Centre with 43.6mm Body Height	A663X	1546510
150mm Top Entry Shower Set Centres Short Copper Riser and Auspex Barb	A657X	1546500
200mm Top Entry Shower Set Centres Short Copper Riser and Auspex Barb	A655X	1546502
200mm Top Entry Shower Breech Centre with 43.6mm Body Height	A656X	1546556
150mm Side Entry Shower Set Centres Short Copper Riser and Auspex Barb	A651X	1546504



A652X

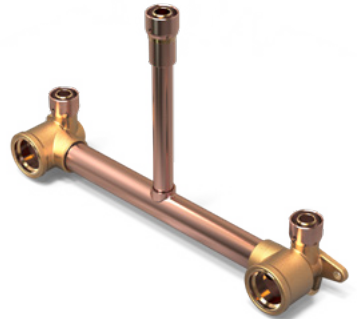

A656X

Ball Valves

16mm × 16mm	A670X	1546564
20mm × 20mm	A672X	1546565
25mm × 25mm	A674X	1546566
16mm × 15mm Female BSP	A680X	1546567
20mm × 20mm Female BSP	A682X	1546568
25mm × 25mm Female BSP	A684X	1546569

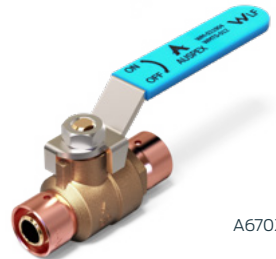

A670X

Barrel Union Couplings

20mm	A622X	1546587
25mm	A623X	1546588
32mm	A624X	1546589

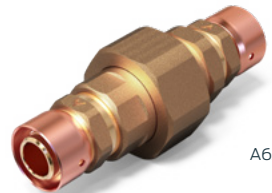

A622X

B-Press Gas Adaptors

16mm × DN15 Gas Copper	A009XG	1546581
20mm × DN20 Gas Copper	A017XG	1546582
25mm × DN25 Gas Copper	A018XG	1546583
20mm × DN15 Gas Copper	A019XG	1546584
25mm × DN20 Gas Copper	A021XG	1546585
32mm × DN25 Gas Copper	A022XG	1546586
40mm × DN32 Gas Copper	A026XG	1546825
50mm × DN40 Gas Copper	A027XG	1546828
63mm × DN50 Gas Copper	A038XG	1546835
40mm × DN40 Gas Copper	A039XG	1546826



A009XG



A022XG

Threaded Tees (Female)

20mm × 20mm × Rp1/2"	A455X	1546664
25mm × 25mm × Rp1/2"	A386X	1546663
32mm × 32mm × Rp1/2"	A387X	1546662
40mm × 40mm × Rp1"	A436X	1546799

Threaded Tees also available under Auspex Fire Product Range

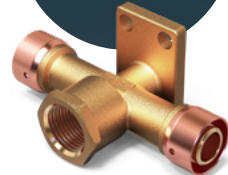

A455X

Threaded Tees (Male)

20mm × 20mm × Rp1/2"	A341X	1546667
25mm × 25mm × Rp1/2"	A342X	1546666
32mm × 32mm × Rp1/2"	A343X	1546665

DuoPEX Gas Adaptors

16mm × 16mm GPM	A009XM	1435881
20mm × 20mm GPM	A017XM	1435882
25mm × 26mm GPM	A020XM	1435883
32mm × 32mm GPM	A030XM	1435884
40mm × 40mm GPM	A040XM	1546830
50mm × 50mm GPM	A042XM	1546831
63mm × 63mm GPM	A044XM	1546832



A030XM

DuoPEX Water Adaptors

16mm × 16mm DPW	A009XD	1603672
20mm × 20mm DPW	A017XD	1546841
25mm × 26mm DPW	A020XD	1546842
32mm × 32mm DPW	A030XD	1546843
40mm × 40mm DPW	A040XD	1546844
50mm × 50mm DPW	A042XD	1546845
63mm × 63mm DPW	A044XD	1546846



A030XD

Crimping Tools

16mm	AP2116RN	1534107
20mm	AP2120RN	1534109
25mm	AP2125RN	1534111



AP2120RN

Crimp Ring Repair Tools

25mm × 20mm × 16mm	AP22252016	1544077
40mm × 32mm	AP224032	1546945
63mm × 50mm	AP226350	1546946



AP224032

Gauges

20mm × 16mm	AP172016	1544120
25mm	AP1725	1544125

Bend Stabilisers

16mm	AP1816	1544152
20mm	AP1820	1544155

RWC Silicone Burial Wrap

50mm × 3m (Self-adhesive)	VC870	1539194
------------------------------	-------	---------



VC870

Deburring/Calibration Tools

16mm - 32mm	A211632X	1435295
40mm - 50mm	A214050X	1435296
63mm	A2163X	1435297



A211632X

Rothenberger Compact TT

Rothenberger Compact TT Tool	8078100
---------------------------------	---------

Rothenberger Compact TT Jaws

16mm	7701227
20mm	7701228
25mm	7701229
32mm	7701224
40mm	7701225



Rothenberger Romax 4000

Rothenberger 4000 Tool 18V 7701304

Rothenberger Romax 4000 Jaws

Auspex 3000/4000 Jaw 16mm 7701235

Auspex 3000/4000 Jaw 20mm 7701236

Auspex 3000/4000 Jaw 25mm 7701237

Auspex 3000/4000 Jaw 32mm 7701233

Auspex 3000/4000 Jaw Adaptor 7701197

Auspex 3000/4000 Jaw 40mm 7701234

Auspex 3000/4000 Chain Jaw 40mm 7701253

Auspex 3000/4000 Chain Jaw 50mm 7701249

Auspex 3000/4000 Chain Jaw 63mm 7701250

Pipe Preparation Tools

Auspex Crimp Ring Repair Tool 1544077

Auspex Gas Calibrating Tool 16-32mm 1539759

Auspex Deburring Tool 40-50mm 1435296



Couplings

16mm × 16mm	APSS011616	1118050
20mm × 20mm	APSS012020	1118051
25mm × 25mm	APSS012525	1118074
20mm × 16mm	APSS022016	1118052
25mm × 20mm	APSS022520	1118077



APSS011616

Tees

16mm × 16mm × 16mm	APSS03161616	1118053
20mm × 20mm × 20mm	APSS03202020	1118054
25mm × 25mm × 25mm	APSS03252525	1118076
20mm × 16mm × 16mm	APSS04201616	1118055
20mm × 20mm × 16mm	APSS04202016	1118057
20mm × 16mm × 20mm	APSS04201620	1118056
25mm × 25mm × 20mm	APSS04252520	1118088



APSS04252520

Elbows

16mm × 16mm	APSS051616	1118058
20mm × 20mm	APSS052020	1118060
20mm × 16mm	APSS052016	1118059
25mm × 25mm	APSS052525	1118075



APSS051616

Lugged Elbows (Male)

16mm × 1/2" (73mm)	APSS061615S	1118061
16mm × 1/2" (100mm)	APSS061615100	1118080



APSS061615S

Lugged Elbows (Female)

16mm × 1/2" Female BSP	APSS071615F	1118062
------------------------	-------------	---------

Brazing Tails

16mm Female	APSS0816F	1118063
20mm Female	APSS0820F	1118064



APSS0816F

Threaded BSP Adaptors (Male)

16mm × 1/2" Male BSP	APSS091615	1118065
20mm × 3/4" Male BSP	APSS092020	1118066
25mm × 1" Male BSP	APSS092525	1118078

Threaded BSP Adaptors (Female)

16mm × 1/2" Female BSP	APSS101615	1118067
20mm × 3/4" Female BSP	APSS102020	1118068
25mm × 1" Female BSP	APSS102525	1118079

Sink Sets

300mm Right Angle Centre	APSS11RA	1118069
--------------------------	----------	---------

Shower Sets

150mm Bottom Entry Centre	APSS12BEC	1118070
150mm Top Entry Centre	APSS12TEC	1118085

End Caps

16mm	APSS1416	1118071
20mm	APSS1420	1118072

Loose Nut And Tail

16mm × 1/2"	APSS191615	1118073
-------------	------------	---------

System Adaptors

18mm PB × 16mm AP Adaptor Coupling	APSS151618PB	1118081
22mm PB × 20mm AP Adaptor Coupling	APSS152022PB	1118089
18mm PB × 18mm PB × 16mm AP Adaptor Tee	APSS15181816PB	1118082
22mm PB × 22mm PB × 20mm AP Adaptor Tee	APSS15222220PB	1118090
16mm AP × 16mm SDR 7.4 PE-X Coupling	APSS151620	1118083
20mm AP × 20mm SDR 7.4 PE-X Coupling	APSS152020	1118084



APSS091615



APSS101615



APSS11RA

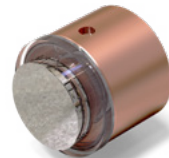

APSS1416



APSS151618PB

Questions and Answers

Auspex Cross Linked Polyethylene (PE-X) Water Pipes 16-32mm

What are Auspex PE-X pipes made from?	Auspex PE-X Water pipes are made from Cross-Linked Polyethylene in sizes 16-32mm
What do the Auspex fittings with coloured protection caps mean?	<ul style="list-style-type: none">▪ Black Caps – Universal fittings for both Gas and Water installations▪ Yellow Caps – Suitable for Gas only installations▪ Blue Caps - Suitable for Water only installations
What is Auspex PE-X Water pipes maximum temperature and pressure rating?	Auspex PE-X Water pipes are designed to operate with a maximum working pressure of 2000kPa at 20 degrees and 1000kPa at 70 degrees.
Can Auspex be used on re-circulating lines ring mains?	Yes, Auspex PE-X pipes can be used for re-circulating hot water ring mains however must not exceed 70 degrees at 500kPa and a maximum chlorine level of 1.2ppm must be maintained.
Can all Auspex fittings be used for Water and Gas?	<p>Although most Auspex fittings are suitable for both Water and Gas installations not all Auspex fittings are suitable. Each Auspex fitting has a coloured protection cap which determines its suitability. Only black capped fittings are suitable for water and gas installations.</p> <p>For further information please refer to the Auspex Fitting Product Guide.</p>
Are there adaptors for Auspex to other Piping systems?	Yes, Auspex offers an extensive range of adaptors to connect directly with all PE-X SDR9, SDR7.4 pipes and Polybutylene (PB) systems to 16 and 20mm sizes. Auspex also has a comprehensive range of B-Press copper adaptors to 16-63mm sizes. In addition, Auspex has also developed a range of DuoPEX Water and Gas MLP adaptors to 16-63mm sizes. For further information please refer to the Auspex Adaptors Chart
What is a SDR Rating?	SDR is the “Standard Dimensional Ratio” and is defined as the ratio of the nominal outside diameter to the nominal wall thickness of the pipe. E.g. the higher the SDR the thinner the wall thickness of the pipe. Auspex is a SDR 9 pipe, manufactured using PE-X100, providing maximum flow rates, temperature and pressure ratings.
Are Auspex fittings required to be protected when buried?	Yes, Auspex fittings are suitable for burial however RWC Silicone Wrap should be used to protect the fitting from any environmental or chemical contamination within the ground. Nb – Petroleum tape is not suitable for use with PE-X pipes.
Why does the Auspex 32mm fittings used for PE-X pipes have O-rings?	All Auspex 32mm fittings with a black cap can be used for both water and gas applications. O-rings are required in all 32mm fittings to provide a reliable connection when used with PE-X or MLP pipes.

Can Silicone be used with the Auspex system?	Yes, neutral cure silicone is suitable for use with the Auspex system. AS/NZS 3500.1 allows neutral cure silicone to be used around PE-X pipes to fill annular space drilled through a stud or plate.
Are Auspex PE-X pipes suitable for use in cold climates?	The optimal ambient temperature for a PE-X pipe is above 0 C, however installation is possible down to -20 C if appropriate insulation protection of the PE-X pipe is installed
Are Auspex PE-X pipes suitable for use in direct sunlight?	Auspex PE-X pipes manufactured after March 2010 meet AS2492 requirements for carbon black content. As far as the standard is concerned relating to UV stability, the black pipe meets all the requirements however it is considered good plumbing practice to protect all PE-X pipes installed externally.
Can Auspex PE-X Water Pipes be used for Reverse Osmosis?	Both Auspex PE-X and Auspex Water MLP pipes are suitable for a Reverse Osmosis installation but must only use with Auspex Stainless Steel fittings which are available in sizes 16-25mm

Auspex Multi-Layer Water Pipes (MLP) 16-63mm

<p>What are Auspex Multi-Layer Water pipes (MLP) made from?</p>	<p>Auspex Water MLP pipe in sizes 16-63mm, consist of an PE-X black inner layer, a middle aluminium layer and an PE-RT white outer layer, known as PE-X/AL/PE-RT. Suitable for use in potable water and various HVAC heating and cooling water applications.</p>
<p>Can Auspex fittings be used with Auspex MLP pipes?</p>	<p>The wall thickness of both 16-63mm Auspex MLP water and gas pipes have been specifically engineered to match all Auspex fittings providing a universal fitting solution with all Auspex Pipes. Additionally, all Auspex fittings in sizes 32-63mm use a special grade HNBR O-ring which is suitable for water and gas applications.</p>
<p>Is Auspex Water MLP suitable for compressed air installations?</p>	<p>Auspex Water MLP is suitable for use as a compressed air system with upstream oil filters (oil-free) up to 10 bar operating pressure and max. 40 C operating temperature, including for vacuum systems, suction pipes up to -0.8 bar.</p>
<p>What is the pressure rating of Auspex Water MLP?</p>	<p>Auspex Water MLP is a PN14 with a maximum constant operating pressure of 1400kPa at 20 C and a maximum temperature rating of 70 C at 1000kPa. For leak testing purposes and in compliance with AS3500, Auspex MLP can be hydrostatically pressurised to 1500kPa.</p>
<p>What is the minimum temperature Auspex Water MLP can be used?</p>	<p>Auspex Water MLP has a minimum continuous operating temperature of 5 C making it suitable for chilled water lines. Insulation is required to protect against condensation. The optimal ambient temperature for proper installations is above 0 C, however installation is possible down to -20 C, further requiring insulation protection against pipes freezing.</p>
<p>Is Auspex Water MLP suitable for use for heating systems?</p>	<p>Auspex Water MLP can be used without limitations in heating applications as a heating pipe within the given systems capacity ratings. It is also suitable for radiant heating as the aluminium core provides an oxygen tight closed system.</p>
<p>Can Auspex Water MLP be used on re-circulating Hot Water lines?</p>	<p>Yes, Auspex PE-X pipes can be used for re-circulating hot water ring mains however must not exceed 70 degrees at 500kPa with a maximum chlorine level of 1.2ppm must be maintained.</p> <p>Additionally for heating applications. E.g. radiant heating to a maximum 70 C continuously operating temperature.</p>
<p>What is the thermal conductivity of Auspex Water MLP?</p>	<p>Auspex Water MLP thermal conductivity = 0.45W/M x k.</p> <p>AS3500 requires a minimum insulation of R-Value of 0.3, therefore no PE-X or MLP piping material will meet this requirement without suitable thermal insulation.</p>
<p>How must thermal change in pipe length be calculated?</p>	<p>Heating and cooling cause pipe expansion and pipe work movement. The coefficient of expansion of Auspex Water MLP pipes is 0.026mm/m x k. For further information on linear expansion, refer to the example provided within this manual.</p>

Which Auspex pipes require to be chamfered with an Auspex deburring tool?

Auspex MLP for water and gas pipes must be chamfered using the Auspex deburring tool to clean the inner edge of the pipe of burrs or sharp edges that could damage the O-rings within the fitting. This process also re-rounds the pipe for easier fitting insertion. Nb - Auspex 32mm PE-X pipe must also be chamfered as all Auspex 32mm fittings have O-rings

Are DuoPEX fittings compatible for use with Auspex Multi-Layer pipe?

DuoPEX fittings aren't compatible for use with either Auspex Water or Gas MLP pipes. Auspex fittings are also not compatible for use with either DuoPEX Gas or Water pipes. A range of Auspex to DuoPEX adaptors are available to transition between systems.

Is Auspex Water MLP suitable for use in direct sunlight?

Auspex Water MLP is not suitable for use in direct sunlight.

Auspex Multi-Layer Gas Pipes (MLP) 16-63mm

<p>What are Auspex Multi-Layer Gas pipes (MLP) made from?</p>	<p>Auspex Gas MLP pipe in sizes 16–63mm, consist of an PE-X black inner layer, a middle aluminium layer and an PE-X yellow outer layer, known as PE-X/AL/PE-X. Suitable for use in Natural Gas and LPG applications. Suitable for applications up to an operating temperature of 80 C as per AS/NZS 5601.</p>
<p>Is there a difference between Auspex Gas and DuoPEX Gas pipe sizing tables?</p>	<p>Yes, there is a minimal difference between these systems which will vary between installations. Each Auspex Gas installation should be sized using the Auspex Gas tables provided.</p>
<p>Can Auspex fittings used with PE-X pipes be used with Auspex MLP pipes?</p>	<p>The wall thickness of both 16–63mm Auspex MLP gas and water pipes have been specifically engineered to match all Auspex fittings providing a universal fitting solution with all Auspex Pipes. Additionally, all Auspex fittings in sizes 32–63mm use a special grade HNBR O-ring which is suitable for gas and water applications.</p>
<p>What do the Auspex fittings with coloured protection caps mean?</p>	<ul style="list-style-type: none"> ▪ Black Caps – Universal fittings for both Gas and Water installations ▪ Yellow Caps – Suitable for Gas only installations ▪ Blue Caps - Suitable for Water only installations
<p>Which Auspex pipes require to be chamfered with an Auspex deburring tool?</p>	<p>Auspex MLP for gas and water pipes must be chamfered using the Auspex deburring tool to clean the inner edge of the pipe of burrs or sharp edges that could damage the O-rings within the fitting. This process also re-rounds the pipe for easier fitting insertion. Nb - Auspex 32mm PE-X pipe must also be chamfered as all Auspex 32mm fittings have O-rings.</p>
<p>Are DuoPEX fittings compatible for use with Auspex Multi-Layer pipe?</p>	<p>DuoPEX fittings aren't compatible for use with either Auspex Gas or Water MLP pipes. Auspex fittings are also not compatible for use with either DuoPEX Water or Gas pipes. A range of Auspex to DuoPEX adaptors are available to transition between systems.</p>
<p>Is Auspex Water MLP suitable for use in direct sunlight or outdoor use?</p>	<p>Auspex Gas MLP is not suitable for use in direct sunlight as it is not UV sable and needs to be protected against UV exposure as per AS/NZS 5601.</p>
<p>Do plumbers need to be certified to use Auspex Gas?</p>	<p>Some states and territories require certification from the manufacturer to complete gas installations. Plumbers are advised to check with their local gas authorities for more information. Auspex does offer a certification course that we recommend plumbers complete, regardless of their respective state-based requirements. This ensures plumbers have a good understanding of the system.</p>
<p>Can Auspex MLP Gas pipes be buried below ground.</p>	<p>Yes, however fittings should be protected by using RWC silicone wrap. This will help provide the best long-term protection. Care should be taken in contaminated soils. In such cases pipes and fittings should be protected.</p>

<p>Does the Auspex MLP Gas System adapt direct to copper.</p>	<p>Yes, a range of B-Press adaptors are available from copper to Auspex Gas in all pipe sizes, 16-63mm.</p>
<p>Is cold bending the Auspex MLP Gas pipe, ok?</p>	<p>Yes, cold bending the Auspex MLP Gas pipe is ok however care must be taken to ensure no kinks. If the pipe is kinked it should be replaced. Typically sizes 16 and 20mm pipes are suitable for cold bending. For greater directional changes when using Auspex MLP pipes in sizes 25-63mm, both 90- and 45-degrees bends are available.</p>
<p>Can Auspex Gas MLP adaptor to other MLP gas systems?</p>	<p>Although copper and DuoPEX adaptors are available to connect with Auspex Gas, no other adaptors are available to connect with other MLP gas systems. Only through a thread fitting connection can Auspex Gas be connected to another MLP gas system.</p>

Auspex Tooling for PE-X (16-32mm) and MLP (16-63mm)

What battery tools are approved for use with the Auspex system?	Rothenberger offer a range of battery-operated tools approved for use with both Auspex PE-X and MLP pipes across the complete range of 16-63mm Auspex fittings. Additionally, only approved Auspex hand crimping tools for sizes 16, 20 and 25mm are approved for use with the Auspex system.
Does the Auspex hand crimping tools require calibration?	To ensure all fitting connections are crimped correctly the Auspex hand crimping tool must be calibrated. Use the QR code to follow the simple steps required. Basic hand tool maintenance is also important. Ensure all moving parts are always well lubricated.
How do I know a Auspex crimp connection has been completed correctly?	<p>Having calibrated the Auspex hand tool the first crimp connection completed must be checked with an Auspex testing gauge. If the gauge passes over the copper crimp ring without interference the connection has been adequately crimped. If not, the hand tool calibration must be checked again.</p> <p>All 32, 40, 50 and 63mm sizes require a Rothenberger battery-operated tool to complete a fitting connection. The TH profile crimping jaws compress the copper crimp ring, leaving two groove lines in the ring. All Rothenberger battery-operated tools must be maintained and serviced as per manufacturer guidelines to ensure all Auspex crimp connections completed satisfactorily.</p>
Do Auspex have a hand crimping tool for 25mm sizes available?	Auspex hand crimping tools are available in sizes 16, 20 and 25mm.
How do I service my Auspex tools?	<p>All Rothenberger battery operated tools must be serviced by an approved service agent. Tool maintenance is of critical importance. Speak with your local Reece branch to organise your battery-operated tool service and a loan tool if required.</p> <p>Auspex hand crimping are easy to service and maintain. Use the QR code to follow the simple steps required. If, however, your business requires a tool box training session, contact your local Reece branch who will organise an Auspex representative to assist.</p>
Can I use a non Auspex brand deburring tool?	32mm PE-X and 32, 40, 50 and 63mm MLP pipes must be deburred to ensure a clean, smooth inner pipe surface to protect the fittings O-rings. Auspex offer a new range deburring tools suitable for this application which have been engineered specifically for Auspex pipes. Alternatively, DuoPEX deburring tools in sizes 40,50 and 63mm can be used with new Auspex MLP pipes.

<p>Are the original DuoPEX crimping jaws compatible with the new Auspex system?</p>	<p>DuoPEX crimping jaws in sizes 16, 20 and 26mm are NOT suitable for use with the new Auspex system. Only approved Auspex crimping jaws can be used on Auspex sizes 16, 20 and 25mm fittings.</p> <p>DuoPEX crimping jaws in sizes 32,40,50, 63mm are however compatible for use with the new Auspex fitting range in the same sizes. The Auspex fitting design in sizes 32,40,50 and 63mm were designed to utilise existing DuoPEX crimping tools.</p>
<p>What are the approved methods of cutting a Auspex PE-X pipe?</p>	<p>PE-X pipes must be cut using a quality cutting tool with sharp and clean blade. Damaged blades should be replaced. Either a Rothenberger PE-X pipe shear or ratchet style cutter is recommended. Other quality PE-X pipe cutters are also suitable. Never use a hacksaw to cut a PE-X pipe.</p>
<p>What are the approved methods of cutting a Auspex MLP pipe?</p>	<p>MLP pipes must be cut using a quality rotational tube cutting tool with a sharp and clean blade. Damaged blades should be replaced. After the pipe has been cut the end of it must be deburred to clean the inner pipe wall of any sharp edges. Never use a hacksaw to cut a Multi-Layer Pipe (MLP).</p>
<p>If a fitting is dropped and the copper crimp ring damaged, can it still be used?</p>	<p>Auspex crimp ring repair tools are available to repair the copper ring by rounding it out. Alternatively, replacement copper crimp rings are also available to purchase.</p>



Auspex

Customer Service

Telephone (03) 9770 3600
Facsimile (03) 9768 3415
Email salesauspex@rmc.com.au

auspex.com.au

For operating parameters outside those stated in the manual, please contact Customer Service.

Contents of this brochure are subject to change, please visit our website for the most up-to-date product information.



Lead Free

AS 2492
AS/NZS 2537
WMKA 1711-1
WMKA 2058



Australian Standard

SMKP 25517
SMK 41080

AU-APG-MN0885R1



Reliance Worldwide Corporation (Aust). Pty. Ltd.
ABN 71 004 784 301
27-28 Chapman Place, Eagle Farm, QLD 4009, Australia