

REEFE rainpro®



RAIN TO MAINS SYSTEM

RM5000-5

RPSE PUMP with RM1500-2

INSTALLATION &
INSTRUCTION MANUAL

OWNERS COPY

WARRANTY & INSTRUCTION MANUAL



RM1500-2

SUBMERSIBLE PUMP SYSTEM WITH RPSE AND RAINPRO RM1500-2 RAIN TO MAINS BACKUP VALVESET

****PLEASE LEAVE THIS GUIDE IN A SAFE PLACE FOR THE OWNER****

IMPORTANT INSTALLATION GUIDELINES:

Mandatory installation condition: the premises where the pump is installed, and the power circuit to which it is connected, must be protected by an rcd (safety switch) – do not install pumps without this protection.

- All parts shown are WaterMarked & certified for Potable Water
- Fittings may differ from the image shown due to variations in design
- Do not adjust the PRV, warranty is void if adjusted
- **Read and follow the instructions in the pages following**

IMPORTANT:

1. If installing close to a wall or other fixture, use barrel-union connections to allow removal if ever required.
2. Must use 25mm white rigid PVC pipe



WaterMark Quality System Doc # RQS.1059 Ver.20190925

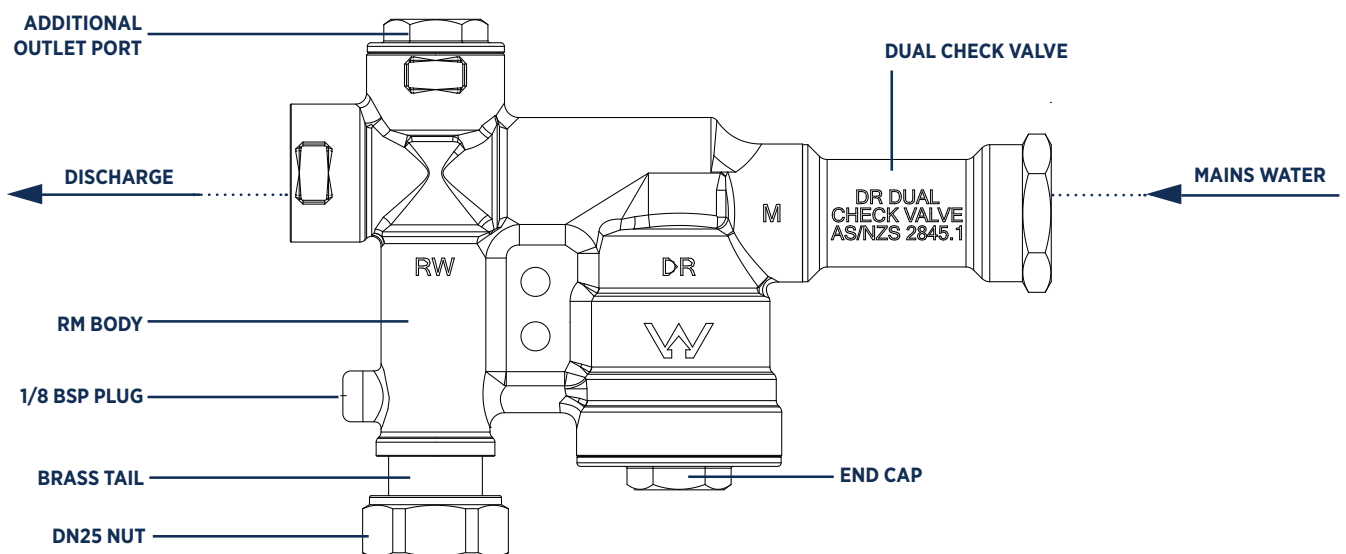

INSTALLATION INSTRUCTIONS

RM1500-2 VALVE

INTRODUCTION

The RM1500-2 and RM1600-2 Valves are fully automatic mechanical rainwater/mains water changeover devices designed for pressure pump supply systems for harvesting rainwater for the toilet, laundry and household applications with automatic mains backup. It is suitable for up to 2 toilets and washing machine and an extra tap outlet

FEATURES

- Easy to install
- Patent design
- Solid Brass mounting bracket (optional)
- Watermark approved to WMTS477/LN60075
- Does not require regular maintenance
- No electrical consumption - No electronic components
- Solid brass construction - Fully weatherproof -Built to last
- Suitable for any pressure pump with sufficient head pressure
- Can be mounted in any position
- Built-in dual check valve for backflow prevention
- 2 Year warranty

OPERATION

The RM1500-2 and RM1600-2 Valves will always prioritize the use of rainwater over mains water when rainwater is available and will automatically switch over to mains water in the event of the rainwater tank running low or electrical failure.

When rainwater has been replenished or power has been restored to the pump, the RM1500-2 and RM1600-2 valves will automatically prioritize back to rainwater.

The pump is only active when rainwater is being drawn from the water tank, it does not operate when the RM1500-2 and RM1600-2 Valve has switched to mains position.

The pump controller starts and stops the pump when it detects a demand - for example flushing a toilet or using a washing machine.

The operating mechanism of the RM1500-2 and RM1600-2 Valves are a unique patent design, it works by hydraulic water pressure created by the pump to close one inlet fully before opening the other inlet. This ensures an extremely reliable mechanism using few moving parts and no electronic components and no energy consumption.

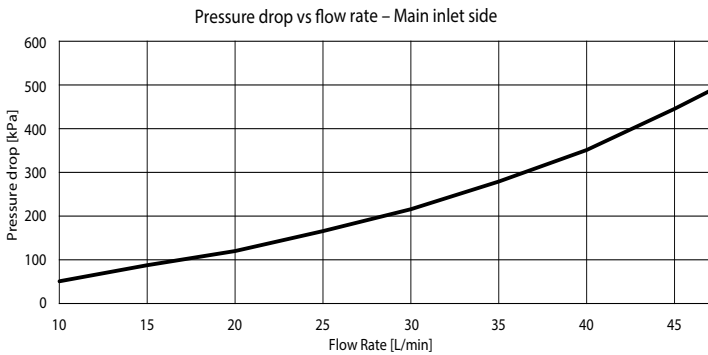

Pressure drop versus flow rate between the mains water inlet side and the outlet of the device

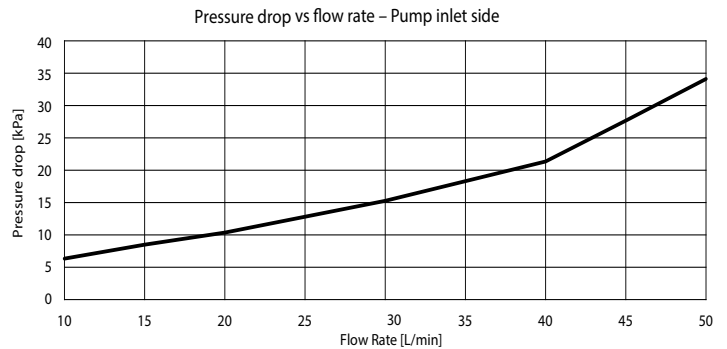

Pressure drop versus flow rate between the rainwater inlet side and the outlet of the device

CONNECTION

All plumbing connections should be carried out by a licensed plumber.

Step 1.

The RM1500-2 or RM1600-2 Valve is fitted onto the pump controller as shown in Fig 1. Lock up the 1" BSP F loose nut with the rubber washer supplied, do not over tighten.

Step 2.

Connect mains water to the RM1500-2 or RM1600-2 Fig 2.

Step 3.

Connect outlet to the premises.

Fig 3. Shows a typical installation for a submersible pump.

Fig 4. Shows the RM1500-2 or RM1600-2 mounted to the wall/ other surface using the optional bracket

NOTE:

The RM1500-2 or RM1600-2 Valve can be installed in any position and location, it does not require to be installed on the pump as shown in diagram.

Connection of the pump should be carried out to manufacturer's instructions, it is recommended that a Y-Strainer be fitted between the tank and pump.

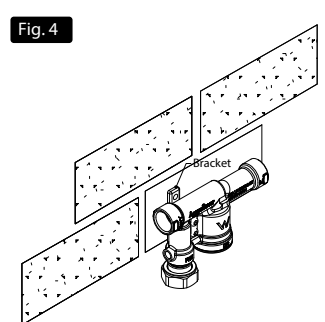
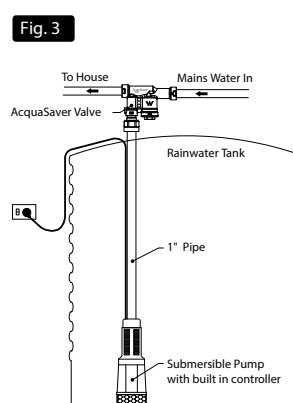
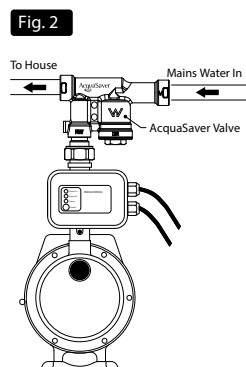
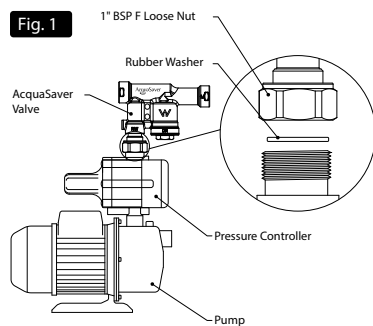

SPECIFICATIONS

Meets Requirements of WMTS477/LN60075

Complies to WMTS477/LN60075 when installed by a licensed plumber

NOTE: According to WMTS477/LN60075 maximum allowable pressure in buildings is 500 KPa

*Ensure proper protection against freezing weather. Complies to AS/NZS 3500.1 when installed by a licenced plumber

	RM1500-2	RM1600-2
Max Mains Pressure	500KPa	500KPa
Max Pump Pressure	600KPa	600KPa
Min Pump Pressure	350KPa	300KPa
Max Flow Rate	100L/Min	50L/Min
Max Water Temperature	50C	40C
Min Water Temperature	0C	0C
Pump Inlet	25mm, 1" FBSP	25mm, 1" FBSP
Mains Water In	25mm, 1" FBSP	25mm, 1" FBSP
Outlet	25mm, 1" FBSP	20mm, 3/4" FBSP
Weight	1.6Kg	0.85Kg

IMPORTANT INSTALLATION & WARRANTY CONDITIONS - EXTERNAL PUMPS

- 1) The mains supply must not exceed 500kPa refer AS/NZS 3500.1
- 2) The pump must have flooded suction (gravity feed of tank-water) with an inlet pipe not less than the size of the pump inlet (typically 25mm)
- 3) The suction must have a Y-Strainer fitted (on the inlet from tank)
- 4) Mains supply must have an isolation valve (ball-valve)
- 5) Tank supply must have an isolation valve (ball-valve)
- 6) ALL CONNECTIONS must be with Barrel-Unions
- 7) Most pump warranties are conditional upon a pump cover being fitted

IMPORTANT INSTALLATION & WARRANTY CONDITIONS - SUBMERSIBLE PUMPS

- 1) The mains supply must not exceed 500kPa refer AS/NZS 3500.1
- 2) The pump must be easily accessible for repair or servicing
- 3) If the pump has a float switch, ensure it CANNOT get stuck on the side of the tank or under baffles or similar -warranty service does not cover this situation.
- 4) Mains supply must have an isolation valve fitted (ball-valve)
- 5) ALL CONNECTIONS must be with Barrel-Unions
- 6) For underground tanks, the installation must be designed and constructed to allow easy access, for removal or replacement of the pump, warranty does not include costs of digging up gardens etc!

TROUBLESHOOTING

SYMPTOM	CAUSE	REMEDY
No water is delivered from pump or pump performance is decreased	Rainwater tank is empty. No Power. Isolation Valve is shut. Pump is not primed. Y-Strainer is blocked.	Wait for tank to fill. Check power supply & plug. Restart pump. Open isolation Valve. See pump owners manual on priming pump. Clean Y-Strainer.
No water is delivered from mains	No water from mains. Debris in valve.	Check isolation valve on water meter. Open bleed plug
Pump continually runs	Leak in the plumbing system. E.g. Toilet or tap leaking. Faulty pump	Repair Leak. Contact pump manufacturer.

MAINTENANCE

The RM1500-2 or RM1600-2 Valve does not require any regular maintenance however there are things you can do to ensure its most reliable operation.

- Fit a Y-Strainer
- Cleaning your gutters
- Cleaning the inlet strainer on rainwater tank

WARRANTY INFORMATION

RM1500-2 and RM1600-2 warranty for Australia and New Zealand

The RM1500-2 and RM1600-2 valve is guaranteed for a period of 2 years from the date of original purchase to be free of material or manufacturing defects. Should any part fail as a result of such defects within this period, the RM1500-2 and RM1600-2 valve will be repaired or replaced by the manufacturer, free of charge. The RM1500-2 and RM1600-2 valve also has a LIMITED LIFETIME WARRANTY on all brass components, any brass component will be replaced free of charge if it fails in normal use during its life.

This warranty applies in all states and territories in Australia and New Zealand. The warranty period commences on the day of the original purchase of the RM1500-2 and RM1600-2 valve. Evidence of this purchase must be provided when claiming repairs or replacement, it is recommended you retain all receipts. Both warranties are subject to conditions by the original purchaser with all conditions set out in the installation and operating instructions. Failure to comply with these instructions, damage or breakdown caused by fair wear and tear, negligence, misuse, incorrect installation, chemical or additives in the water, corrosive or abrasive water, inadequate conditions, attempting repairs or accidents, are not covered by this warranty.

Our goods come with guarantees that cannot be excluded under the Australian Consumer Law. If you are a consumer as defined by the Australian Consumer Law, you are entitled to a replacement or refund for a major failure and for compensation for any other reasonably foreseeable loss or damage. You are also entitled to have the goods repaired or replaced if the goods fail to be of acceptable quality and the failure does not amount to a major failure. The above conditions form part of the instructions and do not over-ride your statutory rights.

INSTALLATION OPTIONS





CORRECT INSTALLATION

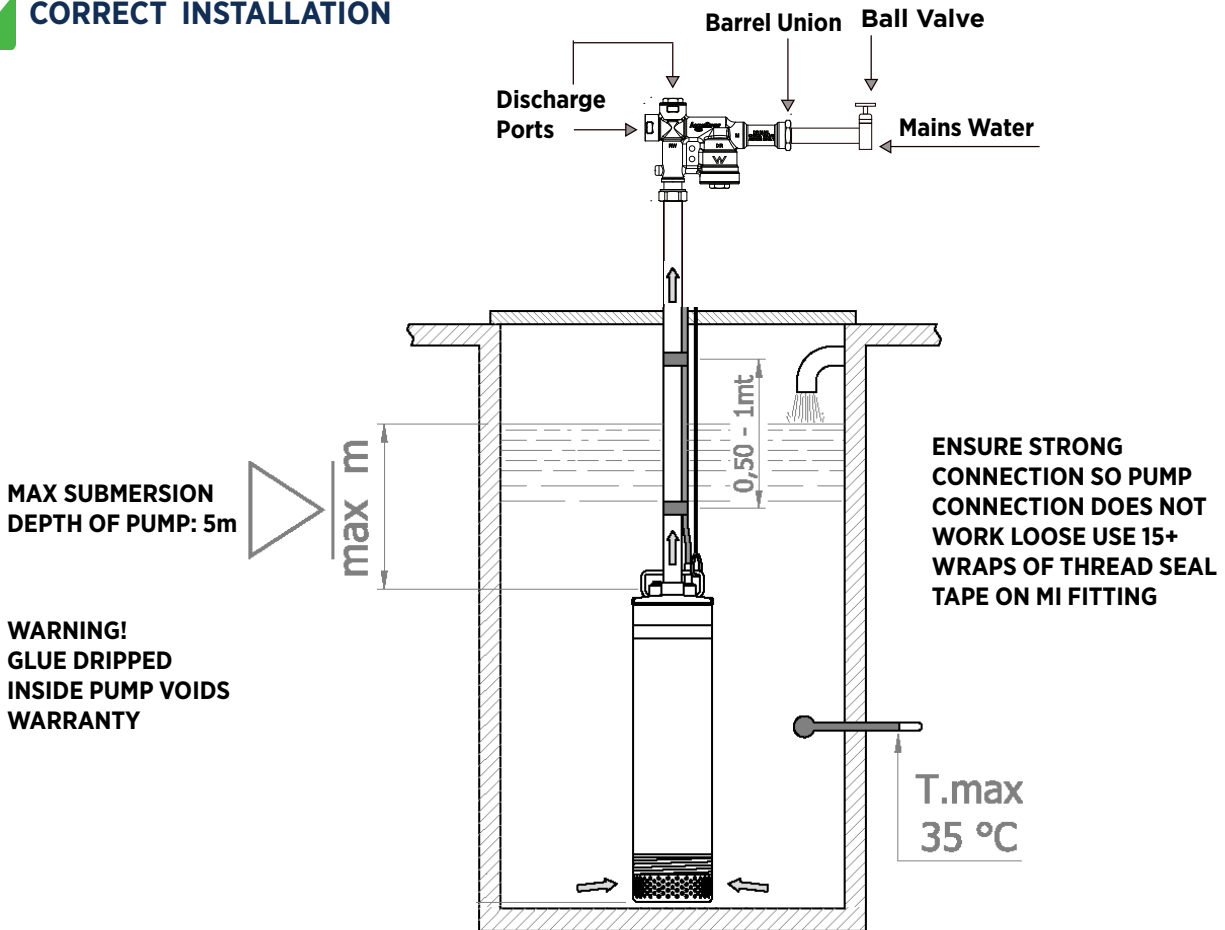

INCORRECT INSTALLATION

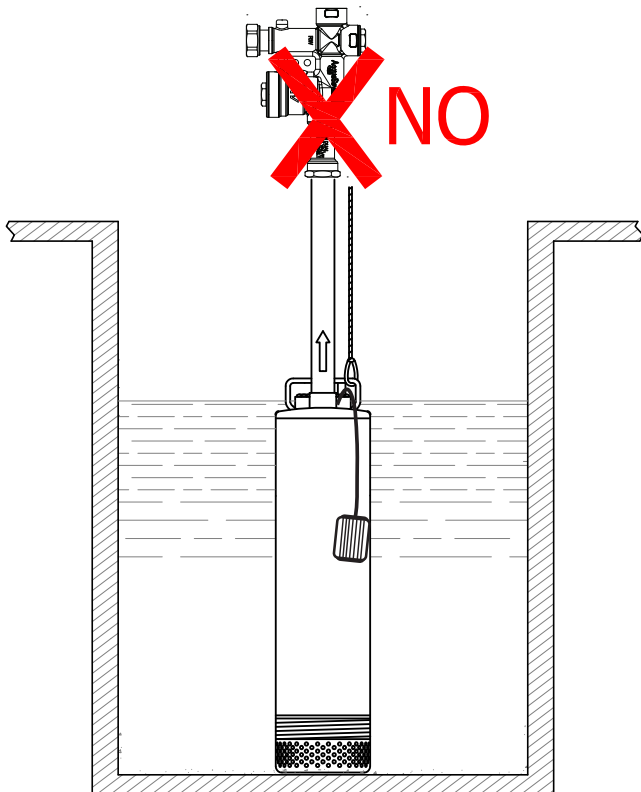

INCORRECT INSTALLATION

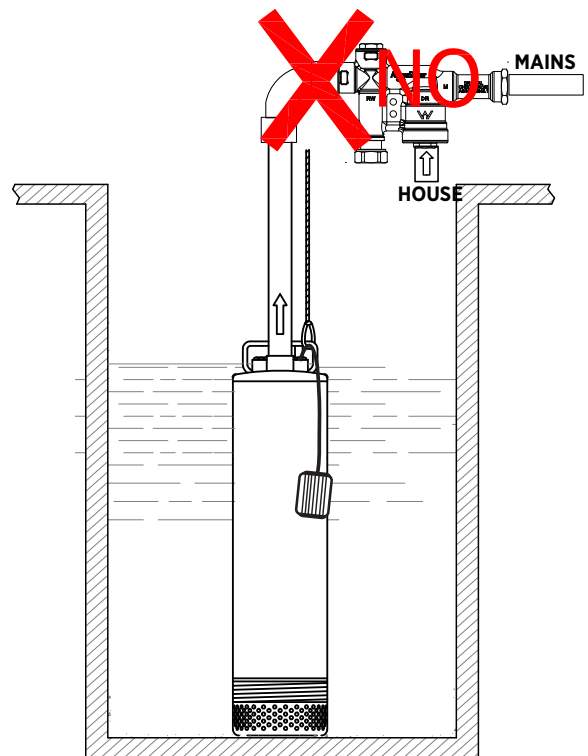

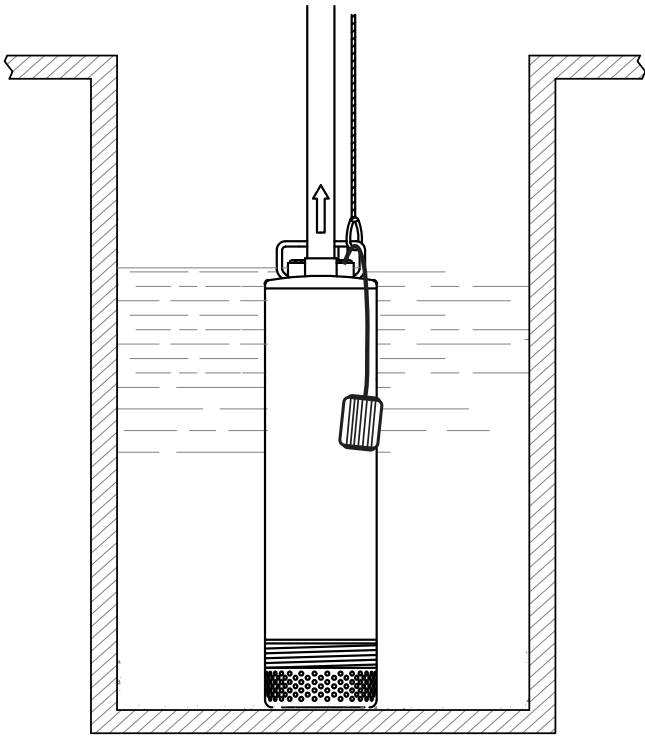

PUMP SHOULD BE AT THE BOTTOM OF THE TANK

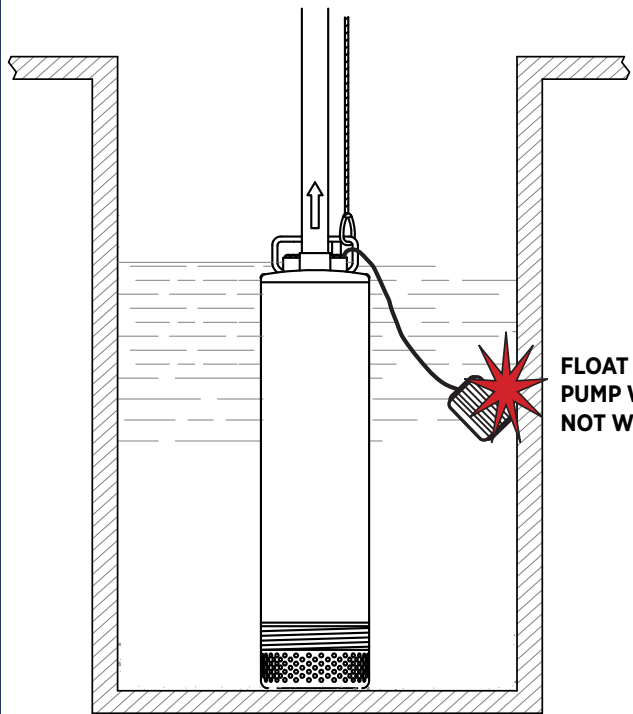

**FLOAT STUCK
PUMP WILL
NOT WORK**

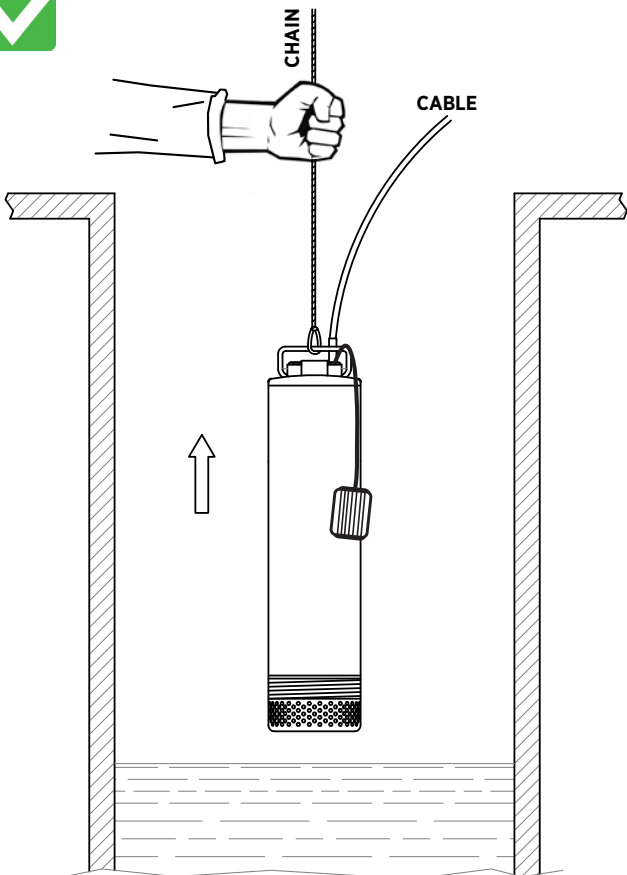

LIFT THE PUMP USING A CHAIN/ROPE THROUGH THE HANDLE

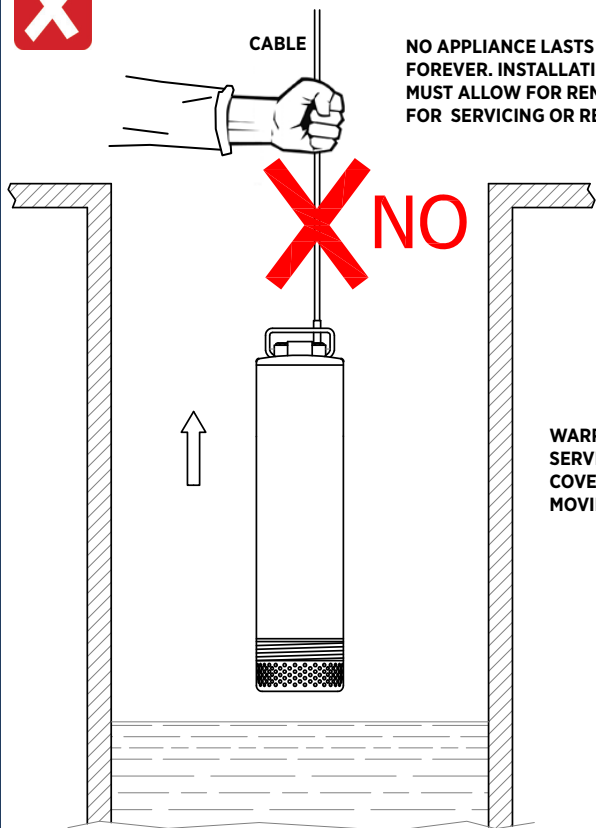

**NO APPLIANCE LASTS
FOREVER. INSTALLATION
MUST ALLOW FOR REMOVAL
FOR SERVICING OR REPAIRS**

**WARRANTY
SERVICE DOES NOT
COVER COST OF
MOVING TANK**

NEVER LIFT THE PUMP FROM THE CABLE

IMPORTANT INSTALLATION & WARRANTY CONDITIONS

1. The mains supply must not exceed 500kPa refer AS/NZS 3500.1
2. **A “First-flush-diverter” or similar device must be installed, and /or a filter screen through which all the incoming water passes before entering the tank,** to prevent debris from entering the tank.
3. **Install the pump UPRIGHT in the tank.** The length of the pump must be vertical, it must not be on an angle off vertical, it must not be horizontal.
4. DO NOT install it in such a manner that it would require a person to get inside the tank to remove/repair it. Install the valve-set external of the tank.
5. **You MUST use 25mm or larger POLY or PVC pipe** connected to the discharge of the pump. DO NOT CONNECT COPPER or GALV PIPE or 13/18/20mm POLY/PVC PIPE to this pump. Do not install the valve-set directly onto the pump as this will cause malfunction.
6. VERY IMPORTANT: **Ensure that the connection to the outlet of the pump is robust and sealed VERY well.** Use 15 wraps of thread-seal tape on the male thread. DO NOT USE glue unless you are CERTAIN that you will not drip glue inside the pump.
7. **Glue or other substances dripped inside the pump voids warranty.** Do NOT fit threaded fitting to the pump then glue pipe to that fitting as glue will drip inside the pump. Glue the fitting and allow it to dry BEFORE attaching the threaded fitting. If the fitting leaks, it will cause cycling of the pump, this is not warranty – this is the installer’s responsibility.
8. Ensure that the pump will not knock against the side of the tank during start-up, or operation or stopping.
9. **No electrical appliance lasts forever** - the pump must be easily accessible for repair or servicing - if the rainwater tank is installed under eaves, or under a deck or any other structure, ensure the pump can be easily removed.
10. For **underground tanks**, the installation must be designed and constructed to allow easy access, for servicing and repairs to the pump. In the unlikely event of pump failure, warranty does not include costs of digging up gardens and re-running electrical cables, etc.
11. **If the pump has a float switch, ensure it CANNOT get stuck** on the side of the tank or under baffles or similar - warranty service does not cover this situation. FOR PUMPS WITH FLOATS: The water level will need to be 250mm to 800mm high inside the tank, for the pump to start.
12. **Isolation valves must be fitted (ball-valve or gate-valve) on Mains supply and discharge.**
13. A Barrel-Union must be fitted external of the tank to allow easy servicing of the pump, install it after the elbow to avoid it twisting loose from the pump starting & stopping.
14. It is the INSTALLERS responsibility to check the pumps operation prior to leaving the site CHECK ALL CONNECTIONS: Ensure all fittings and joints are watertight and airtight. Leaks will cause the pump to cycle on & off continuously, this is not a fault of the pump.
15. All Electrical Wiring & Power Outlet & Cable protection must be in accordance with applicable Australian Standards.
16. It is recommended to install a pressure tank (approximately 2L capacity) on the discharge pipework, anywhere between the pump and the first fixture, closer to the pump is preferred.
17. IMPORTANT NOTICE RE THE STOPPING FUNCTION: **In some situations the pump will cycle a few times after each use. THIS IS NOT A WARRANTY FAULT,** it is a normal function of the internal pump controller releasing excess pressure when there is some “bounce” or “give” in the pipework or connected fixtures – it is often caused by toilet cisterns or a short discharge pipe or flex in pipes. It is not a fault with the pump.
18. **Some air can be pumped when the tank is low in water** – this is not a fault it is normal operation.
19. **WARNING: NO RCD/SAFETY SWITCH IN THE POWER CIRCUIT? DO NOT INSTALL PUMPS!**
WARNING: DO NOT ATTEMPT ELECTRICAL REPAIRS OF ANY SORT UNLESS YOU ARE AN AUSTRALIAN-LICENSED ELECTRICIAN

HOW THE SYSTEM WORKS

1. When the Rainwater tank is empty/nearly empty, the pump controller will sense there is insufficient water and turn the pump off (or for submersible pump with float, the float switch will turn the pump off)
2. When this happens, the submersible pump shuts down.
3. Mains water (Town-Water) will flow freely so you always have water when the Rainwater is “off”.
4. Some pressure difference may be noticed between the different water supplies – this is normal, it is not a fault with the system – the mains water from the RM5000-3 Valve-set may be at lower pressure than the rainwater supply.
5. Occasionally toilet cisterns might make some strange noises due to some air coming through the pipes, this will do no harm, and is a normal part of the automatic operation.
6. The pump will attempt to re-start several times over the period of a few minutes. The pump might “crackle & gurgle” a bit due to air in it, as it tries to restart, this is not a fault, it is normal.
7. If the pump cannot get enough water it will then stay off for 24 hours, then repeat the same process every 24 hours to check if there is water in the tank.
8. If it happens to do this in the middle of the night it can be annoying! In the morning, turn it off & on again after 30 seconds and it will reset itself so it does the checking in daylight hours.
9. 6 to 8 are not applicable for a submersible pump with float switch, it will stay off until the tank fills again. If there is no rain for a long time, and the tank is dry, it is best to turn the pump off, at the power outlet.
10. Sometimes the pump may try to start when the tank is empty/nearly empty, this is not a warranty fault it is due to some water residue inside the pump. Simply turn the pump off at the power outlet until the tank refills with rainwater.
11. A “First-flush-diverter” or similar device must be installed to prevent debris from entering the tank, or a filter screen through which all the incoming water passes before entering the tank.
12. Sometimes even after rain, there might be an air-pocket in the pump and it does not restart. This is NOT a warranty fault!! Simply turn the pump off at the power outlet, and back on after 20 seconds, repeat until water flows normally. If this does not work, you may need to either: Turn the mains off using the MAINS ISOLATION VALVE (see front page) and restart the pump.
13. Before assuming there is a fault with the pump operation, check the water level in the tank, the pump may not operate unless there is 600 to 1200mm of water depth in the tank, note that tank-level indicators are not always reliable (water level required is dependant on the type of pump & the installation, also see the important note below)
14. **IMPORTANT! FOR PUMPS WITH FLOATS:** The water level will need to be 250mm to 800mm high inside the tank, for the pump to start.

INSTALLATION & CHECKLIST

- All installations must be in accordance with AS/NZS 3500.1
- Maximum Pressure - A pressure reduction valve must be fitted if mains supply exceeds 500kPa
- Maximum Temperature - for Coldwater use only.

INSTALLATION GUIDE: TICK AS COMPLETED AND LEAVE THIS FOR THE OWNER

* CONDITION OF WARRANTY: THIS CHECKLIST MUST BE COMPLETED AND LEFT FOR THE OWNER

STEP 1:

- Install Submersible pump into the tank using PVC or POLY 25mm (minimum ID size) outlet pipework attached. Do not use the electrical cable to lower the pump into the tank, use nylon rope or similar.

NO WARRANTY if the pipe is less than 25mm INTERNAL DIAMETER.

WARNING! Ensure a very strong connection of pipe to the Pump Outlet INSIDE the tank - use 15 wraps of threadseal tape on the MI fitting that attaches to the pump - if insufficient threadseal is used the pump may come loose and will then cycle on/off/on/off continually - this is not a warranty fault with the pump - it is the installers responsibility to rectify this if it occurs. Install the Valve-set external of the rainwater tank.

NOTE! DO NOT use COPPER or GALV PIPE directly connected to this pump, warranty void if used.

- IMPORTANT:** use a barrel union connection external of the tank, after an elbow to avoid the pump "start / stop twist" causing it to come undone, to allow easy removal of the pump for servicing, if the tank is installed under eaves or other structure such as a deck, ensure that the pump can be easily removed for servicing or repairs.
- IMPORTANT! Mandatory condition of Warranty:** you MUST install a "First-flush-diverter" or similar device to prevent debris from entering the tank, or a filter screen through which all the incoming water passes before entering the tank.

STEP 2:

- IF THE PUMP HAS A FLOAT SWITCH:** ensure it can move freely and wont get stuck against the side of the rainwater tank, or caught under struts or baffles inside the tank.

STEP 3:

- Attach Rainwater supply to the Valve, external of the tank, as shown in the diagram.

STEP 4:

- Connect Discharge pipework to the RM1500-2 Valve and connect to the house supply. It is recommended to use flexible, not rigid pipework, to help avoid vibrations from the pump transmitting to the house.

STEP 5:

- Mains supply is to be connected to the RM1500-2 valve assembly through the PRV (pressure Reduction Valve) ensuring that flow is with the direction indicated on the valves. DO NOT remove or adjust the PRV as it is integral to the function of the system - even if there is a PRV/PLV installed on the house supply already - do not remove this one - all warranty is voided if so and the system will not function correctly.

IMPORTANT:

1. Ensure mains is connected to the correct side, as labelled.
2. If installing close to a wall or other fixture, use barrel-union connections to allow removal if ever required.
3. MAXIMUM PRESSURE - A pressure reduction valve must be fitted if mains supply exceeds 500kPa

STEP 6:

- If garden use of rainwater is required, then this could be taken off between the pump and RM3550 valve assembly to avoid Townwater use on the garden - ensure compliance with Government, Local Government and Plumbing Regulations first.

Important! Work on the mains supply must be in accordance with the relevant plumbing code or standard, and performed by a licensed plumber.

STEP 7:

- After all pipe work is connected, check for leaks and rectify according to Plumbing regulations.

STEP 8:

- Plug the pump's power lead into the power outlet provided, which must be installed by a licensed Electrician according to Electrical Regulations.

IMPORTANT CONDITION OF WARRANTY

- 1. The power outlet used for the pump must be protected by an RCD (Safety Switch) - do not install the pumps without this protection. We recommend a separate circuit for the pump.
- 2. The Power Outlet must be in easy reach for the resident - it must not be up above the rainwater tank where a ladder is required to reach it.

STEP 9:

- Test the system by filling the tank with some town-water if it hasn't rained, then open connected garden taps, flush toilets etc. If the pump fails to operate, re-boot it and check if the float is in the UP position. Remember that pumps with a FLOAT SWITCH will need 250 to 800mm of water in the tank, to keep the pump on.

STEP 10:

- If you experience any problems, refer to the troubleshooting guide first, before calling for warranty service. A call-out fee will apply for all field service work if it is found not to be a Warranty problem.

INSTALLATION CHECKLIST: MUST BE FILLED IN FOR A WARRANTY TO APPLY

Installer name:.....Phone Number:..... Qualification:.....(write Owner if applicable)
 If installed by a Plumber or Electrician - Licence No:Installation Address:

Tick the boxes as the item is completed/correct, put n/a if not applicable

- Steps 1 to 10 have been completed
- The Pump is being used for an appropriate purpose for which it is intended, according to the instructions
- The Power Circuit the Pump is connected to is RCD (Safety Switch) Protected
- A mozzie screen and/or first flush diverter is installed to keep debris out of the tank
- All swarf has been removed from the tank after cutting openings etc.
- Barrel Unions are fitted on the external pipe connection for easy servicing and repairs
- Pipe is sized appropriately for the application (diameter and length)
- The installation is constructed so the pump can be easily removed for servicing
- The pump is installed in accordance with National and Local Plumbing Regulations
- The Electrical Supply cable of the pump is plugged into a Power Outlet that is in accordance with the current standard of Electrical Safety Regulations AS/NZS 3000 – or the pump has been wired directly to the power circuit by a Licenced Electrician, with an isolation switch incorporated.
- The Pump has been primed (filled with water) started, tested, and operates correctly.
- The pipes and connections and the barrel-union on the pump, and toilet cisterns (if connected) have been checked for leaks.
- The Owner has been shown how to check the tank water level, and re-set the pump (if owner/resident not in attendance this is not applicable.)

WARRANTY RECORD - FILL IN AND RETAIN THIS WITH YOUR ORIGINAL PURCHASE RECEIPT

PURCHASER NAME:		PHONE NO.		DATE OF PURCHASE.	
DEALER/STORE NAME		DEALER SUBURB/TOWN		PHONE NO..	
BRAND & MODEL NUMBER OF PUMP		SERIAL/BATCH NO.			
(Serial/Batch Number for External Pumps only – this is on the nameplate on top of the Electric Motor) Do NOT send this form to us, retain it for your record.					

THINGS TO CHECK BEFORE YOU CALL FOR SERVICE

WARNING! SAFETY FIRST – TAKE PRECAUTIONS! Before servicing a pump, always shut off the power supply and then make sure you are not standing in water and that there is no risk of electrical shock.

If the pump is direct-wired to the electrical circuit, contact a licensed electrician to disconnect it.

TROUBLESHOOTING CHECKLIST

Before you call for service or repair, please check the following common issues that sometimes cause the owner to wrongly assume there is a problem with the pump system. Unnecessary service calls must be paid by the owner, so check carefully.

PROBLEMS & POSSIBLE CAUSES:

1. **Pump Operates When Water Tank Is Empty:** this is either the normal re-start function of the pump, or due to an airlock, or some debris inside the pump > simple solution is to turn the power off to the pump, and turn it back on when rain fills the tank.
NOTICE: tank level indicators are not always accurate!! Check inside the tank to be sure of the water level.
2. **Pump does not run or motor runs for a short time, then stops**
 - i. Circuit breaker or Safety Switch is off or fuse has blown > in a SAFE manner investigate why this has occurred, by process of elimination > do not assume it is the pump > if you cannot do this safely, have a licenced Electrician check and rectify it.
 - ii. Water level in the tank is too low > Top up or use alternative supply > or turn pump off until the tank fills
 To be sure there is rainwater in the tank > tap the side of the tank, does it sound hollow? Feel the side of the tank, you can normally feel a temperature difference from where the water is to where there is none. If you cannot tell that way, get a torch and look in through the tank opening. The pump generally needs 250mm of water to work properly, pumps with FLOAT SWITCH will need 250 to 800mm depth of water. Be sure, if you call for service and tank is found to be empty, you will be liable for the cost of the service call.
 NOTE: Submersible Pumps with Float Switch may require up to 600mm of water level to operate.
 - iii. Electrical components have been flooded > in a SAFE manner investigate why this has occurred > do not assume it is the pump > if you cannot do this safely, have a licenced Electrician check and rectify it.
 - iv. Pump plug is not connected properly, or has been flooded or wet > Isolate power at main switch, remove plug & allow to dry. If the problem continues, contact a licenced electrician to check the cause.
 - v. Pump has an air-lock >Start and stop several times by turning the power off, wait 30 seconds, and turn on again, repeat if necessary. NOTE: you might need to turn the Townwater supply OFF to make it easier to re-start the pump.
 - vi. If all of the above are OK, the pump might have overheated and triggered the thermal overload switch > Turn it off and wait 30 minutes for it to cool down and turn it on again > If the pump does not operate normally, investigate why, it might be blocked with debris, > flush clean and re-assemble.
3. **Pump runs but does not deliver water or only a small amount of water**
 - i. Water filters on the discharge (if fitted) are clogged > check / clean /replace the cartridges
 - ii. Check valve is installed backwards, arrow on valve should point in direction of flow > have the installer fix this.
 - iii. Discharge shut-off valve/ball-valve / gate-valve may be closed > open the valve.
 - iv. Impeller or volute openings are fully or partially clogged or it might be blocked with debris > disconnect from the power supply, and if you are competent to do so, disassemble the pump and clean. If not, have a pump technician do it for you.
 - v. Pump is air-locked > Start and stop several times by turning it on and off with 20 seconds between. If this does not work, see below regarding re-priming the pump
 - vi. Vertical pumping distance is too high - Reduce distance or upgrade to a larger pump.
 - vii. Tank too low water level > Check the water level by looking inside the tank (Tank level indicators can be wrong)

4. Pump runs and does not stop or runs when no taps are in use – or cycles on/off/on/off continually

- i. In most cases this situation it is due to a leak in pipework or leaking toilet cisterns or an underground pipe leak (wet soil, muddy, grass growing well!) > it is not a pump fault > ascertain by process of elimination what is leaking > the quickest way to ascertain if it is in the house is usually by checking the water meter, follow this process;
 - a) Turn the pump off, and turn off the valve between the RM1500-2 Valves and the pump (Ball-valve or Gate-valve)
 - b) Then ensure all water outlets in the house and garden etc are turned off, ensure that any garden taps are off and not dripping.
 - c) Check the water meter, is it turning at all? It may be very slow, so leave everything off, and re-check in an hour
 - d) If there is movement in the water meter this would indicate a leak somewhere in the piping, or toilet cisterns, sometimes the toilet cisterns leak very slowly on the inside, but it can be enough to make the pump start & stop
 - e) Most toilets have a stop-cock under the cistern, so you can easily turn them off, and repeat the test, to see if it is the cistern that is at fault
 - f) If you perform all of the above and no leaks are evident in the plumbing system, it might be a fault with the pump, this is how to test that;
 - g) Turn off the isolation valve on the discharge pipework > does the pump stop = the leak is further down the pipe-line
 - h) If you have proved there is no leaks in the house, it could be some grit or particle is caught in the check-valve of the Pump – open all taps fully open and flush all toilets to try and flush the particles out, test again after doing this.
- ii. The pump has come loose off the pipe inside the tank > look inside the tank with a torch to check this > if the water is above the pump you will need to lower the water level so you can check this properly > if there is water leaking inside the tank have the original installer return and rectify this, it is not covered by the pump warranty as it is an installation issue.
- iii. There is a leak in the pipework inside the tank > reduce the water level in the tank until you can see the top of the pump, open a tap to a slow dribble so the pump starts, then remove the leaf-trap off the tank and use a bright torch to inspect the pipework inside the tank to see if it is leaking – even a slight leak will cause the pump to cycle on/off/on/off > if there is water leaking inside the tank have the original installer return and rectify this, it is not covered by the pump warranty as it is an installation issue.

5. Pump not pumping properly

- i. Too high head or pump under specified > Check specifications.
- ii. Too low water level > Check the water level in the tank, tank level indicators are not always accurate
- iii. If a check valve has been installed directly on the discharge of the pump, this will cause the pump controller to malfunction > Move the check valve to outside of the tank.

6. Safety Switch (RCD) or Circuit Breaker trips when the pump starts

- i. Circuit is overloaded with too many appliances connected to it > contact a licenced electrician to install additional circuit
- ii. Power plug is wet > refer 2.3
- iii. If none of the above, the Motor may be defective > have it checked by a qualified technician

7. Mains Water does not flow when power is off to the Pump

This is very unlikely due to the design of the RM1500-2 system, the possible cause for this problem would be a blockage in one of the valves, which is not a pump warranty > have the valves disassembled and cleaned by a licensed Plumber, or replaced.

8. Mains Water flows very slowly when power is off to the Pump

- i. The Town-water supply is usually less pressure than the pump supply. This is normal, it is not a fault. If the Town-water supply is very slow (a “dribble”) the possible cause for this would be a partial blockage in one of the valves, which is not a pump warranty > have the valves disassembled and cleaned by a licensed Plumber.
- ii. Filter between pump and house (if fitted) is blocked - change the filter cartridge.
- iii. Inlet filters on the inlet of the Toilet Cisterns and Washing Machine are blocked - turn the pump and the mains water off, disconnect the hoses and clean the filters.

9. Noisy Pump

When the water level in the tank is low, the pump will be noisier than when the tank is full, this is no cause for concern. Additionally, metal tanks exacerbate the noise and make it seem much worse.

The simple resolution is to turn the pump off at the power, until the tank refills with rainwater.

10. I have done all above, what do I do now?

If you have followed all the above instructions and continue to have a problem with your RM4000 / RM5000 / RC550 system & if you are sure the problem is a warranty problem please contact Ascento: Ph: 1800 807 604 or email: sales@ascento.com.au

We will need your proof-of-purchase and your name, phone number and address. It also is of great assistance if you can take a couple of photos of the system and email these to us with your details. Note that field-service staff can usually only access in the hours 9:00am to 3:30pm weekdays excluding public holidays. Please be aware that if our field service agent attends and finds it is not a warranty problem the applicable charges must be paid by you, at the time of the visit.

For pumps out of warranty please contact a local pump specialist – search internet for “Pump Repairs in my area”

Installation issues are covered by the Builders/installers warranty policy.

OPERATING & MAINTENANCE

- 1. OPERATING: No further action is needed once the system is installed; it will operate automatically
- 2. MAINTENANCE: Start by doing this MONTHLY: for submersible pumps – clean the inlet filter screen/first flush diverter according to manufacturers instructions. Ensure you re-fit the mesh strainer after doing this. If you find no debris, do it 2 monthly, review and repeat according to the conditions of your tank (installations where there is a lot of trees will need to be flushed frequently)
- 3. No other periodic maintenance is usually necessary, except if low flow rate is found when the MAINS supply is in use, ask a licensed Plumber to disassemble and clean blockages from the RM1500-2 valve assembly. This is not a warranty fault it is a maintenance item. NOTICE TO PLUMBER: avoid adjusting any of the Valves as they are factory set and must not be interfered with.
- 4. TROUBLESHOOTING: - Refer to the Troubleshooting Guide.
- 5. SPARE PARTS LIST IF REQUIRED:

RainPro RM5000-5 Water Controller Spare Parts		
Order Code	Description	Price inc. GST*
RM1500-2	RainPro RM5000-5 Valve Assembly	POA
8379	RainPro RM5000 Pressure Controller *External Pumps Only*	POA
Pump	As per the model supplied	POA

6. AFTER SALES SERVICE: Not normally necessary, however if you have any queries please call 1800 807 604

7. RECOMMENDED PRESSURES: A pressure reduction valve must be fitted if the mains supply exceeds 500kPa

OWNERS RECORD: FILL IN AND RETAIN THIS WITH YOUR ORIGINAL PURCHASE RECEIPT

PURCHASER NAME:		PHONE NO.		DATE OF PURCHASE.	
DEALER/STORE NAME		DEALER SUBURB/TOWN		PHONE NO..	
BRAND & MODEL NUMBER OF PUMP			SERIAL/BATCH NO.		
(Serial/Batch Number for External Pumps only – this is on the nameplate on top of the Electric Motor) Do NOT send this form to us, retain it for your record.					

RAIN TO MAINS SYSTEMS 2 YEAR WARRANTY CONDITIONS

- Our goods come with guarantees that cannot be excluded under the Australian Consumer Law. If you are a consumer as defined by the Australian Consumer Law, you are entitled to a replacement or refund for a major failure and for compensation for any other reasonably foreseeable loss or damage. You are also entitled to have the goods repaired or replaced if the goods fail to be of acceptable quality and the failure does not amount to a major failure. The following conditions form part of the instructions and do not over-ride your statutory rights.
- This warranty against defects covers failure due to manufacturing defects within the period as stated in the table below from the date of original purchase, for SUBMERSIBLE or EXTERNAL CONSTANT PRESSURE PUMPS and RAIN-TO-MAINS SYSTEMS, supplied by ASCENTO GROUP AUSTRALIA that are purchased and used in mainland Australia. In the case of a failure caused by a defect in the product, within the specified period from the date of original purchase, you can return it to the place of purchase for a refund or you can request for us to arrange for the pump to be repaired.
- Faults or losses or failure caused due to but not restricted to any of the following: improper use, improper installation, foreign objects inside the pump or pump controller, normal wear and tear, accidents, misuse, lack of maintenance, not following the installation instructions, damage caused by lightning strike, or power surges, or power spikes or power brownouts, or operating the pump on power other than correct mains power, or operating the pump on power supplied by a domestic generator, power supply of voltage less than 230V, power supply of voltage above 240V - are not covered by warranty. Improper use is defined by us, at our sole discretion.
- The complete Impeller set (including shaft), Seals and O-rings are all wearing items and therefore are not covered for "normal wear and tear". They are covered by this warranty if they fail due to a manufacturing defect. The Warranty also excludes accidental or deliberate breakages, fading or breakdown due to the effect of exposure to sunlight or chemicals or any other external factor that may affect the life of the product.
- Warranty will be void if any tampering or removal of identification labels or electrical cables has occurred, or any non-genuine parts have been fitted, or repairs have been carried out by unqualified persons. No warranty applies for goods sold or used for HIRE or RENT or LEASE. No warranty applies, and no liability is accepted, if the pump is used in circumstances that we define as: HAZARDOUS SITUATIONS, MINE SITE, REMOTE AREA, INDUSTRIAL APPLICATION, or any other UNSUITABLE APPLICATION, all of these circumstances are defined by us at our sole discretion.
- This product is guaranteed as fit for the purpose of pumping CLEAN FRESH WATER for normal domestic household use, and for NO OTHER USE. Performance data quoted is generally from test data and is approximate and does not take into account factors in the installation such as loss of pressure and flow due to pipework & pipe-fittings & valves. It is the purchaser's responsibility to ensure that the product is fit for their purpose and of sufficient size & performance for their application.
- IMPORTANT: No electrical appliances last forever. Therefore, ALL installations of these pumps and valve-sets supplied by us, must be constructed to allow the owner to easily remove them for servicing, and to easily remove them for replacement, warranty replacement or upgrading. The installation must NOT be constructed in such a manner that specialized tools, or paid tradespersons, or external paid contractors, are required to be engaged in order to remove and/or replace and/or refit the pump, therefore all pumps must be installed using barrel-union connections to facilitate easy servicing or replacement. If the rainwater tank is installed under eaves or other structure such as a deck, ensure that the pump can be easily removed for servicing or repairs. Warranty replacement does not normally include costs of removal and re-installation as we have no control over the method of installation.
- Before installing or servicing disconnect from the power supply. A ball-valve or gate-valve must be fitted on the suction, and the Town-water backup supply where fitted. A "First-flush-diverter" or similar device must be installed to prevent debris from entering the tank, or a filter screen through which all the incoming water passes before entering the tank. A Y-Strainer or Pre-filter must be installed: (a) For external pumps on the suction (inlet) pipe and (b) For submersible pumps on the discharge before the pump controller (for where there is an external pump controller) - to prevent particles entering the pump and fixtures and fittings including non-return valves. This instruction is a condition of warranty; all warranty is void if this instruction is not followed.
- This pump is not to be used as your sole water supply. For critical applications where loss of water supply could cause serious consequences, use a DUAL PUMP System so you have a backup water supply or use a TOWN-WATER BACK-UP System.
- This pump MUST NOT be installed in any manner that if it were to leak or fail to work that it would cause damage or loss to property or persons. It MUST be installed in a well-ventilated and drained area. All warranty is void if this condition is not heeded and no liability can be accepted in the case of damage or loss caused by failing to comply with this condition.
- The Pump must be connected to a suitable circuit with an integral RCD (safety switch) in the circuit breaker. All warranty is void if this instruction is not followed.
- RIGHT TO INSPECT: We reserve the right to inspect the product and installation, prior to accepting any warranty claim. We may inspect by use of drone technology, with property owners permission. We also reserve the right to request and require photographs or video evidence in lieu of physical inspection, at our sole discretion. Refusal of inspection cancels all warranty and liability.
- This warranty does not exclude any non-excludable rights according to Australian Law. However any condition that is made void by Australian Law does not void the remaining conditions, which shall stand unaltered.
- In the case of a fault, refer to the Trouble Shooting Guide first. If these steps do not rectify the problem, and the fault is due to a manufacturing defect or product failure not caused by improper installation, improper use or lack of maintenance, return the faulty appliance to the original place of purchase with proof of purchase for replacement or refund. Alternatively you can mail us at PO BOX 650 MORNINGSIDE QLD 4170 or send an email to csv@ascento.com.au with copy of your purchase receipt, a description of the problem, and your name and address and phone number - we will review your request and send you a replacement directly if we accept your warranty claim. Or call us on 1800 807 604 with the above information; however we will always require a copy of your purchase receipt. If an exact replacement is not available, the closest equivalent product will be supplied at our discretion. Do not send the product to us unless we ask you to do so.

WARNING! SAFETY FIRST – TAKE PRECAUTIONS!

*Before servicing a pump, always shut off the power supply and then make sure you are not standing in water and that there is no risk of electrical shock.

*If the pump is direct-wired to the electrical circuit, contact your qualified licensed electrician to disconnect if required.

***IMPORTANT NOTICE TO OWNER AND INSTALLER – SERVICER: Any replacement parts including the Backup Valves, Pump Controller and the Pump, MUST BE REPLACED WITH GENUINE PARTS or the system will malfunction.**

PRIVACY STATEMENT

We will not use your name, address, phone, or email address for marketing without your express permission. We will not sell or provide it to any other third party for the purpose of marketing.

ASCENTO GROUP AUSTRALIA 37 Export St, Lytton, Brisbane, QLD 4178 | P: 1800 807 604 • E: sales@ascento.com.au • W: www.ascento.com.au

© COPYRIGHT 2020 No part of this publication is to be copied stored or distributed in any manner or form without the prior written permission of Ascento Group Australia. E&EO.