

# ■ GEBERIT

## MECHANICAL UNDER COUNTER 150 CONCEALED CISTERN WITH FRAME

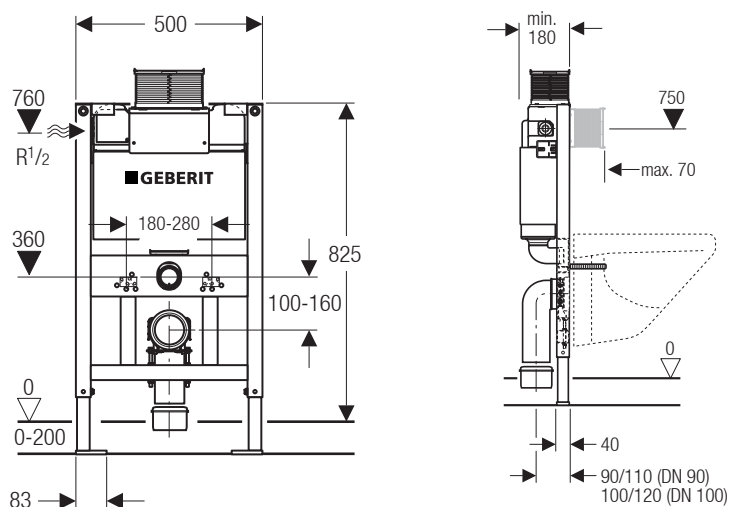

Product code: 9504011

### FEATURES

<b>15 year warranty</b>	On the tank
<b>One Piece tank</b>	High density, impact resistant blow moulded tank
<b>25 year spare parts availability guarantee</b>	Serviceable for the life of your bathroom
<b>Swiss know how</b>	130 year experience in every cistern
<b>Recommended use</b>	Domestic or Commercial

### SPECIFICATIONS

<b>Installation type</b>	Pre-Wall, Under Counter, Hob $\geq$ 210mm
<b>WELS rating</b>	4 Star
<b>Pan type</b>	Wall hung S or P Trap. Suits all major brands
<b>Flush volume</b>	4.5/3L adjustable to 6/3L
<b>Standards</b>	Watermark – AS1172.2
<b>Operating Pressure</b>	100-1000Kpa
<b>Operation</b>	Mechanical Top/Front press convertible to pneumatic*
<b>Load Rating</b>	400Kg

\* Separate service access required with pneumatic buttons

### BUTTON OPTIONS

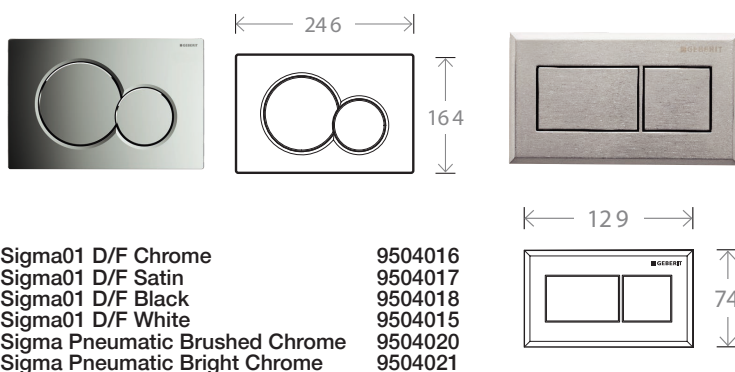

Sigma01 D/F Chrome	9504016
Sigma01 D/F Satin	9504017
Sigma01 D/F Black	9504018
Sigma01 D/F White	9504015
Sigma Pneumatic Brushed Chrome	9504020
Sigma Pneumatic Bright Chrome	9504021

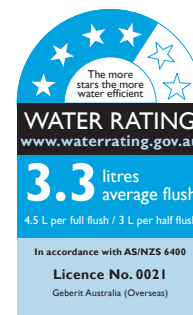

**Disclaimer:** Products in this specification manual must by regulation be installed by licensed and registered trade people. The manufacturer/distributor reserves the right to vary specifications or delete models from their range without prior notification. Dimensions and set-outs listed are correct at time of publication however the manufacturer/distributor takes no responsibility for printing errors.

Tech Page Version 1 – January 2013

# ■ GEBERIT MECHANICAL UNDER COUNTER 150 CONCEALED CISTERN WITH FRAME

## INSTALLATION INSTRUCTIONS

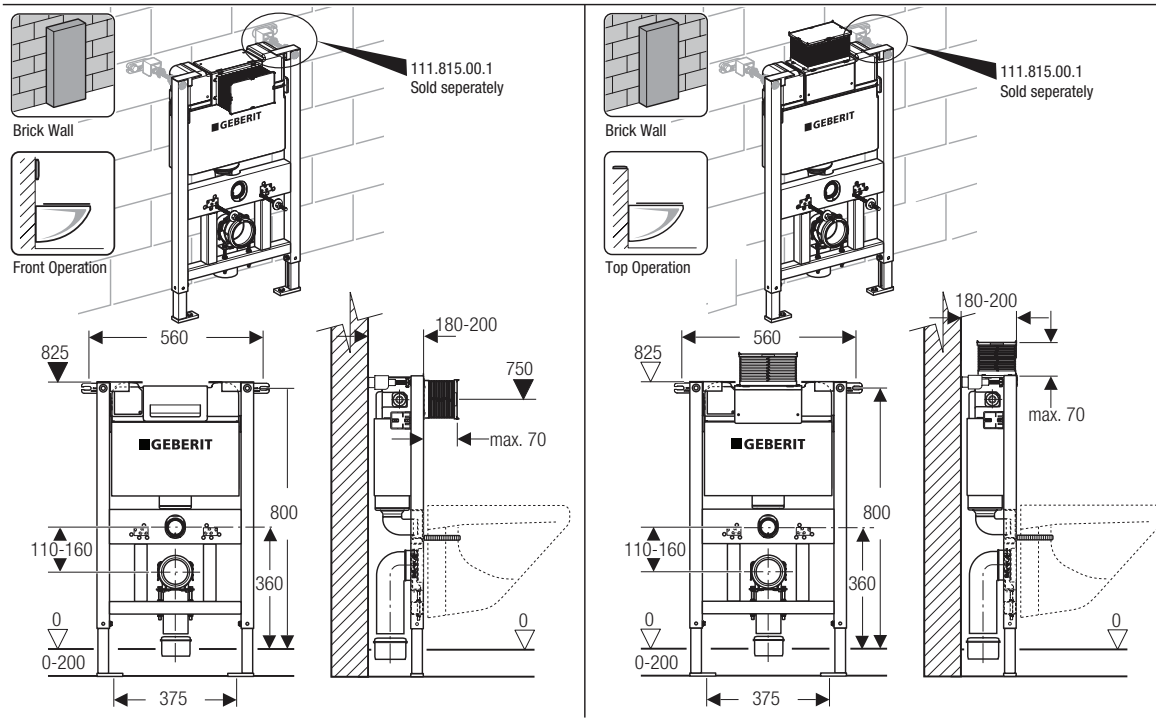
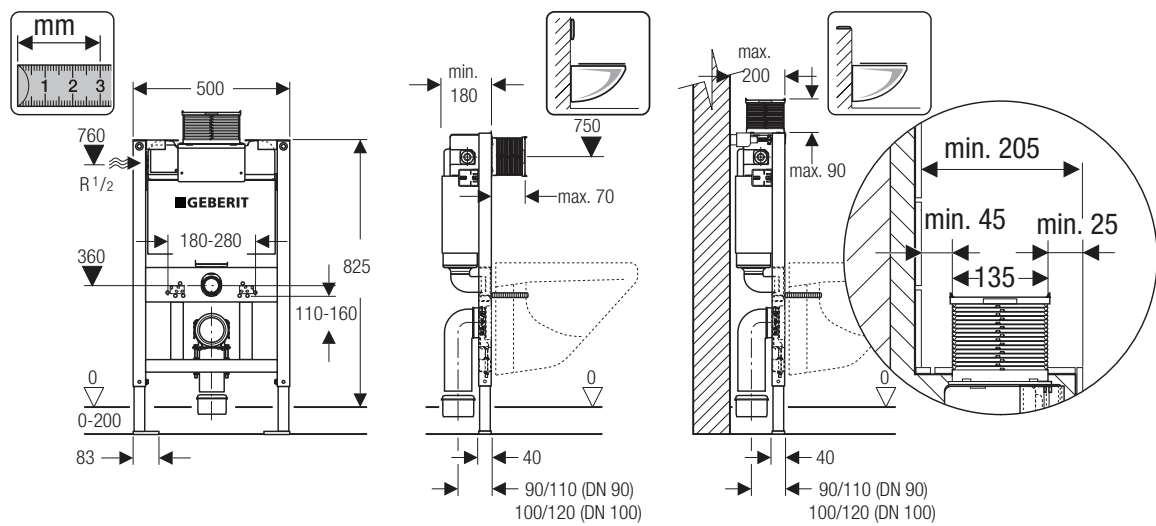

Plumbers, please ensure a copy of the installation instructions is left with the end user for future reference

**■ GEBERIT**

## MECHANICAL UNDER COUNTER 150 CONCEALED CISTERN WITH FRAME

### INSTALLATION INSTRUCTIONS

For S - Trap connection

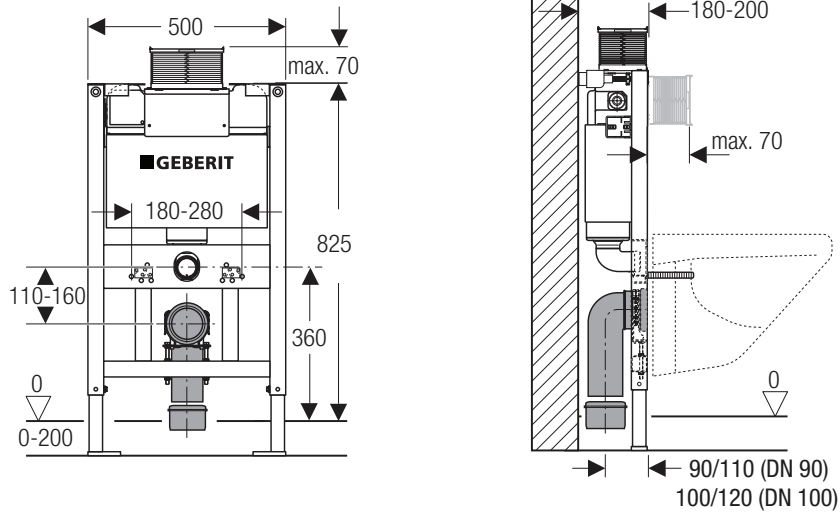

For P - Trap connection with fixation set Art. No. 111.815.00.1

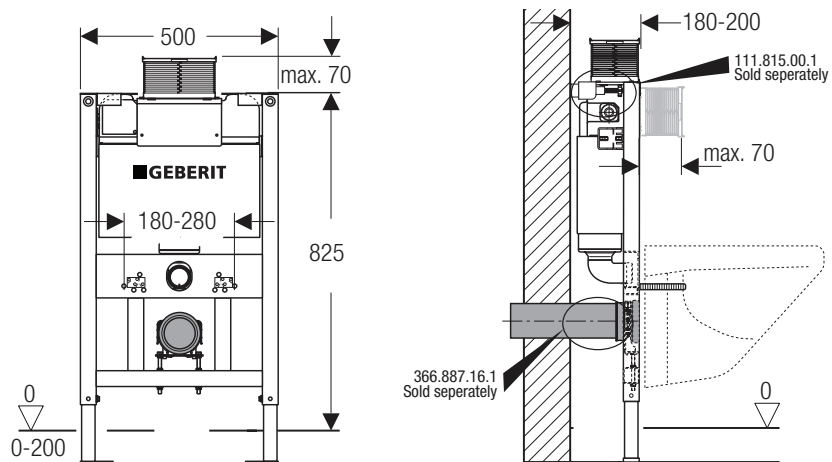

For P - Trap connection without fixation set Art. No. 111.815.00.1

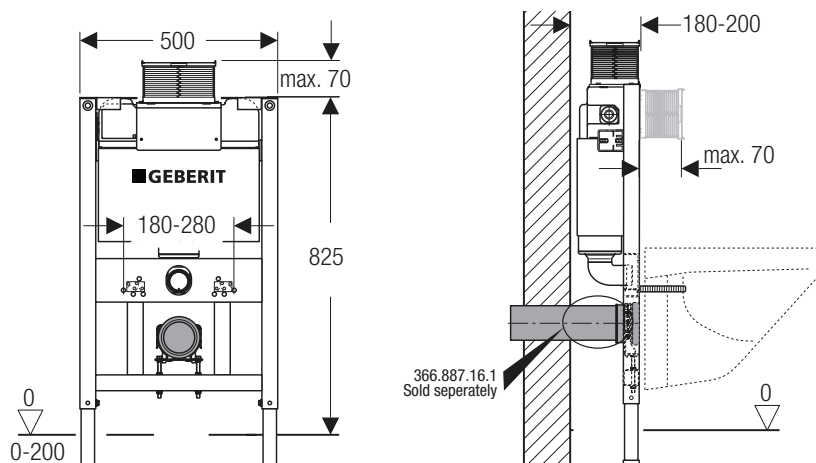

Plumbers, please ensure a copy of the installation instructions is left with the end user for future reference

**■ GEBERIT**

**reece**

**■ GEBERIT**

# MECHANICAL UNDER COUNTER 150 CONCEALED CISTERN WITH FRAME

## INSTALLATION INSTRUCTIONS

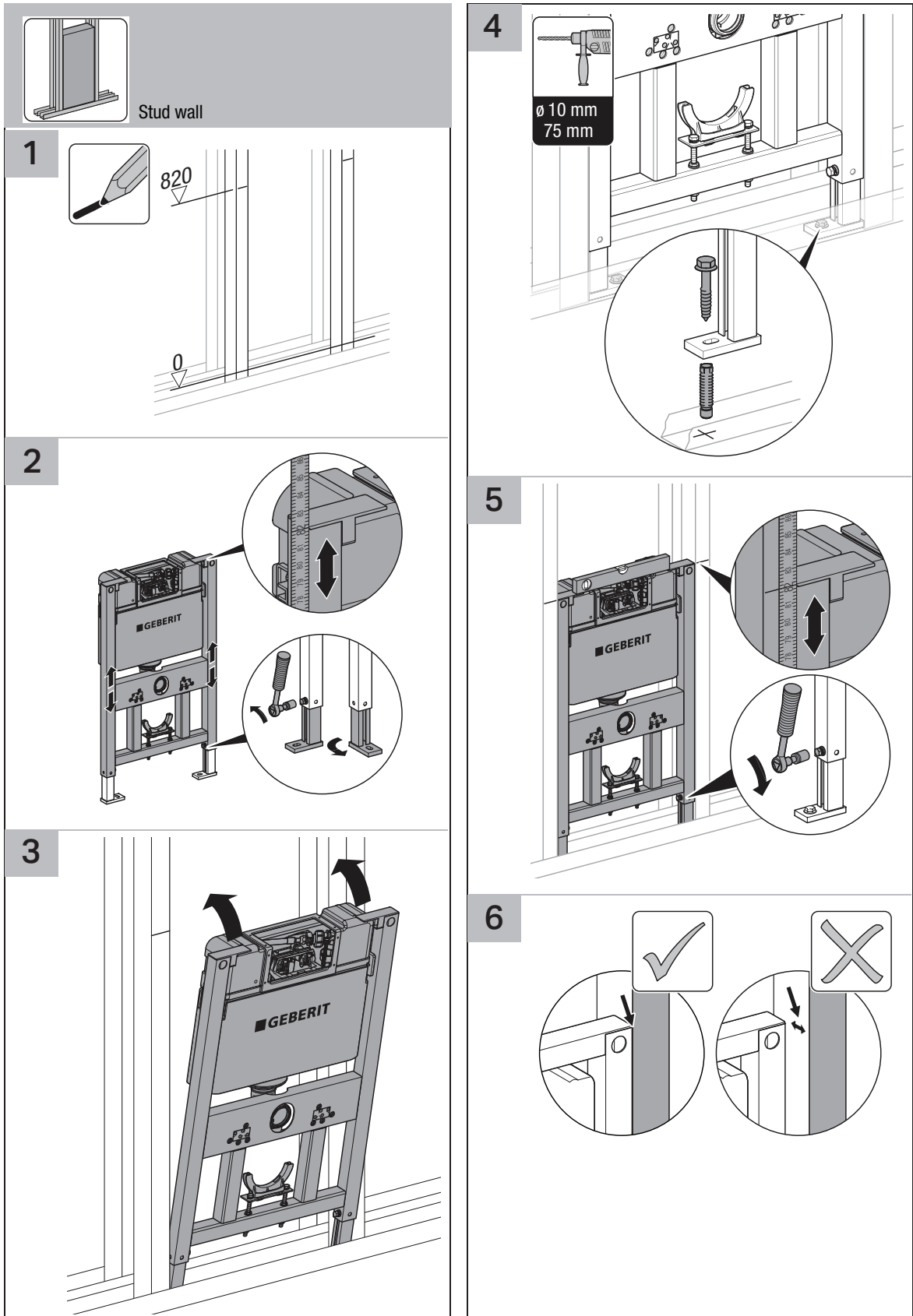

Plumbers, please ensure a copy of the installation instructions is left with the end user for future reference

**■ GEBERIT**

**reعه**

# ■ GEBERIT MECHANICAL UNDER COUNTER 150 CONCEALED CISTERN WITH FRAME

## INSTALLATION INSTRUCTIONS

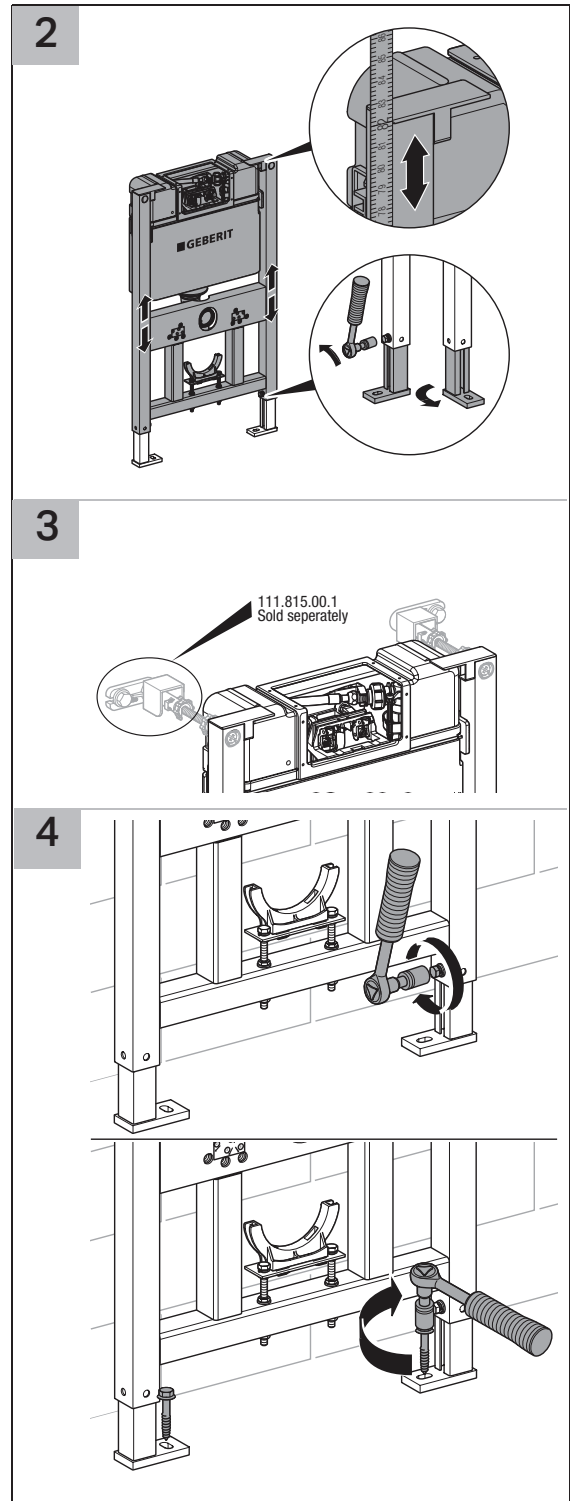
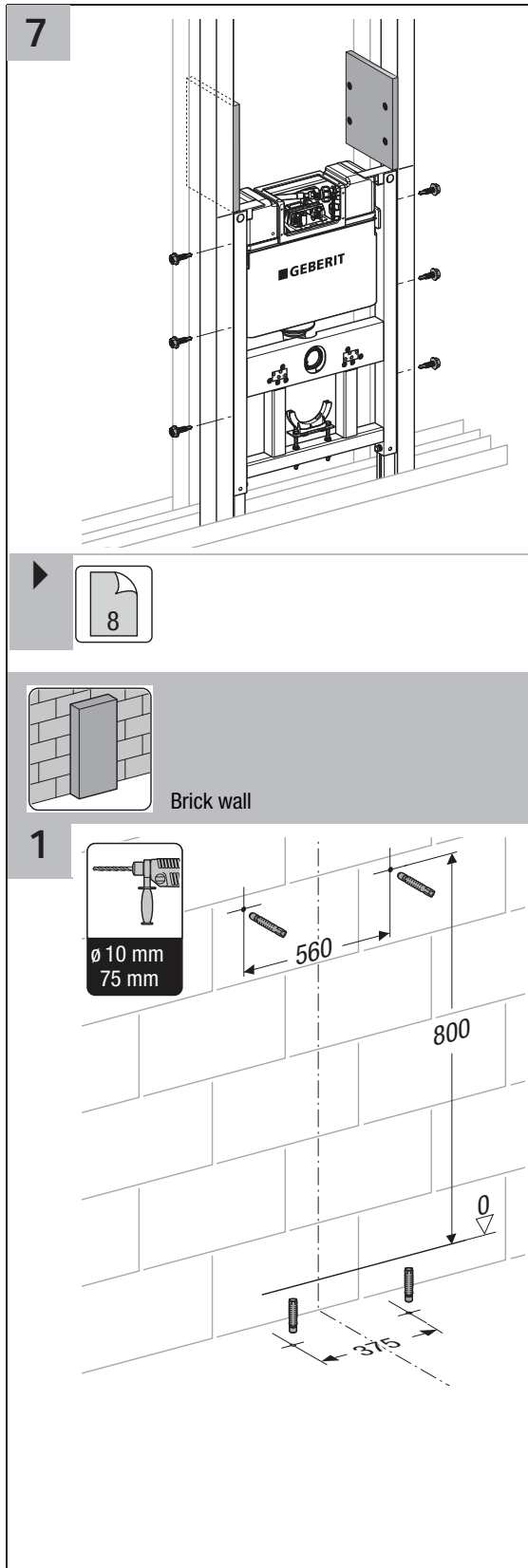

**MECHANICAL UNDER COUNTER 150  
CONCEALED CISTERN WITH FRAME**

**INSTALLATION INSTRUCTIONS**

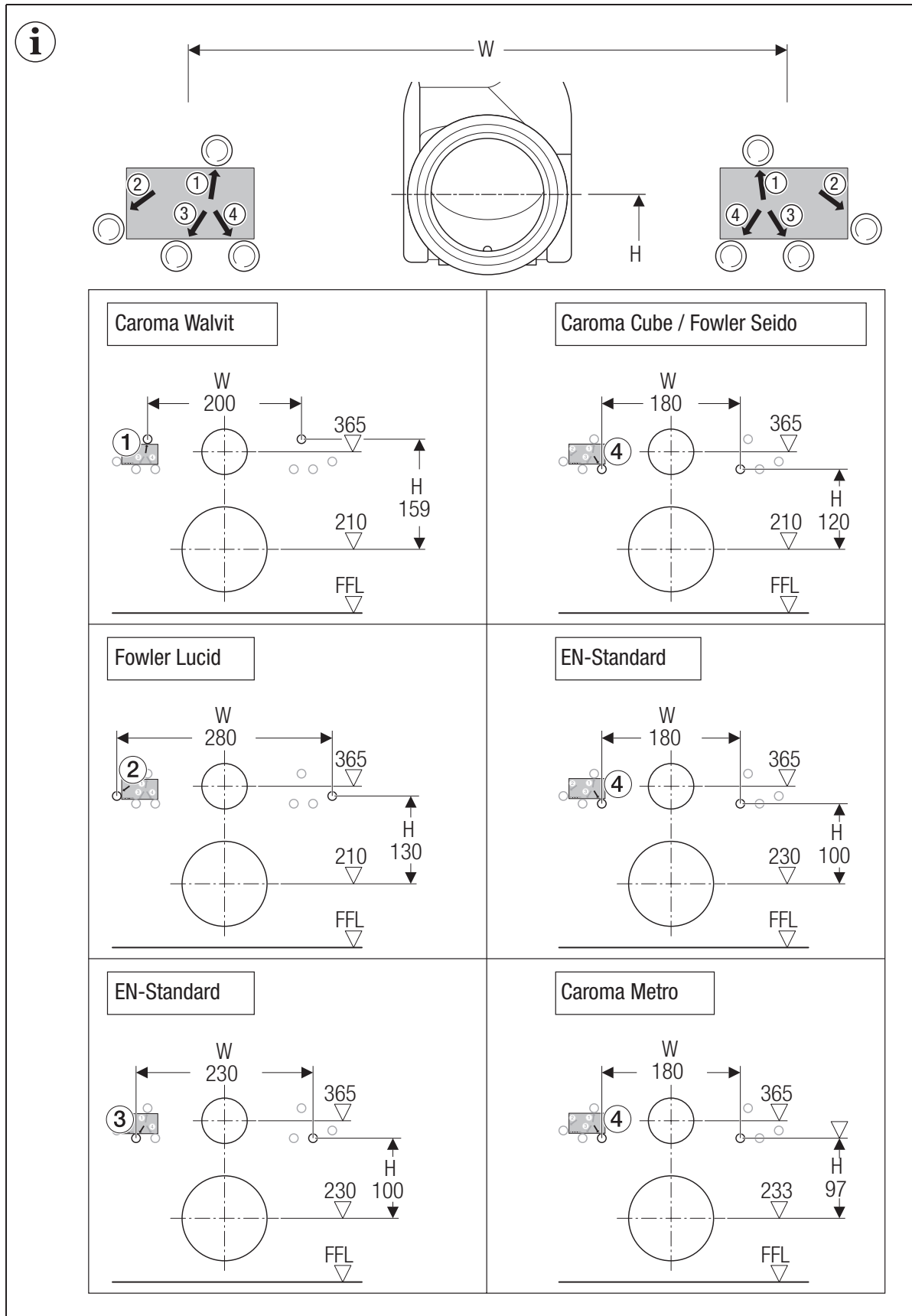

Plumbers, please ensure a copy of the installation instructions is left with the end user for future reference

**■ GEBERIT**

# MECHANICAL UNDER COUNTER 150 CONCEALED CISTERN WITH FRAME

## INSTALLATION INSTRUCTIONS

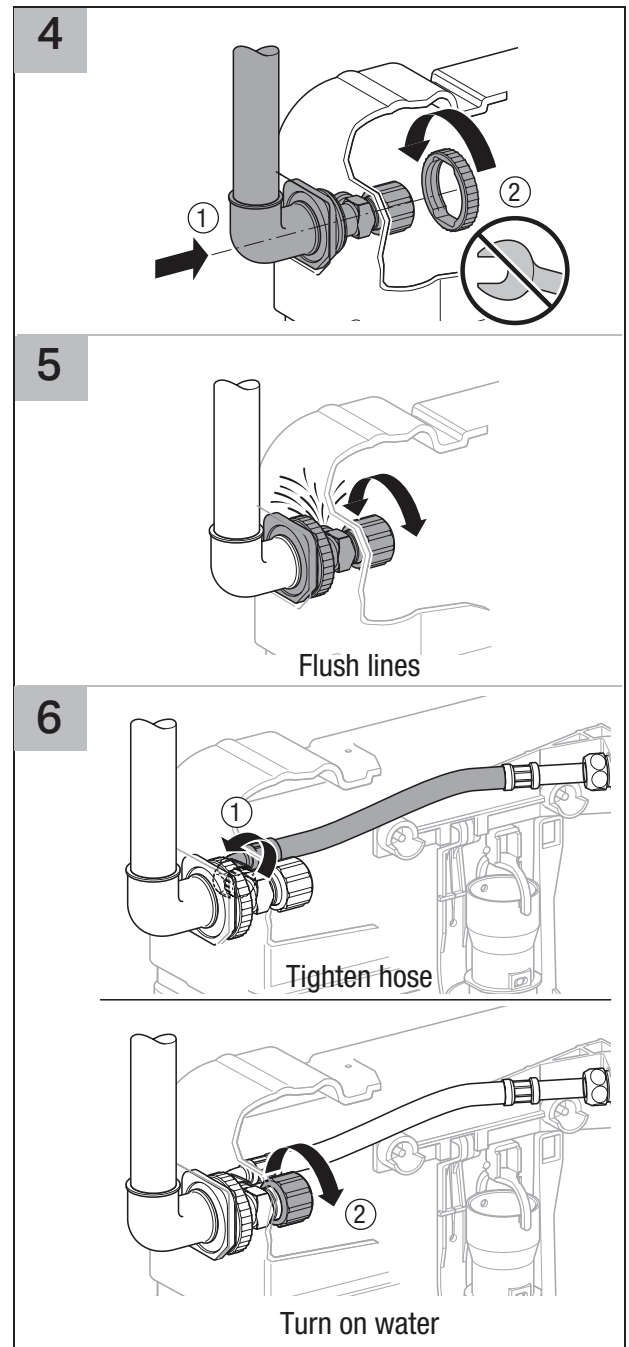
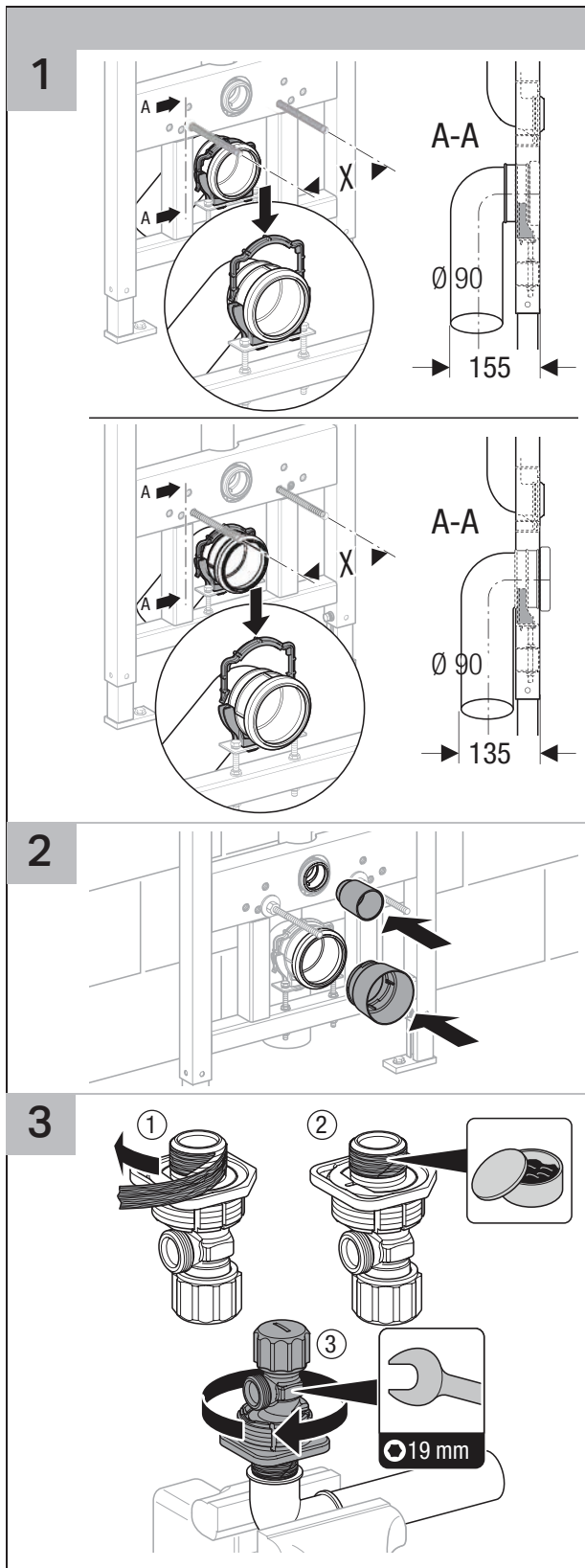

Plumbers, please ensure a copy of the installation instructions is left with the end user for future reference

**■ GEBERIT**

**reعه**

# ■ GEBERIT MECHANICAL UNDER COUNTER 150 CONCEALED CISTERN WITH FRAME

## INSTALLATION INSTRUCTIONS

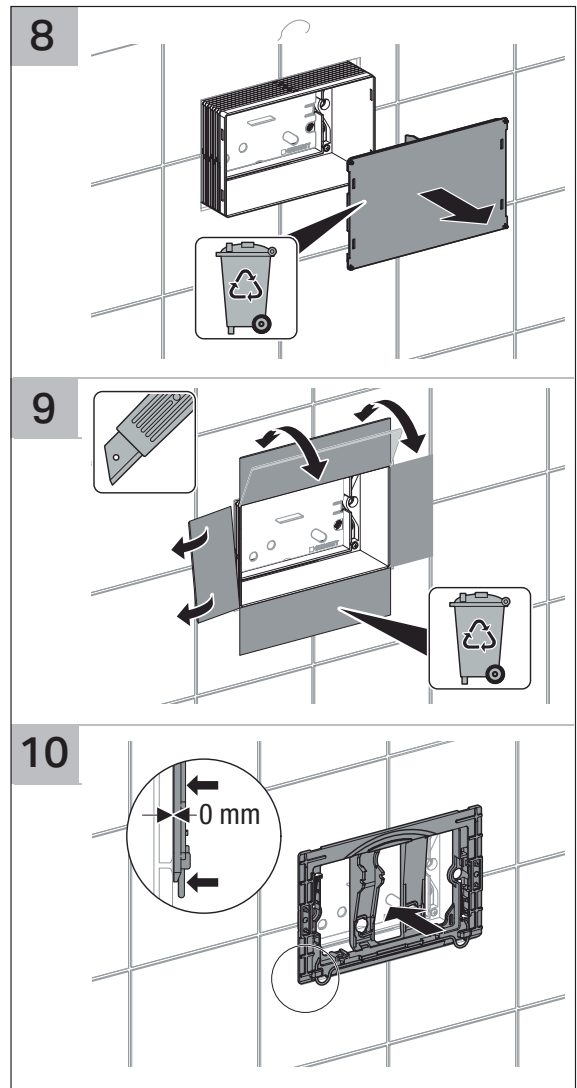
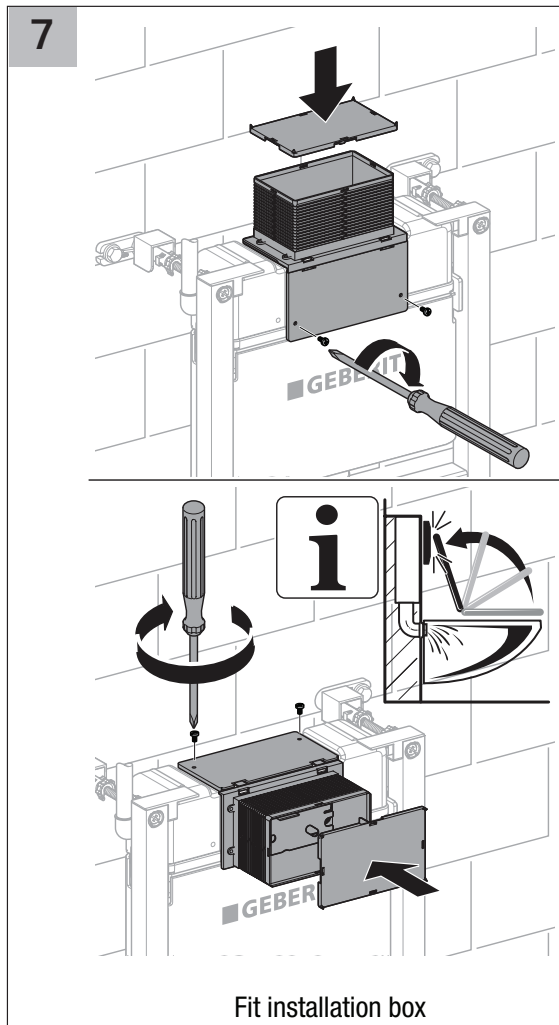



**■ GEBERIT**

## MECHANICAL UNDER COUNTER 150 CONCEALED CISTERN WITH FRAME

### INSTALLATION INSTRUCTIONS

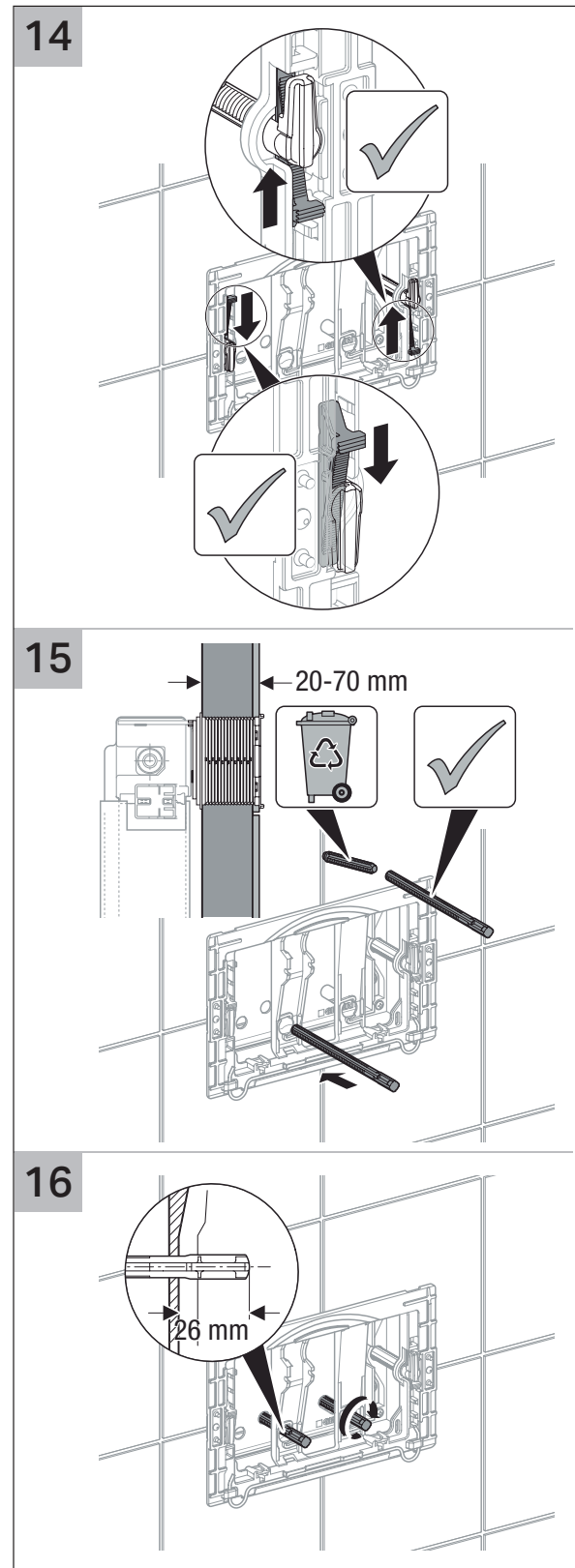
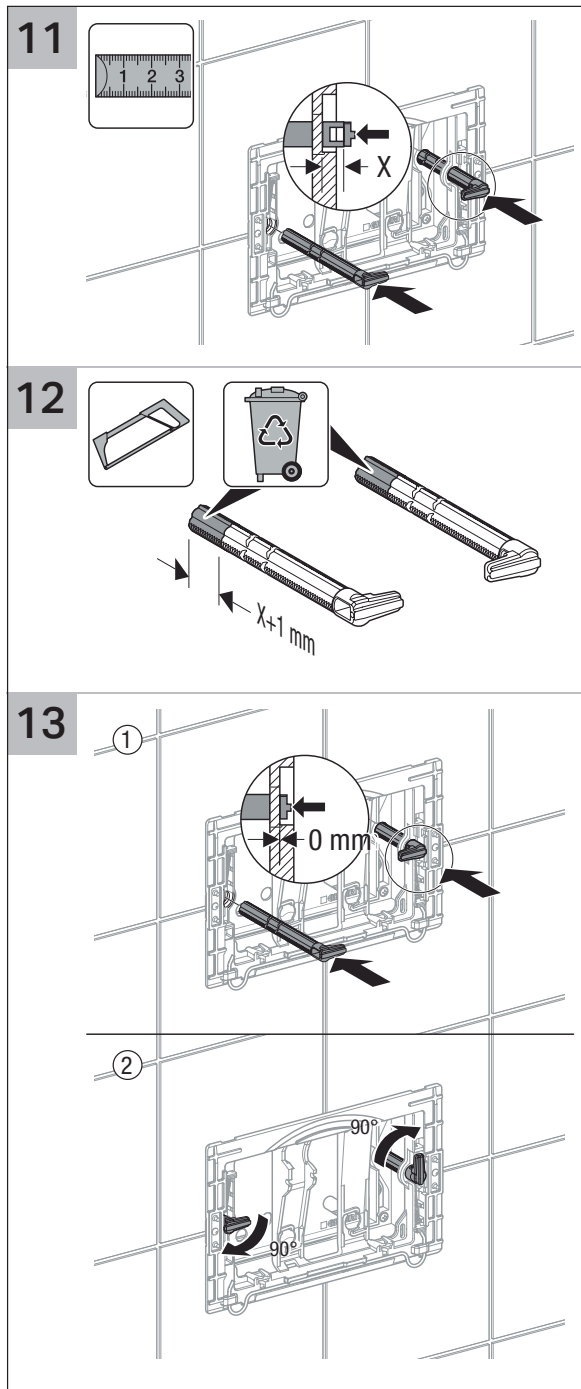

Plumbers, please ensure a copy of the installation instructions is left with the end user for future reference

**■ GEBERIT**

**reece**

**■ GEBERIT**

## MECHANICAL UNDER COUNTER 150 CONCEALED CISTERN WITH FRAME

### INSTALLATION INSTRUCTIONS

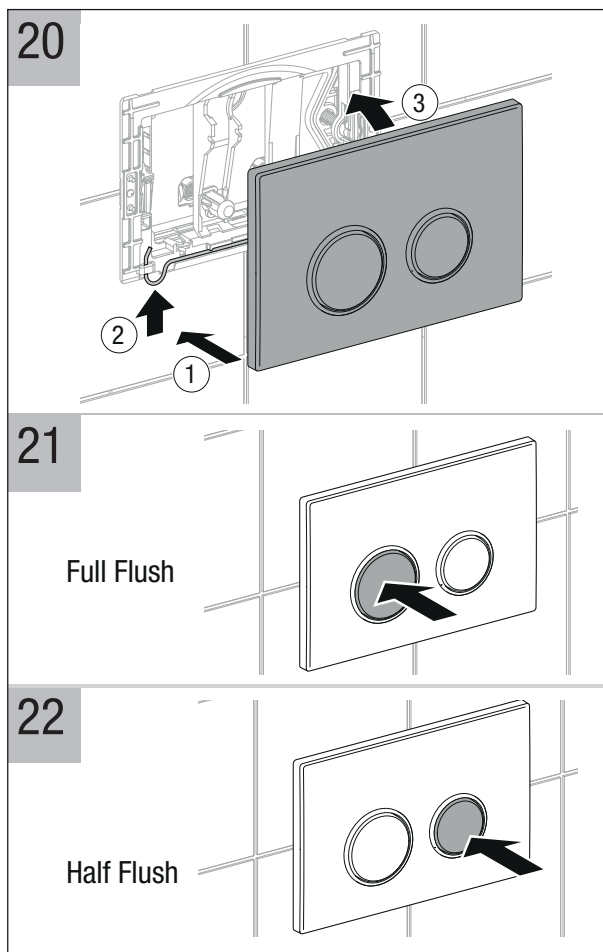
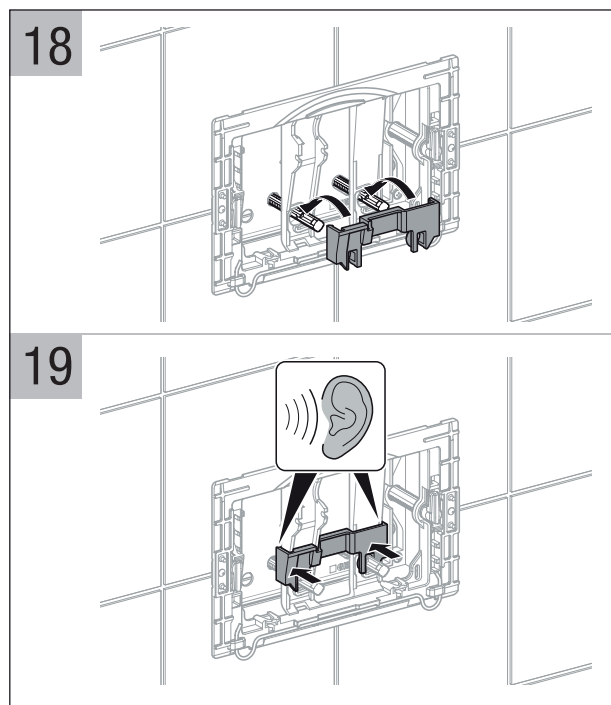

Plumbers, please ensure a copy of the installation instructions is left with the end user for future reference

**■ GEBERIT**

**reece**

## ■ GEBERIT

# MECHANICAL UNDER COUNTER 150 CONCEALED CISTERN WITH FRAME

### REECE PRODUCT QUALITY GUARANTEE

You have purchased a quality product from Reece Pty Ltd ABN 84 004 097 090 ("Reece"). This product is covered by a 15 year product warranty on the tank and push plate and a 3 year warranty on internal components including valves, electronic and pneumatic parts.

#### 15 YEAR WARRANTY – DOMESTIC USE

This warranty covers faults in the product construction, material and assembly. Products which are within 15 years from the date of purchase, found upon inspection by an authorised Reece representative, to be defective in construction, material or assembly, will be repaired or exchanged with an equivalent product free of charge. Replaced items become Reece's property.

All replacement products will be available for collection without charge to the customer at the nearest Reece branch to the customer's location, or elsewhere as agreed between the customer and Reece.

#### LABOUR

The labour for the replacement of products to which this warranty applies will be supplied by Reece or relevant supplier using licensed plumbers engaged by Reece or relevant supplier within 1 year from the date of purchase.

Spare parts which are within 1 year from the date of purchase found upon inspection by an authorised Reece representative to be defective in construction, material or assembly, will be replaced free of charge.

#### WARRANTY CONDITIONS

This warranty will apply only under all of the following conditions:

- The item has been installed by a licensed plumber
- The item has been installed for and subjected to domestic residential use only
- Failure is due to a fault in the manufacture of the product
- Proof of purchase (including the date of purchase) is provided
- The installation of the product is in accordance with the instructions provided

This warranty does not cover products purchased as an ex-display without being fully checked and tested for sale by the manufacturer.

This warranty does not include faults caused by:

- Unsuitable or improper use
- Incorrect installation or installation not in accordance with the instructions provided
- Installation or part installation by the purchaser or any person other than a LICENSED PLUMBER
- Normal wear and tear
- Inadequate or complete lack of maintenance
- Chemical, electrochemical or electrical influences
- Harsh detergents or abrasive cleaners used on product finishes

#### 1 YEAR WARRANTY – COMMERCIAL USE

'Commercial' use is all use other than for normal domestic residential purposes, including use in non-business places as in public buildings, schools, sports centres and in establishments that contain private bathrooms with high frequency of use by many individuals, such as hotels, motels, retirement villages and hospitals.

The Commercial warranty covers this product against manufacturing faults in the construction, material and assembly of both the finished products and any spare parts for a period of 1 year from the date of purchase. Products and spare parts which are found upon inspection by an authorised Reece representative to be defective in construction, material or assembly will be repaired or exchanged free of charge.

Replaced items become Reece's property. The labour for the replacement of products and spare parts to which this warranty applies will be supplied by Reece or relevant supplier using licensed plumbers engaged by Reece or relevant supplier.

The Warranty Conditions and exclusions which apply to the domestic use warranty also apply to this commercial warranty.

#### EXCLUSIONS

To the fullest extent permitted by law, Reece excludes all liability for damage or injury to any person, damage to any property, and any indirect consequential or other loss or damage.

#### CLAIM PROCEDURE

For all warranty queries customers are to contact the branch where the product was purchased. These details can be found on your purchase invoice. Our goods come with guarantees that cannot be excluded under the Australian Consumer Law. You are entitled to a replacement or refund for a major failure and for compensation for any other reasonably foreseeable loss or damage. You are also entitled to have the goods repaired or replaced if the goods fail to be of acceptable quality and the failure does not amount to a major failure.

### APPLICATION GUIDE – WALL HUNG

<b>CISTERN</b>	<b>Sigma75</b> 9504007 	<b>Sigma75 Pneumatic</b> 9504010 1800906 	<b>Sigma120</b> 9504013 	<b>Geberit 150 U/C</b> 9504011 
<b>OPERATION</b>	Mechanical	Pneumatic	Mechanical/Electronic/ Pneumatic	Mechanical/ Pneumatic
<b>BUTTON</b>	<b>Sigma01</b> 9504015 White 9504016 Chrome 9504017 Satin Chrome 9504018 Black 	<b>Sigma Pneumatic</b> 9504020 Satin 9504020 Chrome 	<b>Sigma80 Electronic</b> 9504022 Black Glass 9504023 Reflective Glass <b>Sigma01 Range</b> <b>Sigma Pneumatic Range*</b> 	<b>Sigma01 range</b> <b>Sigma Pneumatic*</b> 
<b>INSTALLATION TYPE</b>	In-Wall, Pre-Wall Service through the button	In-Duct In-Ceiling	In-Wall, Pre-Wall Service in the bathroom * Service access required	Under counter, Pre-Wall *Service access required

Don't risk it, use a licensed plumber.™

■ GEBERIT

reece™