



# Backflow Prevention

310 Series SCV & SDCV

100-200mm

## Installation, Testing & Maintenance

### INSTALLATION INSTRUCTIONS

**CAUTION:** Installation of Backflow Preventers must be performed by qualified, licenced personnel. It is the responsibility of the installer to ensure the correct device has been selected for the particular application. Faulty installation could result in an improperly functioning device.

ZURN WILKINS Model 310 Series Assemblies are for use on potable water lines where a potential hazard exists (Low Hazard) in the event of a backflow situation.

Damage to the device could result wherever water hammer and/or water thermal expansion could create excessive line pressure. Where this could occur, shock arrestors, check valves and/or pressure relief valves should be installed downstream of the device.

If installation is in a pit or vault, the Backflow Preventer must never be submerged in water because this could cause a cross-connection. Make sure that the pit or vault always remains dry by providing ample drainage.

1. Before installing a Model 310 Series Backflow Preventer, flush the line thoroughly to remove all debris, chips and other foreign matter. If required, a strainer should be placed upstream of the Backflow Preventer.

**CAUTION:** Do not use a strainer in seldom used emergency waterlines such as fire lines.

2. Provide adequate space around the installed unit so that the test cocks will be accessible for testing and servicing.
3. Install valve at least 305mm above surrounding flood level.
4. Always consult local codes for installation methods, approvals and guidance.

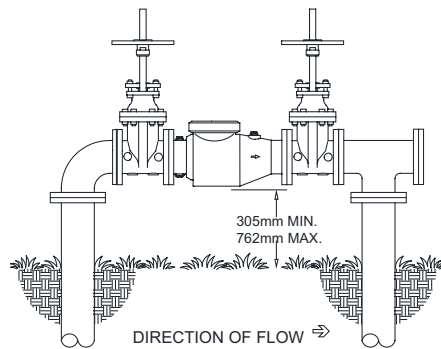

**OUTDOOR INSTALLATION**  
Model 310

### OUTDOOR INSTALLATION

The Model 310 Series Backflow Preventer may be installed outdoors only if the device is protected against freezing conditions. Exposure to freezing conditions will result in improper function or damage to the device. The installation location must be kept above 0°C. All the basic installation instructions apply.

### PLACING THE DEVICE IN SERVICE

1. Start with both shut-off valves closed. Slowly open the inlet shut-off valve until the Backflow Preventer is completely pressurised.
2. When the unit has been pressurised, vent any trapped air by slightly opening each of the two test cocks on the body, and the plug on the cover.
3. Slowly open the downstream shut-off valve. The Model 310 Series Assembly is now in service.
4. After the Model 310 Series has been properly installed, test the device (see "TEST PROCEDURES"). If the device fails the test, remove the check valve and thoroughly flush the device. Clean rubber and seats of all debris and place unit back in service.
5. If step 4 fails, repeat the step. If the device still fails, contact your local Reece branch for support.

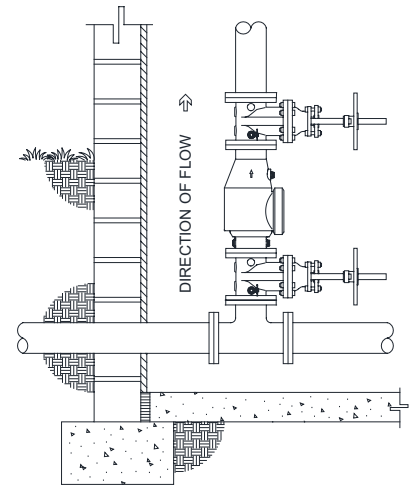

**VERTICAL INSTALLATION**  
Model 310

### INDOOR & VERTICAL INSTALLATION

Indoor installation is preferred in areas that are subject to freezing conditions. All the basic installation instructions apply to such installations.

Vertical installation is acceptable in applications where inlet and outlet piping are flowing vertically upwards. All the basic installation instructions apply to such installations.

# Testing Procedures

## MODEL 310 SERIES

Equipment Required: Differential pressure gauge test kit.  
(Backflow test kit)

\*\*\*Testing must be done in accordance with the latest version of AS/NZS 2845.3\*\*\*

The below instructions are specific to Zurn and act as a guide only.

### SCV

#### TEST

##### REQUIREMENT:

The static pressure drop across the valve shall be at least 7 kPa. If this is not reached, repair and clean the valve then test again. If it still fails, contact your local Reece branch for assistance.

##### PROCEDURE:

1. Slowly open the 2 test cocks to remove any foreign material and attach fittings. Close before continuing.
2. Attach hose from the high side of the test kit to the #1 test cock.
3. Attach hose from the low side of the test kit to the #2 test cock.
4. Open test cock #1 and bleed out all content by opening the high side bleed needle valve. Close the needle valve before continuing.
5. Open test cock #2 and bleed out all content by opening the low side bleed needle valve. Close the needle valve before continuing.
6. Record the static pressure drop across the valve after gauge reading stabilises.
7. Close all test cocks and remove test equipment.

### SDCV

#### TEST i- Main Valve

##### REQUIREMENT:

The static pressure drop across the valve shall be at least 7 kPa and at least 10kPa higher than the actual reading of the pressure drop measured across the bypass for test ii. If this is not reached, repair and clean the valve then test again. If it still fails, contact your local Reece branch for assistance.

##### PROCEDURE:

8. Slowly open 2 test cocks to remove any foreign material and attach fittings. Close before continuing.
9. Attach hose from the high side of the test kit to the #1 test cock.
10. Attach hose from the low side of the test kit to the #2 test cock.

Please note all installation and testing procedures listed are intended as a guide only. Installation and testing must be in accordance to local standards and plumbing codes.

11. Open test cock #1 and bleed out all content by opening the high side bleed needle valve. Close the needle valve before continuing.
12. Open test cock #2 and bleed out all content by opening the low side bleed needle valve. Close the needle valve before continuing.
13. Record the static pressure drop across the valve after gauge reading stabilises.
14. Close all test cocks and remove test equipment.

#### TEST ii - Bypass

##### REQUIREMENT:

The static pressure drop across the valve shall be at least 7 kPa. If this is not reached, repair and clean the valve then test again. If it still fails, contact your local Reece branch for assistance.

##### PROCEDURE:

1. Close isolating valves on bypass valve.
2. Slowly open upstream (inlet) test cock on bypass to remove any foreign material and attach fittings. Close before continuing.
3. Attach hose from the high side of the test kit to upstream (inlet) test cock of the bypass.
4. Attach hose from the low side of the test kit to test cock #2 of main valve.
5. Open both test cocks and bleed out all content by opening the high side bleed needle valve. Close the needle valve before continuing.
6. Slowly open low side bleed needle valve. Close needle valve before continuing.
7. Record the static pressure drop across the valve after gauge reading stabilises.
8. Close all test cocks and remove test equipment.

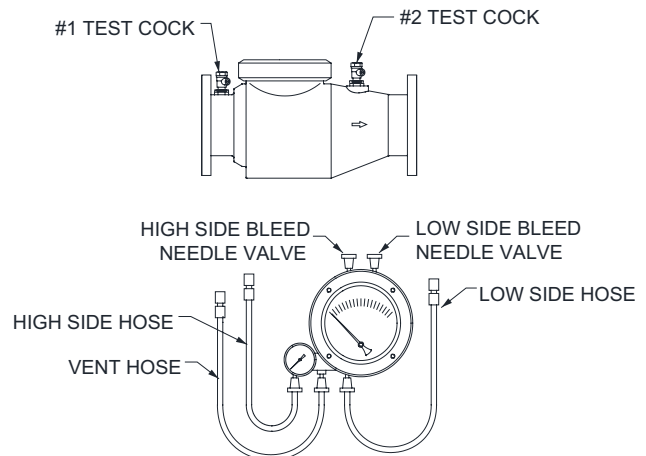

## Repair Kits

SIZE	MODEL 310 RUBBER ONLY (ZURN CODES & REECE CODES)
100mm	RK4-310 (180469)
150mm	RK6-310 (180465)
250mm	RK8-310 (4000415)

# Maintenance Instructions

## CHECK ASSEMBLY

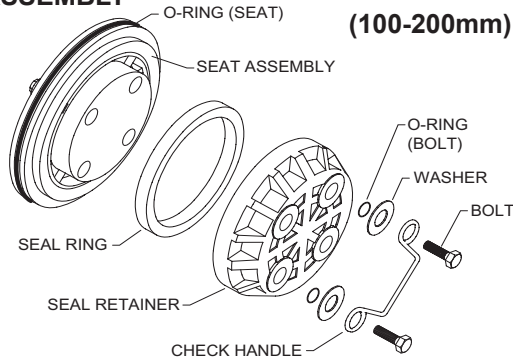

All Model 310 Series Backflow Preventers must be inspected and maintained by an accredited backflow prevention tester at least once a year or more frequently as specified by local codes. Replacement of worn or damaged parts must only be made with genuine "ZURN WILKINS" parts.

### GENERAL MAINTENANCE

1. Clean all parts thoroughly with water after disassembly.
2. Carefully inspect rubber seal rings and O-rings for damage.
3. Test unit after reassembly for proper operation (refer to "TESTING PROCEDURES").

NOTE: If any portion of the seat assembly is damaged or missing or if the seating surface is damaged in any way, do not attempt to field repair it. Contact your local Reece branch for assistance.

## SERVICING CHECK VALVES

1. Close inlet and outlet shut-off valves.
2. Loosen and remove the two nuts, bolts and gasket from the grooved coupling around the access cover. Remove access cover.
3. The valve has a plastic retainer securing the check, grasp one of the exposed ends, push down and then pull. The retainer should "spiral" out of the groove around the check.
4. Remove the hardware and O-rings from the back of the check assembly (See "Check Assembly" illustration). Separate the seal retainer from the assembly to expose the seal ring.
5. Inspect the seal ring for cuts or embedded debris and replace if cut or damaged in any way. If the reverse side of the seal is unused, the seal ring can be inverted and used temporarily until a new seal is obtained.
6. Inspect valve cavity and seating areas. Flush with water to remove any debris.
7. To reassemble, lubricate the O-ring and reinstall check in the body.
8. Install the plastic retainer by inserting one end into the body groove and then sliding your hand around the face of the retainer, pushing it into the groove as you go. The retainer will "snap" into place when fully seated..
9. Install the access cover and grooved coupling, lubricate the outside surface of the coupling gasket, making sure the ends of the coupling touch each other. Tighten coupling nuts to proper torque and place valve back in service.

## Troubleshooting

### PROBLEM

1. LEAKING CHECK VALVES

### POSSIBLE CAUSES

1. Debris on seat or seal ring
2. Damaged seat area
3. Damaged seat o-ring
4. Damaged bolt o-ring (s) on check retainer

### CORRECTIVE ACTION

1. Clean seat area
2. Replace check assembly
2. Replace seat O-ring
4. Replace O-ring (s)

2. LOW OR NO FLOW

1. Device installed backwards
2. Isolation valves not fully open
3. Low supply pressure

1. Verify flow direction arrow
2. Turn handles counterclockwise

3. Attach pressure gauge to test cock #1 and verify pressure

## Performance Characteristics

MODEL 310 100mm, 150mm & 200mm (STANDARD & METRIC)

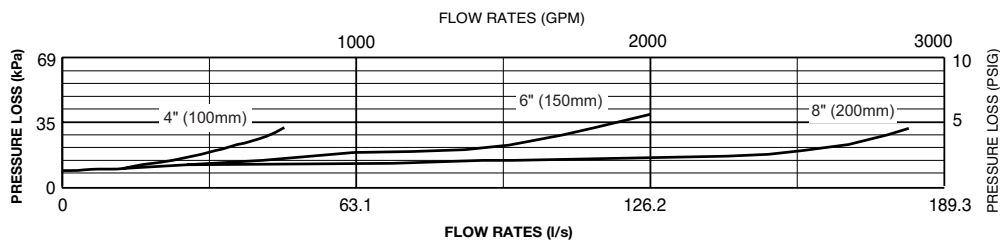

### Capacity through Schedule 40 Pipe (l/s)

Pipe size (mm)	1.5 (m/s)	2.3 (m/s)	3 (m/s)	4.6 (m/s)
100	12.5	18.8	25.0	37.5
150	28.4	42.6	56.8	85.2
200	49.2	73.8	98.4	147.6

### SPECIFICATIONS

Maximum working water pressure:	1200 kPa
Maximum working water temperature:	60°C
Hydrostatic test pressure:	2400 kPa
End connections:	Flanged AS 2129 TABLE E Grooved, AWWA C606

Proper performance is dependent upon licenced, qualified personnel performing regular, periodic testing according to ZURN WILKINS' specifications and prevailing governmental and industry standards and codes and upon following these installation instructions. Failure to do so releases ZURN WILKINS of any liability that it might otherwise have with respect to that device. Such failure could also result in an improperly functioning device.

Zurn Industries, LLC | Wilkins  
1747 Commerce Way, Paso Robles, CA U.S.A. 93446 Ph. 855-663-9876

In Australia | Reece Group  
57 Balmain Street, Cremorne, VIC 3121, Ph. 1800 080 055

[zurn.com.au](http://zurn.com.au) | [reece.com.au](http://reece.com.au)