

# INSTALLATION GUIDE

## Milli Pure Progressive Hob Mixer

**Fig.1**

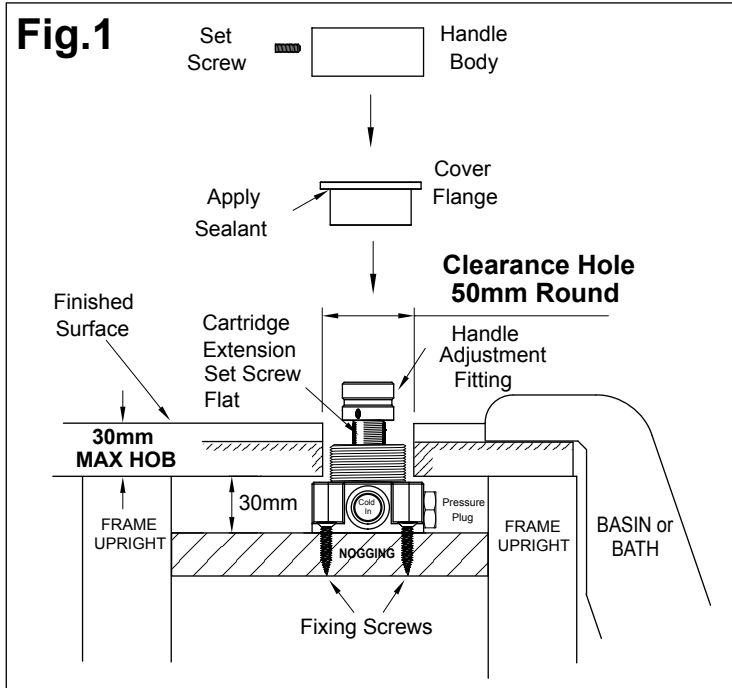

**Fig.2**

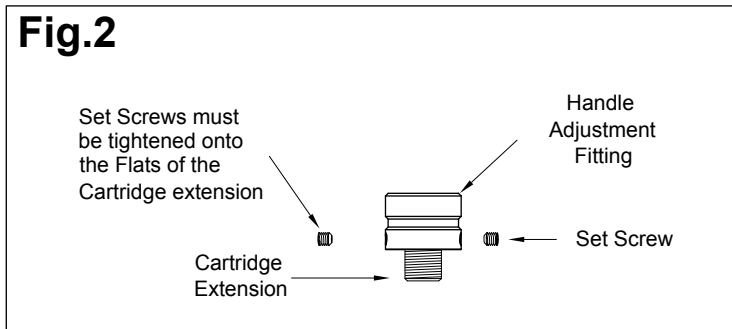

**Fig.3**

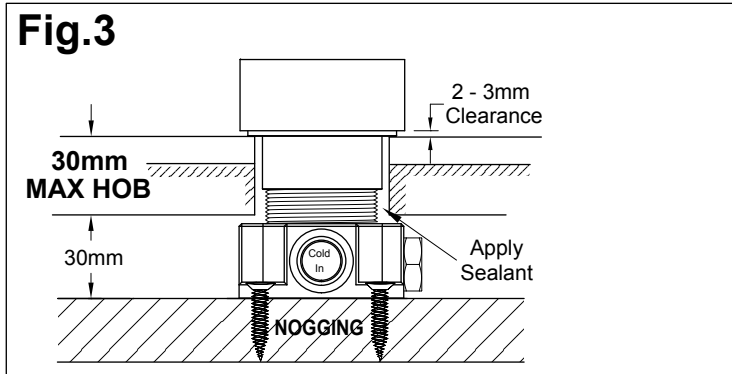

### DRESS FINISHING AND HANDLE ADJUSTMENT

Prior to fit off ensure the correct size cut out around the Mixer has been achieved.(See Fig.1)

**Important**, the Hob must be completely water tight, apply sealant around the Mixer. (See Fig.3)

Sussex Taps will take no responsibility for water leaking under the Hob surface.

Apply sealant to the Cover Flange (See Fig.1) and fit to the Mixer, ensure the shoulder meets the Finished Surface.

Fit the Handle onto the Adjustment Fitting.

If adjustment is required, remove the Handle and loosen the Set Screws of the Adjustment Fitting.(See Fig.1)

Wind the Adjustment Fitting to reduce or increase the gap between the Wall and the Handle.

The gap from the Finished Surface to the Handle is between 2-3mm. (See Fig.3)

To adjust, remove the Handle and loosen the Set Screws of the Adjustment Fitting.

Rotate the Adjustment Fitting to gain the correct height of the Handle. (See Fig.3)

When adjusting the Handle gap, ensure the Set Screws are tightened onto the flats of the Cartridge Extension. (See Fig.1)

Do not tighten the Set Screws on the threads of the Cartridge Extension.

Fit the Handle so the Set Screw is positioned to the rear.(Tighten well)

Note, the Set Screw must engage in the groove of the Adjustment Fitting.

Tapware is to be installed by a Licenced Plumber in accordance with AS/NZS 3500:2003

Recommended working water pressure 300 - 500 Kpa.  
Maximum water temperature is 65 deg.C.

Clearance Hole size 50mm  
Maximum Hob thickness for standard Mixer

### ROUGH IN PLUMBING

Prior to installing, ensure that the finished Hob thickness (including Tile) doesn't exceed 30mm (See Fig.1)

The Mixer is supplied with a plastic cover to protect the Mixer during Tiling.

A Pressure plug is used to seal one outlet port (Do Not Remove)  
The Hot/Cold Ports are marked on the shoulder of the Mixer along with Red/Blue thread plugs.

The Outlet Port is marked "OUTLET"

Set a Nogging 30mm down from the top of the upright frame as shown (See Fig.1).

Ensure the Nogging is level and well secured.

Using the screws provided, fix the Mixer to the Nogging.

Flush all water feed lines. Pipes and fittings must be free from any dirt and debris before connecting to the Mixer.

Once all water fittings are connected, check Hot/Cold water flow by operating the Mixer.

Check for any water leaks.

Once all checks have been made, leave the Mixer in the closed position and replace the protective cover.

Store remaining parts in a safe place until final fit-off is required (Dress finishing).

### Plumber please note:

On-site high pressure line testing must be conducted with the Mixer in the closed position. (STATIC TEST ONLY)

Under no circumstances is the Mixer to be opened when exceeding the maximum stated water pressure.

At the completion of the testing, do not relieve any high pressure by opening the Mixer.

Exposing the internals of the Mixer Cartridge to higher than specified water pressures, will void the manufacturer's warranty.

Contact manufacturer for possible options if the installation is not achieved as shown in Fig.3