



Milli Pure Wall Top Assemblies

Tapware is to be installed by a Licenced Plumber in accordance with AS/NZS 3500:2003

Recommended working water pressure 300 - 500 Kpa.
Maximum water temperature is 65 deg.C.

ROUGH IN (NEW WALL BREECH)

- A standard Plumbing Wall Breech (not supplied) is to be used in conjunction with this Tapware.
- Secure a nogging 35 - 40mm back from the front of the stud. (See Fig.1)
- Attach the Wall Breech to the nogging.
- Ensure the Breech Tap Seat Bodies are square and parallel between the Wall Studs.
- To allow the Tapware to fit correctly the thickness of the finished Wall coverings must be calculated prior to "Rough in".
- The Tap Seat Body of the Breech should be 10 to 20mm back from the finished wall coverings. (See Fig.1)

USING EXISTING BREECH (CHANGING TAPWARE ONLY)

- Remove the old Spindles and clean surrounding area.
- Use a re-seating tool to dress the Seat.
- Ensure the Spindle Seat is clean, flat and free of any debris.
- Water inlet lines must be completely flushed prior to fitting the Spindles.
- The distance from the Finished Wall Surface to the top of the Tap Seat must be between 10 to 20mm (See Fig.1)
- If the Tap Seat body is not within the dimensions shown in Fig.1. Alternative Spindles may be required.

Longer Spindles can be ordered from original place of purchase.

**NOTE: Seat or Breech Body extensions are NOT to be used in conjunction with this Tapware.
Failure to adhere will void warranty.**

FITTING OFF

- Carefully unpack the Tapware; note some parts have been combined for packaging purposes.
- Separate all parts as shown in Fig.1
- Install the Spindles hand-tight until the seal of the Spindle firmly makes contact with the seat.
- Using an appropriate spanner tighten the Spindle another 1/8th of a turn. Do not over-tighten.
- Note, over-tightening the Spindles could damage the ceramic discs and in turn, void the manufacturer's warranty.
- Place the Fibre washer over the seated Spindle and fit the Spindle Locknut. (Tighten well). (Fig.1).
- Seal the wall around the Spindle and fit the Spindle Locking Flange to meet the Finished Wall Surface. (Fig.2)
- Screw "Cut-off" Gauge to the remaining threads of the Locknut (See Fig.3)
- Using an appropriate saw, cut off the remaining thread against the "Cut-off" Gauge. (See Fig.4)
- Important, after cutting leave the Gauge in position and use a file to ensure the Spindle end is flat and square, (See Fig.4)
- Remove the "Cut-off" Gauge and de-burr any sharp edges from the inside of the locknut. (See Fig.5)
- Attach the Spindle Handle Adapter and ensure the Set screw engagement slot is positioned underside. (See Fig.5)
- Fit and tighten the Adapter Screw to secure the Spindle handle Adapter. (See Fig.6)
- Attach Handle to Spindle Handle Adapter. (See Fig.6)
- Align the Handle so that the Set screw locates into the engagement Slot. (See Fig.7)
- Fine tune the Handle position and then tighten the Set Screw using a 2.5mm Allen Key. (Tighten well)
- Note the Handle should have 2-3mm clearance from the Finished Wall Surface.
- After completing the installation, establish water supply, check function of Tapware and ensure no water leaks.

April 2016

Plumbers, please ensure a copy of the Installation Instructions are left with the end user for future reference



Milli Pure Wall Top Assemblies

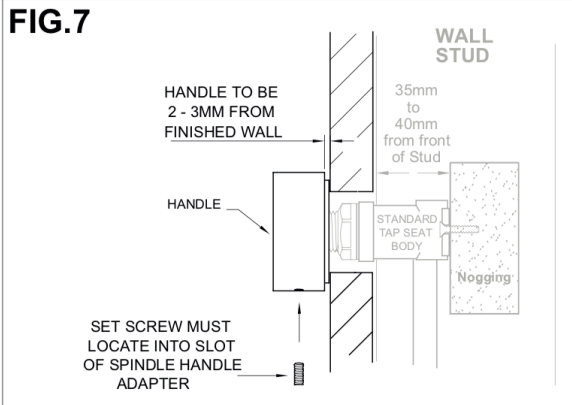
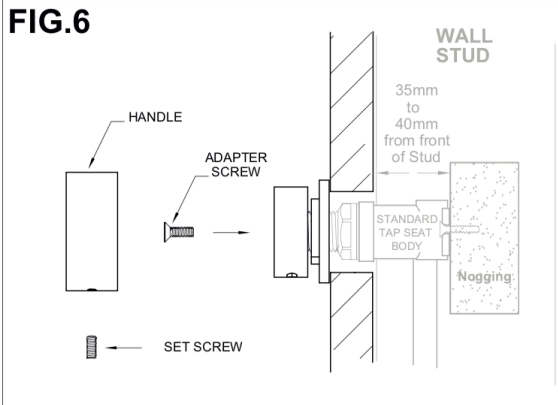
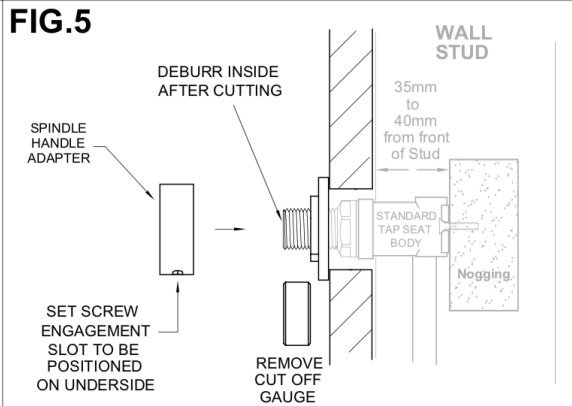
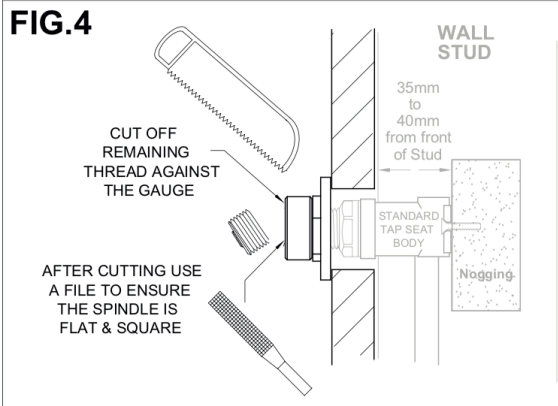
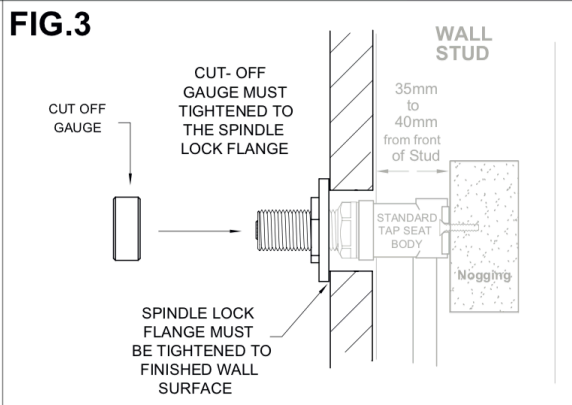
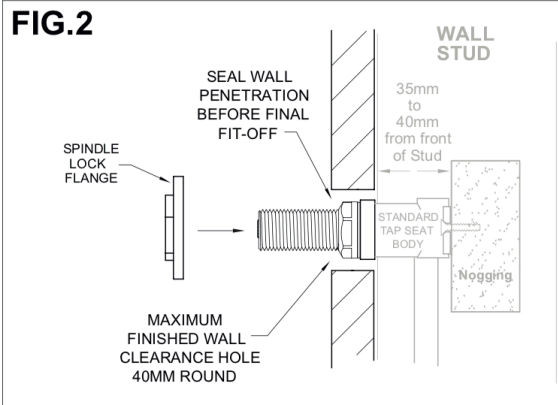
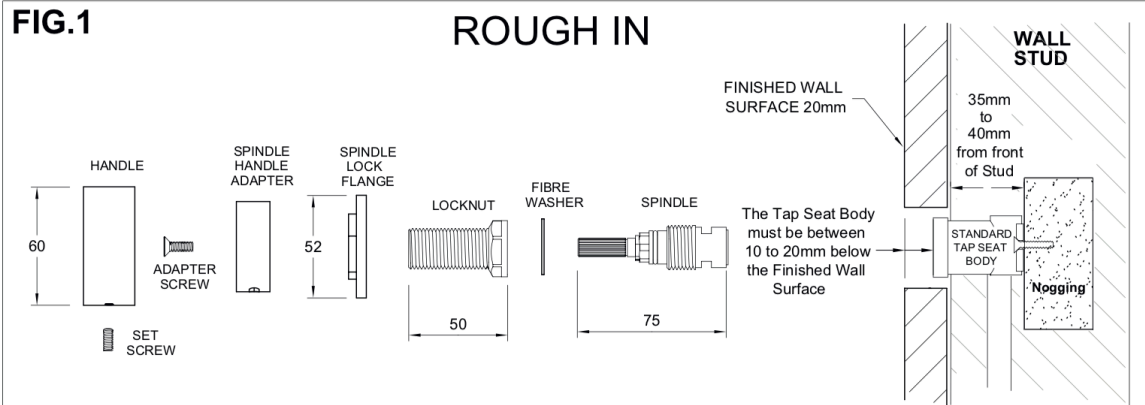

Plumbers, please ensure a copy of the Installation Instructions are left with the end user for future reference