

Technical Specifications

APPLICATION

- Used in hydrant systems to protect against fires in and around residential and commercial buildings
- Suitable for NSW and ACT

CERTIFICATION

- Standards Mark Certificate – SMK21674
- Manufactured, inspected, and checked in accordance with AS2419.2
- Storz fitting complies with NEN3374



PERFORMANCE

| | |
|---------------------|---------|
| Working Pressure | 1600kPa |
| Test Pressure | 2700kPa |
| Maximum Temperature | 60°C |

PRODUCT DATA

| | |
|--------------|---------------------------------------|
| Valve Inlet | 80mm Roll Groove with 65mm Female BSP |
| Valve Outlet | Loctite Storz |
| Weight | 4.3kg |





MATERIALS

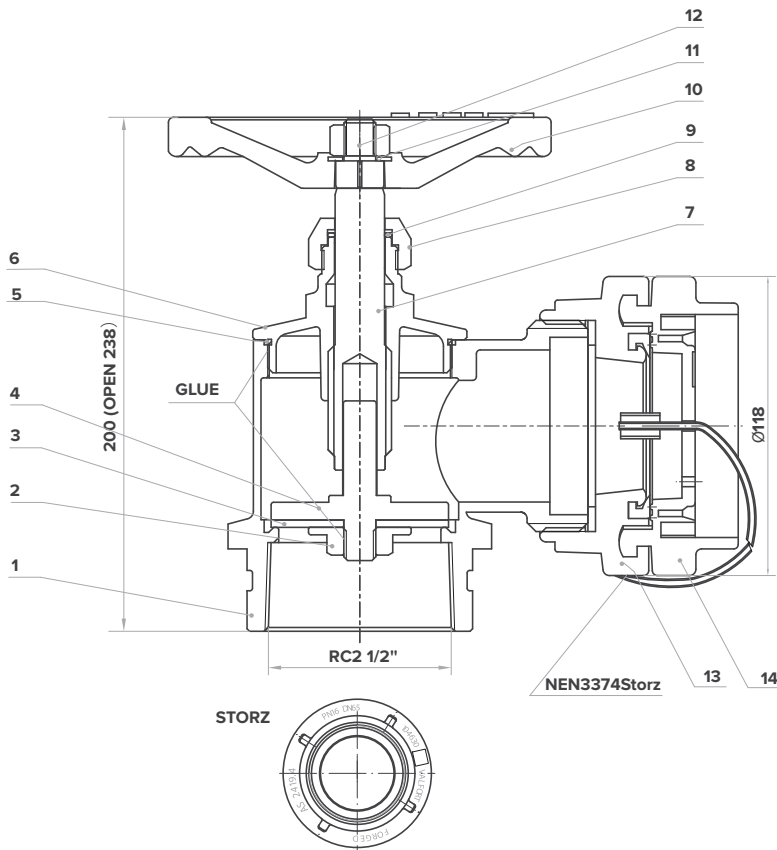

| # | PART NAME | QTY | MATERIAL |
|----|---------------------|-----|----------|
| 1 | Body | 1 | C83600 |
| 2 | Nut | 1 | C48600 |
| 3 | Disk Washer | 1 | NBR |
| 4 | Disk | 1 | C48600 |
| 5 | Body to Bonnet Seal | 1 | NBR |
| 6 | Bonnet | 1 | C83600 |
| 7 | Stem | 1 | C48600 |
| 8 | Stem Seal | 1 | C48600 |
| 9 | O-Ring | 1 | NBR |
| 10 | Handwheel | 1 | T200 |
| 11 | Washer | 1 | STS316 |
| 12 | Nut | 1 | STS316 |
| 13 | 2 1/2" Storz | 1 | |
| 14 | Cap & Chain | 1 | |

NOTE

- Body thickness is equal to or greater than 3mm.
- The number of complete turns of the handwheel to fully open or fully close shall not exceed 10.

SPARE PARTS

The following kits are available at Reece. Individual spare parts may be ordered on request.

| DESCRIPTION | PRODUCT CODE |
|---|--------------|
| Valfort Landing Valve Handle Spares Kit | 1539764 |
| Valfort Landing Valve Stem Spares Kit | 1539768 |
| Valfort Landing Valve Jumper Valve Kit | 1539773 |

MAINTENANCE INSTRUCTIONS

This hydrant landing valve requires routine servicing and maintenance in accordance with AS1851.