

SOLOLIFT2 C-3 & D-2

COMPACT GREY WATER HANDLING STATIONS



WATER SOURCE



Grey Water

APPLICATION



Grey Water Handling

- Options to suit most domestic applications
- Space saving design allows these units to be installed in small spaces
- Highly flexible connections make for low cost installation
- Very easy to clean and maintain

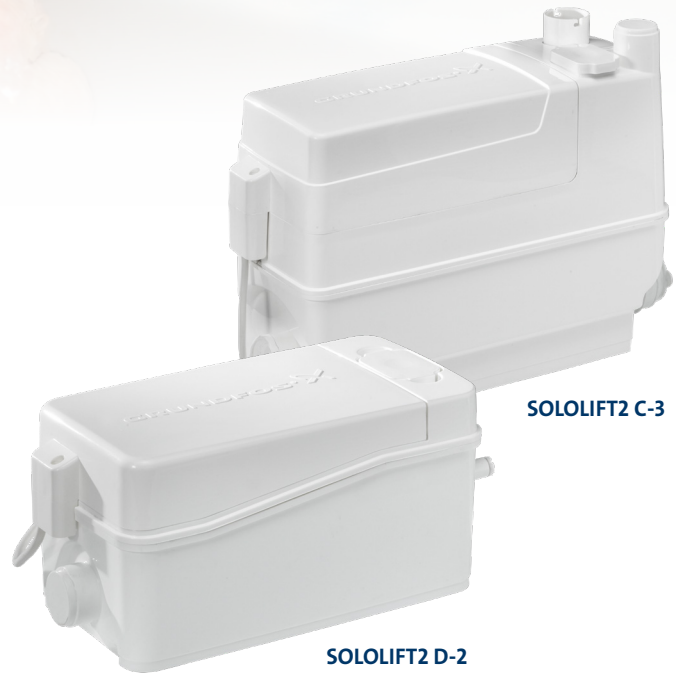

SOLOLIFT2 C-3

SOLOLIFT2 D-2

SOLOLIFT2 SELECTOR

C-3



Connect up to **THREE** grey water sources

D-2



Connect up to **TWO** grey water sources

Handbasin/Sink with cabinet



Shower



Bath



Extra Handbasin



Washing Machine



Dishwasher



- Ideal for installation in a bathroom or laundry with an under-sink
- Choose from any combination of these additional sources up to the maximum number of inlets available

be
think
innovate

GRUNDFOS

FIND SPACE FOR YOUR PUMP

The SOLOLIFT2 range has been designed to fit into confined spaces. See below the space required for the installation of each model in the C-3 & D-2 range.

C-3

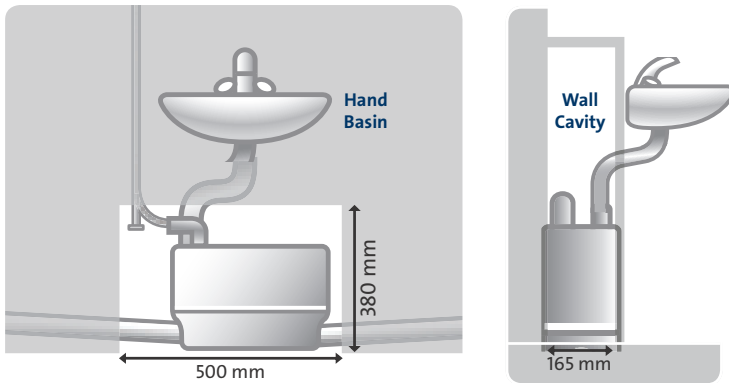

D-2

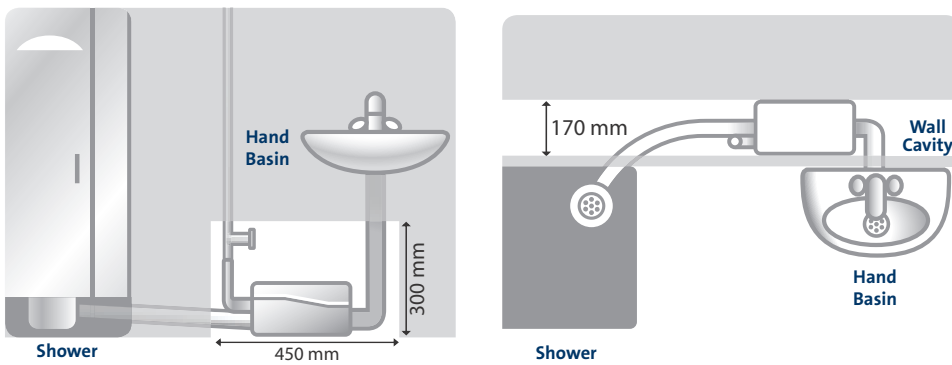

C-3

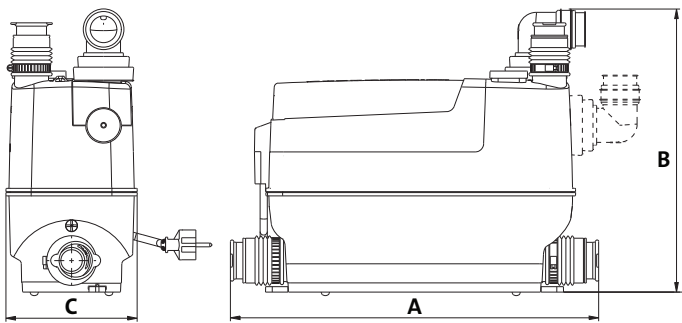

D-2

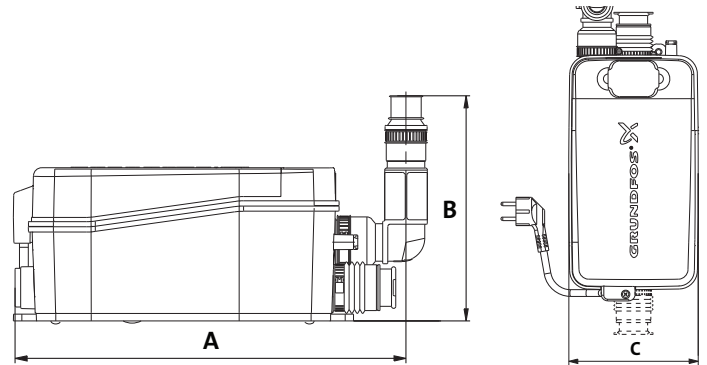

Model	Dimensions (mm)		
	A (l)	B (h)	C (w)
SOLOLIFT2 C-3	444	255	158
SOLOLIFT2 D-2	376	147	164