

SuperSTOPPER®

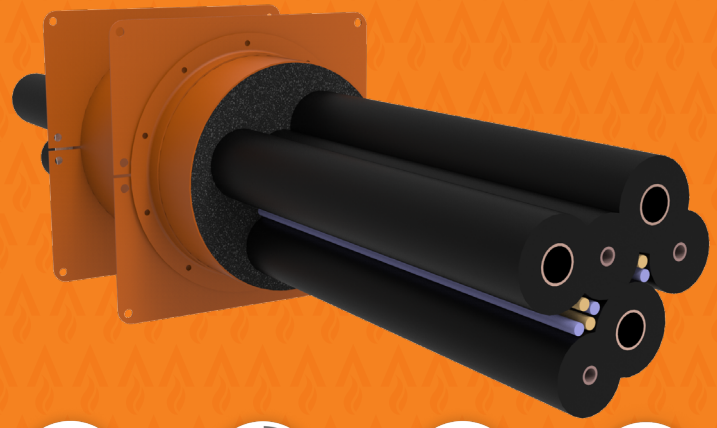

The SuperSTOPPER® is an advanced retrofit multi-service penetration system engineered to effectively contain and prevent the spread of fire through narrow service penetrations, all within a remarkably compact design. This innovative product, tested with the SuperSTOPPER® range, has undergone extensive rigorous testing with various combinations of service types and bundles within standard wall, ceiling and floor fire barriers. It proudly stands as one of the most extensively fire-tested solutions globally, boasting industry-leading Fire Resistance Levels (FRLs) of up to -/240/240

(system specific).



FIRE STOP



SMOKE STOP



SOUND STOP



AIR STOP



MOVEMENT STOP

YOU NO LONGER HAVE TO TRY AND FIT A SQUARE BOX IN A ROUND HOLE!

Click to Watch Installation Video



KEY FEATURES



- Allows multiple and mixed services to pass through one opening
- Circular shape for ease of making holes
- Mixed services approved in any quantity or configuration
- Retro-fit or new construction
- Space saving, eliminates the need for 200mm separation between adjacent services
- Tested in Hebel®, single/ double layer plasterboard, Speedpanel® and many other common wall/floor systems
- Friendly FyreFLANGE for mounting
- Fire tested in independent laboratories
- Fire tested on ceilings
- Thoroughly tested to AS1530.4-2014
- No need to frame/line plasterboard wall penetrations

APPLICATIONS



Electricians	Power(AL and Cu core) Data cables Conduits Fibre Cables
Plumbers	Steel and Copper pipes PVC pipes PEX pipes PEX-AL-PEX pipes
HVAC&R	Insulated pipes
Active Fire	Sprinkler pipes Fire cables

TRADES



Diagram showing trade icons in circular frames:

- BUILDERS (Hammer icon)
- ELECTRICIANS (Plug icon)
- ARCHITECT (Compass icon)
- PLASTERERS (Trowel icon)
- FIRE MAINTENANCE (Building with gear icon)
- PLUMBERS (Wrench icon)
- DATA AND COMMUNICATIONS (Server rack icon)
- PASSIVE FIRE PROFESSIONALS (Flame icon)
- HVAC&R (Snowflake icon)

TABLE OF CONTENTS



Section		Page
System Range		3
Benefits		4
FyreFLANGE		5
System Selector		6
Fire Resistance Level		7
FRL Tables	Plasterboard 60min	8
	Plasterboard 90min	9
	Plasterboard 120min	10
	XCEM Alpha Panel Wall 60min	11
	XCEM Alpha Panel Wall 90min	12
	AAC Panel Wall 90min	13
	AAC Panel Wall 120min	14
	Concrete/Masonry 120min	15
	Concrete/Masonry 240min	16
	Speedpanel® 120min	17
	Laminated Shaftwall	18
	Trafalgar COREX Shaftwall	19
	Concrete Floor Slabs 120min	20
	Concrete Floor Slabs 240min	21
	Fire Rated Ceilings	22
Installation	Stage 1: All Walls	23
	SuperSTOPPER® Stage 2: Wall Types	25
	Installation Alternatives: FyreBOARD Maxilite®	26
Compliance		27
FAQ		28
Technical Drawings		29

SuperSTOPPER - CIRCULAR

Ideal for fire sealing of circular holes that are cut in Fire Barriers

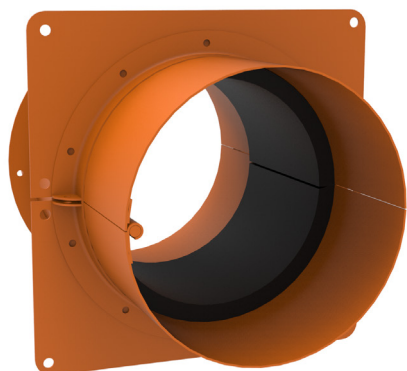

SuperSTOPPER & FyreFLANGE



Type	Item Number	Dimensions W x H x D or Diam	Dimensions
SuperSTOPPER®	SUPERSTOPPER-C-50	50 x 250mm	
	SUPERSTOPPER-C-100	100 x 250mm	
	SUPERSTOPPER-C-150	150 x 250mm	

SuperSTOPPER® SYSTEMS COMPONENTS

Item Number	Description	Min Order Qty	Pallet Qty
FLANGE-R-50mm	to suit SUPERSTOPPER-C-50	part of assembly	Learn More
FLANGE-R-100mm	to suit SUPERSTOPPER-C-100	part of assembly	Learn More
FLANGE-R-150mm	to suit SUPERSTOPPER-C-150	part of assembly	Learn More
FYREFLEX 300W/G	300ml White/Grey Cartridge	1	1920
FYREFLEX 600W/G	600ml White/Grey Sausage	20	1040
TWRAP 300	300mm wide, 25mm thick blanket	7620mm long roll	24
TWRAP 450	450mm wide, 25mm thick blanket	7620mm long roll	12
TWRAP 600	600mm wide, 25mm thick blanket	7620mm long roll	12

BENEFITS

WHY SuperSTOPPER®?

Trafalgar's SuperSTOPPER® Circular stands as a cutting-edge solution for containing not just fire but also a range of other crucial elements within service penetrations in modern-day buildings. It was meticulously developed to provide the **ultimate in containment or SUPER containment properties, addressing various needs, including fire, smoke, sound, energy, air leakage, and even the challenges of stringent seismic movements. The SuperSTOPPER is the answer to today's multifaceted containment requirements.**

Innovatively engineered with an intumescent lining, the SuperSTOPPER® effectively halts the spread of fire through openings. The SuperSTOPPER® Range, akin to versatile fire-rated holes, is designed to adapt seamlessly to diverse scenarios. The circular shape of the SuperSTOPPER® is not only functional but also practical, allowing for quick, neat, and cost-effective hole preparations in fire barriers. Whether it's a core hole in a concrete floor slab or a hole saw in a plasterboard wall, openings can be conveniently sized to accommodate a SuperSTOPPER.

The standout feature of the SuperSTOPPER® is its fast response to fire exposure. As a fire takes hold, the intumescent material inside the SuperSTOPPER® expands swiftly, forming a robust and tight seal around the services, and it's even capable of crushing plastic pipes if necessary. Each SuperSTOPPER® is equipped with intumescent foam plugs, further enhancing its reliability, minimizing smoke leakage, and improving acoustic properties. Additionally, this design takes into account future modifications, making it adaptable to changes, additions, and moves in services.

One of the key advantages of the SuperSTOPPER® is its extensive fire testing, which covers both empty and full states. Rigorous testing has been undertaken to account for a wide spectrum of service types, including multiple and mixed services. This eliminates the need to separate service penetrations, offering contractors the convenience of running various services through a single penetration.



FyreFLANGE FOR SuperSTOPPER®

SYSTEM APPLICATIONS

SuperSTOPPER® Circular systems are suitable for use in any building where penetrations are made through fire rated plasterboard, Speedpanel®, Hebel®, Walsc®, Pronto Panel, FyreBOARD Maxilite®, masonry/concrete walls and concrete floors. They have been tested and approved for the following services:

- Electrical (copper and aluminium) cables
- Data, communication cables and NBN and other fibre cables
- Steel and copper pipes
- Pair coil and CHW pipes (copper and PEX)
- Heat trace cables
- CPVC sprinkler pipes
- Small conduits
- PVC pipes (floors only)
- PEX and Gas PEX-AL-PEX
- NBN and other fibre cables

WHAT IS FYREFLANGE?

Every SuperSTOPPER® system now includes the Trafalgar FyreFLANGE for seamless integration with the Superstopper. This square and innovative component is designed to accommodate real-world annular gaps in fire barriers. The Trafalgar FyreFLANGE provides a friction-fit solution for securely positioning the SuperSTOPPER® without requiring any drilling into the fire barrier. The latest testing has demonstrated that with the FyreFLANGE mounting brackets, the SuperSTOPPER® or Maxi can effectively cover annular gaps of up to 20mm, expanding its suitability for a broader range of penetrations. In situations where even larger annular gaps are encountered on-site, you can contact Trafalgar Fire for custom mounting flange systems, or opt for the use of FyreBOARD Maxilite®. This enhanced flexibility makes the SuperSTOPPER® system a versatile choice for fire protection needs.



Product	Depth mm	Height mm	Width mm	FyreFLANGE Dimensions
FyreFLANGE Mini Round 50	16	110	110	
FyreFLANGE Mini Round 100	16	160	160	
FyreFLANGE Mini Round 150	16	210	210	

SYSTEM SELECTOR

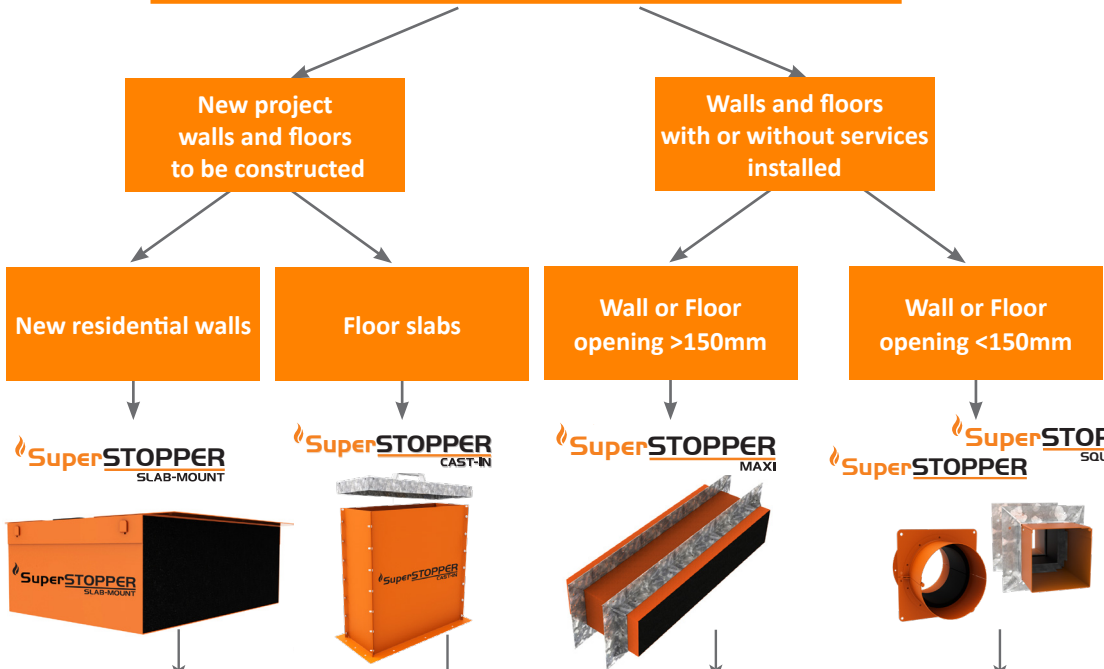

Installation Prior to Fire Barrier Construction		✓	✓	✗	✗	
Hole Cutting Required		✗	✗	✓	✓	
Fire Barrier	Floors	Concrete Slab	✗	✓	✓	
		FyreSET® Mortar	✗	✓	✗	
	Walls	Masonry Walls	✓	✗	✓	✓
		Concrete Walls	✓	✗	✓	✓
		Plasterboard	✓	✗	✓	✓
		Hebel® / Wasc®	✓	✗	✓	✓
		SpeedPanel®	✓	✗	✓	✓
		Alpha Panel®	✓	✗	✓	✓
		COREX walls	✓	✗	✓	✓
		FyreBOARD Maxilite™	✓	✗	✓	✓
	FyreBATT	✗	✗	✗	✓	
	Ceilings	Plasterboard Ceiling	✗	✗	✓	✓
COREX ceilings		✗	✗	✓	✓	
Services	Power Cables	✓	✓	✓	✓	
	Data Cables	✓	✓	✓	✓	
	Cable Trays	✓	✓	✓	✗	
	Steel and Copper Pipes	✓	✓	✓	✓	
	Aluminium Cables	✓	✓	✓	✓	
	CPVC Pipes	✓	✓	✓	✓	
	PVC Pipes	✗	✓	Floors Only	Floors Only	
	PEX	✓	✓	✓	✓	
	PEX-AL-PEX	✓	✓	✓	✓	
	Insulated Copper/PEX	✓	✓	✓	✓	
	Pair Coils	✓	✓	✓	✓	

For full FRL details please consult the relevant technical guide or contact Trafalgar Fire. Fire testing of Trafalgar Fire products is always ongoing.

FIRE RESISTANCE LEVEL

FIRE RATING – HOW IS FIRE PERFORMANCE MEASURED?

An FRL (fire resistance level) is a handy way of summarising the performance of a building element. It consists of 3 numbers, all given in minutes:

FRL 120/120/120

(example)



Structural Adequacy

The ability of the building element to support the weight of adjacent building elements.

ie: a brick wall supporting a concrete floor slab above.



Integrity

The ability of an element to prevent the passage of flames and hot gasses.

ie: a plasterboard wall remaining intact and not allowing holes to form.

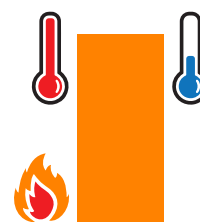

Insulation

The ability of an element to resist heat transfer from the exposed face to the unexposed face.

ie: a bundle of cables remaining below a set temperature limit on the unexposed side of the wall penetration system.

Penetrations are not required to have a Structural Adequacy rating and is usually expressed as a dash. For example, a penetration through a 2-hour load bearing wall would be written as -/120/120.

INTEGRITY

The SuperSTOPPER® system will achieve the integrity performance for up to 2 hours physically stopping the direct spread of fire, however the insulation performance of the penetration will be limited to the type of wall being used and conductivity of the services in the penetration.

INSULATION (TEMPERATURE RISE)

Heat transfer via conduction (or heat rise) will occur through the conductive parts of any penetration system. To limit the heat rise through the SuperSTOPPER® penetration systems, our 25mm thick TWRAP foil encased blanket can be wrapped around the services and metal casing of the SuperSTOPPER® to achieve up to 2 hours of insulation performance. There are some applications that won't require any TWRAP to achieve the full FRL, please refer to the tables below for specific details.

60 MINUTE PLASTERBOARD STUD WALLS -WRAP FREE!

**PATCH FREE!
WRAP FREE!**



Minimum of 13mm fire grade plasterboard on each face of steel or timber stud, of minimum 64mm thickness with a stated FRL of -/60/60

Service Type	Service Specification		FRL - WRAP FREE	
			64mm stud*	92mm studs
Plastic Pipes	PVC Pipes	Up to 32mm OD	-/60/30	-/60/60
	PEX Pipes	Up to 20mm	-/60/30	-/60/60
		Up to 32mm	-/60/30	-/60/60
		Up to 32mm with 19mm E-Flex insulation	-/60/30	-/60/60
	PEX-Al-PEX pipes	Up to 25mm	-/60/30	-/60/60
		Up to 32mm	-/60/-	-/60/-*
		Up to 32mm with 19mm E-Flex insulation	-/60/30	-/60/60
cPVC Pipes	Up to 40mm	-/60/-	-/60/-*	
	40mm to 60mm	-/60/30	-/60/60	
Bare Metal Pipes	Copper	Up to 50mm	-/60/-	-/60/-*
	Steel	up to 60mm	-/60/30	-/60/60
Metal Pipes Insulated**	Copper	Up to 50mm OD with PE insulation up to 20mm thick	-/60/30	-/60/30*
		Up to 50mm OD with FR insulation	-/60/30	-/60/60
		Up to 20mm OD with 38mm rockwool-type insulation	-/60/30	-/60/60
	Pair coil	Up to 9.5 & 19mm with 20mm FR insulation (or 13mm PE)	-/60/30	-/60/60
Power Cables - Copper Core	TPS	Up to 12x 2.5mm ² per bundle	-/60/30	-/60/60
	Rigid or Flexible PVC Conduits	Up to 32mm OD (with any size power or comms cables up to 32mm diameter)	-/60/30	-/60/60
	AS1530.4 Appendix D1 cable set	Applies to copper core power cables	-/60/30	-/60/30*
Power Cables - Aluminium Core	Single Core cables	Bundles of up to 3 x 240mm ² , 4 x 120mm ² and 9 x 70mm ² per bundle (16x cables total)	-/60/30	-/60/30*
Communications Cables	Fibre Optic Cable	NBN grade cable	-/60/30	-/60/60
	RG6 coax	Up to 3x per bundle	-/60/30	-/60/60
	AS1530.4 Appendix D2 cable set	Applies to copper core comms cables	-/60/30	-/60/60
Conduits	Rigid or Flexible PVC Conduits	Up to 32mm OD (with any size power or comms cables up to 32mm diameter)	-/60/30	-/60/60

*TWrap required on these specific services to achieve -/60/60 FRL. Refer to FC10266 for details in specific wall types.

**With or without heat trace cable.

90 MINUTE PLASTERBOARD STUD WALLS

Minimum of 16mm fire grade plasterboard on each face of a steel or timber stud of minimum 64mm thickness, with a stated FRL of -/90/90.

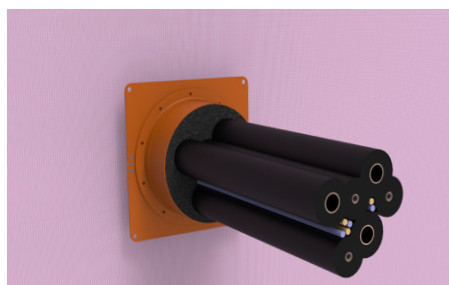

Service Type	Service Specification		FRL (Wrap Free)	FRL with TWRAP™	TWRAP™ Length required (mm)
Plastic Pipes	PVC Pipes	Up to 32mm OD	-/90/60	-/90/90	300
	PEX Pipes	Up to 20mm	-/90/60		300
		Up to 32mm	-/90/60		450
		Up to 32mm with 19mm E-Flex insulation	-/90/60		300
	PEX-Al-PEX pipes	Up to 25mm	-/90/60		300
		Up to 32mm	-/90/-		450
		Up to 32mm with 19mm E-Flex insulation	-/90/30		300
	cPVC Pipes	Up to 40mm	-/90/-		300
40mm to 60mm		-/90/60	300		
Bare Metal Pipes	Copper	Up to 50mm	-/90/-	300	
	Steel	up to 60mm	-/90/30	300	
Metal Pipes Insulated*	Copper	Up to 50mm OD with PE insulation up to 20mm thick	-/90/30	300	
		Up to 50mm OD with FR insulation	-/90/30	300	
		Up to 20mm OD with 38mm rockwool-type insulation	-/90/30	300	
	Pair coil	Up to 9.5 & 19mm with 20mm FR insulation (or 13mm PE)	-/90/30	300	
Power Cables - Copper Core	TPS	Up to 12x 2.5mm ² per bundle	-/90/30	300	
	AS1530.4 Appendix D1 cable set	Applies to copper core power cables	-/90/30	300	
Power Cables Aluminium Core	Single Core cables	Bundles of up to 3 x 240mm ² , 4 x 120mm ² and 9 x 70mm ² per bundle (16x cables total)	-/90/30	300	
Communications Cables	Fibre Optic Cable	NBN grade cable	-/90/30	300	
	RG6 coax	Up to 3x per bundle	-/90/30	300	
	AS1530.4 Appendix D2 cable set	Applies to copper core comms cables	-/90/30	300	
Conduits	Rigid or Flexible PVC Conduits	Up to 32mm OD (with or without cables)	-/90/60	300	

*Heat trace cables may be installed underneath thermal lagging through a SuperSTOPPER® penetration

120 MINUTE PLASTERBOARD STUD WALLS

Minimum of 2x13mm fire grade plasterboard on each face of steel or timber stud, of minimum 64mm thickness with a stated FRL of -/120/120. Please note SuperSTOPPER® does not require the penetration to be lined and framed.



Service Type	Service Specification		FRL (Wrap Free)	FRL with TWRAP™ (all studs)	TWRAP™ Length required (mm)
Plastic Pipes	PVC Pipes	Up to 32mm OD	-/120/60	-/120/120	300
	PEX Pipes	Up to 20mm	-/120/60		300
		Up to 32mm	-/120/60		450
	PEX-Al-PEX pipes	Up to 20mm	-/120/60		300
		Up to 32mm	-/120/-		450
	cPVC Pipes	Up to 40mm	-/120/-		300
40mm to 60mm		-/120/60	300		
Bare Metal Pipes	Copper	Up to 50mm	-/120/-		300
	Steel	up to 60mm	-/120/60		300
Metal Pipes Insulated*	Copper	Up to 50mm OD with PE insulation up to 20mm thick	-/120/60		300
		Up to 50mm OD with FR insulation	-/120/60		300
		Up to 20mm OD with 38mm rockwool-type insulation	-/120/60		300
	Pair coil	Up to 9.5 & 19mm with 20mm FR insulation (or 13mm PE)	-/120/60	300	
Power Cables - Copper Core	TPS	Up to 12x 2.5mm ² per bundle	-/120/60	300	
	AS1530.4 Appendix D1 cable set	Applies to copper core power cables	-/120/60	600	
Power Cables Aluminium Core	Single Core cables	Bundles of up to 3 x 240mm ² , 4 x 120mm ² and 9 x 70mm ² per bundle (16x cables total)	-/120/30	300	
Communications Cables	Fibre Optic Cable	NBN grade cable	-/120/60	300	
	RG6 coax	Up to 3x per bundle	-/120/60	300	
	AS1530.4 Appendix D2 cable set	Applies to copper core comms cables	-/120/60	450	
Conduits	Rigid or Flexible PVC Conduits	Up to 32mm OD (with or without cables)	-/120/60	300	
Drinks python***	Lagged post mix lines	90mm OD 10x post mix lines with 19mm FR thermal lagging	NA	300	

*Heat trace cables may be installed underneath thermal lagging through a SuperSTOPPER® penetration

***Applies to the SuperSTOPPER®-R-150 only

60 MINUTE XCEM ALPHA PANEL WALLS

Type 1 - 35mm Alpha Panel, framed with stud and lined on the other face with 13mm plasterboard (88mm minimum thickness) shown on the right.

Type 2 - 35mm Alpha Panel, framed with stud on both sides, lined on both faces with 13mm plasterboard (200mm minimum thickness) not shown.



Service Type	Service Specification		FRL - WRAP FREE		FRL with TWRAP™	
			Type 1	Type 2	Both walls	Length required (mm)
Plastic Pipes	PVC Pipes	Up to 32mm OD	-/60/30	-/60/60	-/60/60	300
	PEX Pipes	Up to 20mm	-/60/30	-/60/60		300
		Up to 32mm	-/60/30	-/60/60		450
		Up to 32mm with 19mm E-Flex	-/60/30	-/60/60		300
		Up to 25mm	-/60/30	-/60/60		300
	PEX-Al-PEX pipes	Up to 32mm	-/60/-	-/60/-		450
		Up to 32mm with 19mm E-Flex	-/60/30	-/60/60		300
		cPVC Pipes	Up to 40mm	-/60/-		-/60/-
Bare Metal Pipes	Copper	Up to 50mm	-/60/-	-/60/-		300
	Steel	up to 60mm	-/60/30	-/60/60		300
Metal Pipes Insulated*	Copper	Up to 50mm OD with PE insulation up to 20mm thick	-/60/30	-/60/30		300
		Up to 50mm OD with FR insulation	-/60/30	-/60/60		300
		Up to 20mm OD with 38mm rockwool-type insulation	-/60/30	-/60/60		300
	Pair coil	Up to 9.5 & 19mm with 20mm FR insulation (or 13mm PE)	-/60/30	-/60/60		300
Power Cables - Copper Core	TPS	Up to 12x 2.5mm ² per bundle	-/60/30	-/60/60	300	
	AS1530.4 Appendix D1 cable set	Applies to copper core power cables and cable trays up to 1000mm wide	-/60/30	-/60/30	300	
Power Cables Aluminium Core	Single Core cables	Bundles of up to 3 x 240mm ² , 4 x 120mm ² and 9 x 70mm ² per bundle (16x cables total)	-/60/30	-/60/30	300	
Communications Cables	Fibre Optic Cable	NBN grade cable	-/60/30	-/60/60	300	
	RG6 coax	Up to 3x per bundle	-/60/30	-/60/60	300	
	AS1530.4 Appendix D2 cable set	Applies to copper core comms cables, including cable trays up to 1000mm wide	-/60/30	-/60/60	300	
Conduits	Rigid or Flexible PVC Conduits	Up to 32mm OD (with or without cables)	-/60/30	-/60/60	300	

*Heat trace cables may be installed underneath thermal lagging through a SuperSTOPPER® penetration

90 MINUTE XCEM ALPHA PANEL WALLS

Type 3 - 35mm Alpha Panel, framed with stud and lined on the other face with 16mm fire grade plasterboard (91mm minimum thickness).

Type 4 - 35mm Alpha Panel laminated with 16mm fire grade plasterboard, shown on the right.



Service Type	Service Specification		FRL (Wrap Free)**		FRL with TWRAP™	
			Type 3	Type 4	Both walls	Length required (mm)
Plastic Pipes	PVC Conduits	Up to 32mm OD	-/90/60	-/90/30	-/90/90	450
	PEX Pipes	Up to 20mm	-/90/60	-/90/30		450
		Up to 32mm	-/90/60	-/90/30		450
		Up to 32mm with 19mm E-Flex	-/90/60	-/90/30		450
	PEX-Al-PEX pipes	Up to 25mm	-/90/60	-/90/30		450
		Up to 32mm	-/90/-	-/90/-		450
		Up to 32mm with 19mm E-Flex insulation	-/90/30	-/90/30		450
	cPVC Pipes	Up to 40mm	-/90/-	-/90/-		450
40mm to 60mm		-/90/60	-/90/30	450		
Bare Metal Pipes	Copper	Up to 50mm	-/90/-	-/90/30		450
	Steel	up to 60mm	-/90/30	-/90/30		450
Metal Pipes Insulated*	Copper	Up to 50mm OD with PE insulation up to 20mm thick	-/90/30	-/90/30		450
		Up to 50mm OD with FR insulation	-/90/30	-/90/30		450
		Up to 20mm OD with 38mm rockwool-type insulation	-/90/30	-/90/30		450
	Pair coil	Up to 9.5 & 19mm with 20mm FR insulation (or 13mm PE)	-/90/30	-/90/30		450
Power Cables - Copper Core	TPS	Up to 12x 2.5mm ² per bundle	-/90/30	-/90/30		450
	AS1530.4 Appendix D1 cable set	Applies to copper core power cables and cable trays up to 1000mm wide	-/90/30	-/90/30	450	
Power Cables Aluminium Core	Single Core cables	Bundles of up to 3 x 240mm ² , 4 x 120mm ² and 9 x 70mm ² per bundle (16x cables total)	-/90/30	-/90/30	450	
Communications Cables	Fibre Optic Cable	NBN grade cable	-/90/30	-/90/30	450	
	RG6 coax	Up to 3x per bundle	-/90/30	-/90/30	450	
	AS1530.4 Appendix D2 cable set	Applies to copper core comms cables, including cable trays up to 1000mm wide	-/90/30	-/90/30	450	
Conduits	Rigid or Flexible PVC Conduits	Up to 32mm OD (with or without cables)	-/90/60	-/90/30	450	

*Heat trace cables may be installed underneath thermal lagging through a SuperSTOPPER® penetration

**Wrap free FRL's require a patch of 60mm Maxilite board 100mm strips on one side of the wall.

90 MINUTE AAC PANELS

Hebel, Waslc or other AAC panels 75mm thick with a stated FRL up to -/90/90. Note if this wall is used for a-/60/60 apartment entry, please refer to page 9.



Service Type	Service Specification		FRL - WRAP FREE	FRL-With 300mm TWRAP
Plastic Pipes	PVC Pipes	Up to 32mm OD	-/90/30	-/90/90
	PEX Pipes	Up to 20mm	-/90/30	-/90/90
		Up to 32mm	-/90/30	-/90/90 (450mm TWrap)
		Up to 32mm with 19mm E-Flex insulation	-/90/30	-/90/90
	PEX-Al-PEX pipes	Up to 20mm	-/90/30	-/90/90
		Up to 25mm	-/90/30	-/90/90
		Up to 32mm	-/90/0	-/90/90 (450mm TWrap)
		Up to 32mm with 19mm E-Flex insulation	-/90/30	-/90/90
	cPVC Pipes	Up to 40mm	-/90/0	-/90/90
		40mm to 60mm	-/90/30	-/90/90
Bare Metal Pipes	Copper	Up to 50mm	-/90/0	-/90/90
	Steel	up to 60mm	-/90/30	-/90/90
Metal Pipes Insulated*	Copper	Up to 50mm OD with PE insulation up to 20mm thick	-/90/30	-/90/90
		Up to 50mm OD with FR insulation	-/90/30	-/90/90
		Up to 20mm OD with 38mm rockwool-type insulation	-/90/30	-/90/90
	Pair coil	Up to 9.5 & 19mm with 13mm PE insulation	-/90/30	-/90/90
		Up to 9.5 & 19mm with 20mm FR insulation	-/90/30	-/90/90
Power Cables - Copper Core	TPS	Up to 12x 2.5mm ² per bundle	-/90/30	-/90/90
	AS1530.4 Appendix D1 cable set	Applies to copper core power cables	-/90/30	-/90/90
	Rigid or Flexible PVC Conduits	Up to 32mm OD (with any size power or comms cables up to 32mm diameter)	-/90/30	-/90/90
Power Cables Aluminium Core	Single Core cables	Bundles of up to 3 x 240mm ² , 4 x 120mm ² and 9 x 70mm ² per bundle (16x cables total)	-/90/30	-/90/90
Communications Cables	Fibre Optic Cable	NBN grade cable	-/90/30	-/90/90
	RG6 coax	Up to 3x per bundle	-/90/30	-/90/90
	AS1530.4 Appendix D2 cable set	Applies to copper core comms cables	-/90/30	-/90/90
Conduits	Rigid or Flexible PVC Conduits	Up to 32mm OD (with any size power or comms cables up to 32mm diameter)	-/90/30	-/90/90

*With or without heat trace cable

120 MINUTE AAC PANELS

Hebel, Wasc or other AAC panels 75mm thick with a stated FRL up to -/120/120.



Service Type	Service Specification		FRL (Wrap Free)	FRL with TWRAP™	TWRAP™ Length required (mm)
Plastic Pipes	PVC pipes	Up to 32mm OD	-/120/30	-/120/120	300
	PEX Pipes	Up to 20mm	-/120/30		300
		Up to 32mm	-/120/30		450
	PEX-Al-PEX pipes	Up to 20mm	-/120/30		300
		Up to 25mm	-/120/30		450
		Up to 32mm	-/120/0		450
	cPVC Pipes	Up to 40mm	-/120/0		300
Up to 60mm		-/120/30	300		
Bare Metal Pipes	Copper	Up to 50mm	-/120/0	300	
	Steel	up to 60mm	-/120/30	300	
Metal Pipes Insulated*	Copper	Up to 50mm OD with PE insulation up to 20mm thick	-/120/30	300	
		Up to 50mm OD with FR insulation	-/120/30	300	
		Up to 20mm OD with 38mm rockwool-type insulation	-/120/30	300	
	Pair coil	Up to 9.5 & 19mm with 13mm FR insulation	-/120/30	300	
		Up to 9.5 & 19mm with 20mm FR insulation	-/120/30	300	
Power Cables - Copper Core	TPS	Up to 12x 2.5mm ² per bundle	-/120/30	300	
	AS1530.4 Appendix D1 cable set	Applies to copper core power cables	-/120/30	600#	
Power Cables Aluminium Core	Single Core cables	Bundles of up to 3 x 240mm ² , 4 x 120mm ² and 9 x 70mm ² per bundle (16x cables total)	-/120/30	300	
Communications Cables	Fibre Optic Cable	NBN grade cable	-/120/30	300	
	RG6 coax	Up to 3x per bundle	-/120/30	300	
	AS1530.4 Appendix D2 cable set	Applies to copper core comms cables	-/120/30	450#	
Conduits	Rigid or Flexible PVC Conduits	Up to 32mm OD (with or without cables)	-/120/60	300	

*With or without heat trace cable

#With 300mm of loose TWRap infill packed around the services within the wrap.

120 MINUTE CONCRETE, MASONRY AND PERMANANT FORMWORK WALLS

Walls designed as per AS3600 or AS3700 (or otherwise fire tested to achieved the required FRL with a minimum thickness as per the 90mm) including Dincel, AFS, Logically etc.



Service Type	Service Specification		FRL (Wrap Free)	FRL with TWRAP™ (all studs)	TWRAP™ Length required (mm)
Plastic Pipes	PVC Pipes	Up to 32mm OD	-/120/60	-/120/120	300
	PEX Pipes	Up to 20mm	-/120/60		300
		Up to 32mm	-/120/60		450
	PEX-Al-PEX pipes	Up to 20mm	-/120/60		300
		Up to 25mm	-/120/60		450
		Up to 32mm	-/120/0		450
	cPVC Pipes	Up to 40mm	-/120/0		300
40mm to 60mm		-/120/60	300		
Bare Metal Pipes	Copper	Up to 50mm	-/120/0		300
	Steel	up to 60mm	-/120/60		300
Metal Pipes Insulated*	Copper	Up to 50mm OD with PE insulation up to 20mm thick	-/120/60		300
		Up to 50mm OD with FR insulation	-/120/60		300
		Up to 20mm OD with 38mm rockwool-type insulation	-/120/60		300
	Pair coil	Up to 9.5 & 19mm with 13mm FR insulation	-/120/60		300
		Up to 9.5 & 19mm with 20mm FR insulation	-/120/60	300	
Power Cables - Copper Core	TPS	Up to 12x 2.5mm ² per bundle	-/120/60	300	
	AS1530.4 Appendix D1 cable set	Applies to copper core power cables	-/120/60	600	
Power Cables Aluminium Core	Single Core cables	Bundles of up to 3 x 240mm ² , 4 x 120mm ² and 9 x 70mm ² per bundle (16x cables total)	-/120/30	300	
Communications Cables	Fibre Optic Cable	NBN grade cable	-/120/0	300	
	RG6 coax	Up to 3x per bundle	-/120/60	300	
	AS1530.4 Appendix D2 cable set	Applies to copper core comms cables,	-/120/60	450	
Conduits	Rigid or Flexible PVC Conduits	Up to 32mm OD (with or without cables)	-/120/60	300	
Drinks python***	Lagged post mix lines	90mm OD 10x post mix lines with 19mm FR thermal lagging	NA	300	

*With or without heat trace cable.

***Applies to SuperSTOPPER®-R-150 only.

240 MINUTE CONCRETE, MASONRY AND PERMANANT FORMWORK WALLS

Walls designed as per AS3600 or AS3700 or otherwise fire tested to achieve an FRL of at least -/240/240, including Dintel, AFS, Logcall etc.

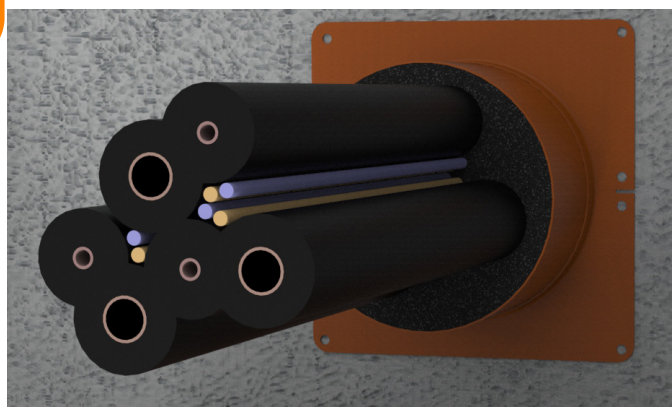

Service Type	Service Specification		FRL no wrap required	FRL with TWRAP	TWRAP Length required
Plastic Pipes	uPVC conduits Rigid or flexible (with or without cables)	up to 25mm OD	-/240/120	Wrap Free	-
Bare Metal Pipes	Copper pipes	up to 50mm OD	-/240/-	-/240/120	300mm
	Steel pipes	up to 50mm OD	-/240/60	-/240/120	300mm
Insulated Metal pipes	Copper pipes	up to 50mm OD with PE insulation up to 20mm thick	-/120/60	-/120/120	300mm
		up to 50mm OD with FR insulation	-/120/60	-/120/120	300mm
		up to 20mm OD with rockwool-type insulation	-/120/60	-/120/120	300mm
	2x Pair Coil	Up to 9.5 and 19mm OD with FR insulation up to 20mm thick	-/240/180	Wrap Free	-
	Pair coil pipes	up to 9.5 and 19mm OD with PE insulation up to 13mm thick	-/240/120	-/120/120	300mm
up to 9.5 and 19mm OD with FR insulation up to 20mm thick		-/240/120	-/120/120	300mm	
Power Cables	5 x 19mm OD 3C+E copper cables		-/240/180	Wrap Free	-
	Three core and Earth copper core cables up to 185mm ² (up to 54mm diameter)		-/240/60	-/120/120	600mm
	All other copper core power cables		-/240/60	-/120/120	600mm
Comms Cables	20 x CAT6 cable bundle		-/240/180	Wrap Free	-
	All other copper core power cables		-/120/60	-/120/120	450mm
PVC conduits	uPVC conduits Rigid or flexible (with or without cables)	Up to 25mm OD	-/240/180	Wrap Free	-

Where TWRAP is required for increased insulation performance, it is to be installed on both sides of the wall.

SPEEDPANEL® WALLS

Speedpanel walls of thickness ranging from 51mm (-/60/60), 64mm (-/90/90) and 78mm (-/120/120).

Note 51mm and 64mm Speedpanel walls required additional patch of 30mm Maxilite board on one side of the wall.



Service Type	Service Specification		51mm Speedpanel + 30mm Maxilite	64mm Speedpanel + 30mm Maxilite	78mm Speedpanel	TWrap Length required (mm)
Plastic Pipes	PVC pipes	Up to 32mm OD				300
	PEX Pipes	Up to 20mm				300
		Up to 32mm				450
		Up to 32mm with 19mm E-Flex**				450
		Up to 20mm				300
	PEX-AL-PEX pipes	Up to 32mm				450
		Up to 32mm with 19mm E-Flex**				450
		cPVC Pipes				Up to 40mm
Bare Metal Pipes	Copper	Up to 50mm				300
	Steel	up to 60mm				300
Metal Pipes Insulated#	Copper	Up to 50mm OD with PE insulation up to 20mm thick	-/60/60	-/90/90	-/120/120	300
		Up to 50mm OD with FR insulation				300
		Up to 20mm OD with 38mm rockwool-type insulation				300
	Pair coil	Up to 9.5 & 19mm with 13mm PE insulation				300
		Up to 9.5 & 19mm with 20mm FR insulation				300
Power Cables - Copper Core	TPS	Up to 12x 2.5mm ² per bundle				300
	AS1530.4 Appendix D1 cable set	Applies to copper core power cables				600*
Power Cables Aluminium Core	Single Core cables	Bundles of up to 3 x 240mm ² , 4 x 120mm ² and 9 x 70mm ² per bundle (16x cables total)				300
Communications Cables	Fibre Optic Cable	NBN grade cable				300
	RG6 coax	Up to 3x per bundle				300
	AS1530.4 Appendix D2 cable set	Applies to copper core comms cables				450*
Conduits	Rigid or Flexible PVC Conduits	Up to 32mm OD (with or without cables)				300

*300mm loose TWrap infill underneath Twrap

** Maximum FRL-/90/90

#With or without heat trace cable

For specific service based FRL's without using TWrap, refer to report FC10266

LAMINATED PLASTERBOARD SHAFT WALLS

Minimum of 3x fire grade plasterboard on one side of a steel stud with a stated FRL of 90 or 120 minutes. SuperSTOPPER® penetration thickened with 60mm Maxilite in 100mm strips on one side of the pene-



Service Type	Service Specification		Plasterboard outside minimum 64mm stud (FRL wrap Free)		FRL with TWRAP	TWrap Length required (mm)
			3x13mm plaster	3x16mm plaster		
Plastic Pipes	PVC Conduits	Up to 32mm OD	-/90/30	-/120/30	-/120/120 (Limited to the FRL of the wall)	300
	PEX Pipes	Up to 20mm	-/90/30	-/120/30		300
		Up to 32mm	-/90/30	-/120/30		450
		Up to 32mm with 19mm E-Flex insulation	-/90/30	Not approved		300 (-/90/90 only)
		Up to 25mm	-/90/30	-/120/30		450
	PEX-Al-PEX pipes	Up to 32mm	-/90/-	-/120/30		450
		Up to 32mm with 19mm E-Flex insulation	-/90/30	Not approved		300 (-/90/90 only)
		cPVC Pipes	Up to 40mm	-/90/-		-/120/-
40mm to 60mm	-/90/30		-/120/30	300		
Bare Metal Pipes	Copper	Up to 50mm	-/90/-	-/120/-		300
	Steel	up to 60mm	-/90/30	-/120/30	300	
Metal Pipes Insulated**	Copper	Up to 50mm OD with PE insulation up to 20mm thick	-/90/30	-/120/30	300	
		Up to 50mm OD with FR insulation	-/90/30	-/120/30	300	
		Up to 20mm OD with 38mm rockwool-type insulation	-/90/30	-/120/30	300	
	Pair coil	Up to 9.5 & 19mm with 20mm FR insulation (or 13mm PE)	-/90/30	-/120/30	300	
Power Cables - Copper Core	TPS	Up to 12x 2.5mm ² per bundle	-/90/30	-/120/30	300	
	AS1530.4 Appendix D1 cable set	Applies to copper core power cables	-/90/30	-/120/30	600**	
Power Cables Aluminium Core	Single Core cables	Bundles of up to 3 x 240mm ² , 4 x 120mm ² and 9 x 70mm ² per bundle (16x cables total)	-/90/30	-/120/30	300	
Communications Cables	Fibre Optic Cable	NBN grade cable	-/90/30	-/120/30	300	
	RG6 coax	Up to 3x per bundle	-/90/30	-/120/30	300	
	AS1530.4 Appendix D2 cable set	Applies to copper core comms cables, including cable trays up to 1000mm wide	-/90/30	-/120/30	450	
Conduits	Rigid or Flexible PVC Conduits	Up to 32mm OD (with or without cables)	-/90/30	-/120/30	300	

TRAFALGAR COREX SHAFT WALLS

2x laminated Corex boards fixed to one side of a 64mm steel stud. FRL of the wall is related to thickness of the Corex facings as shown in the table. [Click here for the Corex Shaft Wall technical Manual.](#)



Service Type	Service Specification		Corex Board Specification & SuperSTOPPER® Penetration FRL*			TWrap Length required (mm)
			2x15mm	2x20mm	2x25mm	
Plastic Pipes	PVC Pipes	Up to 32mm OD				450
	PEX Pipes	Up to 20mm				450
		Up to 32mm				450
		Up to 32mm with 19mm E-Flex insulation				450
	PEX-Al-PEX pipes	Up to 20mm				450
		Up to 25mm				450
		Up to 32mm				450
		Up to 32mm with 19mm E-Flex insulation				450
cPVC Pipes	Up to 40mm	450				
	40mm to 60mm	450				
Bare Metal Pipes	Copper	Up to 50mm				450
	Steel	up to 60mm				450
Metal Pipes Insulated**	Copper	Up to 50mm OD with PE insulation up to 20mm thick	-/60/60	-/90/90	-/120/120	450
		Up to 50mm OD with FR insulation				450
	Up to 20mm OD with 38mm rockwool-type insulation	450				
	Pair coil	Up to 9.5 & 19mm with 13mm PE insulation				450
		Up to 9.5 & 19mm with 20mm FR insulation				450
Power Cables - Copper Core	TPS	Up to 12x 2.5mm ² per bundle				450
	AS1530.4 Appendix D1 cable set	Applies to copper core power cables and cable trays up to 1000mm wide				450
Power Cables Aluminium Core	Single Core cables	Bundles of up to 3 x 240mm ² , 4 x 120mm ² and 9 x 70mm ² per bundle (16x cables total)				450
Communications Cables	Fibre Optic Cable	NBN grade cable				450
	RG6 coax	Up to 3x per bundle				450
	AS1530.4 Appendix D2 cable set	Applies to copper core comms cables, including cable trays up to 1000mm wide				450
Conduits	Rigid or Flexible PVC Conduits	Up to 32mm OD (with or without cables)				450

For Corex walls, the wall must be thickened on one side with 100mm wide Maxilite, 60mm thick around the penetration.

*For specific service based FRL's without using TWrap, refer to report FC10266.

**Heat trace cables may be installed underneath thermal lagging through a SuperSTOPPER® penetration

2 HOUR FRL SLABS MINIMUM THICKNESS 120MM

Concrete floors with our without steel decks with an effective minimum thickness of 120mm.



Service Type	Service Specification		FRL – Wrap Free	FRL – With TWrap	TWrap Length (mm)
Blank (No Ser-	20x20mm Fillet of Fyreflex Sealant applied to perimeter of SuperSTOPPER® Cast In (not required when TWrap applied)		-/120/120	Wrap Free	N/a
Plastic Pipes	PEX pipes	up to 32mm OD	-/120/-	-/120/120	450
	PEX-Al-PEX pipes	up to 32mm OD	-/120/-	-/120/120	450
	PVC pipes	up to 80mm OD	-/120/-	-/120/120	300
Bare Metal Pipes	Copper pipes	up to 42mm OD	-/120/-	-/120/120	450
		up to 100mm OD	-/120/-	-/120/120	600 1 st Layer + 450 2 nd Layer [^]
	Steel pipes	up to 50mm OD	-/120/-	-/120/120	450
		up to 100mm OD	-/120/-	-/120/120	600 1 st Layer + 450 2 nd Layer [^]
Metal Pipes Insulated*	Copper pipes	up to 50mm OD with FR insulation	-/120/60	-/120/120	300
	Stainless Steel pipes	Up to 50mm OD with EPS or PE insulation and rockwool	-/120/60	-/120/120	300
	Pair Coils	Up to 9.5 & 19mm with up to 20mm FR insulation (OR 13mm PE) with 10mm OD cable	-/120/60	-/120/120	450
Power Cables - Aluminium Core	Single core AL cables	Up to 4 x 240mm ² single core + optional 120mm ² earth cable	-/120/30	-/120/120	450**
		Up to 1x 400mm ²	-/120/30	-/120/120	450**
	4x Core AL cables	Up to 4 x 16mm ² 4C + E cables	-/120/30	-/120/120	450**
Power Cables	TPS cables	Up to 10x per bundle	-/120/60	-/120/120	300
	3x Core cables	19mm diam 3C + E cables	-/120/60	-/120/120	300
	AS1530.4 Appendix D cable set (no cable tray)	Applies to all copper core power cables	-/120/30	-/120/120	600 (min. 190mm slab)
Comms Cables	AS1530.4 Appendix D cable sets	Copper core comms cables	-/120/60	-/120/120	450 (Min.190mm slab) Or 600mm
	Fibre Optic cables	NBN grade cable	-/120/30	-/120/120	300
	CAT6	Up to 150x per bundle	-/120/60	-/120/120	300
Conduits	uPVC Conduits Rigid or Flexible	Up to 32mm OD (with or without cables)	-/120/60	-/120/120	300
Drinks python***	Lagged post mix lines	90mm OD 10x post mix lines with 19mm FR thermal lagging	-/120/120	-/120/120	Wrap Free

[^]Large metal pipes require 2 layers of TWrap. Refer to [page 22](#)

*With or without heat trace cable

**SuperSTOPPER foam installed top and bottom

***Applies to SuperSTOPPER®-R-150 only.

3-4 HOUR FRL SLABS MINIMUM THICKNESS 175MM

Concrete floors with our without steel decks with an effective minimum thickness of 175mm.



Service Type	Service Specification		FRL – Wrap Free	FRL – With TWrap	TWrap Length (mm)
Metal Pipes	Steel Pipes	Up to 50mm	-/120/-	-/240/120	450
Insulated Metal Pipes	Stainless Steel Pipes	Up to 50mm OD with EPS or PE insulation and rockwool	-/240/60	-/240/240	300
Power Cables	3x Core	Up to 2x 19mm 3C + E per bundle	-/240/60	-/240/120	300
Comms Cables	CAT6	Up to 5x per bundle	-/240/60	-/240/120	300
Power Cables - Aluminium Core	Single core AL cables	Up to 1x 400mm ²	N/a	-/180/180*	300
Drinks python***	Lagged post mix lines	90mm OD 10x post mix lines with 19mm FR thermal lagging	-/240/240	-/240/240	Wrap Free

Where TWRAP is required for increased insulation performance, it is to be installed on top side of the slab. FyreWrap® Elite 1.5 may be substituted for any of the above TWRAP applications.

*Contact Trafalgar before use.

***Applies to SuperSTOPPER®-R-150 only.

THE CHALLENGE WITH 3-4 HOUR FRL'S

After two hours of the AS1530.4 fire test, the temperatures inside the furnace will increase from 1050 to 1200 degree's C which is above the melting points of some metals like copper. Therefore, most copper based building services (cables and copper pipes) are practically very difficult to remain under the insulation (heat rise) criteria past 2 hours.

In this case, please refer to our specific **3-4 hour FRL Applications Manual** for specific advice on how fire engineering can deal with these penetrations as an alternate solution to address the building code's performance requirements.

[Click Here](#)

[Download 3-4 Hour Penetrations Applications Manual](#)

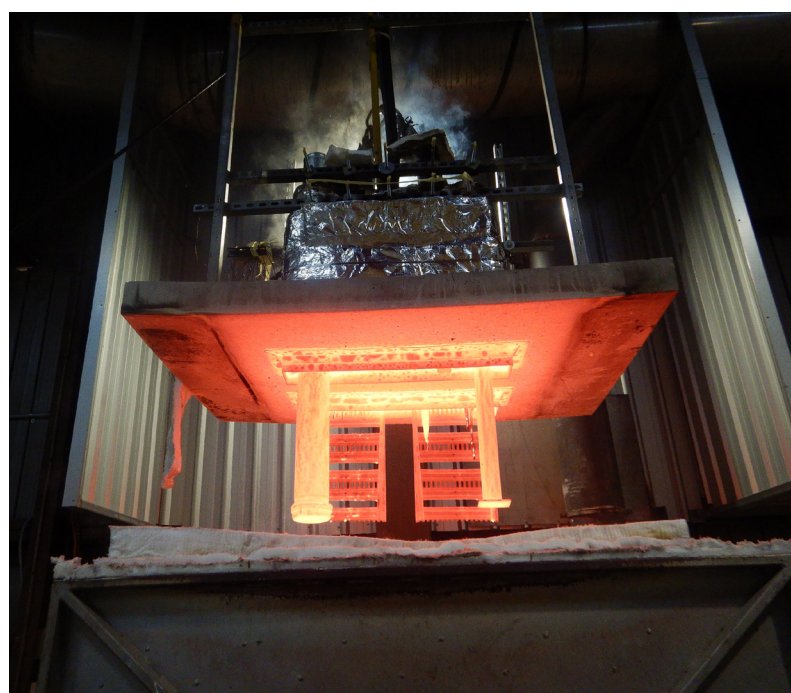

FIRE RATED CEILINGS

The SuperSTOPPER® systems are tested and approved for use in various ceilings including Corex board and plasterboard ceilings that meet the requirements listed. Penetrations MUST be lined with 60mm Maxilite board as shown in the installation drawings.

Timber or steel framed ceiling construction

Ceiling facing thickness	FRL	RISF
Minimum thickness 16mm	-/30/30	30mins
Minimum thickness 29mm	-/60/60	60mins
Minimum thickness 32mm	-/90/90	60mins
Minimum thickness 48mm	-/120/120	60mins

The FRL's listed below against service penetrations are limited to the FRL and RISF rating of the ceiling system they are installed into.

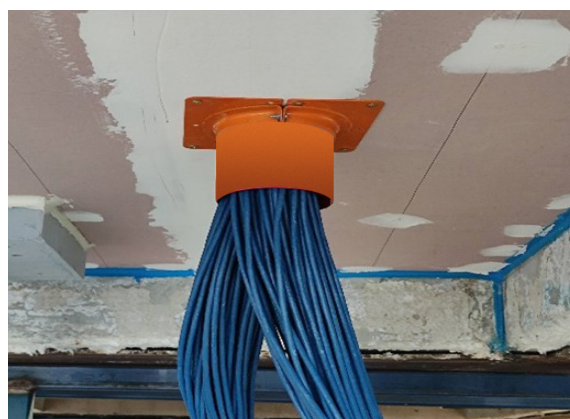

Service Type	Service Specification		FRL – Wrap Free	RISF – With TWrap	TWrap Length (mm)
Plastic Pipes	PEX pipes	up to 32mm OD	-/120/120	-/120/120	300
	PEX-Al-PEX pipes	up to 32mm OD	-/120/120	-/120/120	300
	PVC pipes	up to 80mm OD	-/120/120	-/120/120	300
Bare Metal Pipes	Copper pipes	up to 42mm OD	-/120/-	-/120/120	300
		up to 100mm OD	-/120/-	-/120/120	600
	Steel pipes	up to 50mm OD	-/120/-	-/120/120	300
		up to 100mm OD	-/120/-	-/120/120	600
Metal Pipes Insulated*	Copper pipes	up to 50mm OD with FR insulation	-/120/120	-/120/120	300
	Stainless Steel pipes	Up to 50mm OD with EPS or PE insulation and rockwool	-/120/120	-/120/120	300
	Pair Coils	Up to 9.5 & 19mm with up to 20mm FR insulation (OR 13mm PE) with 10mm OD cable	-/120/120	-/120/120	300
Power Cables - Aluminium Core***	4x Core AL cables	Up to 4 x 240mm ² + optional 90mm ²	-/90/30	-/90/90	300
	Single core AL cables	Up to 1x 400mm ²	-/90/30	-/90/90	300
Power Cables - Copper Core	TPS cables	Up to 10x per bundle	-/120/120	-/120/120	300
	3x Core cables	19mm diam 3C + E cables	-/120/120	-/120/120	300
	AS1530.4 Appendix D cable sets on cable trays	Applies to all copper core power cables and cable trays up to 1000mm wide	-/120/30	-/120/120	600
Comms Cables	AS1530.4 Appendix D cable sets on cable trays	Copper core comms cables and cable trays up to 1000mm wide	-/120/30	-/120/120	450
	Fibre Optic cables	NBN grade cable	-/120/120	-/120/120	300
	CAT6	Up to 150x per bundle	-/120/120	-/120/120	300
Conduits	uPVC Conduits Rigid or Flexible	Up to 32mm OD (with or without cables)	-/120/120	-/120/120	300

INSTALLATION SuperSTOPPER® in Walls

ALL WALLS

CUT HOLE



Cut a hole in the barrier allowing for an appropriate annular gap (5-20mm between the edge of the hole and the walls of the SuperSTOPPER®). Example: for a 100mm SuperSTOPPER®-R, cut a maximum hole 140mm diameter.

Note SuperSTOPPER®s do not require openings to be framed with stud or lined with plasterboard.

INSERT AND SEAL



Insert the SuperSTOPPER® into the hole, and centre it to the wall or floor. NOTE: if barrier is too thick, contact Trafalgar Fire for alternative installations.

Seal the annular gap around the SuperSTOPPER® with FyreFLEX® Sealant to 20mm depth, on both sides of the wall.

Please note: The SuperSTOPPER® can be installed before or after the services are in place, the hinged design allows for the box to be retro fit around services, or services can be run once the box is in place.

FLANGES

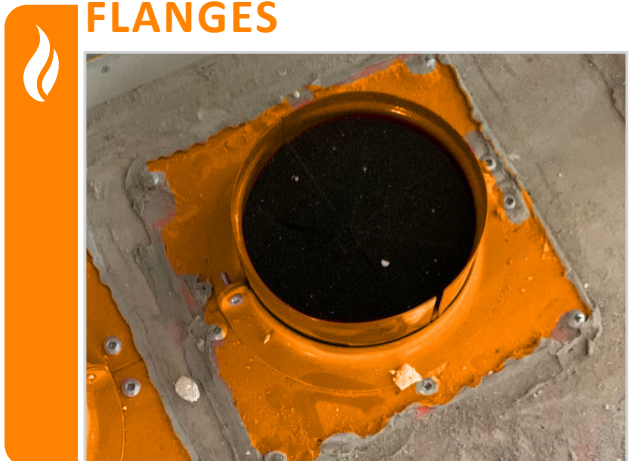

Install the steel mounting flange to both sides of the wall, or just the **top side** of a concrete floor. When fitting the orange flanges, use the fixings to suit the wall or floor type as per table 1 on [page 24](#), using 2x fixings per flange.

FOAM



Cut a slit through the SuperSTOPPER® foam plug inserts and notch out holes to suit the services that are installed, then fit the foam in the box around the services. Foam is needed on both sides of a wall, but only the **top side** of a concrete slab penetration.

The fit should be snug, fill any gaps with intumescent

Click to Watch Installation Video



INSTALLATION SuperSTOPPER® in Walls

ALL WALLS



TWRAP

Where required, wrap the services with the appropriate length of TWRAP (per FRL tables above). The TWRAP should overlap itself around the pipe by 50mm, if two strips are required to meet the appropriate length, then where the second length meets the first, a 50mm overlap is required.

TWRAP is secured to the service using steel cable ties, 50mm from each end and 150mm centres in-between.



LABELLING

Document the penetration. It is general good practice to take photographs and label all completed penetration works to add to the site's documentation for future inspections. AS4072 includes some recommendations and templates for penetration register stickers.

If you need penetration stickers, we offer them at Trafalgar. Click [here](#).

TABLE 1: FIXINGS SuperSTOPPER® Maxi & Mini

Wall Type	Fixing
Plasterboard walls, Corex and shaft walls	8gx50mm plasterboard screws
AAC panel (Hebel®, Walsc® etc)	
FyreBOARD Maxilite®	
Speedpanel®	8gx50mm metal drilling head screws
Concrete/Masonry and Alpha Panel	M6x50mm masonry anchors
Plasterboard Ceilings	10gx 100mm plasterboard screws, and additional framing (refer to page 30-31)

INSTALLATION SuperSTOPPER®

CEILINGS



CUT HOLE

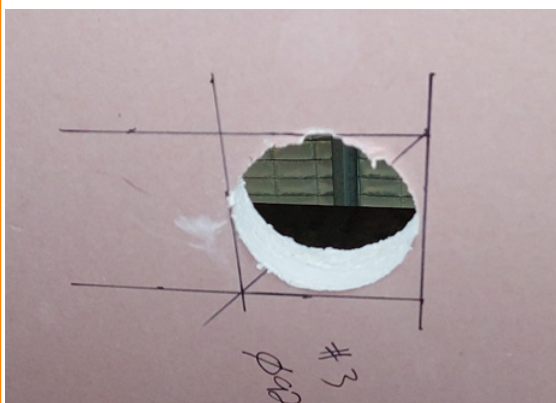

Cut the appropriately sized hole in the ceiling (5-20mm annular gap). SuperSTOPPER® can be unhinged to fit around existing services.



THICKEN

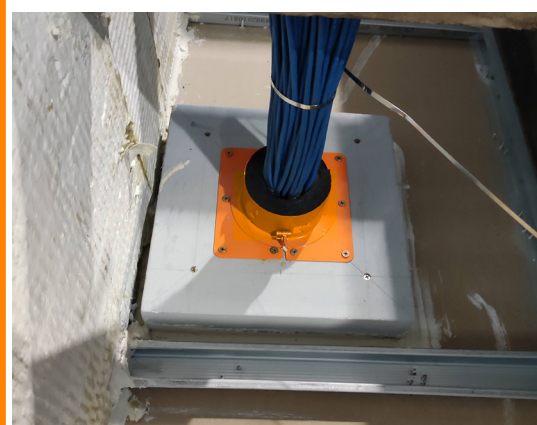

Install 60mm thick Maxlite board to the top side of the penetration around the SuperSTOPPER® with 100mm overlaps on all sides. Fix in place with 10x100mm screws.

Please note: When cutting a hole in any floor for a SuperSTOPPER®, allow for a 5-20mm gap between the box and the edge of the hole.



FLANGES

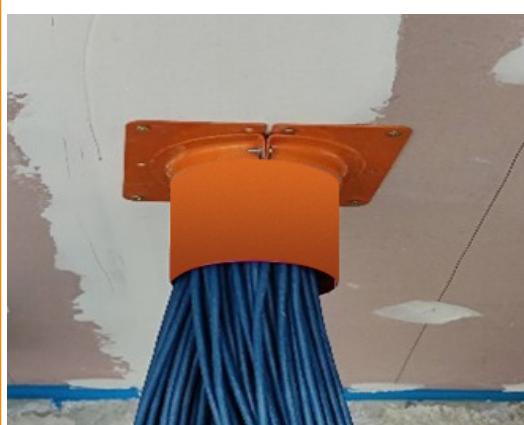

Seal the gaps with FyreFLEX sealant and install both the upper and lower flanges, fixing in place with 10x100mm screws.



FOAM

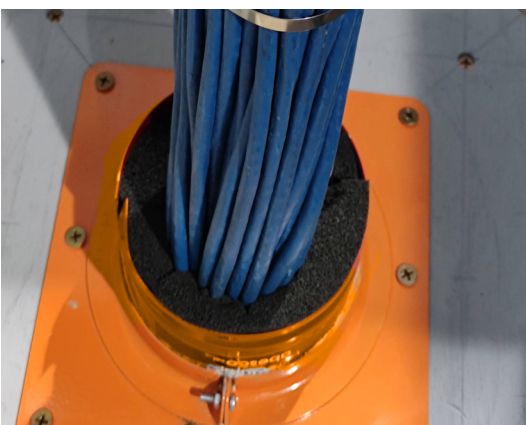

Cut a slit through the SuperSTOPPER® foam plug inserts and notch out holes to suit the services that are installed, then fit the foam in the box around the services on the top side only.

The fit should be snug, fill and gaps with foam off-cuts or FyreFLEX® Sealant.

INSTALLATION PROBLEM SOLVER

FyreBOARD Maxilite® PENETRATIONS



BULKHEADS

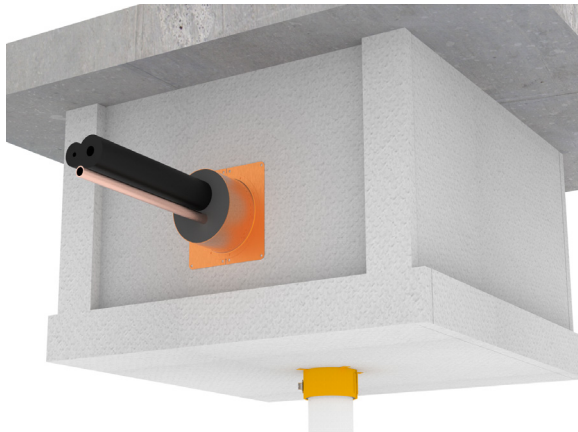

Where it is not possible to treat penetrations directly at the wall/floor penetration, SuperSTOPPER® systems are compatible with FyreBOARD Maxilite® bulkhead systems. Refer to [FyreBOARD Maxilite®](#) technical manuals for more information. For compliance of Maxilite bulkhead systems please refer to report FCO2586.

Please note: All penetrations using FyreBOARD Maxilite® require at least 60mm thickness of board.

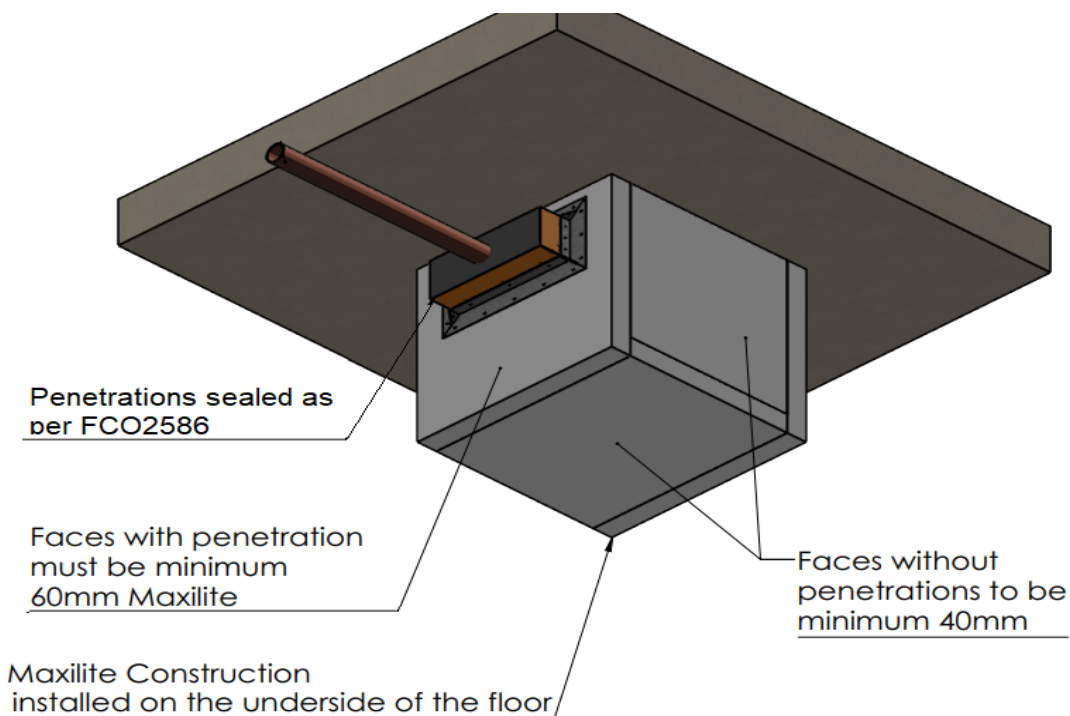

SUPERSTOPPER®



COMPLIANCE WITH THE NATIONAL CONSTRUCTION CODE (NCC)

Formerly known as BCA

Under the NCC requirements, a multiple service transit system for service penetrations should be fire tested in every configuration that it is intended for use in, both completely empty (blank seal), partially full and completely full of services so that the product may be installed with as many or as little services as required on site. It is important to fire test in all the different walls types and with different configurations, quantities and types of services which is a time consuming (and expensive) exercise.

Trafalgar Fire SuperSTOPPER systems have been fire tested extensively to AS1530.4-2014 and approved in accordance with Section 4 AS4072.1 as required by Schedule 5 of the NCC. This includes over 200 hours of accredited furnace time and 30 plus individual test reports to cover the full range of service and wall configurations that allow us to comfortably stand behind our multiple SYSTEM approvals.

These configurations include but are not limited to:

- Service fill ratio: Empty (blank seal), half full and completely full of services
- Barrier types: Various types of plasterboard, concrete, Blockwork, Hebel®, Walsc®, Speedpanel®, Pronto panel, FyreBOARD Maxilite® board, concrete floors etc
- Services: Bare and insulated metal pipes and cable bundles, AL and Cu core cables, PVC pipes & conduits, PEX and PEX-AL-PEX pipes, CPVC pipes etc
- Configurations: Blank seal (empty), full of services, double stacked, side by side etc
- Insulation performance: Tested both wrapped and unwrapped with TWRAP to ensure the system works in both configurations
- Penetration sizes: 150 x 125, 350x125, 550x125, 1100x125
- SuperSTOPPER® Variants: Slab Mount, Slab Mount Bambino, Cast-in, Maxi and SuperSTOPPER (retrofit)

When choosing a multiple service transit penetration system like SuperSTOPPER®, it is important to check that all aspects of your system have been fire tested and are fit for purpose.

Compliance will only be achieved when the installation on site mirrors the tested system.

TEST AND ASSESSMENT REPORTS

The above-mentioned fire testing reports have all been conveniently summarised into **BRANZ assessment report FC10266 (available on www.tfire.com.au)** which neatly tabulates the approved services in a range of fire barriers, for all SuperSTOPPER® and SuperSTOPPER variants and applications, and covers only minor variations to the tested systems, thereby providing trouble free certification according to NCC.

Importantly, every aspect of the assessment report are backed up by the fire test data and the individual fire test reports are available on request for certification purposes.

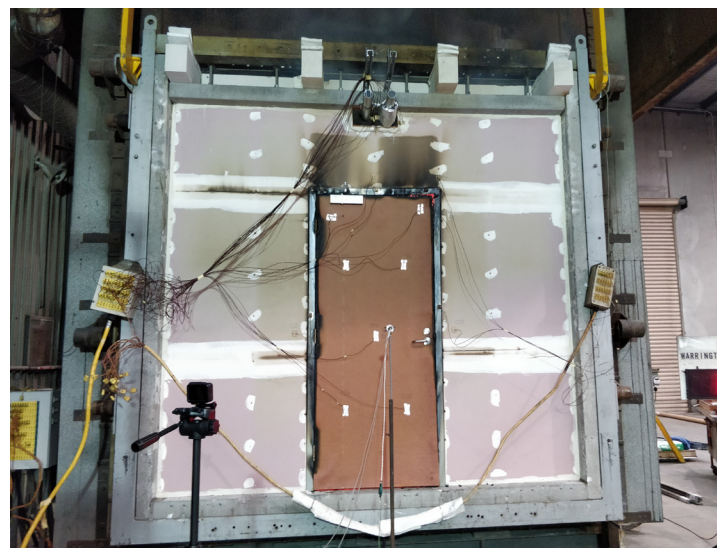

FAQ

Q Is the SuperSTOPPER® suitable for my refrigeration lines?

A Yes, the SuperSTOPPER® has been tested with both fire resistant (FR) and non-FR insulation and can be filled with as many lines as will reasonably fit in the box.

Q Can I install a SuperSTOPPER® after the services have been installed?

A Yes, the SuperSTOPPER® has a hinged panel allowing for a retrofit option.

Q My opening is 300 x 600mm. Can I still use a SuperSTOPPER®?

A Yes, the opening can be sealed off with Trafalgar Fire's fire rated [FyreBOARD Maxilite®](#) board, and SuperSTOPPER® can be mounted in the board. Contact Trafalgar Fire for installation details.

Q My certifier told me I need 2-hour insulation rating on my copper pipe penetrations – does the SuperSTOPPER® achieve this?

A TWRAP (or FyreWrap®) will need to be wrapped around the SuperSTOPPER® to achieve an insulation rating. Contact Trafalgar Fire for installation details and refer to our YouTube channel for installation videos (Trafalgar TV).

Q Do I need to separate my pipes and cables inside the SuperSTOPPER?

A No, the SuperSTOPPER® Range has been fire tested completely full and empty (some trade specific separation may be required).

Q How close together can two SuperSTOPPER® be?

A 100mm apart.

Q How far apart other service penetrations need to be from the SuperSTOPPER?

A The NCC references AS 1530.4 2014 which requires 200mm of separation between penetrations during a fire test. Consult your site certifier or surveyor for any reductions on your specific site.



Click to Watch Installation





Click to Watch Installation Video



SOCIAL MEDIA



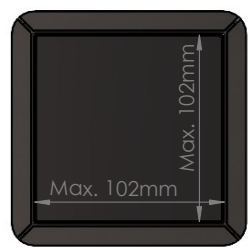
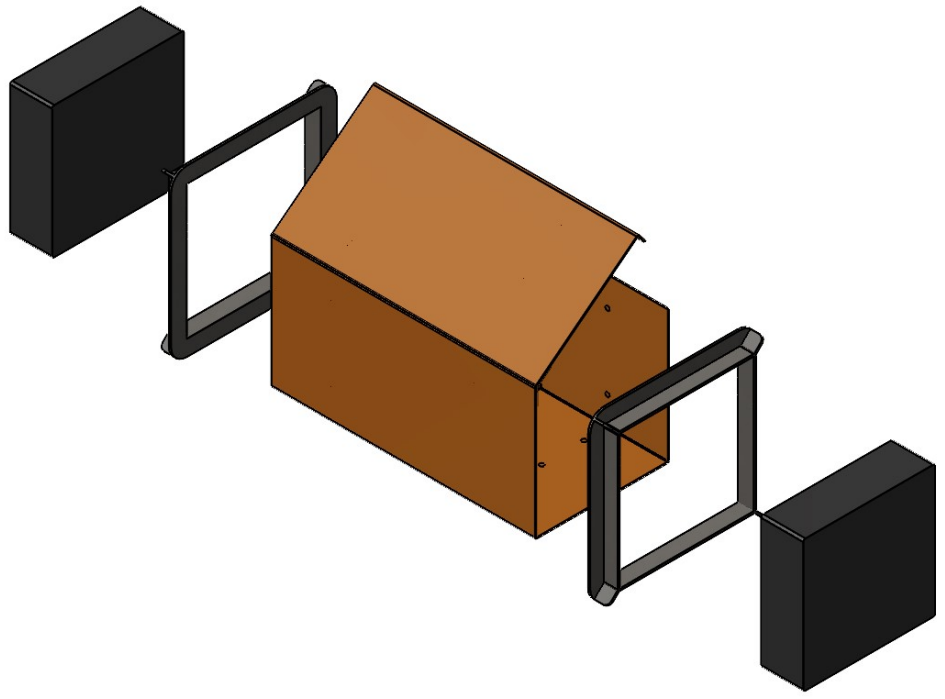
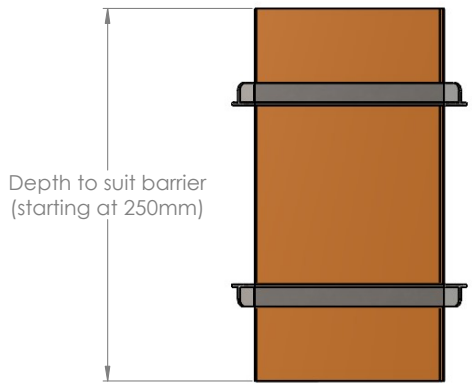

SuperSTOPPER Mini - Product Overview



SuperSTOPPER Mini Square



SuperSTOPPER Mini Round

Drawing Name: Overview				Test Standard: AS1530.4	Codes:	Revision:	Date:	No.:	NOTICE:
Drawing Title: SuperSTOPPER Mini -Generic Install				Fire resistance level:	Drawn By: JC				NOTE: ALL DIMENSIONS ARE IN MILLIMETRES (mm)
Drawing No. : 1	Sheet: 1 of 13	Date: 10/05/2024	Scale: NTS	Based on Report No.:	Checked By: CT	<input type="checkbox"/> STANDARD DRAWING <input type="checkbox"/> PROJECT DRAWING		 Trafalgar Head Office: PO BOX 545 Chester Hill NSW 2162 T: 1800 888 714 F: 1800 201 500 E: info@tfire.com.au W: www.tfire.com.au	

SuperSTOPPER Mini (Round or Square) - Annular Gaps

Standard Flange
Up to 5mm annular gaps

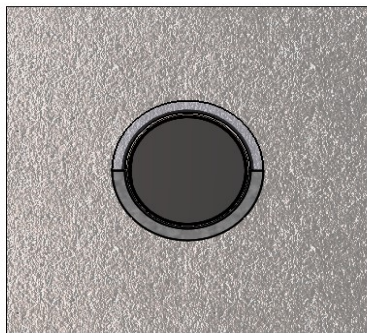
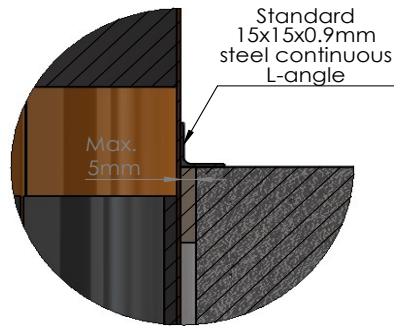

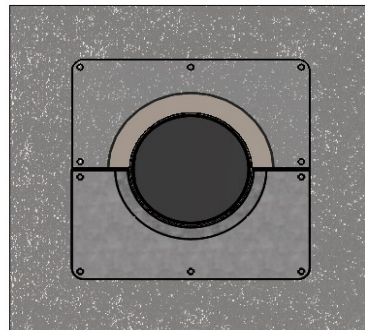
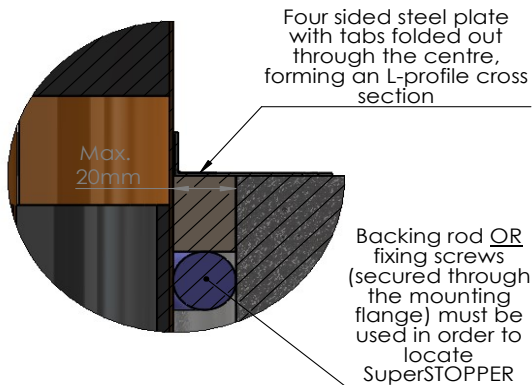

Updated Flange
Up to 20mm annular gaps

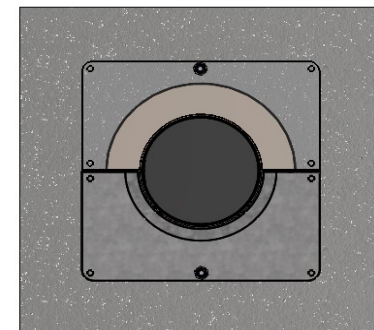
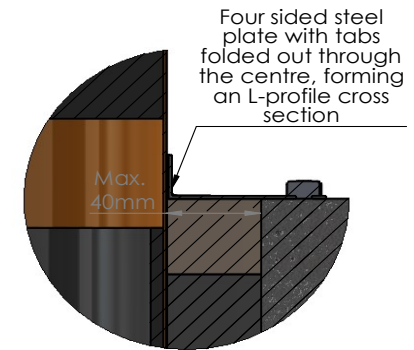

Enlarged Updated Flange
Up to 40mm annular gaps*

*Must follow additional details as outlined in the "Oversized / Scalloped Openings" drawing of this report



Drawing Name: Annular Gaps				Test Standard: AS1530.4	Codes:	Revision:	Date:	No.:	NOTICE:
Project Title: SuperSTOPPER Mini -Generic Install				Fire resistance level:	Drawn By: JC	<small>NOTE: ALL DIMENSIONS ARE IN MILLIMETRES (mm)</small>  Trafalgar Head Office: PO BOX 545 Chester Hill NSW 2162 T: 1800 888 714 F: 1800 201 500 E: info@tfire.com.au W: www.tfire.com.au			
Drawing No. : 2	Sheet: 2 of 13	Date: 10/05/2024	Scale: NTS	Based on Report No.:	Checked By: CT				

SuperSTOPPER Mini (Round or Square) - Installation Overview

STEP 1

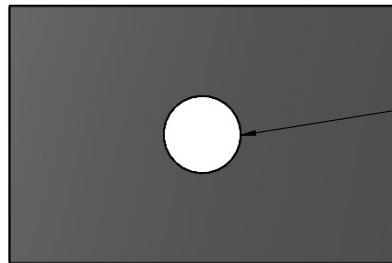

Approved wall/floor opening

Form opening so that annular gaps between SuperSTOPPER Mini and wall/floor will not exceed 20mm

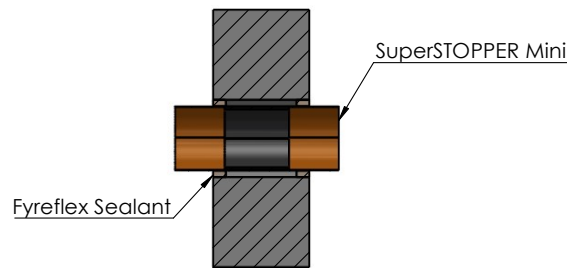

Insert SuperSTOPPER Mini into opening so that it is central to the thickness of the wall/floor. Fill annular gaps with Fyreflex Sealant to a depth of at least 20mm from each side of the barrier.

STEP 3

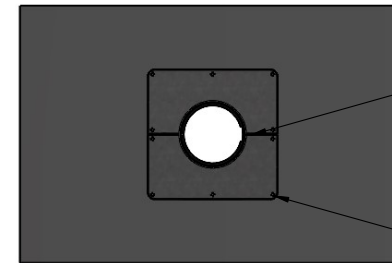

SuperSTOPPER Mounting Flanges

Fixings as required for oversized flanges

Fit mounting flanges (as per 'SuperSTOPPER Mini Mounting Flanges' drawing) around SuperSTOPPER, from each side of the wall/floor, clamping SuperSTOPPER in place. Secure using the clamping method or optional fixings as required

STEP 4

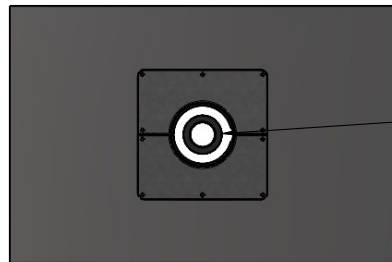

Approved services can be run at any step of the install

Run approved services through the SuperSTOPPER opening. Please note, the SuperSTOPPER Mini has a hinged lid and is also suitable for retrofitting around existing services

STEP 5

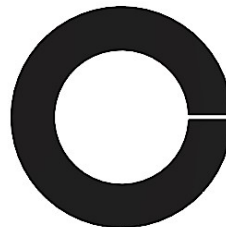

Retrieve foam end plugs and form openings to match the services within the SuperSTOPPER. Cutting a slit through these openings will allow for the plug to be opened and inserted around the existing services

STEP 6

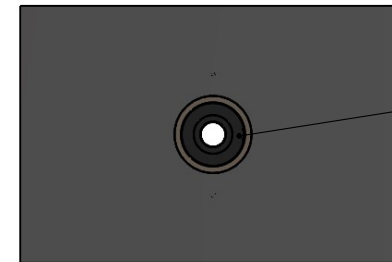

Foam end plugs fit snug around services

Fit foam end plugs tightly around the services, from each side of the SuperSTOPPER, and plug any gaps with foam off cuts or Fyreflex/Fyrepex Sealant. Continue to 'TWrap' drawing if wrapping will be required for full insulation.

NOTE: This is a generic installation guide. For specific details relative to each barrier type, please refer to the corresponding installation drawing as follows.

Drawing Name: Installation Overview				Test Standard: AS1530.4	Codes:	Revision:	Date:	No.:	NOTICE:
Project Title: SuperSTOPPER Mini -Generic Install				Fire resistance level:	Drawn By: JC	<small>NOTE: ALL DIMENSIONS ARE IN MILLIMETRES (mm)</small>  Trafalgar Head Office: PO BOX 545 Chester Hill NSW 2162 T: 1800 888 714 F: 1800 201 500 E: info@tfire.com.au W: www.tfire.com.au			
Drawing No. : 3	Sheet: 3 of 13	Date: 10/05/2024	Scale: NTS	Based on Report No.:	Checked By: CT				

Concrete / Masonry Walls (with or without permanent formwork)

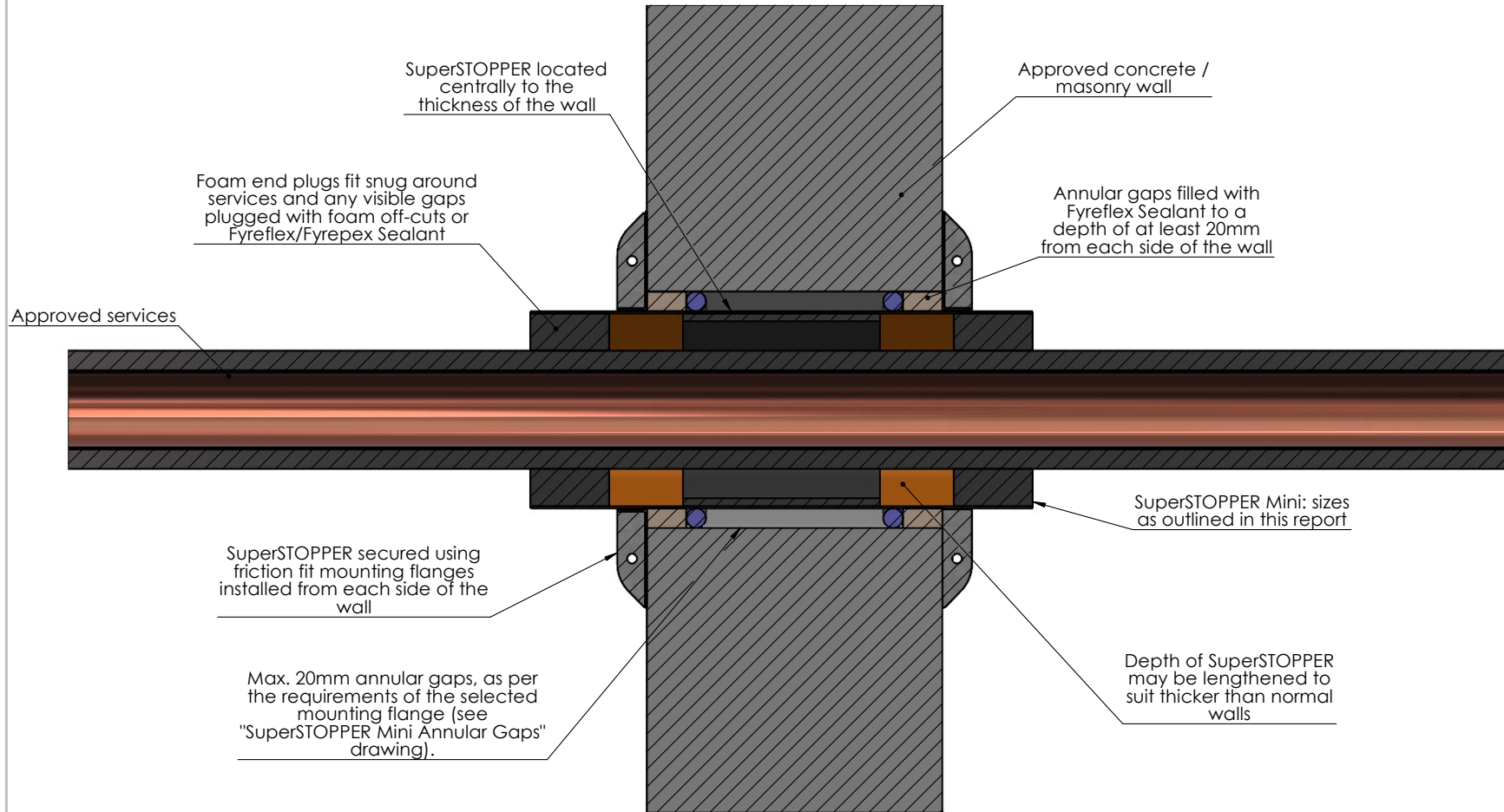

Drawing Name: Concrete / Masonry Wall				Test Standard: AS1530.4	Codes:	Revision:	Date:	No.:	NOTICE:
Project Title: SuperSTOPPER Mini -Generic Install				Fire resistance level:	Drawn By: JC	<small>NOTE: ALL DIMENSIONS ARE IN MILLIMETRES (mm)</small>  Trafalgar Head Office: PO BOX 545 Chester Hill NSW 2162 T: 1800 888 714 F: 1800 201 500 E: info@tfire.com.au W: www.tfire.com.au			
Drawing No. : 4	Sheet: 4 of 13	Date: 10/05/2024	Scale: NTS	Based on Report No.:	Checked By: CT				

Plasterboard Walls and Shafts - Plasterboard lined on each side

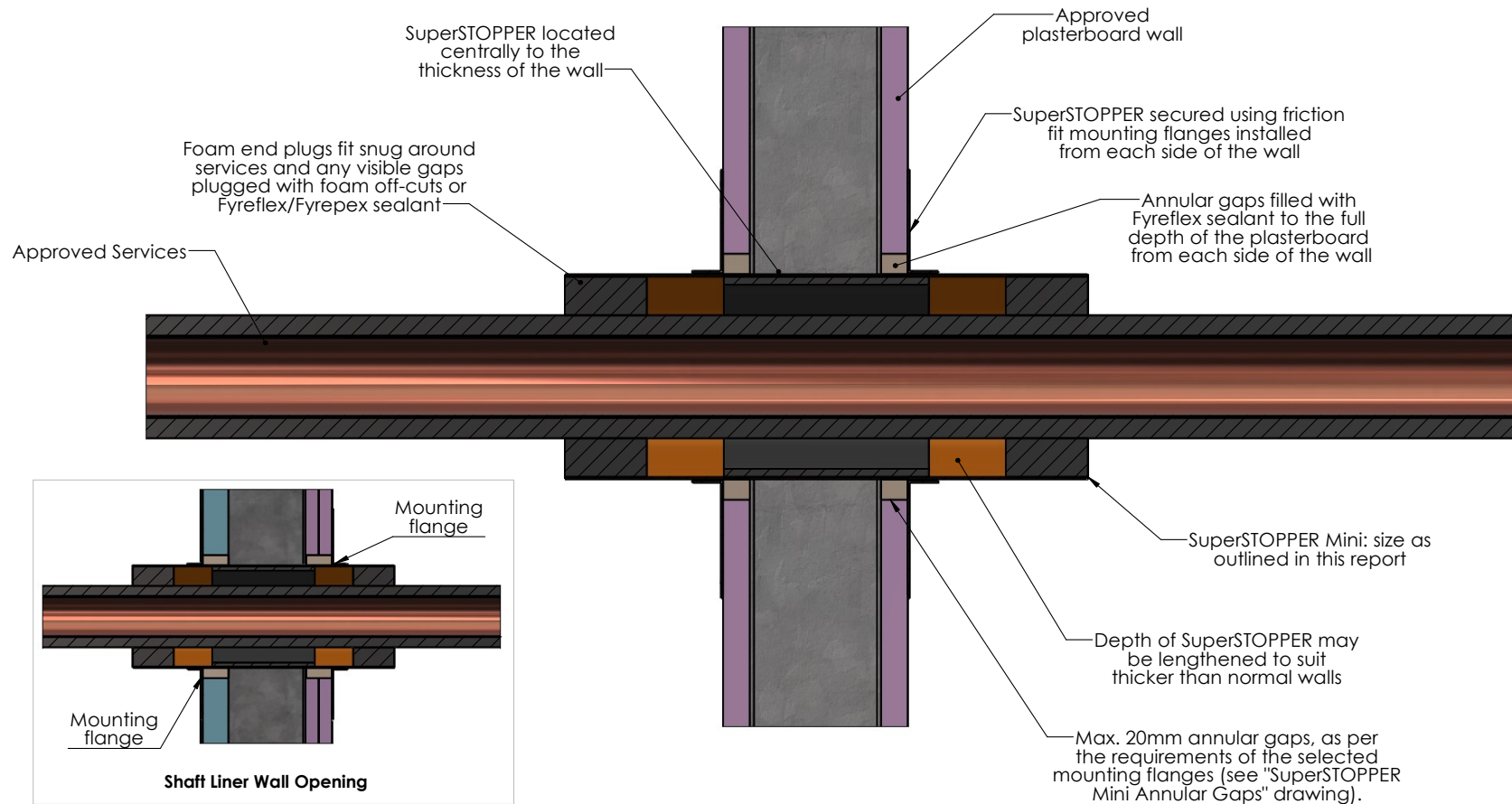

Drawing Name: Plasterboard - Lined Each Side				Test Standard: AS1530.4	Codes:	Revision:	Date:	No.:	NOTICE:
Project Title: SuperSTOPPER Mini -Generic Install				Fire resistance level:	Drawn By: RH	<small>NOTE: ALL DIMENSIONS ARE IN MILLIMETRES (mm)</small>  Trafalgar Head Office: PO BOX 545 Chester Hill NSW 2162 T: 1800 888 714 F: 1800 201 500 E: info@tfire.com.au W: www.tfire.com.au			
Drawing No. : 5	Sheet: 5 of 13	Date: 10/05/2024	Scale: NTS	Based on Report No.:	Checked By: JH				

Plasterboard Walls and Shafts - Plasterboard lined on one side

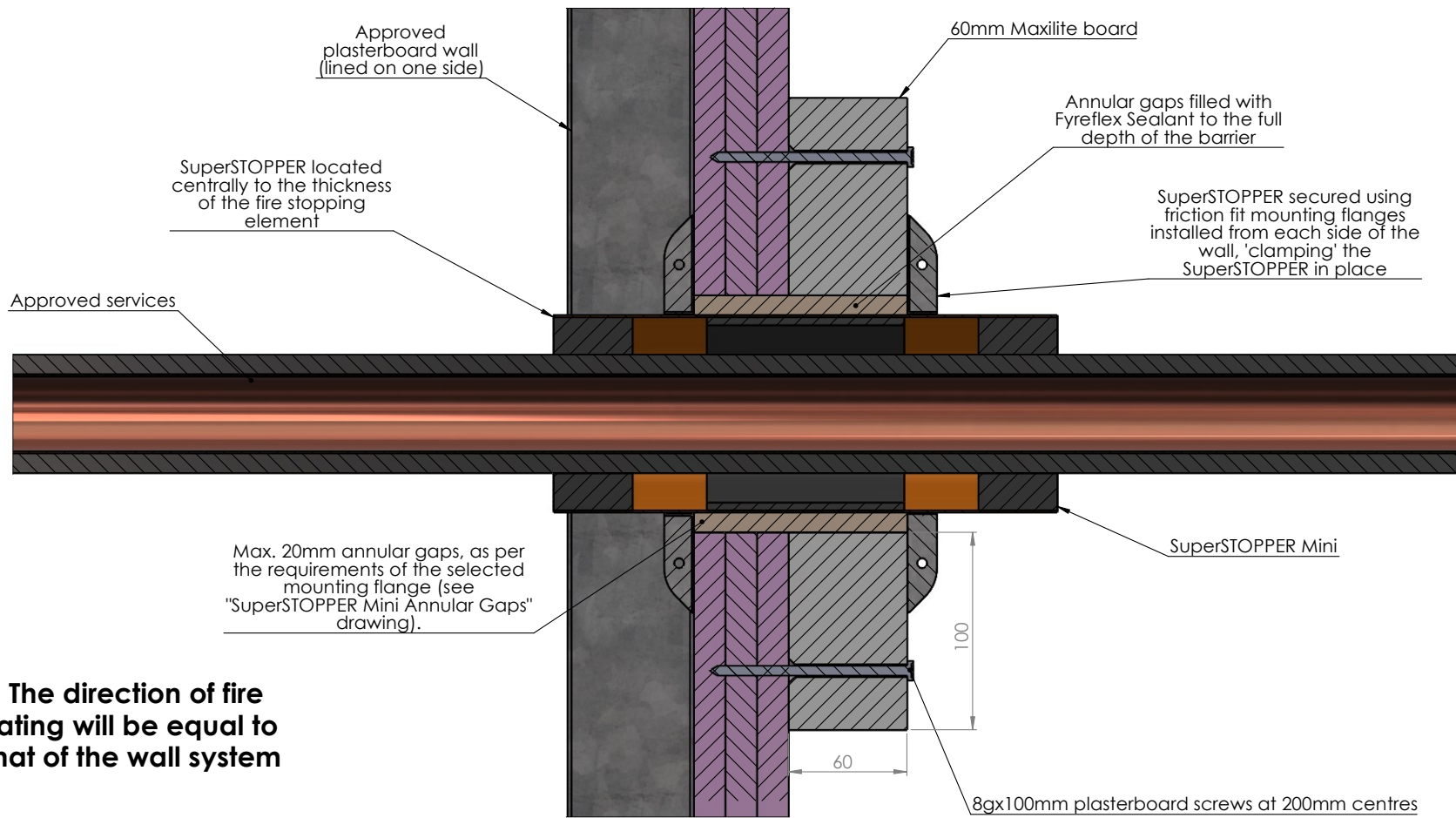

NOTE: If TWrap is to be applied for full insulation, it will only be required in the direction of the fire rating

Drawing Name: Plasterboard - Lined One Side				Test Standard: AS1530.4	Codes:	Revision:	Date:	No.:	NOTICE:
Project Title: SuperSTOPPER Mini -Generic Install				Fire resistance level:	Drawn By: JC	<small>NOTE: ALL DIMENSIONS ARE IN MILLIMETRES (mm)</small>  Trafalgar Head Office: PO BOX 545 Chester Hill NSW 2162 T: 1800 888 714 F: 1800 201 500 E: info@tfire.com.au W: www.tfire.com.au			
Drawing No. : 6	Sheet: 6 of 13	Date: 10/05/2024	Scale: NTS	Based on Report No.:	Checked By: CT				

Hebel/Walsc AAC Walls

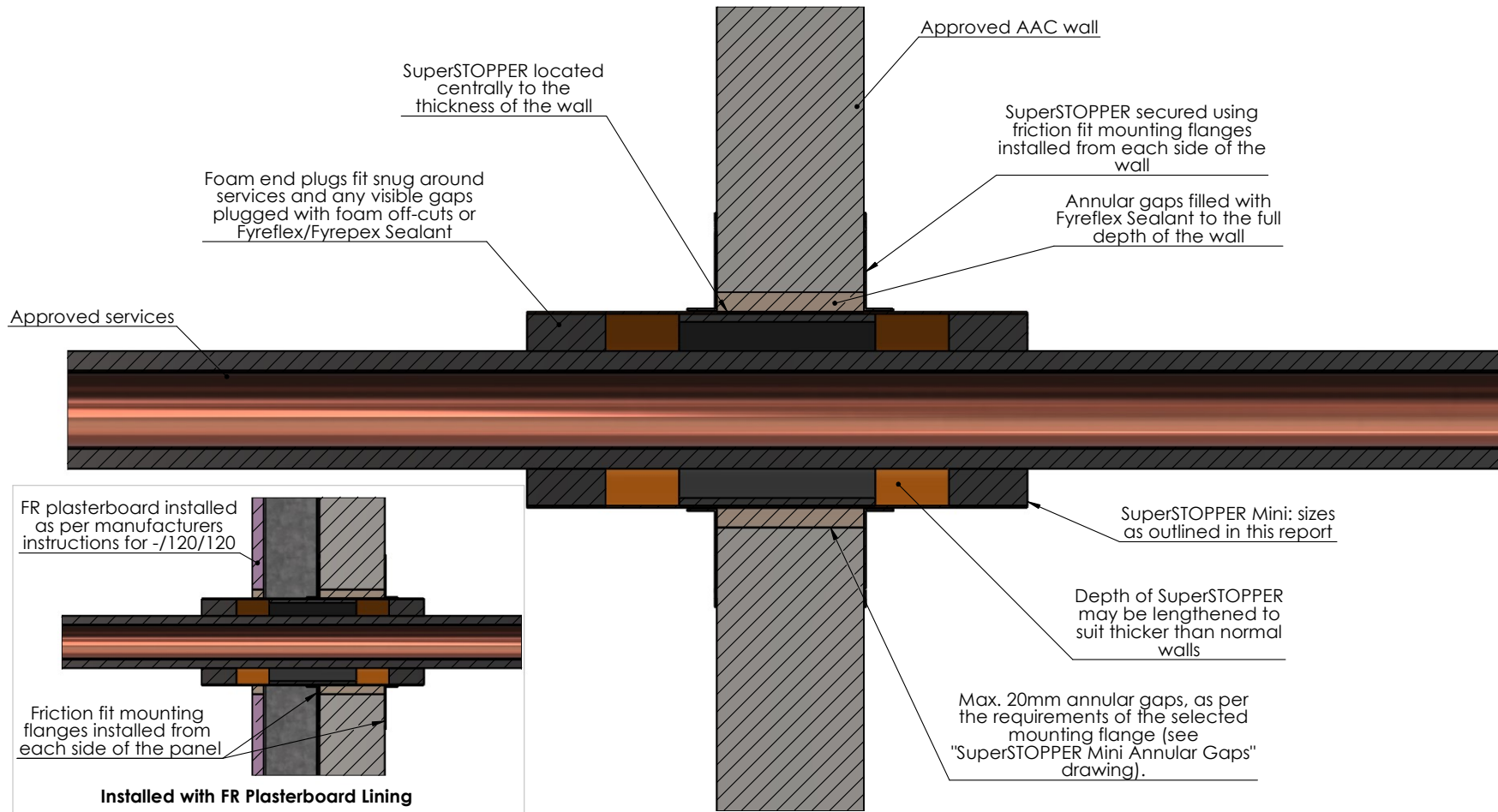

Drawing Name: Hebel/Walsc AAC				Test Standard: AS1530.4	Codes:	Revision:	Date:	No.:	NOTICE:
Project Title: SuperSTOPPER Mini -Generic Install				Fire resistance level:	Drawn By: JC	<small>NOTE: ALL DIMENSIONS ARE IN MILLIMETRES (mm)</small>  Trafalgar Head Office: PO BOX 545 Chester Hill NSW 2162 T: 1800 888 714 F: 1800 201 500 E: info@tfire.com.au W: www.tfire.com.au			
Drawing No. : 7	Sheet: 7 of 13	Date: 10/05/2024	Scale: NTS	Based on Report No.:	Checked By: CT				

Speedpanel Walls

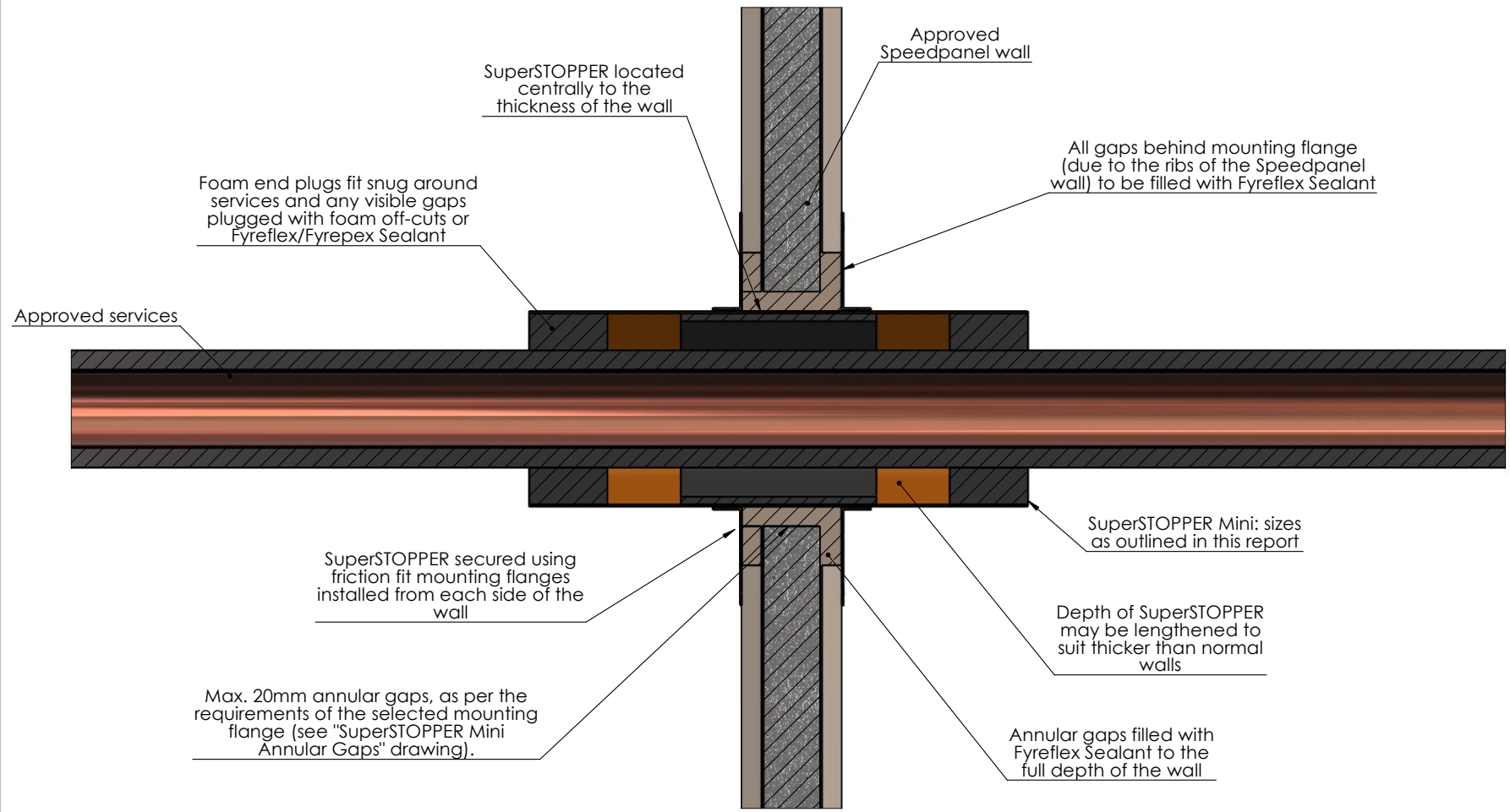

Drawing Name: Speedpanel				Test Standard: AS1530.4	Codes:	Revision:	Date:	No.:	NOTICE:
Project Title: SuperSTOPPER Mini -Generic Install				Fire resistance level:	Drawn By: JC				<small>NOTE: ALL DIMENSIONS ARE IN MILLIMETRES (mm)</small>  Trafalgar Head Office: PO BOX 545 Chester Hill NSW 2162 T: 1800 888 714 F: 1800 201 500 E: info@tfire.com.au W: www.tfire.com.au
Drawing No. : 8	Sheet: 8 of 13	Date: 10/05/2024	Scale: NTS	Based on Report No.:	Checked By: CT	<input type="checkbox"/> STANDARD DRAWING <input type="checkbox"/> PROJECT DRAWING			

Speedpanel Walls 51mm and 64mm thick

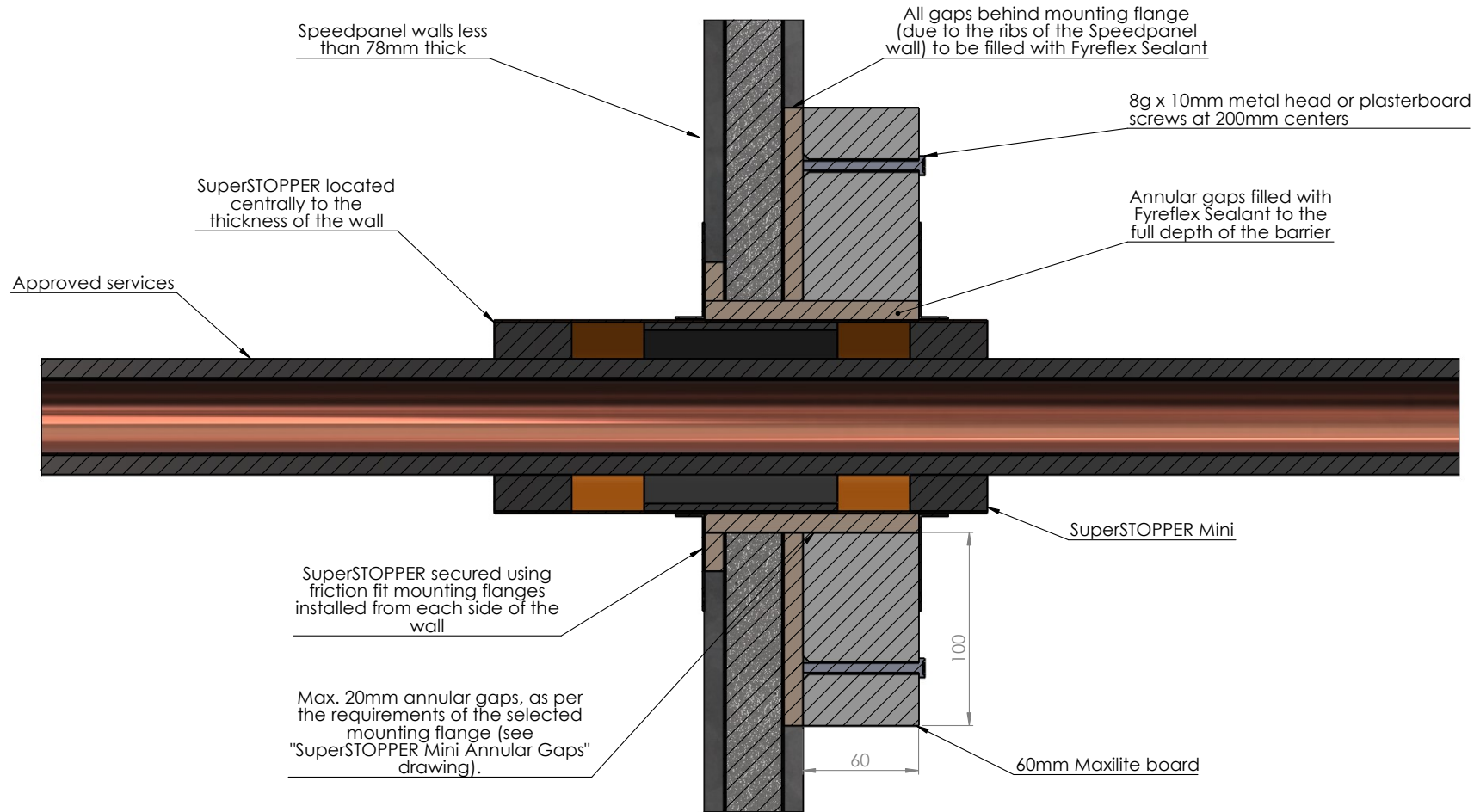

Drawing Name: Speedpanel <78mm				Test Standard: AS1530.4	Codes:	Revision:	Date:	No.:	NOTICE:
Project Title: SuperSTOPPER Mini -Generic Install				Fire resistance level:	Drawn By: JC				<small>NOTE: ALL DIMENSIONS ARE IN MILLIMETRES (mm)</small>  Trafalgar Head Office: PO BOX 545 Chester Hill NSW 2162 T: 1800 888 714 F: 1800 201 500 E: info@tfire.com.au W: www.tfire.com.au
Drawing No. : 9	Sheet: 9 of 13	Date: 10/05/2024	Scale: NTS	Based on Report No.:	Checked By: CT	<input type="checkbox"/> STANDARD DRAWING <input type="checkbox"/> PROJECT DRAWING			

Concrete Slabs (with or without permanent formwork)

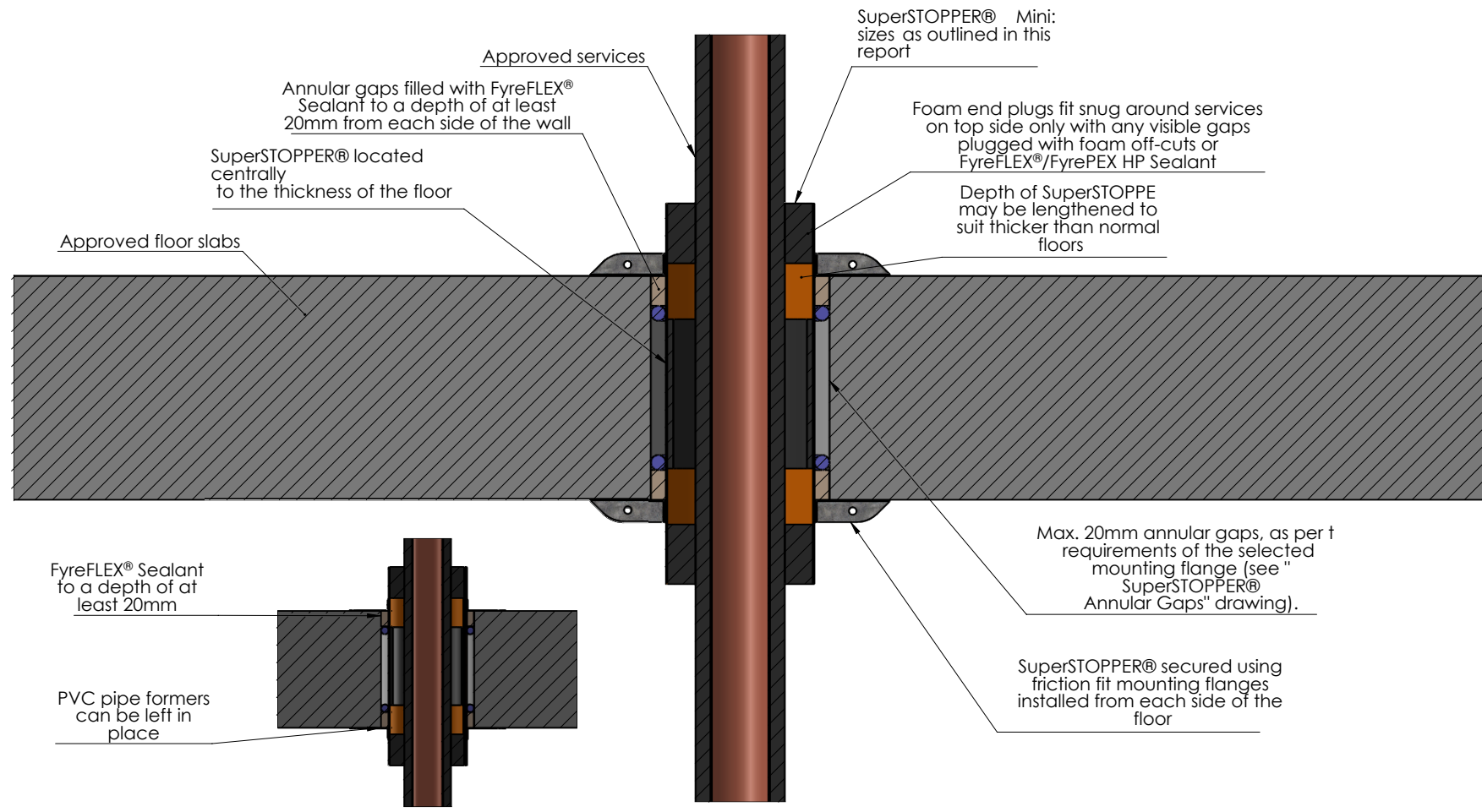

Drawing Name: Concrete Slabs				Test Standard: AS1530.4	Codes:	Revision:	Date:	No.:	NOTICE:
Project Title: SuperSTOPPER® - Generic Install				Fire resistance level:	Drawn By: JC				<small>NOTE: ALL DIMENSIONS ARE IN MILLIMETRES (mm)</small>
Drawing No. : 9	Sheet: 9 of 12	Date: 13/07/2020	Scale: NTS	Based on Report No.:	Checked By: CT	<input type="checkbox"/> STANDARD DRAWING			
						<input type="checkbox"/> PROJECT DRAWING			

Maxilite

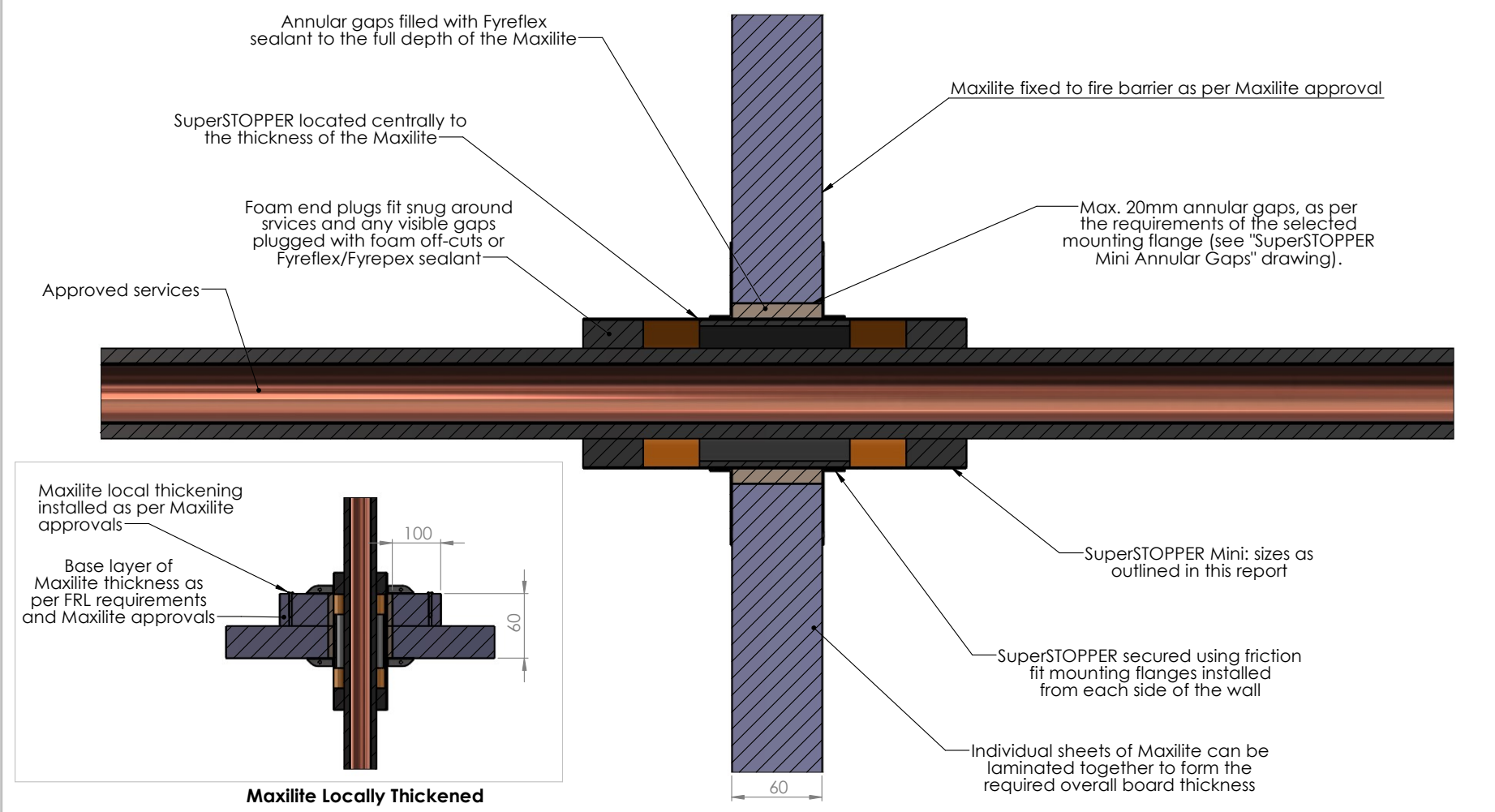

Drawing Name: Maxilite				Test Standard: AS1530.4	Codes:	Revision:	Date:	No.:	NOTICE:
Project Title: SuperSTOPPER Mini -Generic Install				Fire resistance level:	Drawn By: RH				<small>NOTE: ALL DIMENSIONS ARE IN MILLIMETRES (mm)</small>  Trafalgar Head Office: PO BOX 545 Chester Hill NSW 2162 T: 1800 888 714 F: 1800 201 500 E: info@tfire.com.au W: www.tfire.com.au
Drawing No. : 11	Sheet: 11 of 13	Date: 10/05/2024	Scale: NTS	Based on Report No.:	Checked By: JH	<input type="checkbox"/> STANDARD DRAWING <input type="checkbox"/> PROJECT DRAWING			

TWrap - Fire Rated Walls

Where the SuperSTOPPER and/or services do not achieve full insulation, TWrap can be applied in order to increase this insulation rating up to - /XXX/120.

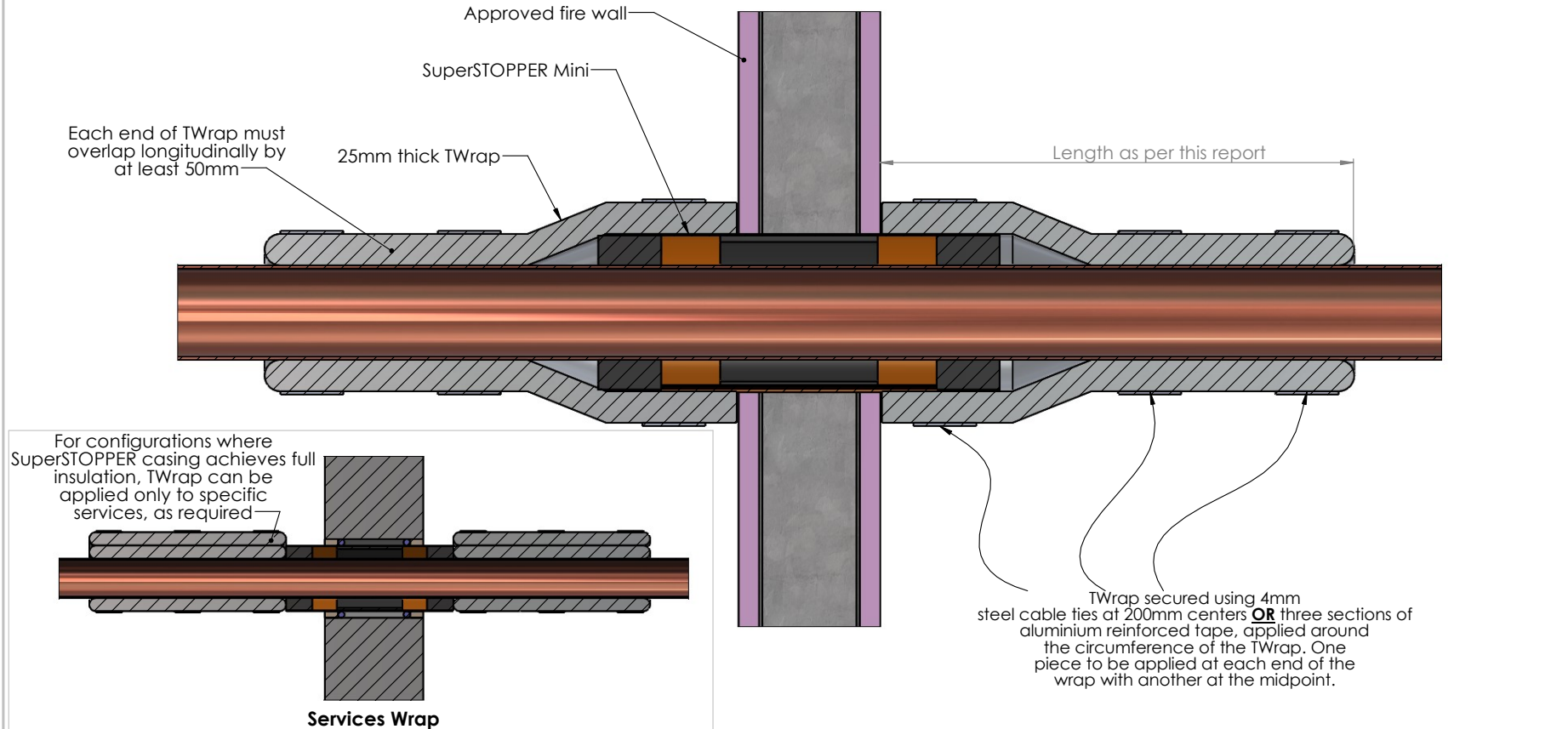

Drawing Name: TWrap - Walls				Test Standard: AS1530.4	Codes:	Revision:	Date:	No.:	NOTICE:
Project Title: SuperSTOPPER Mini -Generic Install				Fire resistance level:	Drawn By: RH				<small>NOTE: ALL DIMENSIONS ARE IN MILLIMETRES (mm)</small>  Trafalgar Head Office: PO BOX 545 Chester Hill NSW 2162 T: 1800 888 714 F: 1800 201 500 E: info@tfire.com.au W: www.tfire.com.au
Drawing No. : 12	Sheet: 12 of 13	Date: 10/05/2024	Scale: NTS	Based on Report No.:	Checked By: JH	<input type="checkbox"/> STANDARD DRAWING <input type="checkbox"/> PROJECT DRAWING			

TWrap - Fire Rated Floors

Where the SuperSTOPPER and/or services do not achieve full insulation, TWrap can be applied in order to increase this insulation rating up to -/XXX/120.

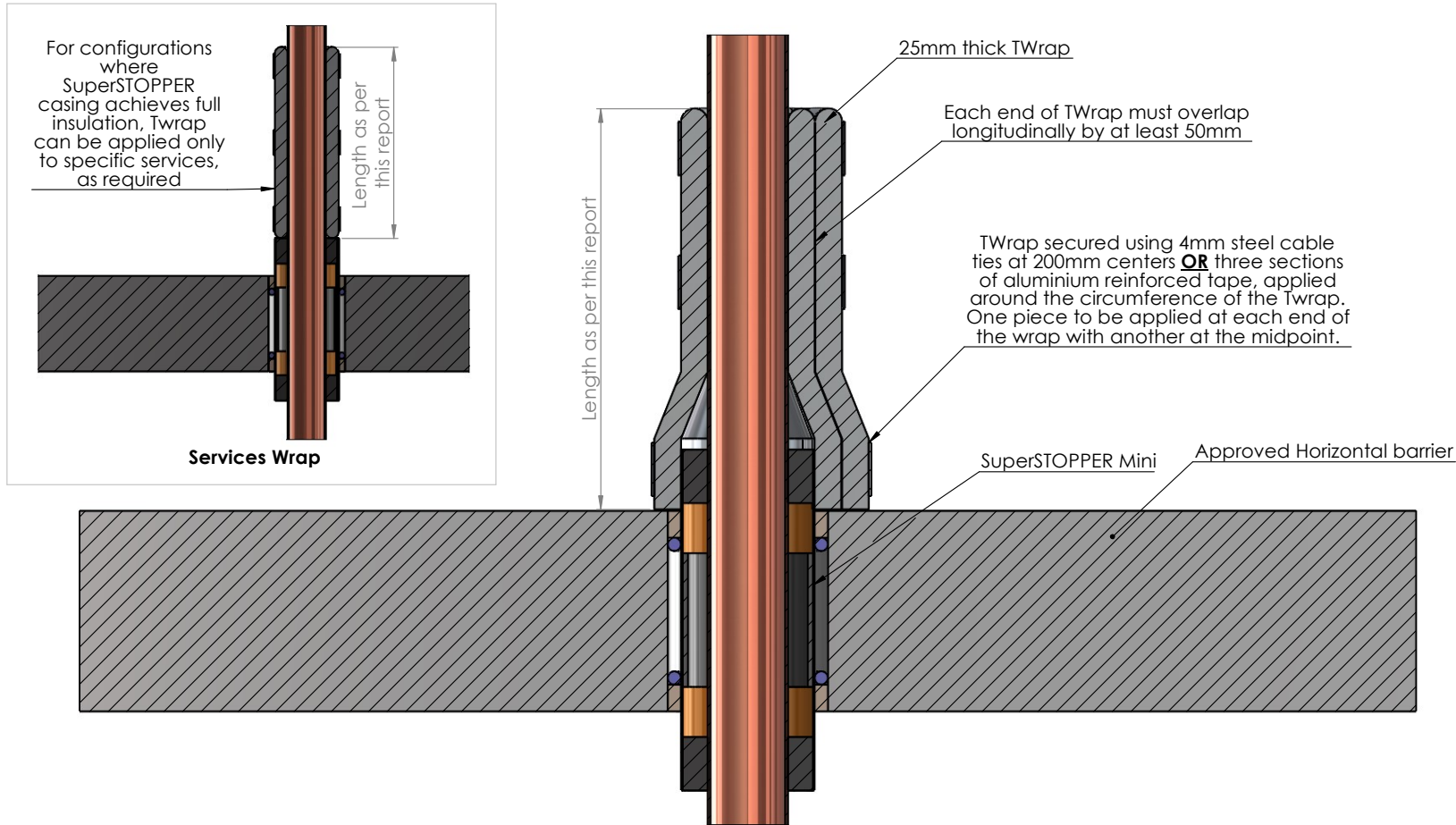

Drawing Name: TWrap - Floors				Test Standard: AS1530.4	Codes:	Revision:	Date:	No.:	NOTICE:
Project Title: SuperSTOPPER Mini -Generic Install				Fire resistance level:	Drawn By: JC				<small>NOTE: ALL DIMENSIONS ARE IN MILLIMETRES (mm)</small>  Trafalgar Head Office: PO BOX 545 Chester Hill NSW 2162 T: 1800 888 714 F: 1800 201 500 E: info@tfire.com.au W: www.tfire.com.au
Drawing No. : 13	Sheet: 13 of 13	Date: 10/05/2024	Scale: NTS	Based on Report No.:	Checked By: CT	<input type="checkbox"/> STANDARD DRAWING <input type="checkbox"/> PROJECT DRAWING			

Approved fixings

FIXING BETWEEN	FIXING SPECIFICATION (MINIMUM)	ALTERNATE
SuperSTOPPER Slab Mount and concrete slab	6mm expanding masonry bolt	4mm Hilti MX nails 6mm screw-type masonry anchors
SuperSTOPPER mounting flange and plasterboard	40mm laminating screw	8g x 50mm screws (into studwork)
SuperSTOPPER mounting flange and Hebel / Walsc AAC	8g x 50mm screws	14g hex-head fixings (as per typical Hebel specification)
SuperSTOPPER mounting flange and Speedpanel	10g x 25mm self-tapping screws	12-14 x 20mm metal screws
SuperSTOPPER mounting flange and concrete/masonry	6mm expanding masonry bolt	6mm screw-type masonry anchors
SuperSTOPPER mounting flange and Maxilite board	8g x 50mm screws	
Twrap and concrete slab (for 3-sided installation)	6mm expanding masonry bolt	4mm Hilti MX nails 6mm screw-type masonry anchors

Notes:

- All fixings used must be all-steel
- Fixings must be compatible with the barriers as outlined in this report, or as-tested

Drawing Name: Approved fixings				Test Standard: AS1530.4	Codes:	Revision:	Date:	No.:	NOTICE: <small>NOTE: ALL DIMENSIONS ARE IN MILLIMETRES (mm)</small>
Project Title: SuperSTOPPER Install Variations				Fire resistance level:	Drawn By: JC				
Drawing No. : 1	Sheet: 1 of 9	Date: 14/05/2024	Scale: NTS	Based on Report No.:	Checked By: CT	<input type="checkbox"/> STANDARD DRAWING <input type="checkbox"/> PROJECT DRAWING		 Trafalgar Head Office: PO BOX 545 Chester Hill NSW 2162 T: 1800 888 714 F: 1800 201 500 E: info@tfire.com.au W: www.tfire.com.au	

SuperSTOPPER's In Close Proximity - Floors

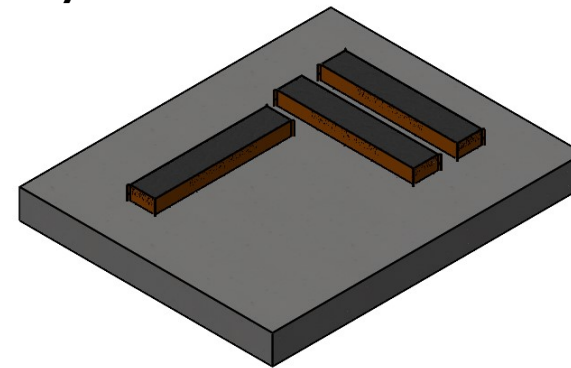
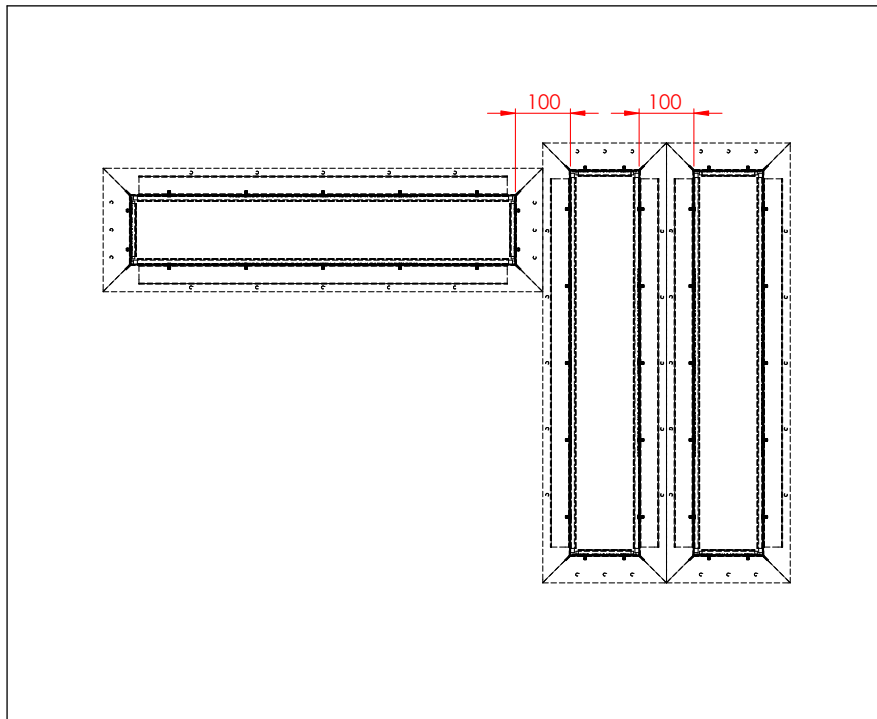

Key	SuperSTOPPER Configuration	Minimum Separation Requirement
A	Cast In to Cast In (long edges)	100mm between penetrations (Edge of bottom flanges touching)
B	Cast In to Cast In (short edges)	100mm between penetrations (Edge of bottom flanges touching)

NOTES:

Barrier must be designed or approved for the openings/spacing required
For separation distances between non-SuperSTOPPER penetrations please contact Trafalgar PRIOR to installation

Drawing Name: Penetration Separation - Floor			Test Standard: AS1530.4	Codes:	Revision:	Date:	No.:	NOTICE:
Project Title: SuperSTOPPER Install Variations			Fire resistance level:	Drawn By: JC	<small>NOTE: ALL DIMENSIONS ARE IN MILLIMETRES (mm)</small>  Trafalgar Head Office: PO BOX 545 Chester Hill NSW 2162 T: 1800 888 714 F: 1800 201 500 E: info@tfire.com.au W: www.tfire.com.au			
Drawing No. : 2	Sheet: 2 of 9	Date: 14/05/2024	Scale: NTS	Based on Report No.:				

SuperSTOPPER In Close Proximity - Walls

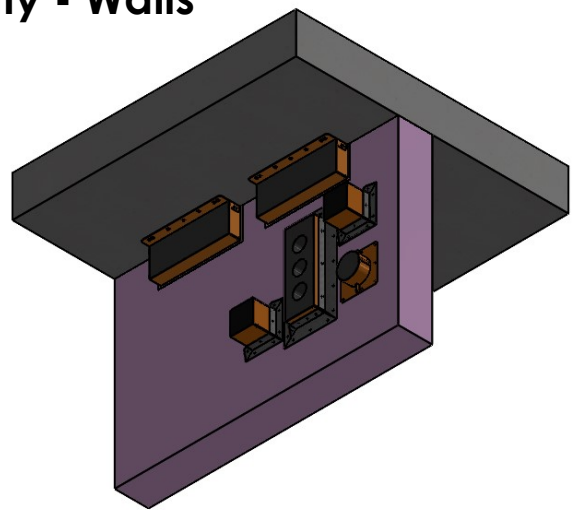
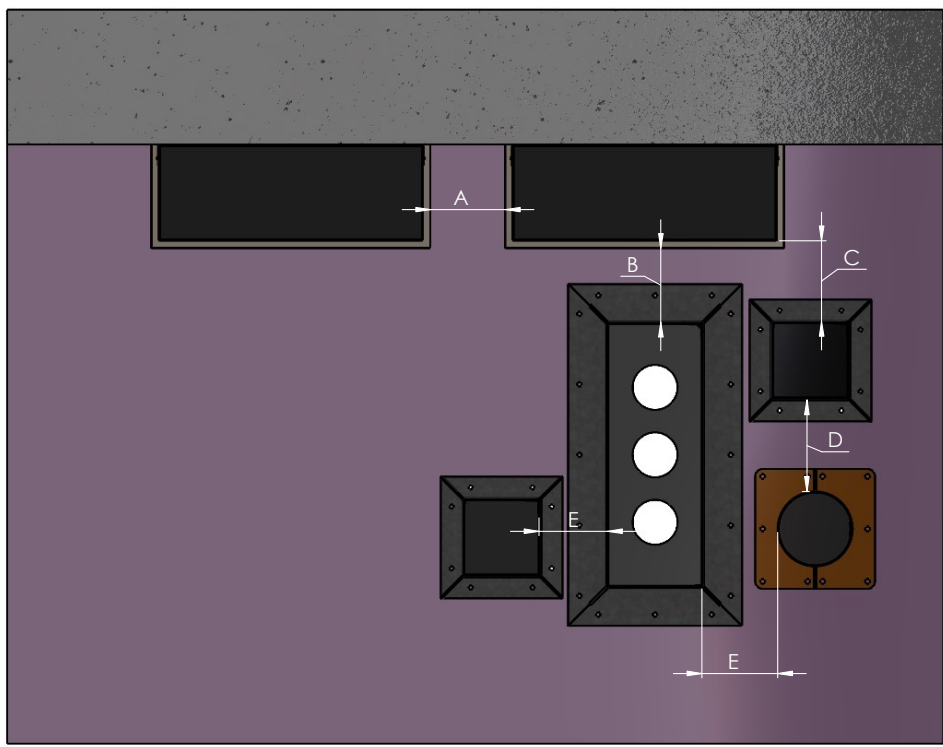

- NOTES:**
- Barrier must be designed or approved for the openings/spacing required.
 - Double-Stacking Maxi/Slab-Mount boxes allows closer penetrations.
 - For separation distances between non-Superstopper penetrations contact Trafalgar PRIOR to installation.

Key	SuperSTOPPER Configuration	Minimum Separation Requirement (between holes in wall)
A	SlabMount to SlabMount	200mm of barrier between openings
B	SlabMount to Maxi	100mm of barrier between openings
C	SlabMount to Mini	100mm of barrier between openings
D	Mini to Mini OR Maxi to Maxi	100mm of barrier between openings
E	Mini to Maxi	100mm of barrier between openings

Drawing Name: Penetration Separation - Walls				Test Standard: AS1530.4	Codes:	Revision:	Date:	No.:	NOTICE:
Project Title: SuperSTOPPER Install Variations				Fire resistance level:	Drawn By: JC	<small>NOTE: ALL DIMENSIONS ARE IN MILLIMETRES (mm)</small>  Trafalgar Head Office: PO BOX 545 Chester Hill NSW 2162 T: 1800 888 714 F: 1800 201 500 E: info@tfire.com.au W: www.tfire.com.au			
Drawing No. : 3	Sheet: 3 of 9	Date: 14/05/2024	Scale: NTS	Based on Report No.:	Checked By: CT				

SuperSTOPPER® Oversized / Scalloped Openings

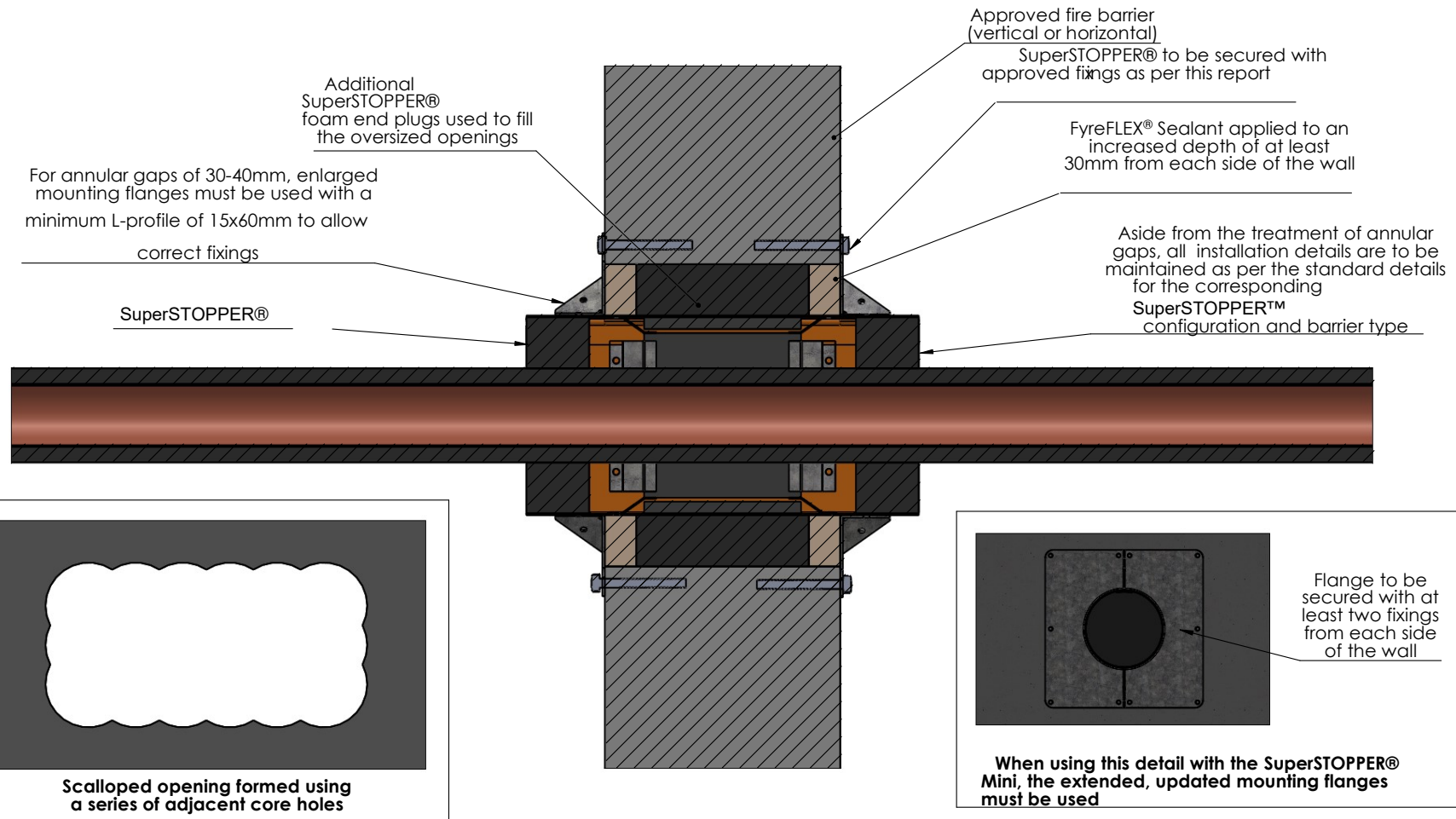

Drawing Name: Oversized / Scalloped Openings				Test Standard: AS1530.4	Codes:	Revision:	Date:	No.:	NOTICE:
Project Title: SuperSTOPPER®				Fire resistance level:	Drawn By: JC	<small>NOTE: ALL DIMENSIONS ARE IN MILLIMETRES (mm)</small>			
Drawing No. : 4	Sheet: 4 of 9	Date: 27/05/2020	Scale: NTS	Based on Report No.:	Checked By: CT				



All SuperSTOPPER Variants - Bottom Mounting Flange and Foam End Plug Removed

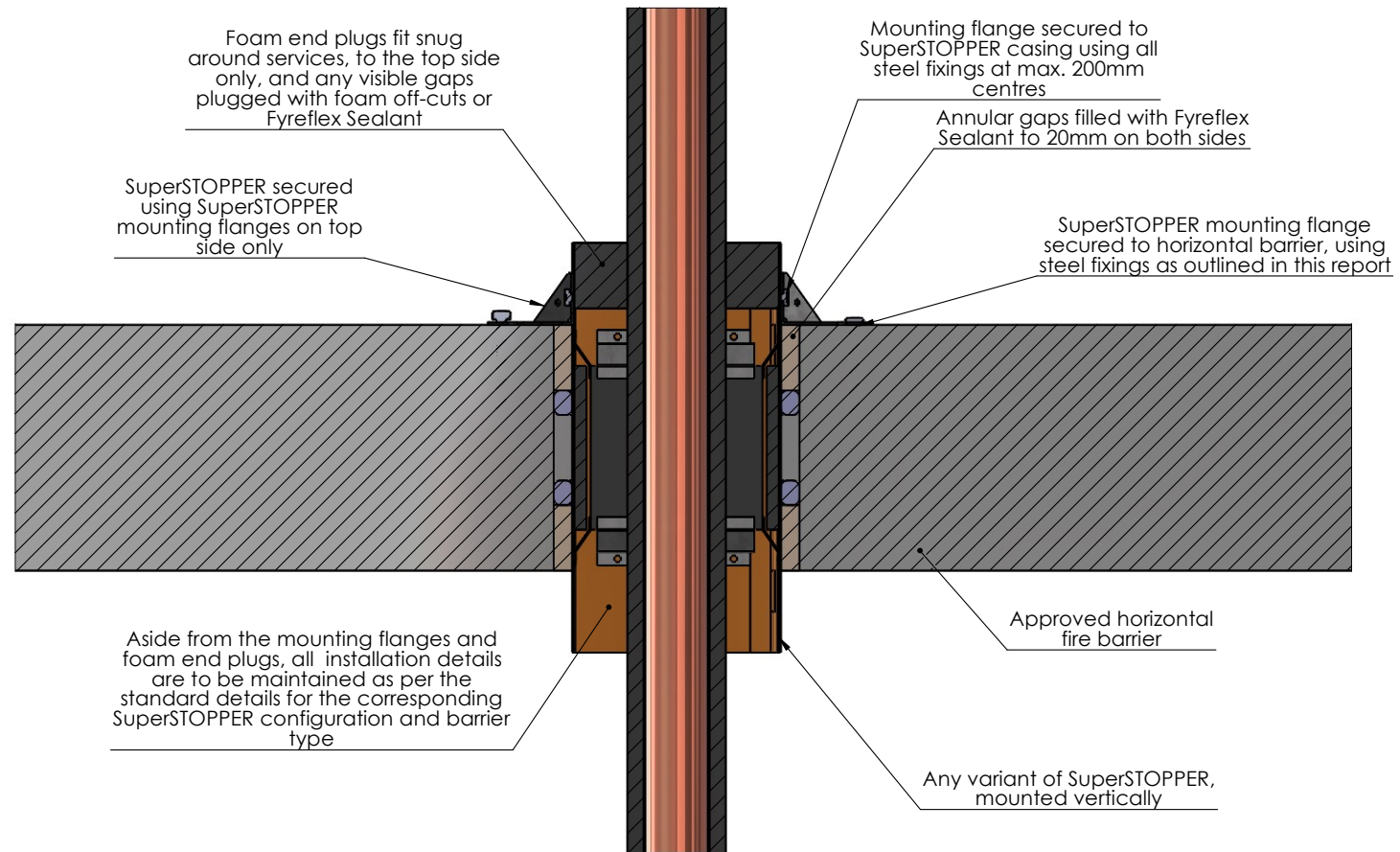

NOTE: Mounting flanges are not required for SuperSTOPPER Slab Mounted or SuperSTOPPER Cast In, as per standard installation details

Drawing Name: Bottom Foam and Flange Removed				Test Standard: AS1530.4	Codes:	Revision:	Date:	No.:	NOTICE:
Project Title: SuperSTOPPER Install Variations				Fire resistance level:	Drawn By: JC				<small>NOTE: ALL DIMENSIONS ARE IN MILLIMETRES (mm)</small>  Trafalgar Head Office: PO BOX 545 Chester Hill NSW 2162 T: 1800 888 714 F: 1800 201 500 E: info@tfire.com.au W: www.tfire.com.au
Drawing No. : 5	Sheet: 5 of 9	Date: 14/05/2024	Scale: NTS	Based on Report No.:	Checked By: CT	<input type="checkbox"/> STANDARD DRAWING <input type="checkbox"/> PROJECT DRAWING			

All SuperSTOPPER Variants - Wrapped Casing

Where the SuperSTOPPER configuration does not achieve 120 minutes insulation in a given fire barrier, TWrap can be applied to the exposed SuperSTOPPER casing and mounting flanges in order to increase this insulation rating up to -/XXX/120. This applies to the insulation rating of the SuperSTOPPER only and the insulation rating of individual services may need to be addressed seperately.

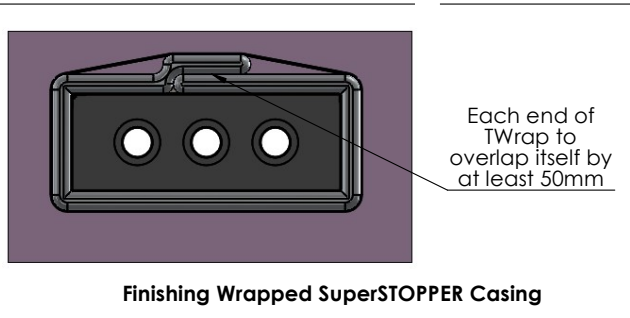
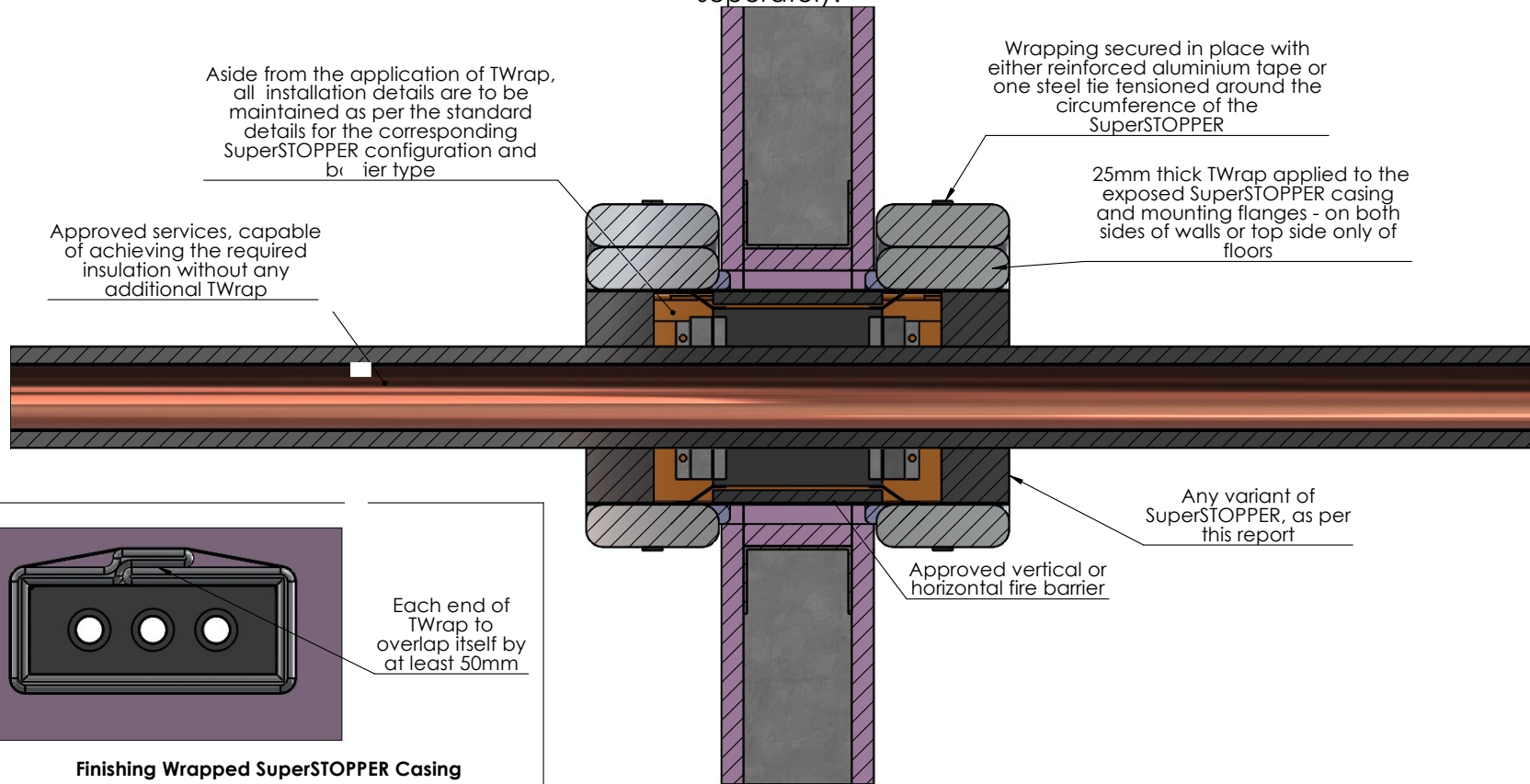



Finishing Wrapped SuperSTOPPER Casing

Drawing Name: Wrapped Casing				Test Standard: AS1530.4	Codes:	Revision:	Date:	No.:	NOTICE:
Project Title: SuperSTOPPER Install Variations				Fire resistance level:	Drawn By: JC				<small>NOTE: ALL DIMENSIONS ARE IN MILLIMETRES (mm)</small>  Trafalgar Head Office: PO BOX 545 Chester Hill NSW 2162 T: 1800 888 714 F: 1800 201 500 E: info@tfire.com.au W: www.tfire.com.au
Drawing No. : 6	Sheet: 6 of 9	Date: 14/05/2024	Scale: NTS	Based on Report No.:	Checked By: CT	<input type="checkbox"/> STANDARD DRAWING <input type="checkbox"/> PROJECT DRAWING			

All SuperSTOPPER Variants - Chilled Water Pipes

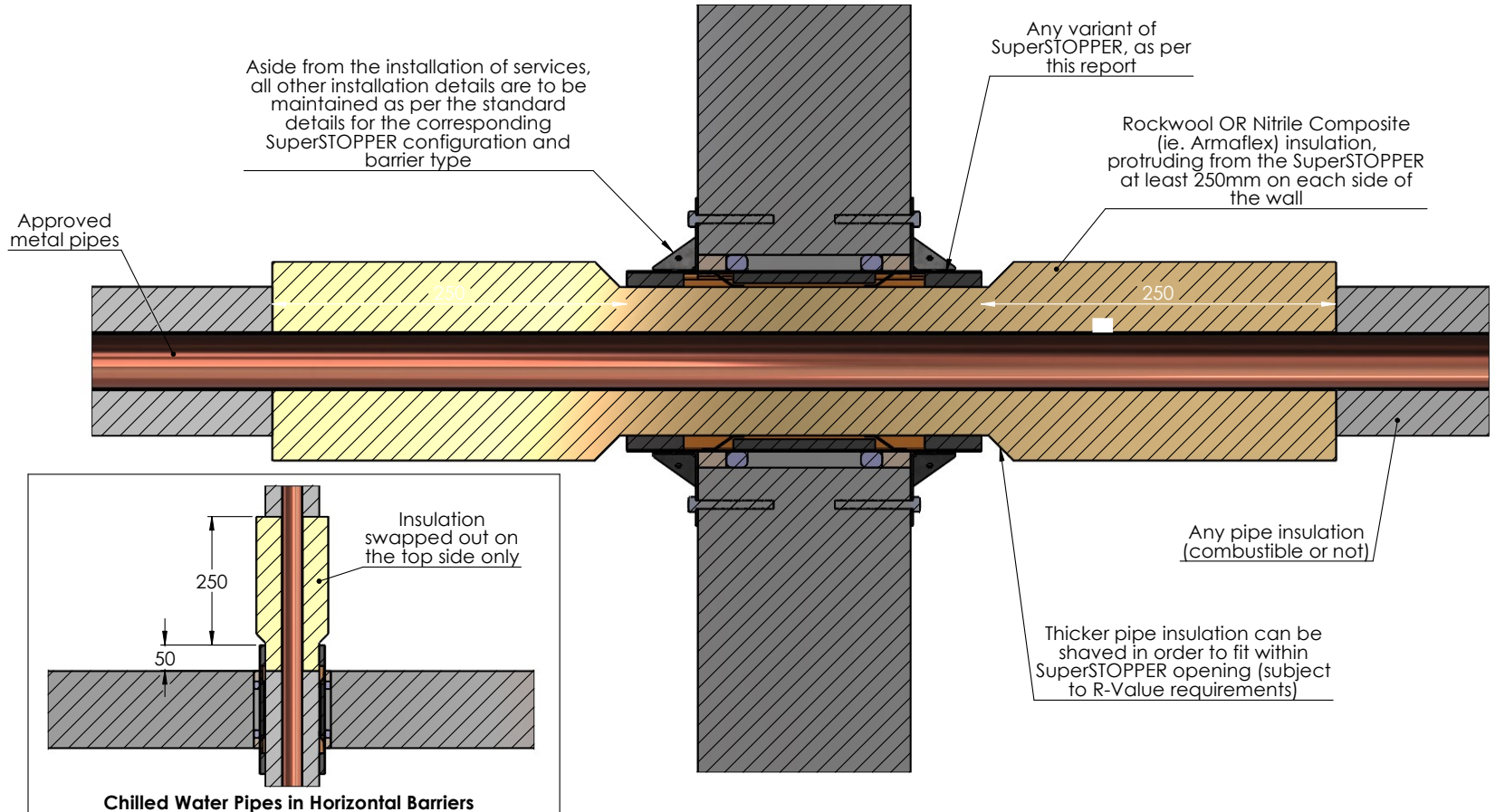
Metal pipes insulated with any material not already approved for use with the SuperSTOPPER (combustible or not), can be run through the penetration by swapping out a section for any thickness of Rockwool or Nitrile Composite (ie Armaflex) insulation



Drawing Name: Chilled Water Pipes			Test Standard: AS1530.4	Codes:	Revision:	Date:	No.:	NOTICE:
Project Title: SuperSTOPPER Install Variations			Fire resistance level:	Drawn By: JC				<small>NOTE: ALL DIMENSIONS ARE IN MILLIMETRES (mm)</small>  Trafalgar Head Office: PO BOX 545 Chester Hill NSW 2162 T: 1800 888 714 F: 1800 281 500 E: info@tfire.com.au W: www.tfire.com.au
Drawing No. : 7	Sheet: 7 of 9	Date: 14/05/2024	Scale: NTS	Based on Report No.:	Checked By: CT	<input type="checkbox"/> STANDARD DRAWING <input type="checkbox"/> PROJECT DRAWING		

SuperSTOPPER Maxi, Mini & Cast In - installed at any angle

SuperSTOPPER variant to be installed, in approved vertical or horizontal fire barrier, as per standard details relevant to the barrier type.

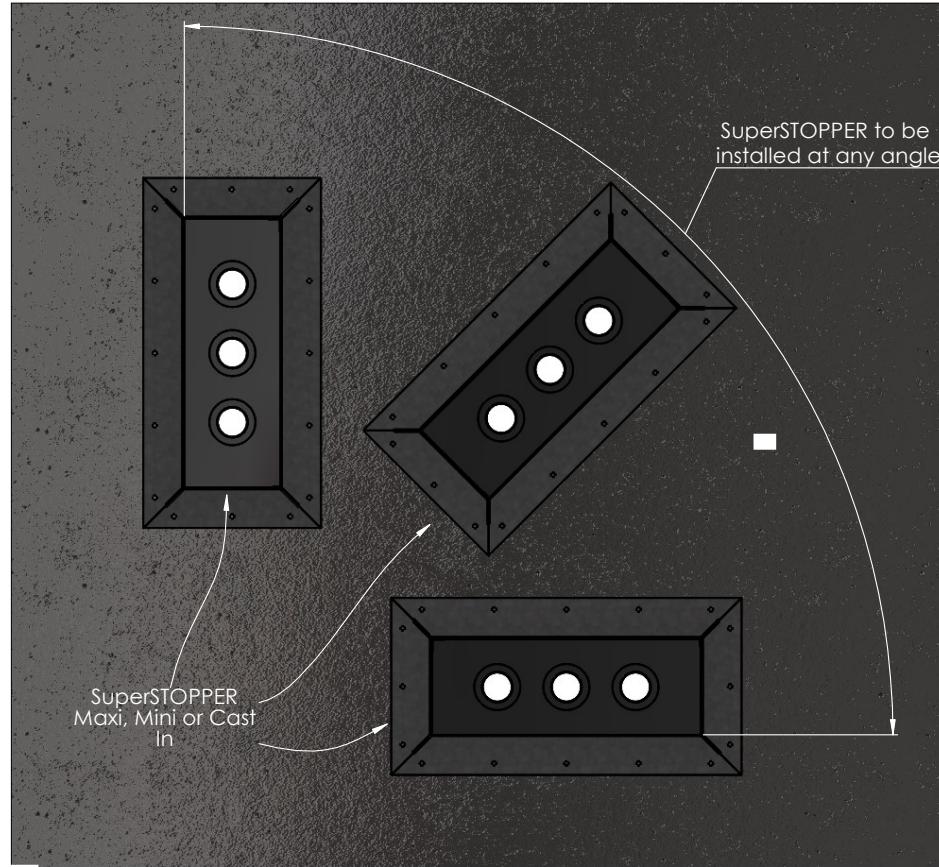

Notes:
 Barrier must permit the size and location/orientation of opening
 All other installation details as standard

Drawing Name: SuperSTOPPER At Any Angle				Test Standard: AS1530.4	Codes:	Revision:	Date:	No.:	NOTICE:
Project Title: SuperSTOPPER Install Variations				Fire resistance level:	Drawn By: JC				<small>NOTE: ALL DIMENSIONS ARE IN MILLIMETRES (mm)</small>  Trafalgar Head Office: PO BOX 545 Chester Hill NSW 2162 T: 1800 888 714 F: 1800 201 500 E: info@tfire.com.au W: www.tfire.com.au
Drawing No. : 8	Sheet: 8 of 9	Date: 14/05/2024	Scale: NTS	Based on Report No.:	Checked By: CT	<input type="checkbox"/> STANDARD DRAWING <input type="checkbox"/> PROJECT DRAWING			

All SuperSTOPPER Variants - Centre With Maxilite

Note - This installation detail takes the FRL's for Maxilite installations

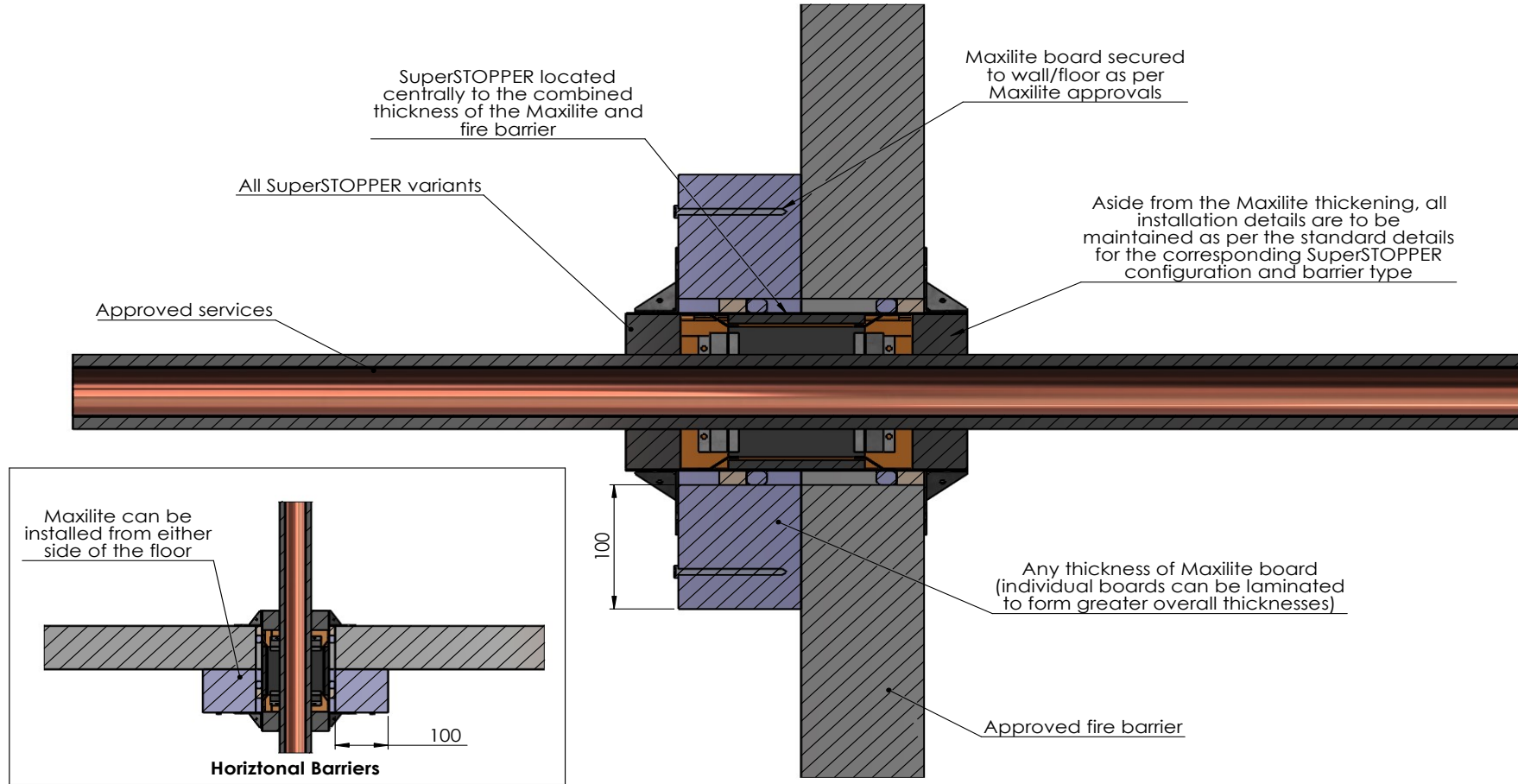

Drawing Name: Centre With Maxilite

Test Standard:
AS1530.4

Codes:

Revision:

Date:

No.:

NOTICE:

Project Title: SuperSTOPPER Install Variations

Fire resistance level:

Drawn By:
JC

NOTE: ALL DIMENSIONS ARE IN MILLIMETRES (mm)

Drawing No. :
9

Sheet:
9 of 9

Date:
14/05/2024

Scale:
NTS

Based on Report No.:

Checked By:
CT

STANDARD DRAWING
 PROJECT DRAWING



Trafalgar Head Office:
PO BOX 545
Chester Hill NSW 2162
T: 1800 888 714
F: 1800 201 500
E: info@tfire.com.au
W: www.tfire.com.au