

Technical Specifications

APPLICATION

- Used in hydrant systems to protect against fires in and around residential and commercial buildings
- Suitable for SA

CERTIFICATION

- Standards Mark Certificate – SMK21674
- Manufactured, inspected, and checked in accordance with AS2419.2.
- Storz fitting complies with NEN3374



PERFORMANCE

Working Pressure	1600kPa
Test Pressure	2700kPa
Maximum Temperature	60°C

PRODUCT DATA

Valve Inlet	80mm Roll Groove with 65mm Female BSP
Valve Outlet	Loctite Storz
Weight	4.3kg





MATERIALS

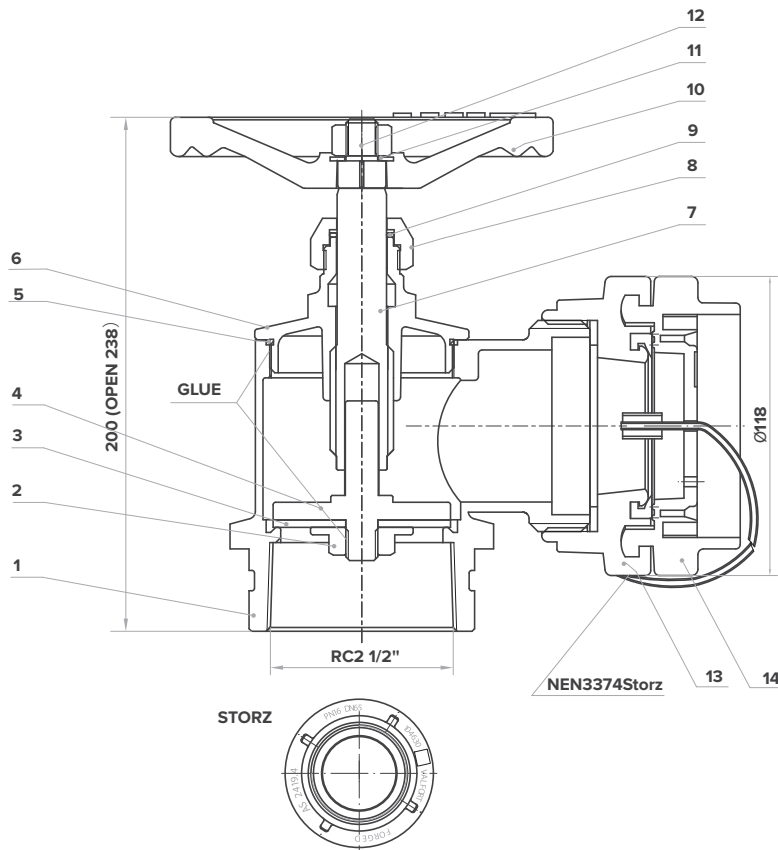

#	PART NAME	QTY	MATERIAL
1	Body	1	C83600
2	Nut	1	C48600
3	Disk Washer	1	NBR
4	Disk	1	C48600
5	Body to Bonnet Seal	1	NBR
6	Bonnet	1	C83600
7	Stem	1	C48600
8	Stem Seal	1	C48600
9	O-Ring	1	NBR
10	Handwheel	1	T200
11	Washer	1	STS316
12	Nut	1	STS316
13	2 1/2" Storz	1	
14	Cap & Chain	1	

NOTE

- Body thickness is equal to or greater than 3mm.
- The number of complete turns of the handwheel to fully open or fully close shall not exceed 10.

SPARE PARTS

The following kits are available at Reece. Individual spare parts may be ordered on request.

DESCRIPTION	PRODUCT CODE
Valfort Landing Valve Handle Spares Kit	1539764
Valfort Landing Valve Stem Spares Kit	1539768
Valfort Landing Valve Jumper Valve Kit	1539773

MAINTENANCE INSTRUCTIONS

This hydrant landing valve requires routine servicing and maintenance in accordance with AS1851.