

# ARMITAGE SHANKS

## HINGED SUPPORT RAIL 800MM

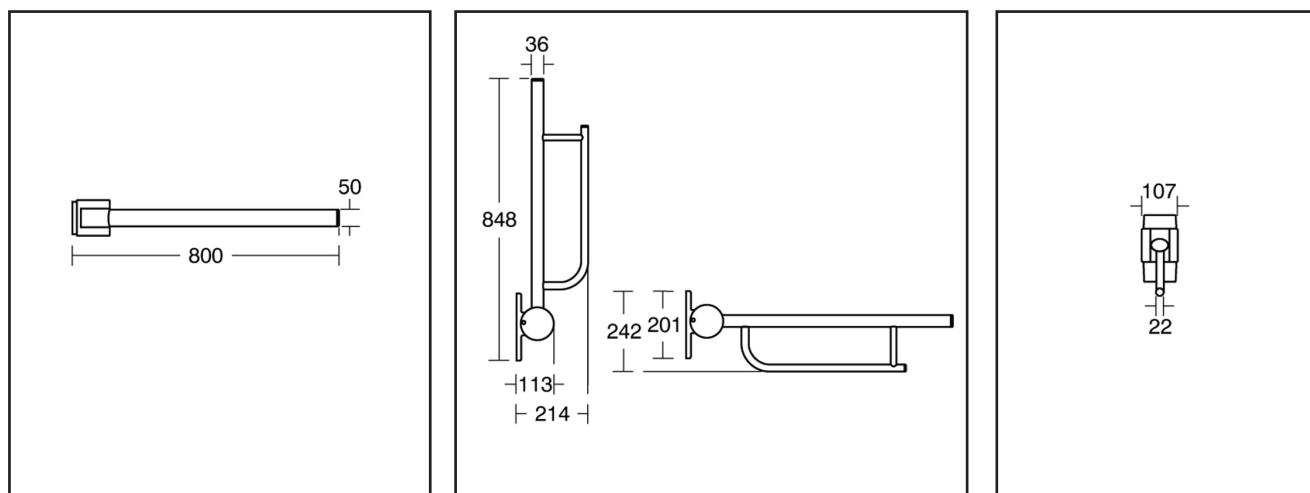

Dimensions are nominal measurements only.

### SPECIFICATIONS

<b>Recommended use</b>	Healthcare
<b>Material</b>	Aluminium/Plastic
<b>Colour</b>	White
<b>Weight</b>	Rail 3.2 kg & Toilet Roll Holder 0.1 kg
<b>Load</b>	Tested 200kg



To see the complete Armitage Shanks range go to [www.reece.com.au/bathrooms](http://www.reece.com.au/bathrooms)

### CLEANING RECOMMENDATIONS

Clean regularly with warm soapy water or mild detergent. A little disinfectant may be added. Dry with a soft cloth. Prompt and thorough cleaning immediately after use prevents build up of insoluble lime salts in hard water areas and tide mark deposits. Stubborn stains may be removed by use of a mild scouring powder.

**Disclaimer:** Products in this specification manual must by regulation be installed by licensed and registered trade people. The manufacturer/distributor reserves the right to vary specifications or delete models from their range without prior notification. Dimensions and set-outs listed are correct at time of publication however the manufacturer/distributor takes no responsibility for printing errors.

Tech Page Version 1

# ARMITAGE SHANKS

## HINGED SUPPORT RAIL 800MM

### Important Note

All measurements are subject to accepted manufacturing tolerances. To ensure accuracy please check actual product dimensions before drilling for installation. The manufacturer reserves the right to change specification at anytime without giving prior notification. This product should be installed by a qualified plumber. Local authority, Water Board and Building Regulations may apply to the installation of this product, and you should consult the appropriate bodies on these requirements.

### INSTALLATION INSTRUCTIONS

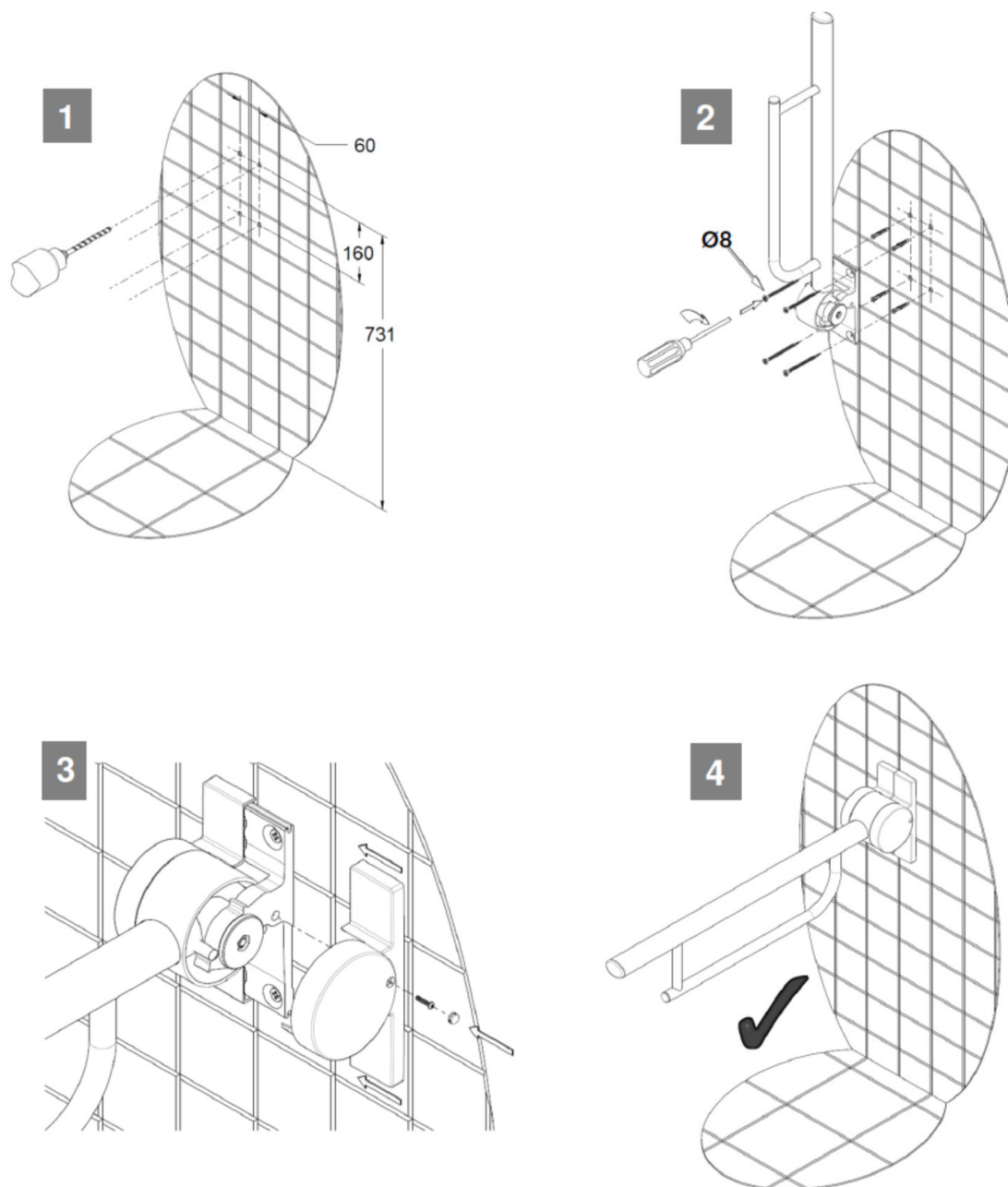

Plumbers, please ensure a copy of the installation instructions is left with the end user for future reference

# ARMITAGE SHANKS

## HINGED SUPPORT RAIL 800MM

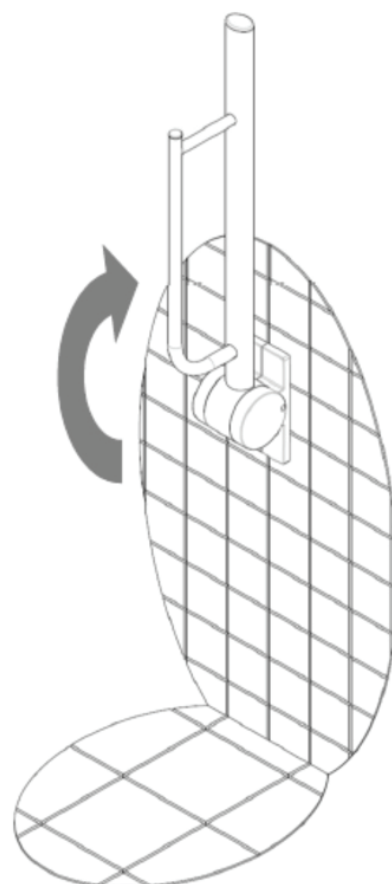
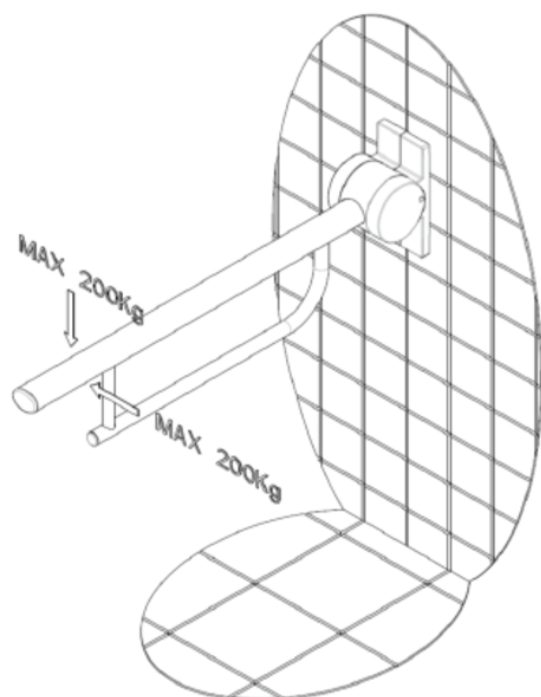
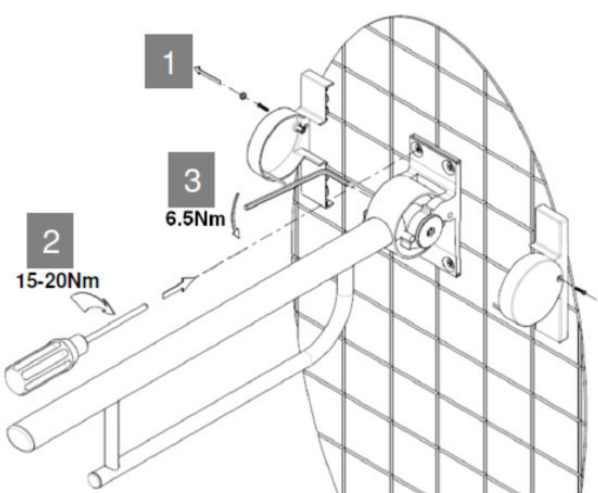

Plumbers, please ensure a copy of the installation instructions is left with the end user for future reference

# ARMITAGE SHANKS HINGED SUPPORT RAIL 800MM

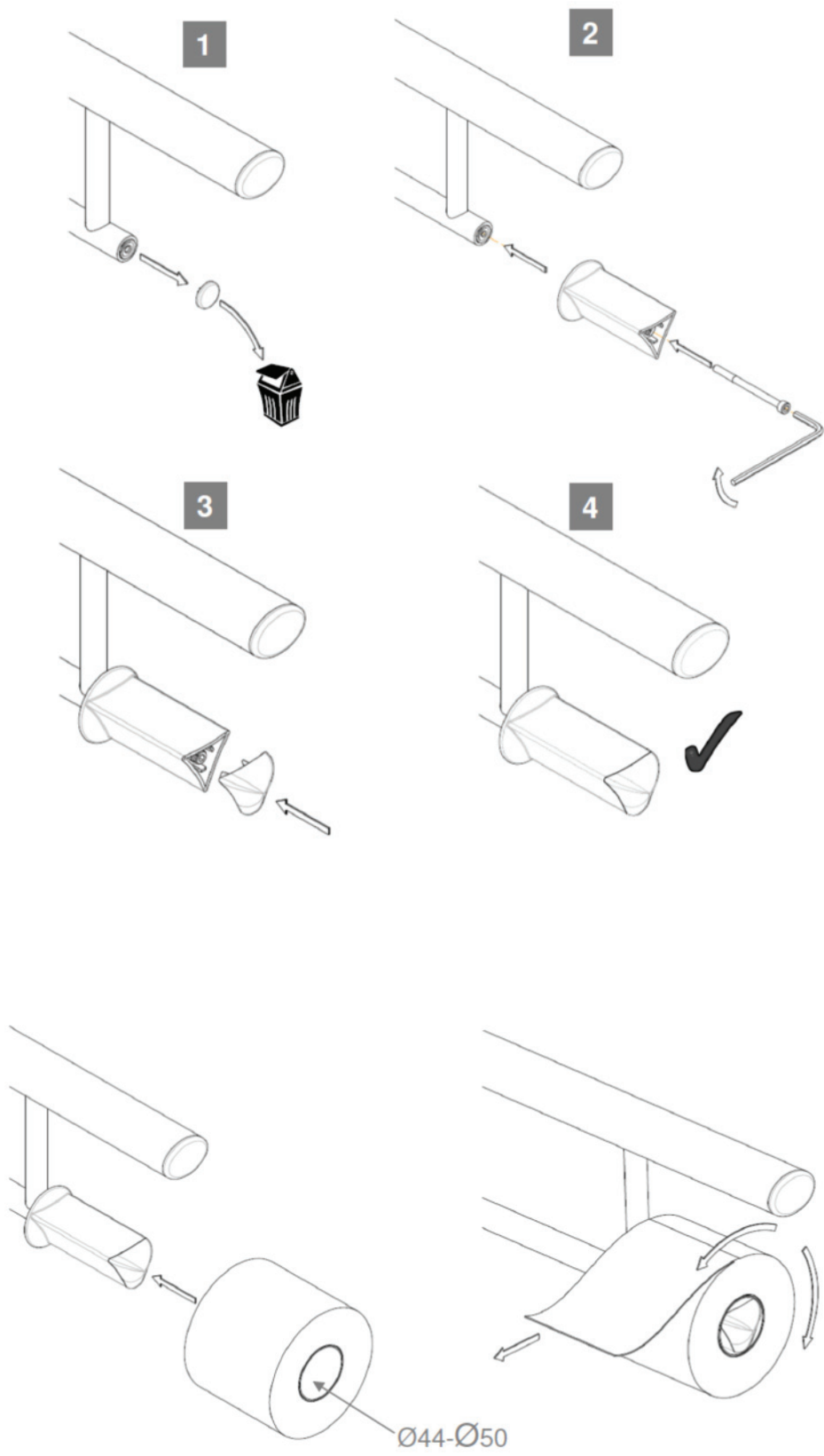

Plumbers, please ensure a copy of the installation instructions is left with the end user for future reference



## REECE PRODUCT QUALITY GUARANTEE

You have purchased a quality product from Reece Pty Ltd ABN 84 004 097 090 ("Reece"). This product is covered by a 5 year replacement product warranty and a 12 month warranty over spare parts and labour.

### 5 YEAR WARRANTY

This warranty covers faults in the product construction, material and assembly. Products which are within 5 years from the date of purchase, found upon inspection by an authorised Reece representative, to be defective in construction, material or assembly, will be repaired or exchanged with an equivalent product free of charge. Replaced items become Reece's property.

All replacement products will be available for collection without charge to the customer at the nearest Reece branch to the customer's location, or elsewhere as agreed between the customer and Reece.

### Labour and Spare Parts

The labour for the replacement of products and spare parts to which this warranty applies will be supplied by Reece or relevant supplier using licensed plumbers engaged by Reece or relevant supplier within 1 year from the date of purchase.

Spare parts which are within 1 year from the date of purchase found upon inspection by an authorised Reece representative to be defective in construction, material or assembly, will be replaced free of charge.

### Warranty Conditions

This warranty will apply only under all of the following conditions:

- The item has been installed by a licensed plumber
- Failure is due to a fault in the manufacture of the product
- Proof of purchase (including the date of purchase) is provided
- The installation of the product is in accordance with the instructions provided

This warranty does not cover products purchased as an ex-display without being fully checked and tested for sale by the manufacturer.

This warranty does not include faults caused by:

- Unsuitable or improper use
- Incorrect installation or installation not in accordance with the instructions provided
- Installation or part installation by the purchaser or any person other than a LICENSED PLUMBER
- Normal wear and tear
- Inadequate or complete lack of maintenance
- Chemical, electrochemical or electrical influences
- Harsh detergents or abrasive cleaners used on product finishes

### EXCLUSIONS

To the fullest extent permitted by law, Reece excludes all liability for damage or injury to any person, damage to any property, and any indirect consequential or other loss or damage.

### CLAIM PROCEDURE

For all warranty queries customers are to contact the branch where the product was purchased. These details can be found on your purchase invoice.

Our goods come with guarantees that cannot be excluded under the Australian Consumer Law. You are entitled to a replacement or refund for a major failure and for compensation for any other reasonably foreseeable loss or damage. You are also entitled to have the goods repaired or replaced if the goods fail to be of acceptable quality and the failure does not amount to a major failure.