

# UNILIFT AP 35 & 50

**2**  
YEAR  
WARRANTY

HEAVY DUTY, SUBMERSIBLE STAINLESS STEEL GREY WATER PUMP

## WATER SOURCE



Storm/  
Grey Water

## APPLICATION



Storm/Grey  
Water Handling

- **Highly corrosion resistant stainless steel construction inside and out**
- Ideal for draining **dirty storm water** or **grey water** with larger fibrous particles
- **Suitable for fully or partially submerged use**
- **Available with or without float switch**
- Suitable for **permanent installation** or as a **portable pump**



## MAXIMUM PARTICLE SIZE

It's a good idea to check your water source to make sure it doesn't contain dirt, fibres, plant or other material that is larger than **35 mm (AP 35)**. If you require a drainage pump capable of larger particle sizes, up to **50 mm** the **AP 50** is recommended.

If you need to handle particles larger than **50 mm**, please speak to your authorised Grundfos dealer.



AP 50 & AP 50B  
**50 mm**

## CONTROL & PROTECTION FEATURES



### FLOAT SWITCH

External float that either turns your pump on or off based on the water level - this prevents overflowing and dry-running.

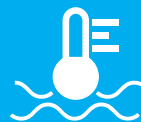

### SELF-COOLING MOTOR

The pump is cooled by water being pumped, protecting it from overheating, even when only partially submerged.

be  
think  
innovate

**GRUNDFOS**

## FIND SPACE FOR YOUR PUMP

If you are planning to install the UNILIFT AP 35 & 50 in a drainage pit and will rely on the float switch to automatically start and stop your pump, a minimum amount of space in the pit is required for free movement of the float.

See below pit dimensions:

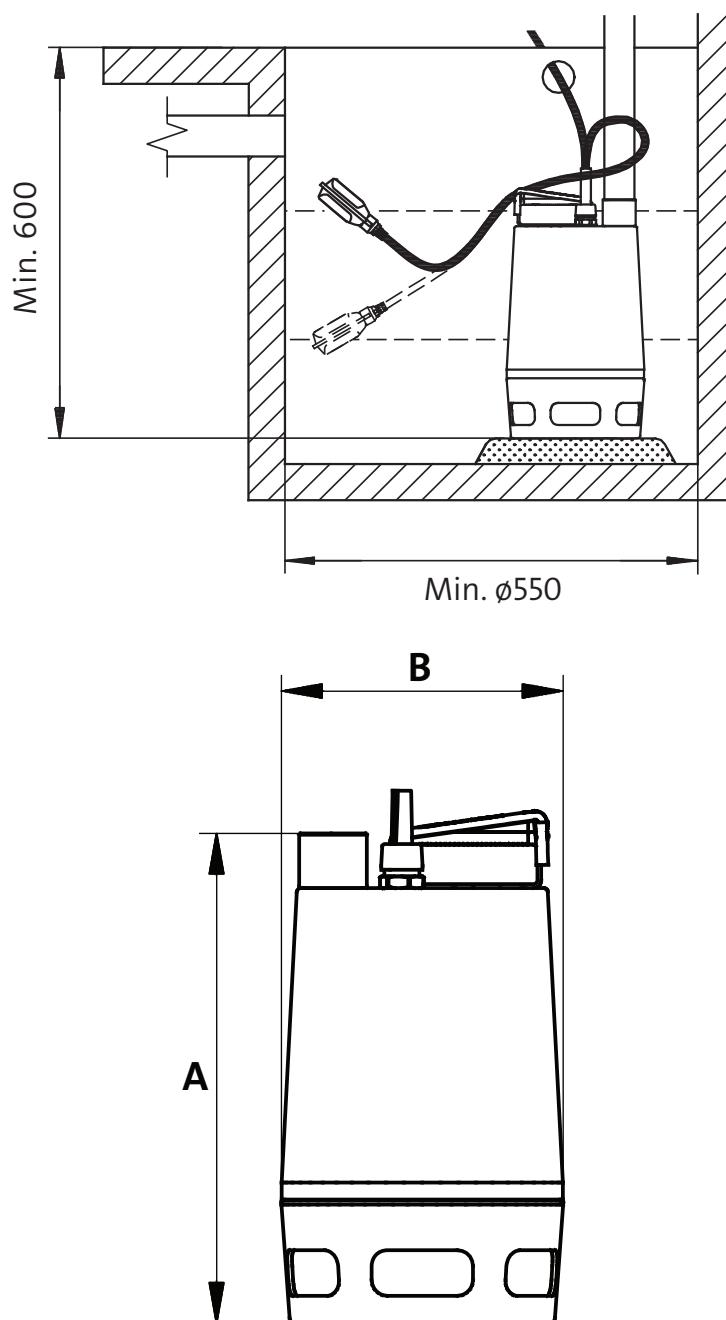

Model	Connection Outlet	Dimensions (mm)	
		A (h)	B (w)
UNILIFT AP 35.40.06	1½" Female	376	216
UNILIFT AP 35.40.08		410	216
UNILIFT AP 50.50.08	2" Female	436	241
UNILIFT AP 50.50.11		436	241