

**NOTE:** REGAL AUSTRALIA IS HAPPY TO PROVIDE TECHNICAL ASSISTANCE TO OUR CUSTOMERS IN MANY AREAS. HOWEVER, SINCE REGAL AUSTRALIA IS NOT AWARE OF ALL DATA CONCERNING THE USE AND APPLICATION OF THIS MOTOR, THE SUITABILITY OF THE MOTOR FOR THE APPLICATION MUST BE DETERMINED BY AND IS THE RESPONSIBILITY OF THE CUSTOMER.



### MOTOR SPECIFICATION

CUSTOMER				
CUSTOMER P/N				
QR No.		CAPACITOR	uf / V	
POWER OUTPUT	25W	START	NIL	
MOTOR TYPE		RUN	NIL	
SUPPLY	VOLTS	HERTZ	PHASE	POLES
	240	50	SINGLE	4
ENCLOSURE	TOTALLY ENCLOSED			
SPEED (RPM) AT RATED OUTPUT	1300	WINDING TYPE		
ROTATION	ANTI-CLOCKWISE (DRIVE END)			
INSULATION CLASS	F	DUTY	S1	
THERMAL PROTECTION	AUTO RESET			
RATED CURRENT	0.7	AMPS AT RATED OUTPUT		
APPLICATION	FAN DRIVE			
MOUNTING	TAPPED HOLES IN ENDSHIELD OR STUDS			
BEARING & LUBRICATION	IRON SLEEVE BEARINGS			
SUPPLY LEAD	COLOUR	BLACK		
	<input checked="" type="checkbox"/> MULTI STRAND	LENGTH	1500 ±40	
	<input type="checkbox"/> SINGLE CORE	TERMINALS		
		Q.C. HOUSING		
EARTH PROVISION				
BASIC BUILD SPECIFICATION				
PERFORMANCE SPECIFICATION				
SHAFT MATERIAL	1045 STEEL			
CONNECTION DIAGRAM		PAINT SPEC		

**SPECIAL REQUIREMENTS**

- 1) ATTACH PLASTIC BAG TO LEAD CONTAINING THE FOLLOWING :  
 4-OFF M4x8mm PAN HEAD PHILLIPS DRIVE ZP PLATED SCREWS  
 4-OFF DIA.4mm EXTERNAL SHAKEPROOF ZP PLATED WASHERS

DO NOT SCALE PRINT

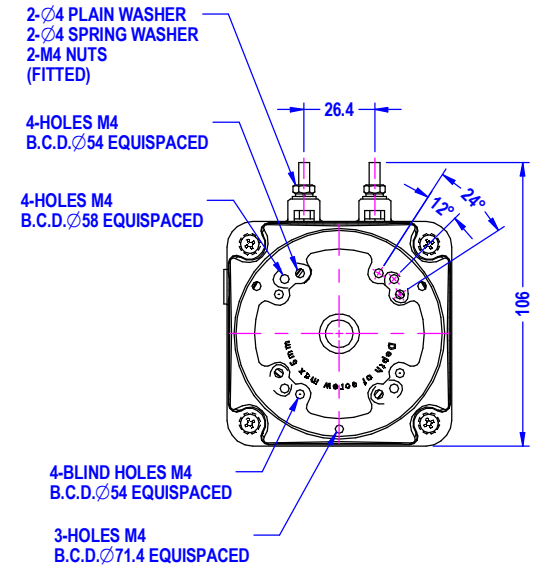
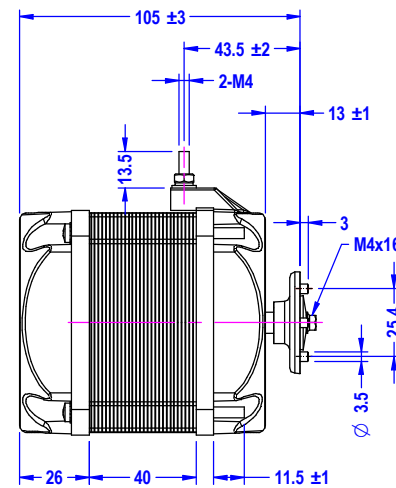
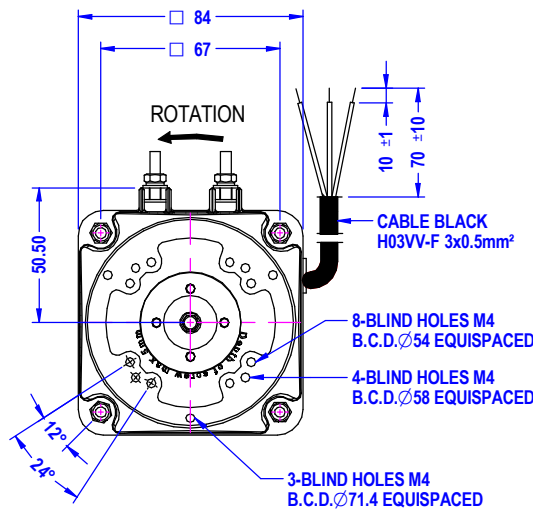

**LABEL:**

**FASCO Model:55D525-80AT**  
**240V 50Hz 0.7A 25W Duty AOM**  
**CLASS F 1300rpm ThProt 07.21.17**

**CONNECTION DIAGRAM**

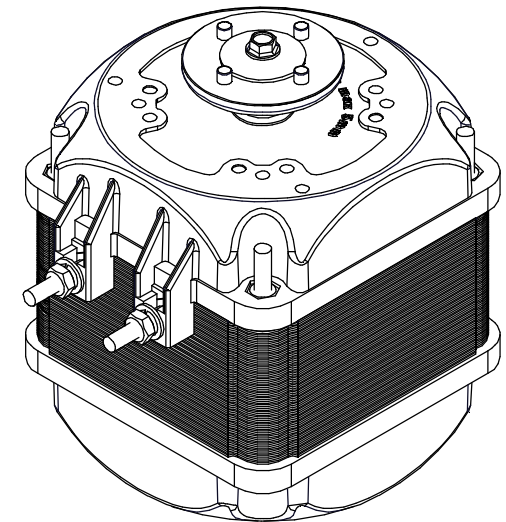
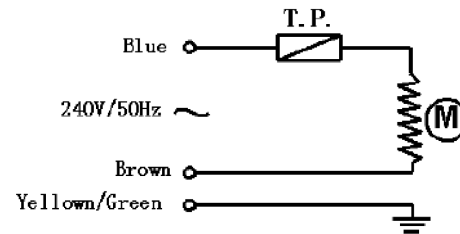

DIMENSIONS IN mm UNLESS OTHERWISE SPECIFIED	
GENERAL TOLERANCES	
LINEAR:	X = ±1.0
	XX = ±0.25
	XXX = ±0.1
ANGULAR:	X = 2°
	XX = ±0.5°
SURFACE FINISHES IN MICRO METRES. MAX 3.0	
SYMBOLS - A.S. 1100	

This drawing remains the property of Regal Australia Pty. Ltd. No part or parts of this drawing may be reproduced without written permission.

MAT'L		
FINISH		
DRAWN	Veeranut	02/10/2018
CHECKED	Roshan	02/10/2018
RELEASED		
SCALE	NTS	

**REGAL**  
 19 Corporate Avenue  
 Rowville, Melbourne  
 Victoria 3178, Australia

FRAME	MOTOR		REVISION
STATUS	4P 25W		
SHEET	DWG. NO.	55D525-80AT	A
A3			

MIC No. \_\_\_\_\_  
 By: Veeranut  
 Date: 02/10/2018  
 MIC A: NEW MODEL RELEASED  
 Note: \_\_\_\_\_