



**ASPEN  
PUMPS**  
ASIA PACIFIC

# PRODUCT CATALOGUE







**ASPEN  
PUMPS**  
ASIA PACIFIC

# PRODUCT CATALOGUE

VOLUME 2.0

The most complete range of ancillary essentials  
designed specifically for the HVAC/R industry



# ASPEN PUMPS ASIA PACIFIC

Aspen Pumps Asia Pacific Pty Ltd (formerly Pro Pipe Supplies Pty Ltd) was established in November 1999 to supply a gap in the market servicing HVAC/R wholesalers with a dedicated range of condensate drain pipe, fittings and traps specific for industry use. The company's early years were spent changing industry habits of installers using electrical conduit for Refrigeration and Air Conditioning drains.

In January 2006 Pro Pipe Supplies was appointed Master distributor in Australia for Aspen Pumps. After years of continuous growth, a strong relationship developed between the two companies which led to Aspen Pumps acquiring Pro Pipe Supplies in 2015 to strengthen their distribution and better service the Asia Pacific region.

Our global supply network and regular attendance at International Trade Shows allows us to introduce innovative products and accessories to make air conditioning installations quicker and easier for HVAC/R contractors and installers.

Our staff have gained enormous knowledge in product management, marketing and logistics which has allowed us to introduce many trusted brands to the Australian and New Zealand markets.

Aspen Pumps Asia Pacific is proud of its hard-earned reputation for supplying HVAC/R wholesalers with quality products and unsurpassed service. Our experienced team aim to supply orders in full and on time from our Lonsdale (SA) distribution centre. We also strive to provide 'Best Practice' technical back up, product training, marketing support and local representation.

Our mission is to be recognised as one of the leading suppliers to HVAC/R wholesalers of innovative, cost effective, quality products assisting the industry in the best possible installation and maintenance of air conditioning systems.



<b>Aspen Condensate Pumps</b>	Mini Pumps.....	<b>5</b>
	Tank Pumps.....	<b>13</b>
	Peristaltic Pumps.....	<b>20</b>
	Supermarket Pumps.....	<b>24</b>
<b>Air Conditioning Mounts</b>	Brackets.....	<b>31</b>
	Ground Mounts.....	<b>35</b>
	Anti Vibration.....	<b>38</b>
	Condenser Guards.....	<b>42</b>
	Big Foot Systems.....	<b>44</b>
<b>Duct &amp; Fittings</b>	Pacific Duct.....	<b>49</b>
	Pacific Fittings.....	<b>50</b>
<b>Drain Pipe &amp; Fittings</b>	Drain Pipe & Fittings.....	<b>55</b>
	Condensate Traps.....	<b>60</b>
	Flexible Drain Pipe.....	<b>62</b>
	Clear Vinyl PVC Tubing.....	<b>63</b>
	Xtra Accessories.....	<b>64</b>
<b>Pipe Supports, Channel &amp; Accessories</b>	Pipe Supports.....	<b>69</b>
	Channel & Xtra Accessories.....	<b>81</b>
<b>HVACR Tools</b>	Aspen Edge.....	<b>87</b>
	Black Diamond.....	<b>89</b>
	JB Industries.....	<b>93</b>
	Spectroline Leak Detection.....	<b>103</b>
	Brazing Torches.....	<b>107</b>
	Portable Lifter.....	<b>109</b>
<b>HVACR Chemicals</b>	Advanced Chemicals.....	<b>111</b>
	Nu-Calgon Chemicals.....	<b>116</b>
	Indoor Air Quality.....	<b>123</b>
<b>Installation &amp; Service Accessories</b>	Service Accessories.....	<b>134</b>
	Evap Super Pump.....	<b>134</b>
	Duct Tape.....	<b>135</b>



# ASPEN CONDENSATE PUMPS

<b>5</b>	Mini Pumps
<b>13</b>	Tank Pumps
<b>20</b>	Peristaltic Pumps
<b>24</b>	Supermarket Pumps

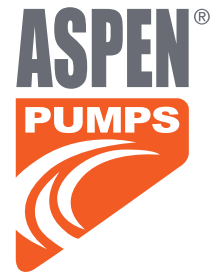

# Aspen Pumps

Since the launch of the Mini Orange, Aspen has become the global market innovator for condensate pumps.

Aspen has built a reputation for designing reliable and quiet pumps, that the installer can fit where space is limited.

Quiet

Small

Reliable

Flexible install options

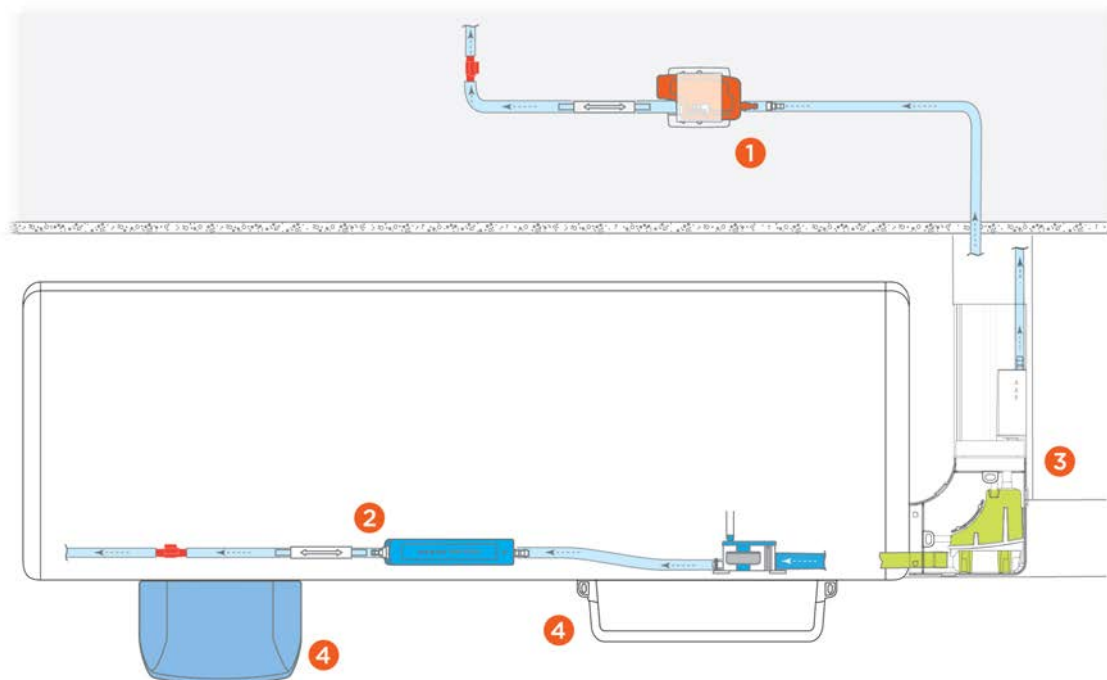

1. In the ceiling - **Orange**

2. In behind AC unit - **Aqua**

3. Next to the AC unit (within trunking) - **Lime**

4. Under the AC unit - **Blanc/White**

**Note.** Anti Siphoning Device (ASD) to be installed on discharge side of pump



## Mini Orange and Silent+ Orange

### Condensate Removal Pump

The world's best selling mini pump offers unrivaled reliability and performance.

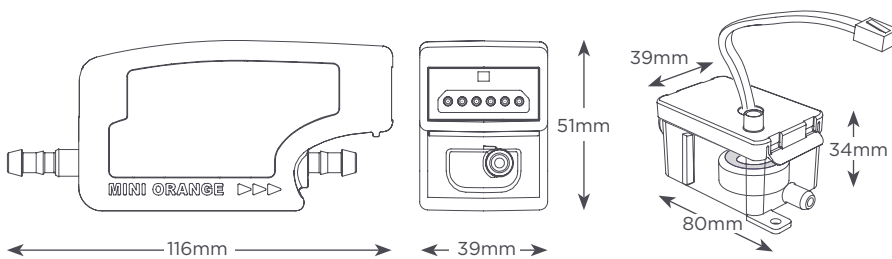

\*\*Anti-Siphon device to be installed on the discharge side of pump\*\*

### Key features

- Quiet and Reliable
- Submersible secondary reservoir included
- Plug & play
- Anti-Siphon Device

### Application

- High wall split systems
- Install in ceiling space

### Silent+ Extras to reduce noise and vibration

Acoustic Damper  
Silicon Tubing  
Rubber Bracket

#### MINI ORANGE AND SILENT+ ORANGE

Max. flow	12L/h @ 0 head
Max. rec. head	10m
Max. suction lift	1.5m
dB(A) @ 1m	19dB(A) - Silent+ Orange 21dB(A) - Mini Orange
Power supply	230 VAC, 0.11A, 16W 50/60Hz
Rated	Non continuous
Max. water temp	40°C / 104°F
Discharge tube	6mm ID
IP Protection	IP21
Safety switch	3.0A Normally closed
Thermal protection	✓
Fully potted	✓
Self priming	✓

#### MINI ORANGE OPTIONS

Silent+ Mini Orange	FP3313
Standard Mini Orange	FP2212

#### SUGGESTED XTRA ACCESSORIES

DESCRIPTION	PART NO.
Vinyl Tube Braided (6mm)	AX5100





## Mini Aqua and Silent+ Aqua

### Condensate Removal Pump

The worlds slimmest mini pump is designed to fit where others can't.

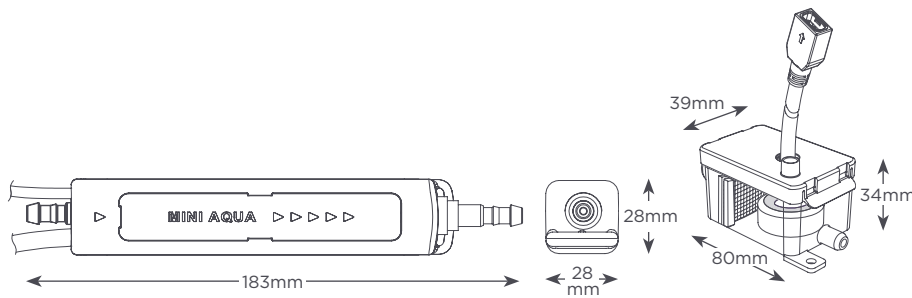

\*\*Anti-Siphon device to be installed on the discharge side of pump\*\*

### Key features

- Quietest and Reliable
- Plug & play
- Anti-Siphon Device

### Application

- High wall mini split systems
- Install behind AC unit

### Silent+ Extras to reduce noise and vibration

Acoustic Damper  
Silicon Tubing  
Rubber Bracket

#### MINI AQUA AND SILENT+ AQUA

Max. flow	12L/h @ 0 head
Max. rec. head	10m
Max. suction lift	1.5m
dB(A) @ 1m	19dB(A) - Silent+ Aqua 21dB(A) - Mini Aqua
Power supply	230 VAC, 0.1A, 16W 50/60Hz
Rated	Non continuous
Max. water temp	40°C / 104°F
Discharge tube	6mm ID
IP Protection	IP24
Safety switch	3.0A Normally closed
Thermal protection	✓
Fully potted	✓
Self priming	✓

#### SILENT+ MINI AQUA OPTIONS

Silent+ Mini Aqua	FP3326
Standard Mini Aqua	FP2406

#### SUGGESTED XTRA ACCESSORIES

DESCRIPTION	PART NO.
Vinyl Tube Braided (6mm)	AX5100



## ASPEN CONDENSATE PUMPS

# Silent+ Mini Lime FP3312

### Condensate Removal Pump

The next generation Silent+ Mini Lime has an anti-vibration damper and built-in sound absorbing materials. As well as a quick release reservoir, you can also commission the pump on site, and check operation via the LED system in the reservoir. Silence isn't golden, it's lime.

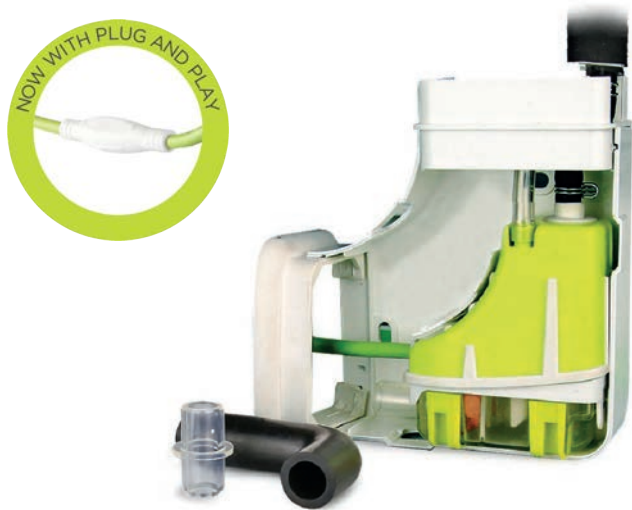

### Key features

- Anti-vibration damper
- Pump sits in trunking elbow
- LEDs provide visual operating feedback

### Application

- Up to 16kW / 54,000Btu/h
- High wall split systems
- Left or right install with range of trunking systems
- **Perfect for...** Commercial use where silence is important

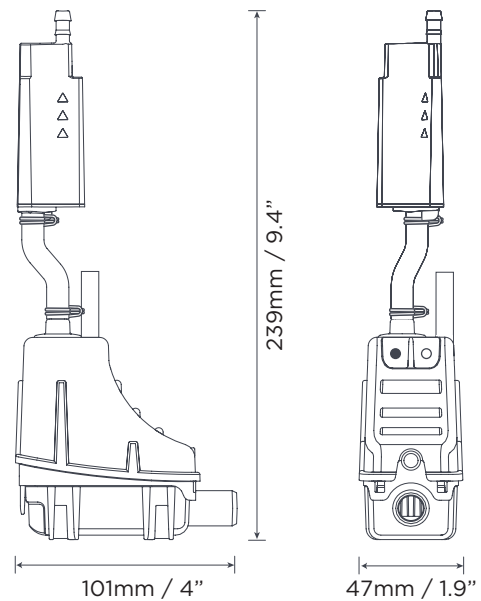

### SILENT+ MINI LIME

Max. flow	12L/h @ 0 head
Max. rec. head	10m
dB(A) @ 1m	20
Power supply	230 VAC, 0.1A, 16W, 50/60Hz
Rated	Non continuous
Max. water temp	40°C / 104°F
Discharge tube	6mm ID
IP Protection	IP24
Safety switch	5.0A Normally Closed/Open
Thermal protection	✓
Fully potted	✓
Self priming	✓

### SUGGESTED XTRA ACCESSORIES

DESCRIPTION	PART NO.
Vinyl Tube Braided (6mm)	AX5100



## Mini Blanc FP1080

### Condensate Removal Pump

The 'ultra quick fit' Mini Blanc is designed to be fitted beneath high wall indoor units and offers easy access for future maintenance.

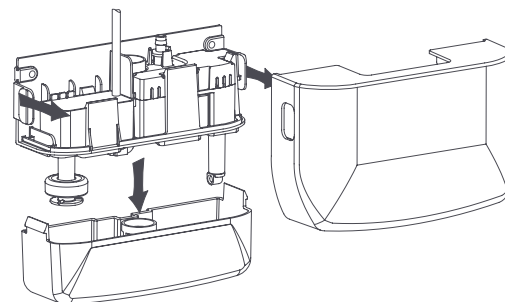
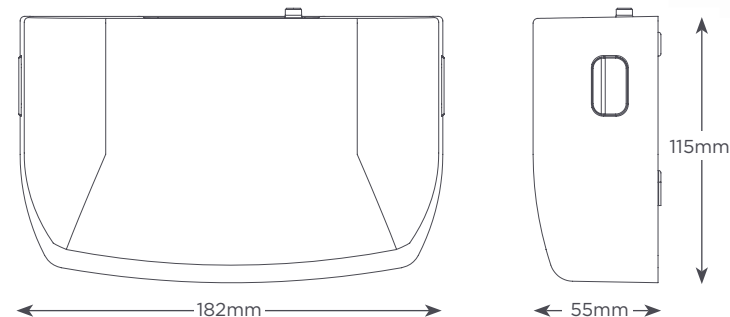

### Key features

- Extra quick to fit
- Compact & discreet
- Clear removable reservoir
- Quiet Operation

### Application

- High wall split systems
- Install below AC unit

#### MINI BLANC

Max. flow	12L/h @ 0 head
Max. rec. head	10m
Tank capacity	0.24L
dB(A) @ 1m	21
Power supply	230 VAC, 0.11A, 19W, 50/60Hz
Rated	Non continuous
Max. water temp	40°C / 104°F
Discharge tube	20mm in, 6mm out
IP Protection	IP21
Safety switch	3.0A Normally closed
Thermal protection	✓
Fully potted	Partially
Self priming	✓

#### SUGGESTED XTRA ACCESSORIES

DESCRIPTION	PART NO.
Mini Blanc Ivory Cover	FP1037
Vinyl Tube Braided (6mm)	AX5100



## Maxi Orange FP2210

### Condensate Removal Pump

Need more performance? Designed for larger units, the Maxi Orange pump gives you the extra power when you need it.

### Key features

- High vertical discharge
- Superior performance
- Submersible secondary reservoir included
- Anti-Siphon Device

### Application

- High wall split systems; Ducted units; Floor standing & Chassis units
- ✓ Perfect for: Large commercial units

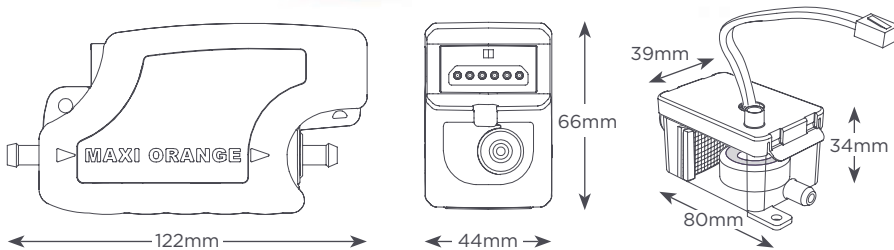

\*\*Anti-Siphon device to be installed on the discharge side of pump\*\*

MAXI ORANGE	
Max. flow	35L/h @ 0 head
Max. rec. head	15m
Max. suction lift	1.5m
dB(A) @ 1m	35
Power supply	230 VAC, 0.11A, 16W, 50/60Hz
Rated	Non continuous
Max. water temp	40°C / 104°F
Discharge tube	6mm ID
IP Protection	IP21
Safety switch	3.0A Normally closed
Thermal protection	✓
Fully potted	✓
Self priming	✓

SUGGESTED XTRA ACCESSORIES	
DESCRIPTION	PART NO.
Vinyl Tube Braided (6mm)	AX5100



## Maxi Lime FP2213

### Condensate Removal Pump

Designed for larger units & humid environments. The Maxi Lime pump gives you supreme power when needed.

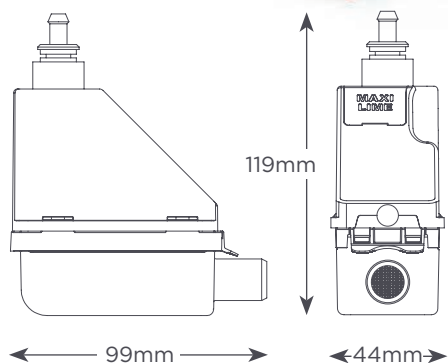

### Key features

- Sits in trunking elbow
- Left or right install
- Easy access for servicing
- 800mm Trunking

### Application

- High wall split systems
- Install on internal wall next to AC unit (with paircoil)

#### MAXI LIME

Max. flow	35L/h @ 0 head
Max. rec. head	15m
dB(A) @ 1m	35
Power supply	230 VAC, 0.1A, 16W, 50/60Hz
Rated	Non continuous
Max. water temp	40°C / 104°F
Discharge tube	6mm ID
IP Protection	IP24
Safety switch	3.0A Normally closed
Thermal protection	✓
Fully potted	✓
Self priming	✓

#### SUGGESTED XTRA ACCESSORIES

DESCRIPTION	PART NO.
Vinyl Tube Braided (6mm)	AX5100



# Selecting The Right Aspen Pump

## Where is the pump going to be installed?

### Hi Wall Split A/C

In the ceiling - **mini/maxi orange**

Behind the indoor unit - **mini aqua**

Under the indoor unit - **mini blanc**

In pipe duct with pipe - **mini/maxi lime**

### Ducted A/C

In the ceiling - **MAX Hi Flow / Mini Tank / Hi Lift Tank**

## What size is the air conditioner in kW?

For every kW of cooling an air conditioner can produce 1-1.5L of condensate per hour (LPH)

Example (using 1LPH): 5kW unit = 5LPH

\*Please note: Condensate output can vary greatly depending on environmental conditions like humidity. Please check local conditions and use 1.5+ LPH if required.

## How far must the pump lift the water?

A = vertical distance from condensate tray to inlet of pump

B = vertical distance from pump outlet

A + B = Meters of head

Example:

- A/C unit is 5kW cooling capacity

- Pump is located 1M above the indoor unit (suction lift)

- Water needs to be pumped 3M vertically from pump

- We need a pump that will pump 5L/hr at 4M head

## aspen performance chart // mini pumps

### mini blanc

### MAX VERTICAL HEAD 10m

Vertical Pumping Height (m)	0	1	2	4	6	8	10	-
Litres/hour	12	11	10	9	8	6	4	-

### mini orange // mini orange silent+

### MAX VERTICAL HEAD 10m

### MAX SUCTION LIFT 1.5m

Vertical Pumping Height (m)	0	1	2	4	6	8	10	-
Litres/hour	12	11	10	9	8	7	6	-

### mini aqua // mini aqua silent+

### MAX VERTICAL HEAD 10m

### MAX SUCTION LIFT 1.5m

Vertical Pumping Height (m)	0	1	2	4	6	8	10	-
Litres/hour	12	11	10	9	8	7	6	-

### mini lime silent+

### MAX VERTICAL HEAD 10m

Vertical Pumping Height (m)	0	1	2	4	6	8	10	-
Litres/hour	12	11	10	9	8	7	6	-

### maxi lime

### MAX VERTICAL HEAD 15m

Vertical Pumping Height (m)	0	1	2	4	6	8	10	12
Litres/hour	35	32	28	24	21	19	17	14

### maxi orange

### MAX VERTICAL HEAD 15m

### MAX SUCTION LIFT 1.5m

Vertical Pumping Height (m)	0	1	2	4	6	8	10	12
Litres/hour	35	32	28	24	21	19	17	14

\* mini orange silent+ recommended for noise sensitive areas

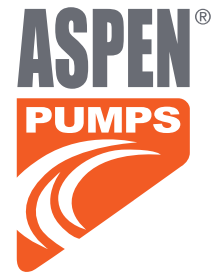

# Tank Pumps

Our tank pump range is designed with you, the installer in mind. Easy to install and maintain, with features including easy clean tank, plug & plug, twist & click non return valve and built in spirit level.

Easy maintenance

Time saving

High performance

Industry leading

## aspen performance chart // tank pumps

max hi flow (using 10mm tubing)		MAX VERTICAL HEAD 5m						
Vertical Pumping Height (m)	0	1	2	3	4	6	8	10
Litres/hour	550	490	400	300	200	-	-	-

mini tank pump		MAX VERTICAL HEAD 15m						
Vertical Pumping Height (m)	0	1	2	3	4	6	8	10
Litres/hour	35	32	28	26	24	22	19	17

hi lift 1L // hi lift 2L		MAX VERTICAL HEAD 12m						
Vertical Pumping Height (m)	0	1	2	3	4	6	8	10
Litres/hour	11	11	11	11	11	11	11	11

For every kW of cooling an air conditioner can produce 1-1.5L of condensate per hour (LPH) **Example** (using 1LPH): 5kW unit = 5LPH

\*Please note: Condensate output can vary greatly depending on environmental conditions like humidity. Please check local conditions and use 1.5+ LPH if required.



## MAX Hi-Flow FP3349

### Condensate Removal Pump

The best in class Max Hi-Flow tank pump carries on the Aspen Pumps tradition of build quality & high performance. With the lowest dB(A) rating of any tank pump, the Max Hi-Flow is the quietest & safest pump in its class.

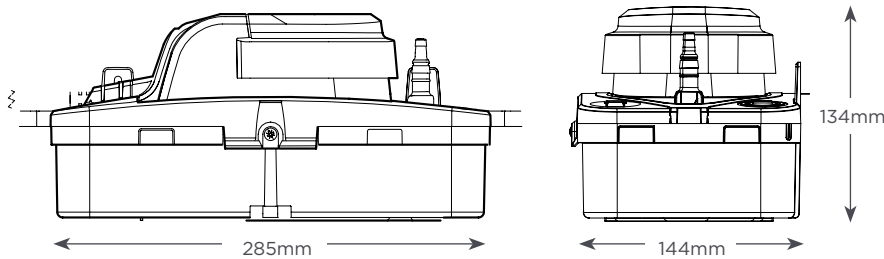
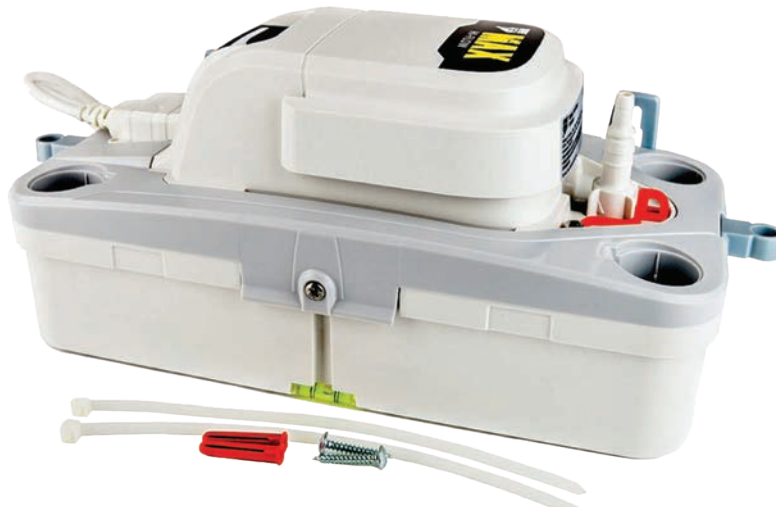

Non-return valve can be cut from 6mm to 10mm

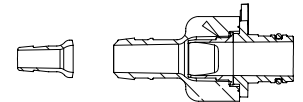

### Key features

- IP24 - Splash proof
- Easy access tank
- Built in spirit level
- Plug & play
- 550 Litres/Hour

### Application

- Ducted units

#### MAX HI-FLOW (10mm FLOW)

<b>Max. flow</b>	550L/h @ 0 head
<b>Max. rec. head</b>	5m
<b>Tank capacity</b>	1.7L
<b>dB(A) @ 1m</b>	44
<b>Power supply</b>	230 VAC, 0.8A, 50Hz
<b>Rated</b>	Non continuous
<b>Class</b>	I appliance
<b>Max. water temp</b>	40°C / 104°F
<b>Inlets</b>	x4 21-27mm
<b>Outlets</b>	6mm & 10mm
<b>IP Protection</b>	IP24
<b>Safety Switch</b>	3A Normally closed
<b>Thermal protection</b>	✓

#### IN THE BOX

Max Hi-Flow tank pump • Plug & Play power cable • Fixing kit incl. rod mount and wall mount clips • Install manual

#### SUGGESTED XTRA ACCESSORIES

DESCRIPTION	PART NO.
Rubber adaptor	FP2013
Vinyl Tube Braided 6mm	AX5100
Vinyl Tube Braided 10mm	AX5101





## Mini Tank FP1056

### Condensate Removal Pump

The new and improved Mini Tank pump can be wall mounted, floor mounted, in-pan or suspended on M8/M10 rod. Using piston technology this is a compact, powerful and multi functional tank pump.

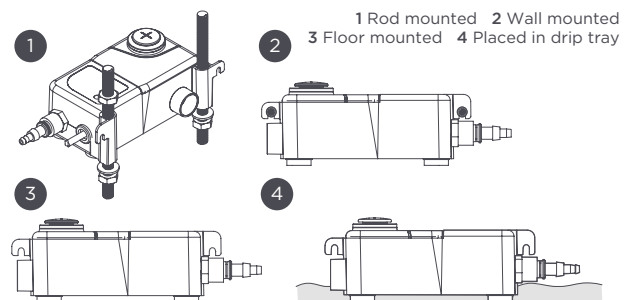
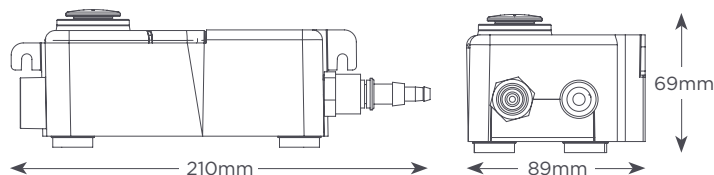

### Key features

- IP65 rated - Water resistant
- Four ways to install
- Compact & discreet
- Can be located in drain pan
- Easy maintenance

### Application

- Ducted units
- Cassette units
- ✓ Perfect for: Installation versatility

#### MINI TANK

Max. flow	35L/h @ 0 head
Max. rec. head	15m
Tank capacity	0.24L
dB(A) @ 1m	35
Power supply	230 VAC, 0.1A, 16W, 50/60Hz
Rated	Non continuous
Max. water temp	40°C / 104°F
Inlets	x2 22mm, 12mm & 27mm
Outlets	6mm & 10mm
IP Protection	IP65
Safety Switch	3.0A Normally closed
Thermal protection	✓
Fully potted	✓

#### IN THE BOX

Mini Tank pump (including hard wired 1.5m power cable) • x2 Rubber adaptors (21.5mm & 31mm) • Anti siphon device • Fixing kit • Install manual

#### SUGGESTED XTRA ACCESSORIES

DESCRIPTION	PART NO.
Tank pump connector 16mm-21mm	FP2011
Tube To Soil Stack Adaptor	FP2038
Vinyl Tube Braided 6mm	AX5100
Vinyl Tube Braided 10mm	AX5101

† Pump only



## Hi-Lift 1L & 2L

### Condensate Removal Pump

The Aspen peristaltic tank pump offers unmatched reliability when high vertical discharge is required.

### Key features

- High vertical discharge
- Easy fit & maintenance
- Built in spirit level

### Application

- Ducted units
- Cassette units

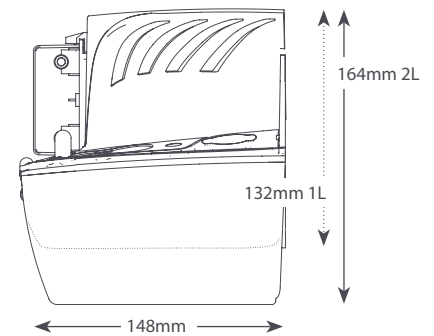
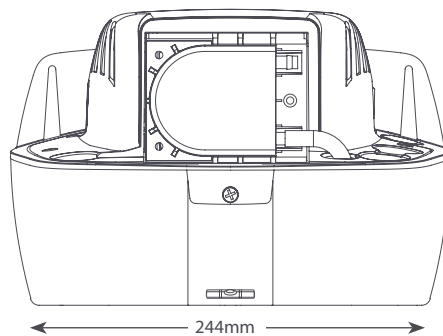

HI-LIFT 1L & 2L	
Max. flow	11L/h @ 12m head
Max. rec. head	12m
Tank capacity	1L & 2L
dB(A) @ 1m	51
Power supply	230 VAC, 0.4A, 50/60Hz
Rated	Continuously
Max. water temp	40°C / 104°F
Inlet/Outlet	x3 25mm in, 6mm out
IP Protection	IP20
Safety Switch	3.0A Normally closed
Thermal protection	✓

HI-LIFT OPTIONS	
Hi-Lift 1L	FP2099
Hi-Lift 2L	FP2071

SUGGESTED XTRA ACCESSORIES	
DESCRIPTION	PART NO.
Tank pump connector 16mm-21mm	FP2011
Tube To Soil Stack Adaptor	FP2038
Vinyl Tube Braided (6mm)	AX5110



## Heavy Duty 6m & 10m

### Condensate Removal Pump

With an impressive flow rate, these robust and reliable Heavy Duty pumps are perfect for the rapid removal of large quantities of condensate water.

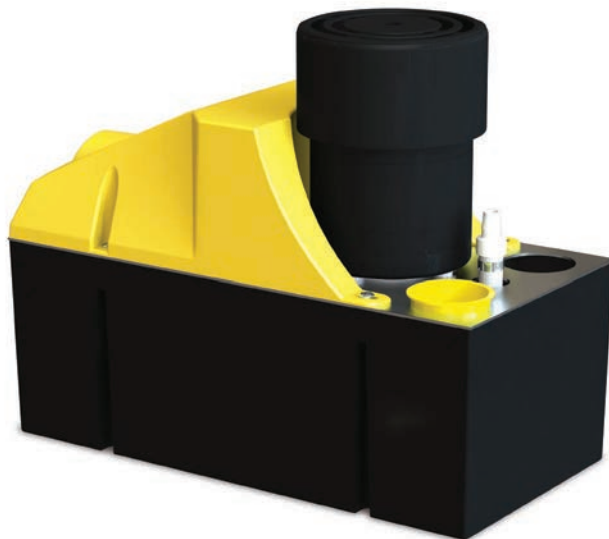

### Key features

- High flow rate
- Non return valve
- Easy installation
- 4 litre tank capacity

### Application

- Dehumidifiers; Air handling units (AHUs)

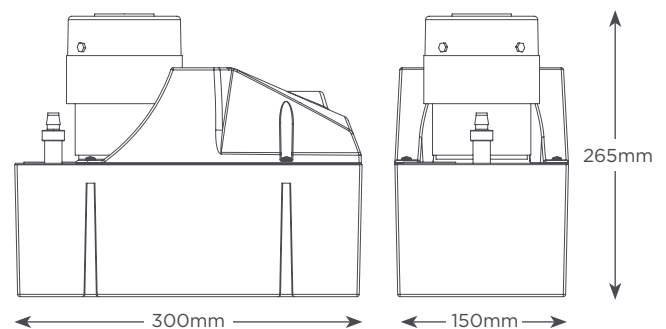
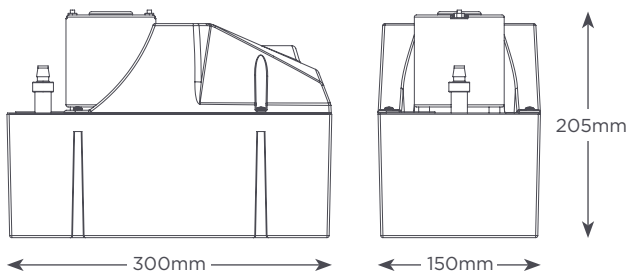

HEAVY DUTY 6 & 10	
<b>Max. flow</b>	HD6: 900L/h, HD10: 1070L/h
<b>Max. rec. head</b>	HD6: 6m, HD10: 10m
<b>Tank capacity</b>	4L
<b>dB(A) @ 1m</b>	HD6: 60, HD10: 64
<b>Power supply</b>	HD6: 230 VAC, 1.5A, 50Hz HD10: 230 VAC, 0.38A, 50Hz
<b>Rated</b>	HD6: Non continuous HD10: Continuous
<b>Max. water temp</b>	40°C / 104°F
<b>Inlet/Outlet</b>	x2 40mm in, 10mm out
<b>IP Protection</b>	IP20
<b>Safety Switch</b>	3.0A Normally closed

HEAVY DUTY OPTIONS	
Heavy Duty 6	FP2074
Heavy Duty 10	FP2066

SUGGESTED XTRA ACCESSORIES	
DESCRIPTION	PART NO.
Pipe to Pipe connector 21-40mm	FP2018
Tube To Soil Stack Adaptor	FP2038
Vinyl Tube Braided 10mm	AX5101



## Hot Water Economy FP2092

### Condensate Removal Pump

Built of heat resistant cycoloy, this economy pump is designed to handle high water temperatures.



### Key features

- High performance
- Handles 100°C water
- 2 inlets

### Application

- Humidifiers; Boilers; Refrigeration; Air handling units (AHUs)

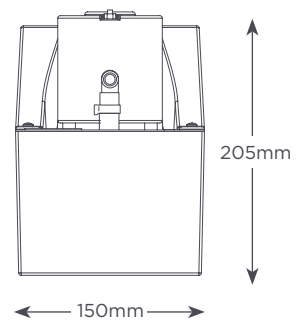
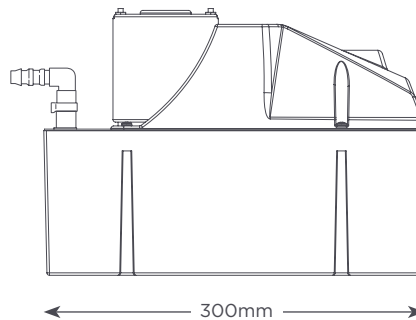
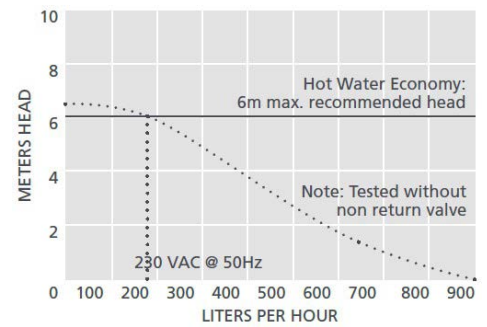

HOT WATER ECONOMY	
Max. flow	900L/h @ 0 head
Max. rec. head	6m
Tank capacity	4L
dB(A) @ 1m	60
Power supply	230 VAC, 1.5A, 50Hz
Rated	Non continuous
Max. water temp	100°C / 212°F
Inlet/Outlet size	x2 40mm in, 10mm out
IP Protection	IP20
Safety Switch	3.0A Normally closed
Thermal protection	✓

SUGGESTED XTRA ACCESSORIES	
DESCRIPTION	PART NO.
Tank pump connector 16-21mm	FP2011
Tube To Soil Stack Adaptor	FP2038
Vinyl Tube Braided 10mm	AX5101



# Hot Water Heavy Duty FP2132

## Condensate Removal Pump

The Hot Water Heavy Duty pump is designed to handle 80°C water and with an outstanding 1800L/h water flow rate.



### Key features

- High flow rate
- Handles 80°C water
- Non return valve
- Easy installation

### Application

- Air handling units (AHUs); Humidifiers, Boilers; Refrigeration

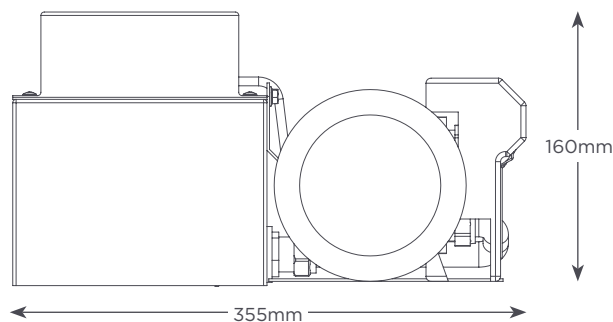
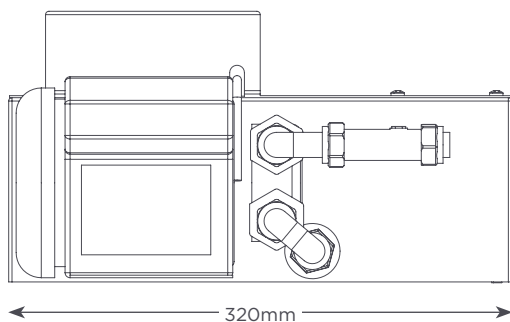
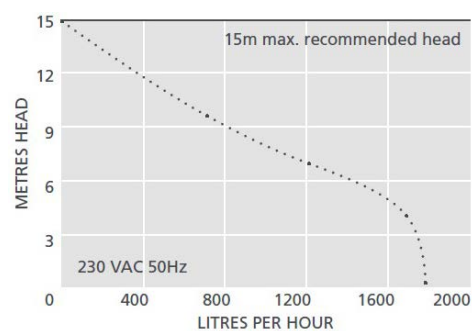

HOT WATER HEAVY DUTY	
Max. flow	1800L/h @ 0 head
Max. rec. head	15m
Tank capacity	5L
dB(A) @ 1m	63
Power supply	230 VAC, 1.5A, 50/60Hz
Rated	Continuously
Max. water temp	100°C
Inlet/Outlet size	x2 40mm in, 15mm out
IP Protection	IP21
Safety Switch	3.0A Normally closed
Thermal protection	✓

SUGGESTED XTRA ACCESSORIES	
DESCRIPTION	PART NO.
Pipe to Pipe adaptor 21-40mm	FP2018
Vinyl Tube Braided 10mm	AX5101

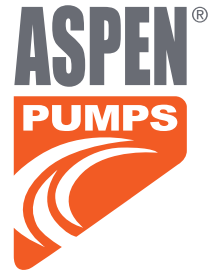

# Peristaltic Pumps

Our peristaltic pump range is perfect for spaces which require unobtrusive maintenance access (eg hotels, hospitals). Handling dirty water and with the added benefit that they can run dry, our peristaltic pump range is ideal for commercial remote applications.

Remote install

Ultra reliable

Constant flow rate

Can run dry

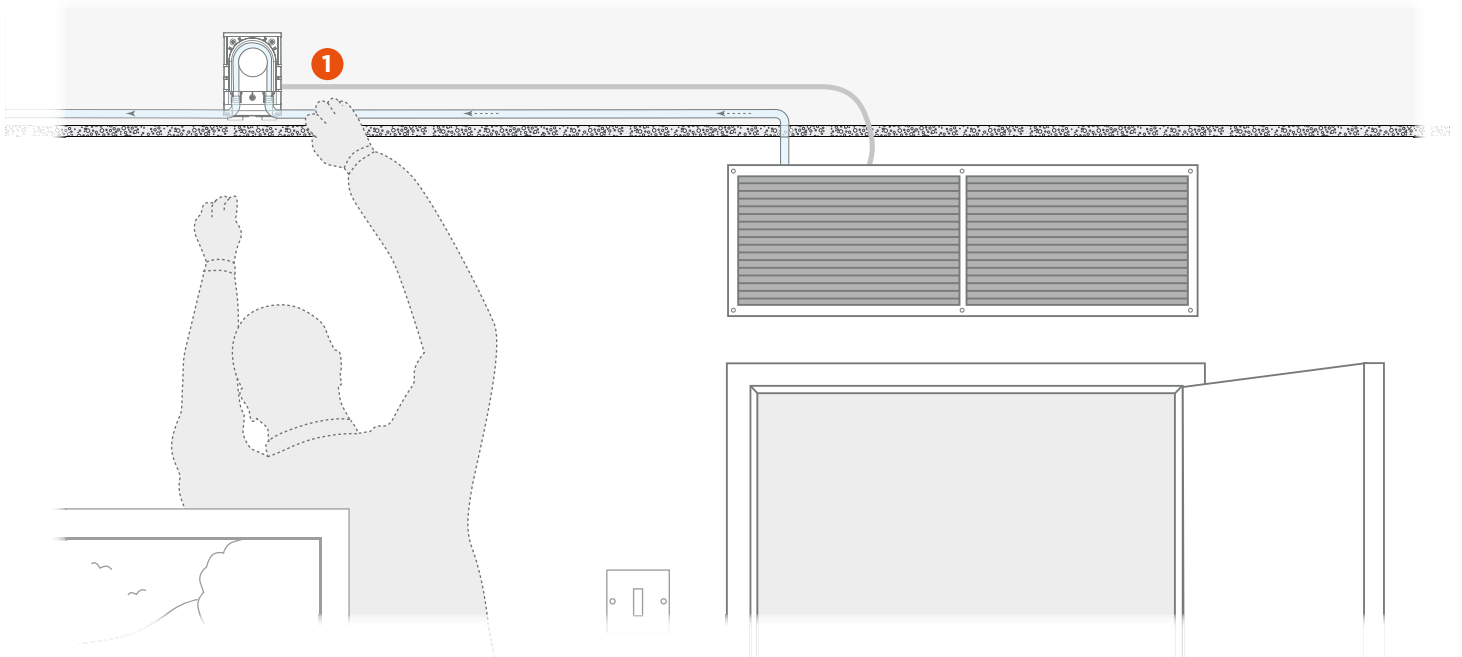

1 Remote access with minimal disturbance. Pump placed remotely from AC unit eg. above ceiling in hallway of hotel



## Universal FP2082

### Condensate Removal Pump

The top selling Universal is operated by two air temperature sensors. The peristaltic rotary movement creates a continuous pressure meaning the pump can be sited 8m away from the source with no effect in performance.

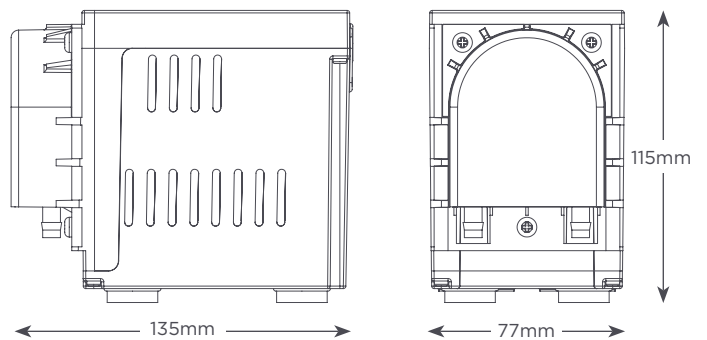

### Key features

- Air temp. sensor operated
- Remote install possible
- High vertical discharge
- Can run dry

### Application

- High wall split systems

#### UNIVERSAL

Max. flow	6.5L/h @ 12m head
Max. rec. head	12m
Max. suction lift	3m
dB(A) @ 1m	47
Power supply	230 VAC, 0.2A, 50/60Hz
Rated	Continuously
Max. water temp	40°C / 104°F
Inlet/Outlet	6mm ID
IP Protection	IP21
Thermal protection	✓
Self priming	✓

#### SUGGESTED XTRA ACCESSORIES

DESCRIPTION	PART NO.
Peri Spare Tube Kit	FP1282
Vinyl Tube Braided 6mm	AX5100



## Standard FP2081

### Condensate Removal Pump

Activated by an air conditioning cooling signal, the Standard peristaltic sets the standard for reliability. The remote install options means minimum future maintenance disruption.



### Key features

- AC cooling signal operated
- Remote install possible
- High vertical discharge
- Can run dry

### Application

- High wall split systems

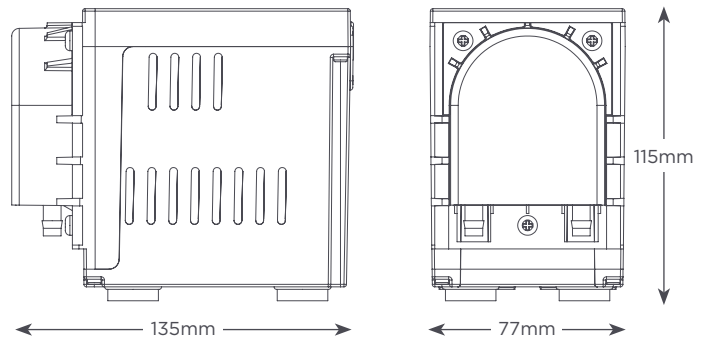

STANDARD	
Max. flow	6.5L/h @ 12m head
Max. head	12m
Max. suction lift	3m
dB(A) @ 1m	47
Power supply	230 VAC, 0.2A, 50-60Hz
Rated	Continuously
Max. water temp	40°C / 104°F
Inlet/Outlet	6mm ID
IP Protection	IP21
Thermal protection	✓
Self priming	✓

SUGGESTED XTRA ACCESSORIES	
DESCRIPTION	PART NO.
Peri Spare Tube Kit	FP1282
Vinyl Tube Braided 6mm	AX5100





## Mechanical

### Condensate Removal Pump

Bringing mini pump and peristaltic pump technology together. Simply position the remote reservoir (float switch) in the condensate tray or fix to the drain-pipe connection (depending on chosen reservoir).

\*Alarm option also available

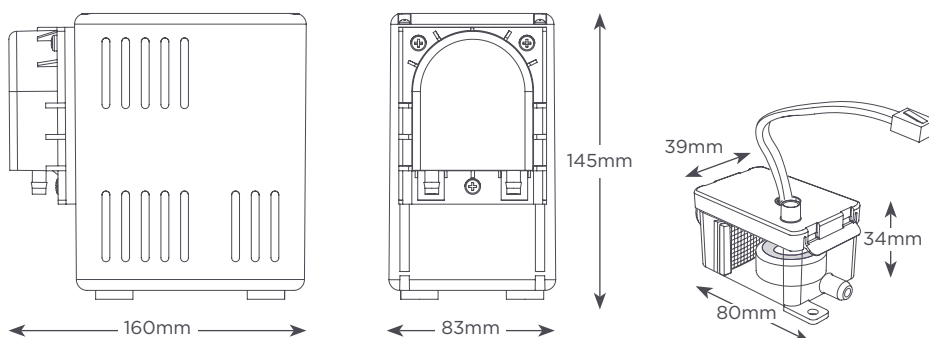

### Key features

- Float switch operated
- Remote install possible
- Submersible secondary reservoir included
- High vertical discharge

### Application

- High wall split systems

#### MECHANICAL

Max. flow	6.5L/h @ 12m head
Max. rec. head	12m
Max. suction lift	3m
dB(A) @ 1m	47
Power supply	230 VAC, 0.2A, 50/60Hz
Rated	Continuously
Max. water temp	40°C / 104°F
Inlet/Outlet	6mm ID
IP Protection	IP21
Safety switch	FP2079 only
Thermal protection	✓
Self priming	✓

#### MECHANICAL OPTIONS

Mechanical	FP2078
Mechanical with alarm	FP2079

#### SUGGESTED XTRA ACCESSORIES

DESCRIPTION	PART NO.
Peri Spare Tube Kit	FP1282
Vinyl Tube Braided 6mm	AX5100

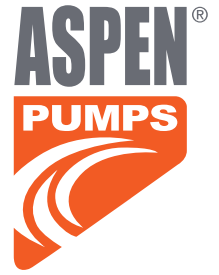

# Supermarket Pumps

Designed for commercial refrigeration units, this range of pumps is extremely easy to install and maintain. Placed directly below the refrigeration unit they remove water during the defrost cycle. The Low Profile ERRP, ERRP and Cold Cabinet all feature a unique debris filter, whilst the Macerator features a filter blade to stop the pumps from clogging with food debris.

Filters debris

Easy to clean

Large capacity

Multiple inlet options

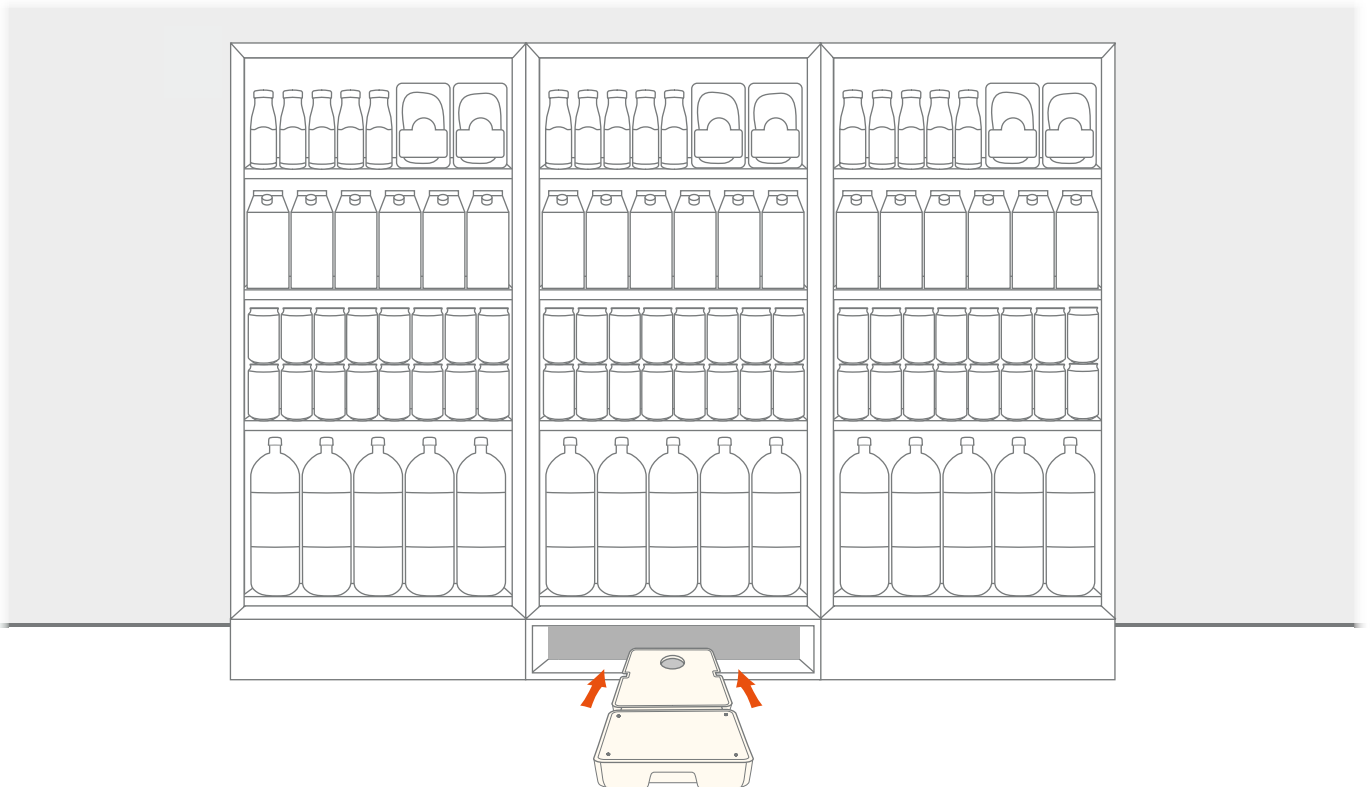



## Low Profile ERRP

### Condensate Removal Pump

Designed exclusively to fit underneath retail refrigeration cabinets the lightweight plastic ERRP (Economical Retail Refrigeration Pump) allows for the removal of defrosted and contaminated water.



### Key features

- Lightweight & slim
- Easy to clean
- Filter to catch debris
- Plug & play

### Application

- Refrigeration units; cold store cabinets

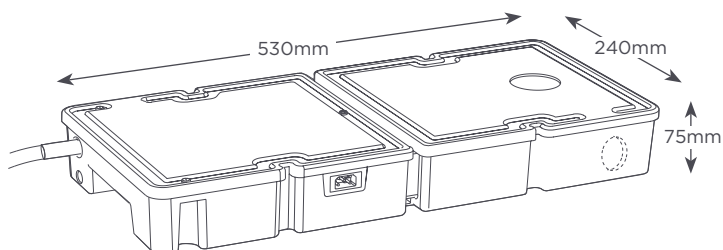

#### LOW PROFILE ERRP

Max. flow	190L/h @ 0 head
Max. rec. head	21m
Tank capacity	3.5L
dB(A) @ 1m	60
Power supply	230 VAC, 0.2A, 50/60Hz
Rated	Non continuous
Max. water temp	40°C / 104°F
Inlet/outlet	50mm in, 10mm out
IP Protection	IP24
Safety switch	3.0A Normally closed
Thermal protection	✓

#### LOW PROFILE ERRP OPTIONS

Low Profile ERRP – top inlet	FP2597
Low Profile ERRP – side inlet	FP2805

#### SUGGESTED XTRA ACCESSORIES

DESCRIPTION	PART NO.
Vinyl Tube Braided 10mm	AX5101



## ERRP FP2318 (Top Inlet)

### Condensate Removal Pump

Made of robust plastic, the lightweight ERRP (Economical Retail Refrigeration Pump) effectively pumps away defrosted water and filters debris.

### Key features

- High flow rate
- Easy to clean
- Filter to catch debris
- Plug & play

### Application

- Refrigeration units; cold store cabinets

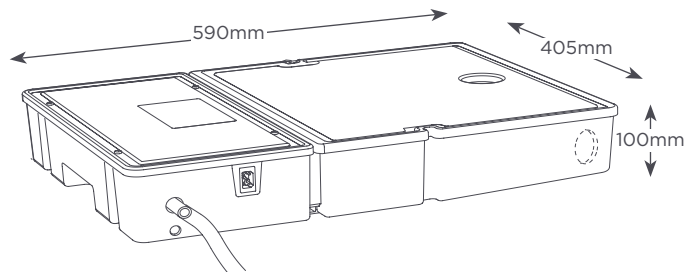

ERRP	
Max. flow	225L/h @ 0 head
Max. rec. head	35m
Tank capacity	11L
dB(A) @ 1m	60
Power supply	230 VAC, 0.2A, 50/60Hz
Rated	Non continuous
Max. water temp	40°C / 104°F
Inlet/outlet	50mm in, 10mm out
IP Protection	IP24
Safety switch	3.0A Normally closed
Thermal protection	✓

SUGGESTED XTRA ACCESSORIES	
DESCRIPTION	PART NO.
Vinyl Tube Braided 10mm	AX5101



## Low Profile Cold Cabinet

### Condensate Removal Pump

Made from robust stainless steel, this pump is extremely easy to install and maintain. With a feature designed to keep waterways moving, reducing the opportunity for biofilm to settle, the pump is placed directly below retail refrigeration cabinets removing condensate during the defrost cycle.

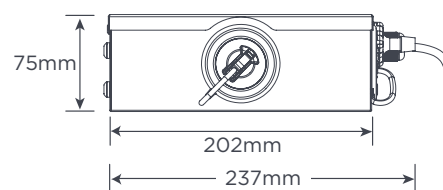
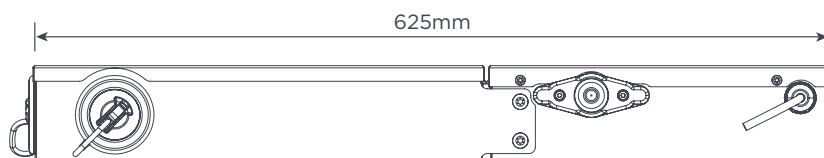

### Key features

- Integrated jet flow dispersal system to reduce biofilm build up
- Robust, abrasion resistant stainless steel casing
- Multiple inlets for flexible installation (top, end & both sides)
- Shallow 75mm height, lower than traditional dairy units
- Removable barbed brass outlet connector for ease of maintenance
- Highest performing Aspen refrigeration pump

### Suitability

- Refrigeration units, OEM
- **Perfect for...**refrigeration units with shallow access



#### COLD CABINET

Max. flow	700L/h @ 0 head
Max. head	20m (Rec. max. 18m)
Tank capacity	4.6L
dB(A) @ 1m	60
Power supply	230 VAC, 0.6A, 50/60Hz
Rated	Non continuous
Max. water temp	40°C / 104°F
Inlet	4x 8mm inlet holes with plugs
Outlet	10mm / 12mm
IP Protection	IP44
Safety switch	1A Normally closed
Thermal protection	✓

#### COLD CABINET OPTIONS

LP Cold Cabinet – top, end and both side inlets FP3393

#### SUGGESTED XTRA ACCESSORIES

DESCRIPTION	PART NO.
Vinyl Tube Braided 10mm	AX5101



## Macerator 4L & 10L

### Condensate Removal Pump

Designed to collect defrosted water from multiple refrigeration cabinets. The internal filter blade prevents the pumps from clogging, allowing longer intervals between maintenance visits.

### Key features

- Internal filter blade
- High flow & head
- Hi-level safety switch
- Low maintenance

### Application

- Single and multiple refrigeration units
- ✓ Perfect for: handling food waste that may pass through the pump

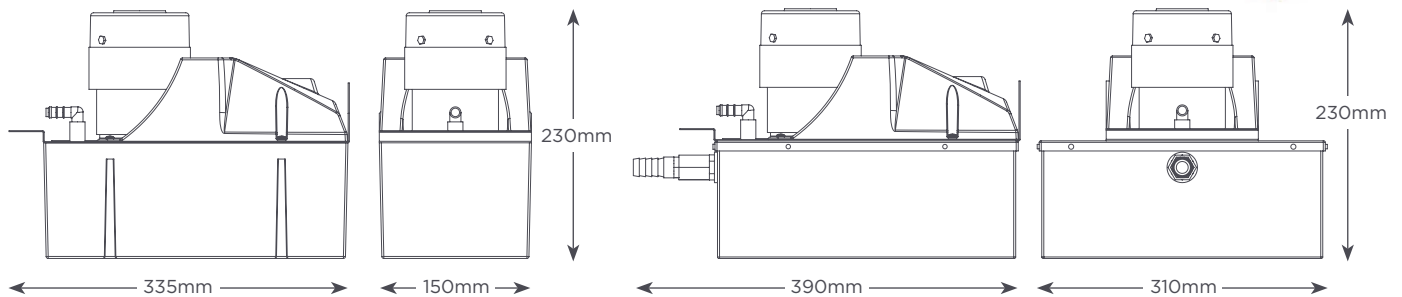

#### MACERATOR 4L & 10L

<b>Max. flow</b>	780L/h @ 0 head
<b>Max. rec. head</b>	8.5m
<b>Tank capacity</b>	4L & 10L
<b>dB(A) @ 1m</b>	64
<b>Power supply</b>	230 VAC, 0.38A, 50/60Hz
<b>Rated</b>	Non continuous
<b>Max. water temp</b>	40°C / 104°F
<b>Inlet/outlet</b>	x2 40 & 55mm in, 10mm out
<b>Additional inlet</b>	3/4" in tank (10L only)
<b>IP Protection</b>	4L & 10L: IP21
<b>Safety switch</b>	4.0A Normally closed
<b>Thermal protection</b>	✓

#### MACERATOR 4L & 10L OPTIONS

Macerator 4L	FP2305
Macerator 10L	FP2307

#### SUGGESTED XTRA ACCESSORIES

DESCRIPTION	PART NO.
Vinyl Tube Braided 10mm	AX5101

# INTRODUCING **POLYBENDER**

Polybender is an internal copper tube bending system designed to quickly and easily create kink free bends in soft annealed copper pair coil. Can be left inside to protect copper tube during first fix construction.



**3 Metre Lengths** (in clear bags)  
**3/8" Yellow:** PB38-3M  
**1/2" Red:** PB12-3M  
**5/8" Blue:** PB58-3M  
**3/4" Green:** PB34-3M

**25 Metre Lengths** (on spool)  
**3/8" Yellow:** PB38-25M  
**1/2" Red:** PB12-25M  
**5/8" Blue:** PB58-25M  
**3/4" Green:** PB34-25M



QR Code to Polybenders on  
Aspen Pumps website

For more information visit  
[aspenpumps.com.au](http://aspenpumps.com.au)



**ASPEN  
PUMPS**  
ASIA PACIFIC



# AIR CONDITIONING MOUNTS

- 31** Brackets
- 35** Ground Mounts
- 38** Anti Vibration
- 42** Condenser Guards
- 44** Big Foot Systems





# Aircon Brackets

Our aircon brackets are adjustable and have been designed for quick and easy installation.

The range includes electro-galvanised steel with a powder coated finish and 304 grade stainless steel. All brackets include rust resistant fixings and rubber mounts for anti vibration.

## Pacific Wall Bracket

PART NO.	DESCRIPTION	WIDTH (A)	HEIGHT (B)	MAX LOAD
<b>PSGK81</b>	450mm Wall Bracket	800mm	380mm	100kg
<b>PSGKL83</b>	550mm Wall Bracket	800mm	420mm	150kg

\*Brackets also available without backplate





## AIR CONDITIONING MOUNTS

### Pacific Sloped Roof Bracket

The Pacific Sloped Roof Brackets are made of electro galvanized steel with a Powder Coated finish. They are highly adjustable and come with rubber mounts with ruspert treated bolts for anti corrosion.

PART NO.	DESCRIPTION	DEPTH (A)	WIDTH (B)
<b>PSGY1</b>	100kg Sloped Roof Bracket	400mm	730mm
<b>PSGYL1</b>	150kg Sloped Roof Bracket	750mm	600mm

#### PSGY1

Pitch: 15°-30°  
Mounted: Parallel to roof line

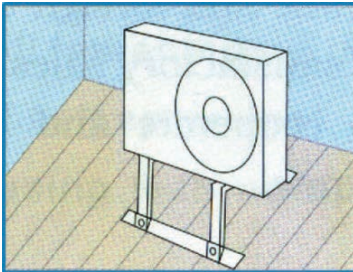

#### PSGYL1

Pitch: 0°-30°  
Mounted: 90° to roof line

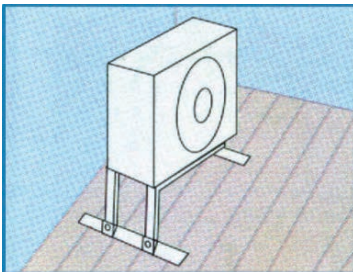

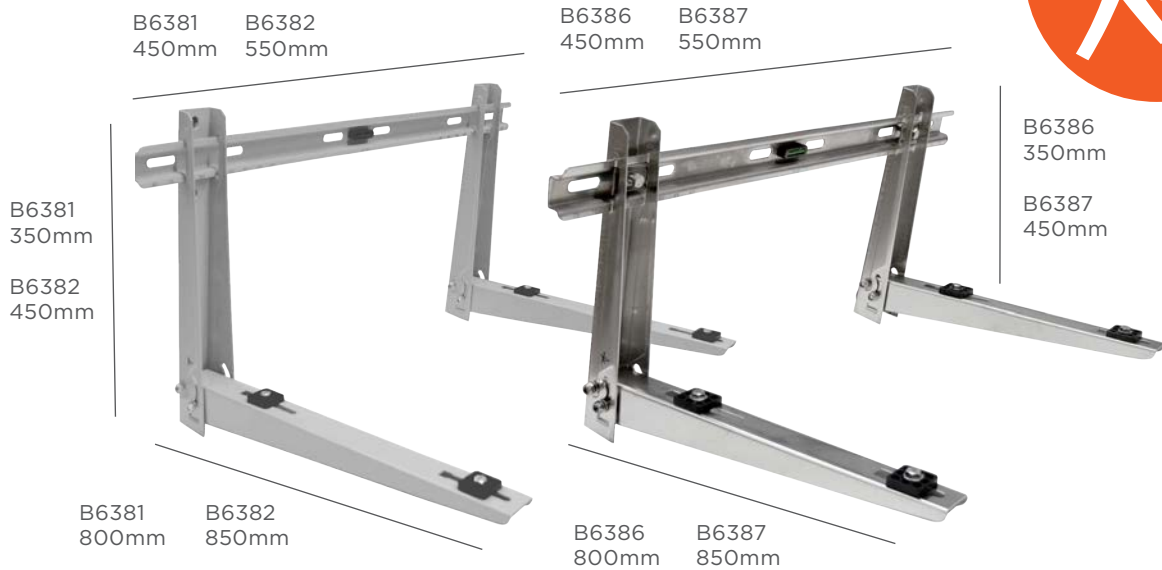

### Aspen Xtra Wall Brackets (Powder Coated)

PART NO.	DESCRIPTION	WIDTH	HEIGHT	MAX LOAD
<b>B6381</b>	450mm Wall Bracket	800mm	350mm	100kg
<b>B6382</b>	550mm Wall Bracket	850mm	450mm	150kg

### Aspen Xtra Wall Brackets (Stainless Steel)

PART NO.	DESCRIPTION	WIDTH	HEIGHT	MAX LOAD
<b>B6386</b>	450mm Wall Bracket	800mm	350mm	100kg
<b>B6387</b>	550mm Wall Bracket	850mm	450mm	150kg



### Aspen Xtra Sloped Roof Brackets (Powder Coated)

PART NO.	DESCRIPTION	DEPTH (A)	WIDTH (B)	PITCH
<b>B6388</b>	150kg Powder Coated Roof Bracket	220-500mm	1000mm	5-45°

### Aspen Xtra Sloped Roof Brackets (Stainless Steel)

PART NO.	DESCRIPTION	DEPTH (A)	WIDTH (B)	PITCH
<b>B6389</b>	150kg Stainless Steel Roof Bracket	220-500mm	1000mm	5-45°



## Cantilever Bracket Kit

The Pacific Cantilever Brackets are made from hot dip galvanised steel and come as a set of 2 with a complete mounting kit including wall fastenings and 4 purpose designed vibration mounts to suit 40mm channel.



PART NO.	DESCRIPTION	HEIGHT	MAX LOAD
CB450	450mm Cantilever Bracket Set	280mm	150kg
CB600	600mm Cantilever Bracket Set	280mm	150kg
CB750	750mm Cantilever Bracket Set	280mm	150kg

\*Single arms with no fixings/mounts available

## Cantilever Mounting Plate

The mounting plates allow a larger surface area for securing cantilever brackets.

Recommended for heavier unit installations.

PART NO.	DESCRIPTION
CB2M	2 x Cantilever Bracket Mounting Plate



## Level Surface Roof Mount

The LSC roof mount kit comes as a set with 4 pieces which allows adjustment from 0-20°. Simply adjust to the required pitch and secure in position with screws/bolts.

PART NO.	DESCRIPTION	SIZE
LSC	Level Support Channel Roof Mount	1200mm
LSC15	Level Support Channel Roof Mount	1500mm





# Ground Mounts

The Pro Pipe range of ground mounts offers a solution for almost every air conditioning installation placed on the ground.

## TuffSlab Eco+

The MOST sustainable and environmentally considered HVAC equipment slab available in the market.

The revolutionary TuffSlab Eco+ contributes to a circular economy by purely using industrial waste plastic to create the product.

Not only does this make TuffSlab Eco+ the most sustainable product in the market, but also the best value for money.

PART NO.	DESCRIPTION	MAX LOAD
TSLAB-MB	TuffSlab Eco+ Black - 900x430x50mm	160kg
TSLAB-MG	TuffSlab Eco+ Grey - 900x430x50mm	160kg

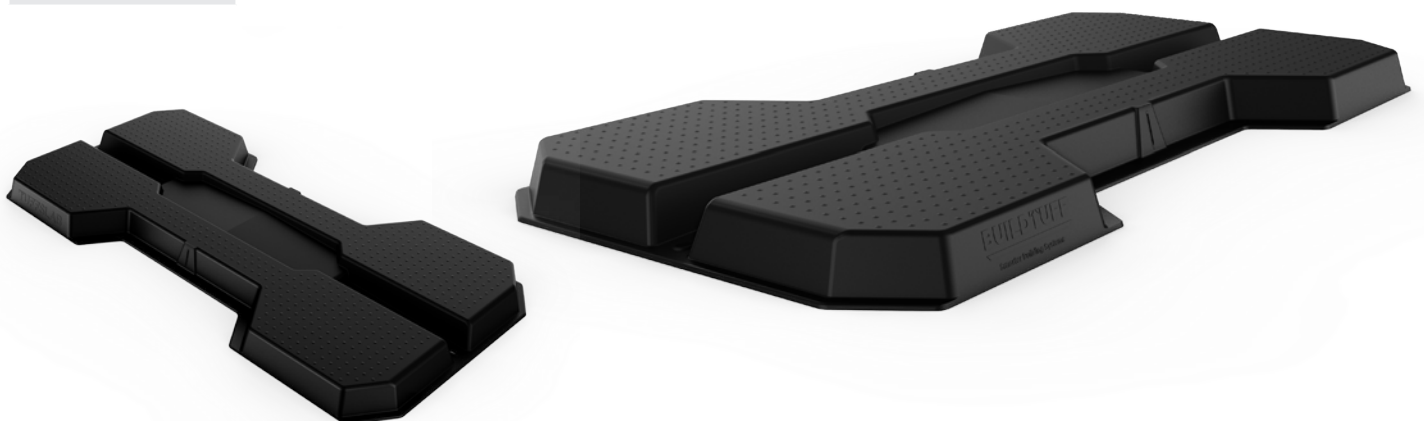



## AIR CONDITIONING MOUNTS

### Pacific Mounting Block

Produced with high quality PVC, our mounting blocks are shockproof and UV stabilized. Comes complete with mounting bolt and nuts, along with one end cap for each block.

PART NO.	DESCRIPTION	MAX LOAD PER SET	HEIGHT
PSR362	360mm Mounting Block	200kg	95mm
PSR452	450mm Mounting Block	200kg	95mm
MB1000	1000mm Mounting Block	200kg	95mm

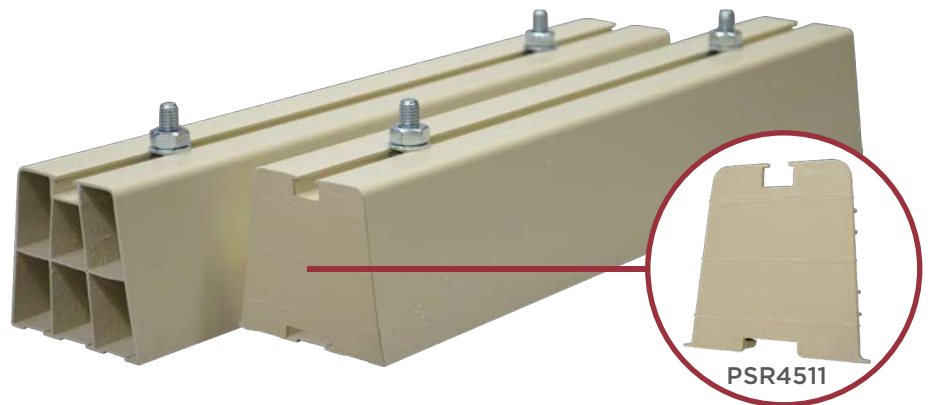

### Euro Mounting Block

Produced in high quality UV stabilized polypropylene, these mounting blocks come complete with screws, nuts and washers for unit installation.

PART NO.	DESCRIPTION	MAX LOAD PER SET	HEIGHT
IMB420	420mm Mount Block (2pk)	240kg	72mm





Aluminium  
channel is  
anchored into  
the rubber  
**NOT glued in**

Embedded aluminium channel

Environmentally friendly

Durable recycled rubber

## Fix It Foot

A sturdy support made from durable recycled rubber, with 40mm x 20mm channel.

Anti-vibration reduces noise levels.

PART NO.	DESCRIPTION	HEIGHT	WIDTH	MAX LOAD
<b>B6735</b>	250mm Fix It Foot	95mm	180mm	82kg
<b>B6736</b>	400mm Fix It Foot	95mm	180mm	128kg
<b>B6737</b>	600mm Fix It Foot	95mm	180mm	224kg
<b>B9096</b>	1000mm Fix It Foot	95mm	180mm	295kg

\*B9171A Fixing Bolt available (2pk)

## Fix It Foot (Low Profile)

PART NO.	DESCRIPTION	HEIGHT	WIDTH	MAX LOAD
<b>B9043</b>	250mm Fix It Foot	50mm	130mm	82kg
<b>B9045</b>	400mm Fix It Foot	50mm	130mm	128kg
<b>B9368</b>	500mm Fix It Foot	50mm	130mm	134kg



## Product Highlight



Set includes 2x B9368 and B9171A fixings





# Anti Vibration

Our high quality range of anti vibration mounts are designed to reduce noise and vibration.

We have a large range to allow for various installations. Fixings come with a rust resistant coating.

## Waffle Pad

The waffle pads have a grid pattern which make them virtually non-slip, they are also designed to minimize the transmission of shock, noise and vibration caused by machines including air conditioners.

Made from a neoprene/EPDM they are often used to compensate for unevenness between surfaces, whilst also providing a barrier to prevent the migration of moisture from the base to metallic machine parts.

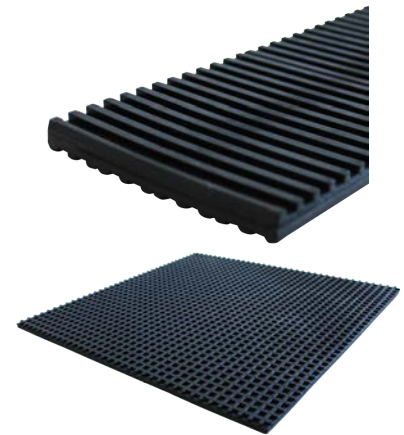

PART NO.	DESCRIPTION
VWP4545	10mm Waffle Pad Square (450mm x 450mm)
VWP10010	10mm Waffle Pad Strip (1000mm x 100mm)

## Ripper Waffle Pad

\*18 pieces per sheet w/pre drilled hole. Easy to tear off rectangles.

PART NO.	DESCRIPTION
VWP3030R	10mm Rippable Waffle Pad Square (300mm x 300mm)







## Vibration Mounts

Vibration mounts are made from rubber/EPDM designed specifically for mounting air conditioning units.

They are very sturdy and provide a great reduction to vibration and noise levels.

Max Load ratings based on a set of 4 mounts

PART NO.	DESCRIPTION	MAX LOAD (SET)
<b>VM1SQ</b>	Square Vibration Mount (H)25mm (4pk)	1000kg
<b>VM2</b>	Vibration Mount (H)50mm (4pk)	320kg
<b>VM3</b>	Vibration Mount (H)75mm (4pk)	320kg
<b>VM4</b>	Vibration Mount (H)91mm (4pk)	320kg
<b>VMP</b>	Vibration Mount Pad (4pk)	240kg
<b>VMCB</b>	40mm Strut/Channel Vibration Mount(4pk)	240kg
<b>VM400A</b>	Adjustable Mount (H)92mm (4pk)	200kg
<b>VM400HDG</b>	Adjustable Mount (H)92mm (4pk)	200kg

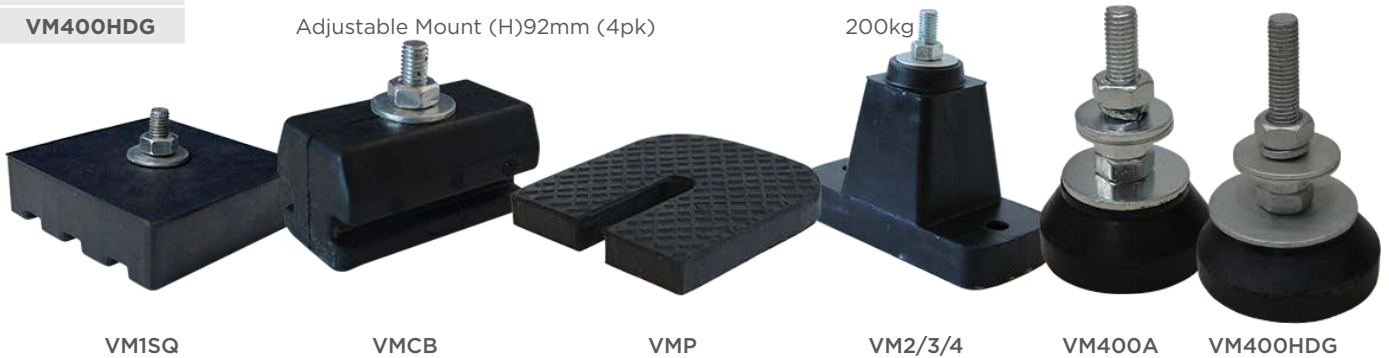

## Deflection Mounts

Our high quality range of anti vibration mounts are designed to reduce noise and vibration.

We have a large range to allow for various installations. Fixings come with a rust resistant coating.



THREAD	WHITE 20-45KG	RED 5-70KG	GREEN 50-100KG	BLUE 80-160KG	DEFLECTION
8mm	SNAW	SNAR	SNAG	SNAB	SINGLE
12mm	SNBW	SNBR	SNBG	SNBB	SINGLE
8mm	NAW	NAR	NAG	NAB	DOUBLE
12mm	NBW	NBR	NBG	NBB	DOUBLE
8mm	WBMW	WBMR	WBMG	WBMB	DOUBLE

\*Bolt included

THREAD	RED 65-130KG	GREEN 100-200KG	BLUE 150-300KG	YELLOW 250-500KG	DEFLECTION
16mm	NCR	NCG	NCB	NCY	DOUBLE

\*Bolt included



## AIR CONDITIONING MOUNTS

### M10 Rubber Hangers

Anti-vibration rubber hanger prevents the transfer of vibration generated by equipment to the structure.

80mm

PART NO.	DESCRIPTION
RH-A25100	M10 Rubber Hanger (25kg - 100kg)



### D30 Isolation Spring Mount

PART NO.	DESCRIPTION
ISO-D30	Isolation Spring Mount 32Kg For Small Air Handlers



### M10 Spring Hangers

High efficient vibration control when suspending air conditioning units, pipework and ducts, this prevents vibration transfer from equipment to the structure.

135mm

PART NO.	DESCRIPTION
VH-10	M10 Spring Hanger (10kg)
VH-25	M10 Spring Hanger (25kg)
VH-50	M10 Spring Hanger (50kg)
VH-75	M10 Spring Hanger (75kg)
VH-100	M10 Spring Hanger (100kg)





## Adjustable Seismic Mounts - Rated Capacity Guide

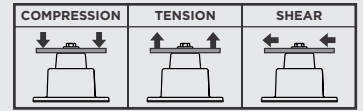

### 50mm High Seismic Mounts

PART NO.	DESCRIPTION	RATED CAPACITY		
		COMPRESSION N (KG)	TENSION N (KG)	SHEAR N (KG)
ASRM5040	40A Duro (Red) 50mm (H)	1000 (102)	500 (51)	250 (25)
ASRM5055	55A Duro (Yellow) 50mm (H)	2000 (204)	900 (92)	450 (46)
ASRM5070	70A Duro (No Colour) 50mm (H)	4000 (408)	1200 (122)	600 (61)



### 75mm High Seismic Mounts

PART NO.	DESCRIPTION	RATED CAPACITY		
		COMPRESSION N (KG)	TENSION N (KG)	SHEAR N (KG)
ASRM7540	40A Duro (Red) 75mm (H)	2000 (204)	1000 (102)	450 (46)
ASRM7555	55A Duro (Yellow) 75mm (H)	4000 (408)	1500 (153)	650 (66)
ASRM7570	70A Duro (No Colour) 75mm (H)	6000 (612)	2000 (204)	1100 (112)



### 100mm High Seismic Mounts

PART NO.	DESCRIPTION	RATED CAPACITY		
		COMPRESSION N (KG)	TENSION N (KG)	SHEAR N (KG)
ASRM10040	40A Duro (Red) 100mm (H)	4000 (408)	1500 (153)	800 (82)
ASRM10055	55A Duro (Yellow) 100mm (H)	8000 (816)	2500 (255)	1300 (133)
ASRM10070	70A Duro (No Colour) 100mm (H)	12000 (1224)	4000 (408)	2100 (214)



### 41mm Strut Seismic Mounts

PART NO.	DESCRIPTION	RATED CAPACITY		
		COMPRESSION N (KG)	TENSION N (KG)	SHEAR N (KG)
ASRMU4040	40A Duro (Red) 40mm Strut	700 (71)	130 (13)	110 (11)
ASRMU4055	40A Duro (No Colour) 40mm Strut	1500 (153)	200 (20)	170 (17)
ASRMU4070	40A Duro (No Colour) 40mm Strut	2000 (204)	350 (36)	230 (23)



### Hanging Adjustable Seismic Mounts

PART NO.	DESCRIPTION
TSRMU4040	40A Duro Strut Mount 10mm Threaded Rod (Red)
TSRMU404012	40A Duro Strut Mount 12mm Threaded Rod (Red)
TSRMU4055	55A Duro Strut Mount 10mm Threaded Rod (Yellow)
TSRMU405512	55A Duro Strut Mount 12mm Threaded Rod (Yellow)
TSRMU4070	70A Duro Strut Mount 10mm Threaded Rod (No Colour)
TSRMU407012	70A Duro Strut Mount 12mm Threaded Rod (No Colour)





# Condenser Guards

Easy & quick to install

Easy to handle

## Maximum Strength

- PROTECT Guards are made of Heavy Duty Angle Iron & 25mm steel mesh
- Hot Dipped Galvanised to last

## Maximum Security

- PROTECT Guards can be bolted to a wall or fastened to a concrete pad
- Padlock the front access panel for added security

## Maximum Standards

- PROTECT Guards comply to Government Specifications

## Condenser Guards

**Includes:** 2x Side Panels / 1x Front Panel / 1x Top Panel

PART NO.	DESCRIPTION (H x W x D)
ACG9	Air Con Guard (900mm x 1000mm x 600mm)
ACG10	Air Con Guard (1000mm x 1200mm x 600mm)
ACG12	Air Con Guard (1200mm x 1200mm x 600mm)
ACG14	Air Con Guard (1400mm x 1200mm x 600mm)
ACG16	Air Con Guard (1600mm x 1200mm x 600mm)
ACG20	Air Con Guard (2000mm x 1400mm x 900mm)

\*Back panels sold separately





## Rapid Fit Guards

Rapid Fit Guards deter vandalism and prevent damage to valuable equipment whilst still quick to install.

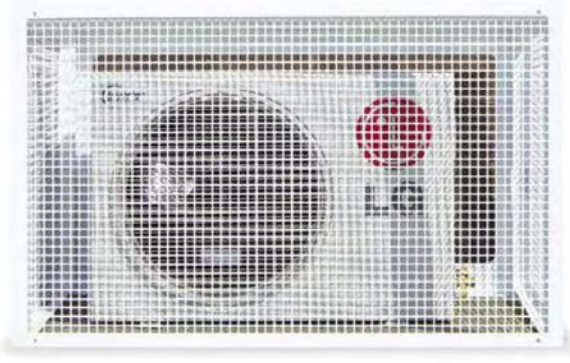

PART NO.	DESCRIPTION	SIZE
B9163	Small	Internal: 600mm(H) x 900mm(W) x 500mm(D)
B9164	Medium	Internal: 1000mm(H) x 1000mm(W) x 500mm(D)
B9165	Large	Internal: 1300mm(H) x 1000mm(W) x 500mm(D)

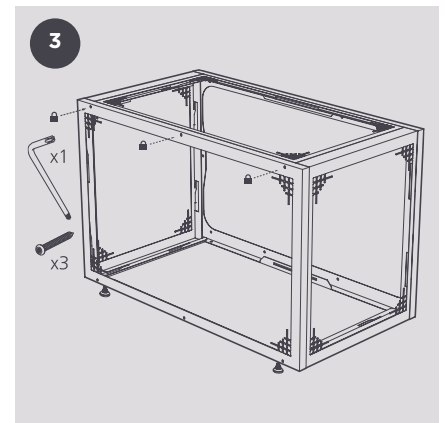
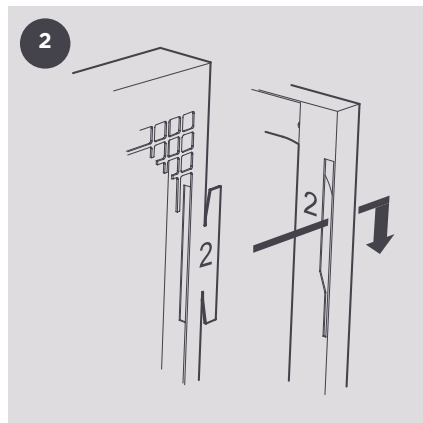
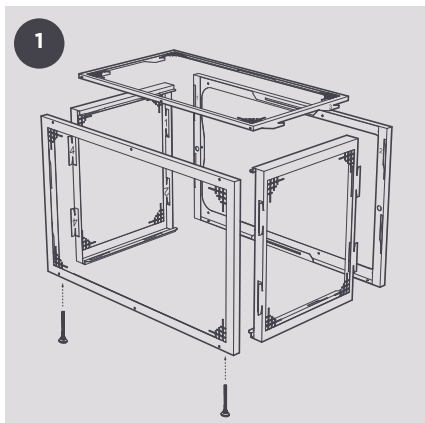



# Big Foot Systems

Our range of HVAC/R supports provides a quick to install, non-penetrative solution to suit all leading AC manufacturers units. Recycled rubber bases provide anti-vibration benefits.

## Multi Frame

The Multi Frame has the ability to extend from any side using the Extension Kit, giving you the flexibility to create the frame configuration to suit your install.



- Adjustable Height
- Highly customisable
- HDG frame and fixings
- Quick and easy to assemble
- Clamp kits included

PART NO.	DESCRIPTION	HEIGHT	LENGTH	MAX LOAD	WEIGHT	WIDTH
<b>B9720</b>	Multi Frame	335-440mm	1000mm	500kg	36kg	1200mm
<b>B9721</b>	Extension Kit	335-440mm	1000mm	500kg	26kg	1200mm
<b>B9731</b>	Multi Frame XL	335-440mm	1500mm	500kg	43kg	1200mm
<b>B9732</b>	Extension XL Kit	335-440mm	1500mm	500kg	33kg	1200mm



## HD Beams

The HD Beam enables the AHU/chiller to be positioned accurately, such as directly over existing structural beams, so the load can be evenly distributed.



Adjustable height

Non-penetrative

Boxed with beam clamps



**B9306**  
HD Clamp

PART NO.	DESCRIPTION	HEIGHT	MAX LOAD
<b>B9423</b>	450mm HD Beam	300-360mm	1000kg
<b>B9690</b>	450mm HD Beam (High)	300-560mm	1000kg

KIT INCLUDES	
Leg assembly	x2
Cross bar	x1
Beam clamps	x2
Assembly instructions	x1

## H Frame Set

H Frame Sets are an economical support solution for pipework, cable trays and metal duct work. Suits 20/40mm channel and is customisable on site to suit application.



\*Please note: Strut is not included in kit

Versatile application

Excellent load distribution

Boxed for convenience



PART NO.	DESCRIPTION	MAX LOAD
<b>B6088</b>	305mm Small H-Frame (2pk)	300kg

KIT INCLUDES
Foot with AV rubber mat x2
Bracket & fixings
Assembly instructions



## AIR CONDITIONING MOUNTS



Aluminium channel is anchored into the rubber  
**NOT glued in**

Embedded aluminium channel

Environmentally friendly

Durable recycled rubber

### Fix It Foot

A sturdy support made from durable recycled rubber, with 40mm x 20mm channel.

Anti-vibration reduces noise levels.

PART NO.	DESCRIPTION	HEIGHT	WIDTH	MAX LOAD
<b>B6735</b>	250mm Fix It Foot	95mm	180mm	82kg
<b>B6736</b>	400mm Fix It Foot	95mm	180mm	128kg
<b>B6737</b>	600mm Fix It Foot	95mm	180mm	224kg
<b>B9096</b>	1000mm Fix It Foot	95mm	180mm	295kg

\*Fixings not included | \*\*B9171A Fixing Bolt available (2pk)

### Fix It Foot (Low Profile)

PART NO.	DESCRIPTION	HEIGHT	WIDTH	MAX LOAD
<b>B9043</b>	250mm Fix It Foot	50mm	130mm	82kg
<b>B9045</b>	400mm Fix It Foot	50mm	130mm	128kg
<b>B9368</b>	500mm Fix It Foot	50mm	130mm	134kg



\*Fixings not included

### Product Highlight

#### B9368SET

PART NO.	DESCRIPTION
<b>B9368SET</b>	500 Low Profile Fix-It-Foot (Set of 2 + Fixings)

Set includes 2x B9368 and B9171A fixings





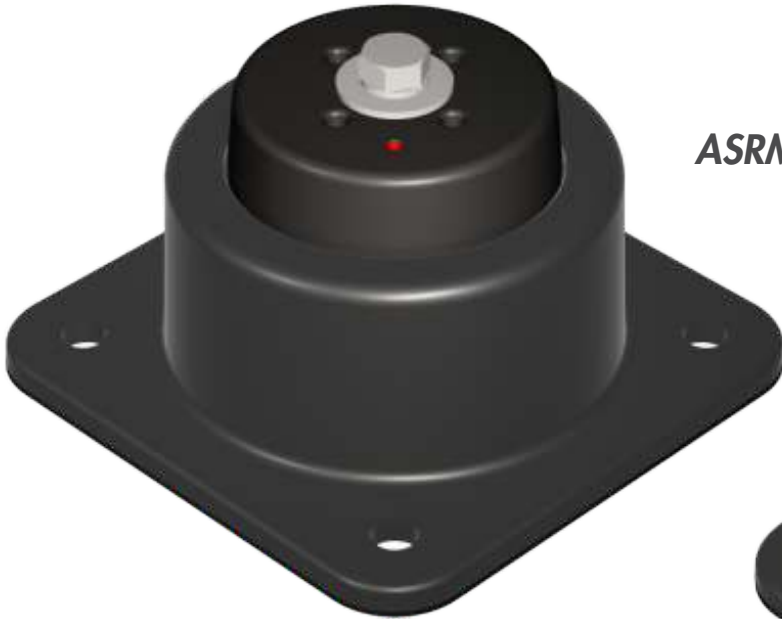

*ASRM - ADJUSTABLE SEISMIC RUBBER MOUNT*



**PATENTED DESIGNS!**



*TSRMU - TENSION SEISMIC RUBBER MOUNT*





# DUCT & FITTINGS

- 49** Pacific Duct
- 50** Pacific Fittings



# Pacific Duct

The Pro Pipe 'Pacific Duct' series has been designed for covering insulated copper pipe, drain pipe and electrical cable on an air conditioning installation.

Pacific Duct has been manufactured to be strong and easy to install, saving time on your job site.

## Pipe Duct

Used to conceal external pipework on aircon installations

**Temperature Rating:** -20°C / +70°C

PART NO.	DESCRIPTION	QTY/BULK
PSD7	75mm Pipe Duct - 2m	5/245
PSD10	100mm Pipe Duct - 2m	5/180

\*UV Stabilised and temperature rated up to 70°C

Pacific  
Duct is UV  
stabilised





## Wall Inlet

Perfect for duct closure. Design features a wide frame for full pipe inlet coverage



PART NO.	DESCRIPTION	QTY/CTN
PSW7	75mm Wall Inlet (2 Piece)	10/60
PSW10	100mm Wall Inlet (2 Piece)	10/40

PART NO.	DESCRIPTION	QTY/CTN
PSWA7	75mm Wall Inlet (1 Piece)	10/60
PSWA10	100mm Wall Inlet (1 Piece)	10/40



## 90° Flat Elbow

Joins duct with a 90° flat bend



PART NO.	DESCRIPTION	QTY/CTN
PSK7	75mm Flat Elbow 90°	10/60
PSK10	100mm Flat Elbow 90°	10/40

## 45° Flat Elbow

Joins duct with a 45° flat bend



PART NO.	DESCRIPTION	QTY/CTN
PSKF7	75mm Flat Elbow 45°	10/60
PSKF10	100mm Flat Elbow 45°	10/40



## 90° Corner Elbow

Joins duct with a 90° external bend



PART NO.	DESCRIPTION	QTY/CTN
PSC7	75mm Corner Elbow 90°	10/60
PSC10	100mm Corner Elbow 90°	10/40

## Ceiling Cap

Covers installation holes in ceilings and roof eaves



PART NO.	DESCRIPTION	QTY/CTN
PSP7	75mm Ceiling Cap	10/60
PSP10	100mm Ceiling Cap	10/40

## End Cover

Provides secure duct closure



PART NO.	DESCRIPTION	QTY/CTN
PSE7	75mm End Cover	10/60
PSE10	100mm End Cover	10/40

## Joiner

Perfect for joining duct lengths



PART NO.	DESCRIPTION	QTY/CTN
PSJ7	75mm Joiner	10/60
PSJ10	100mm Joiner	10/40



## Wall Plate

Designed to cover wall penetrations.



PART NO.	DESCRIPTION	QTY/CTN
PSCA7	75mm Wall Plate	10
PSCA10	100mm Wall Plate	10

## Tee Joint

Perfect for combining duct installation.



PART NO.	DESCRIPTION	QTY/CTN
PST107	75mm / 100mm Tee Joint (Reducers included)	5

## Flexible Joint

Enables easy installation of duct with obstacles (e.g. gutters)



PART NO.	DESCRIPTION	QTY/CTN
PSF75	75mm x 500mm Flexible Joint	20
PSF710	75mm x 1000mm Flexible Joint	20
PSF108	100mm x 800mm Flexible Joint	20

## Reducer

Used when joining 100mm and 75mm duct.



PART NO.	DESCRIPTION	QTY/CTN
PSDR107	100mm - 75mm Reducer	10

# PR PIPE

## PACIFIC DUCT

Designed for covering insulated copper pipes, drain and electrical on an air conditioning installation.

Available in 2 popular sizes (75mm & 100mm) Pacific Duct has been manufactured to be strong and easy to install saving time on your job site.

Manufactured from rigid PVC, Pacific Duct is UV stabilized and can be easily painted to blend with surroundings.

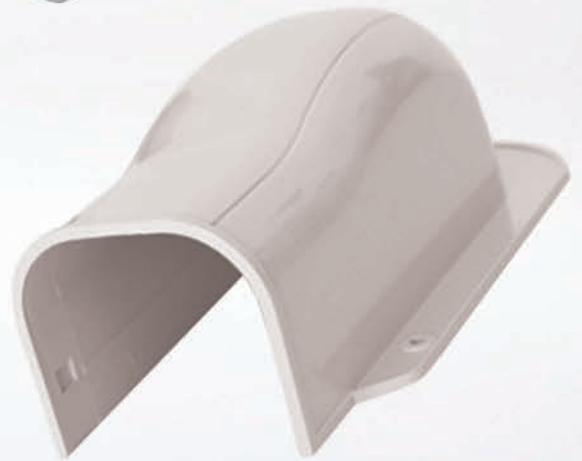



# DRAIN PIPE & FITTINGS

- 55** Drain Pipe & Fittings
- 60** Condensate Traps
- 62** Flexible Drain Pipe
- 63** Clear Vinyl PVC Tubing
- 64** Xtra Accessories





# Drain Pipe & Fittings

Pro Pipe uPVC Drain Pipe and Fittings are manufactured to the highest quality and marked specifically for Refrigeration and Air Conditioning use.

## Air Conditioning & Refrigeration Drain Pipe

PART NO.	DESCRIPTION	QTY/PK
15XCE	15mm AC&R Pipe (3.9m Length)	10
20XCE	20mm AC&R Pipe (3.9m Length)	10
25XCE	25mm AC&R Pipe (3.9m Length)	10
32XCE	32mm AC&R Pipe (3.9m Length)	10

PART NO.	DESCRIPTION	QTY/BULK
15XDP21P	15mm AC&R Pipe (2.1m Length) (10pk)	1/100
20XDP21P	20mm AC&R Pipe (2.1m Length) (10pk)	1/70





## 90° Equal Elbow

PART NO.	DESCRIPTION	QTY/PK
2103015CP	15mm Equal Elbow 90°	50
2103020CP	20mm Equal Elbow 90°	50
2103025CP	25mm Equal Elbow 90°	50
2103032CP	32mm Equal Elbow 90°	10



## 45° Equal Elbow

PART NO.	DESCRIPTION	QTY/PK
2117015CP	15mm Equal Elbow 45°	50
2117020CP	20mm Equal Elbow 45°	50
2117025CP	25mm Equal Elbow 45°	50
2117032CP	32mm Equal Elbow 45°	10



## Equal Tee

PART NO.	DESCRIPTION	QTY/PK
2106015CP	15mm Equal Tee	50
2106020CP	20mm Equal Tee	50
2106025CP	25mm Equal Tee	50
2106032CP	32mm Equal Tee	10



## Double End Socket

PART NO.	DESCRIPTION	QTY/PK
2108015CP	15mm Double End Socket	50
2108020CP	20mm Double End Socket	50
2108025CP	25mm Double End Socket	50
2108032CP	32mm Double End Socket	10





## Barrel Union

Provides a simple way to inspect your drain for blockages. The threaded union is easy to pull apart and reinstall.



PART NO.	DESCRIPTION	QTY/PK
2122015	15mm Barrel Union	1
2122020	20mm Barrel Union	1
2122025	25mm Barrel Union	1
2122032	32mm Barrel Union	1

## Reducing Socket

Used to go directly from one size pipe to another.



PART NO.	DESCRIPTION	QTY/PK
2109020015	20mm x 15mm Reducing Socket	50
2109025015	25mm x 15mm Reducing Socket	50
2109025020	25mm x 20mm Reducing Socket	50
2109032025	32mm x 25mm Reducing Socket	10

## Reducing Bush

Used to go from one size fitting to a smaller pipe. i.e. 20 to 15mm reducing bush - one end slots into a 20mm fitting, 15mm pipe slots into the other end.



PART NO.	DESCRIPTION	QTY/PK
2110020015	20mm x 15mm Reducing Bush	50
2110025015	25mm x 15mm Reducing Bush	50
2110025020	25mm x 20mm Reducing Bush	50

## End Cap

PART NO.	DESCRIPTION	QTY/PK
2113015	15mm End Cap	10
2113020	20mm End Cap	10
2113025	25mm End Cap	5
2113032	32mm End Cap	1





## Drain Pan Fitting

Easy to install purpose designed drain pan adaptor with threaded waterproof seal that can be easily connected to either 15mm or 20mm rigid U-pvc pipe.



PART NO.	DESCRIPTION	QTY/PK
2114015NS	15mm Drain Pan Adaptor	1
2114020NS	20mm Drain Pan Fitting	1

## Threaded Female Socket

PART NO.	DESCRIPTION	QTY/PK
2111015	15mm Female Faucet Socket	50
2111020	20mm Female Faucet Socket	50
2111025	25mm Female Faucet Socket	50



## Male Valve Socket

PART NO.	DESCRIPTION	QTY/PK
2112015	15mm Male Valve Socket	50
2112020	20mm Male Valve Socket	50
2112025	25mm Male Valve Socket	50



## Surface Mounts

PART NO.	DESCRIPTION
B7616	15mm Drain Surface Mount (10pk)
B7615	20mm Drain Surface Mount (10pk)
B7614	25mm Drain Surface Mount (10pk)





## White Pipe Saddle (Full)

Zinc Allum full saddles finished in white powder coat to suit Pro Pipe AC&R Drain pipe.

PART NO.	DESCRIPTION	QTY/PK
PPS084	15mm Pipe Saddle	100
PPS106	20mm Pipe Saddle	100
PPS143	25mm Pipe Saddle	100
PPS168	32mm Pipe Saddle	20
PS175	40mm Stand-Off Saddle	20



## Zinc Plated Pipe Saddle (Half)

PART NO.	DESCRIPTION	QTY/PK
ZPC075	15mm Single Side H/Duty Clip	100
ZPC100	20mm Single Side H/Duty Clip	100
CON032	25mm Single Side H/Duty Clip	20
CON040	40mm Single Side H/Duty Clip	10
CON050	50mm Single Side H/Duty Clip	10



## Stand Off Bracket (White)

2 piece steel bracket finished in white powder coat to suit the range of AC&R drain pipe.

PART NO.	DESCRIPTION	QTY/PK
PPSB075	15mm Stand Off Bracket	10
PPSB100	20mm Stand Off Bracket	10
PPSB125	25mm Stand Off Bracket	10
PPSB168	32mm Stand Off Bracket	1



## Rod Hangers

Suits 10mm threaded rod.

PART NO.	DESCRIPTION	QTY/PK
PPSRH15	15mm Rod Hanger	10
PPSRH20	20mm Rod Hanger	10
PPSRH25	25mm Rod Hanger	10





# Condensate Traps

We have a wide range of traps for AC installs, from the best selling TPP113 condensate trap to waterless traps that can be installed on both positive/negative pressure systems and don't require condensate to form the trap.

## Des Champs Waterless Trap - Negative Pressure

- Waterless trap works all year round
- Unclips for easy maintenance
- Compact design for tight areas



PART NO.	DESCRIPTION
FCN051	20mm Waterless Trap (Negative Pressure)

## Des Champs Waterless Trap - Positive/Negative Pressure

Waterless trap works all year without needing condensate.

PART NO.	DESCRIPTION
RLC051C	20mm Waterless Trap - Pos/Neg Pressure





## Pro Pipe 20mm J-Trap Kit

Forms a trap by holding condensate, improving efficiency and stopping bad odours.

PART NO.	DESCRIPTION
TPP113	20mm Clear J Trap Kit



## Pro Pipe J-Trap

A simple clear condensate trap which holds water to stop air flow. Joins to drain pipe with 90° elbow to form a trap.

PART NO.	DESCRIPTION
JTRAP	20mm Clear J Trap



## Pigtail Traps

A simple solid PVC condensate trap which holds water to stop air flow. Joins to drain pipe with double end sockets to form a trap.

PART NO.	DESCRIPTION
PIG15	15mm Pigtail Trap
PIG20	20mm Pigtail Trap



## Bluecap

Designed to slip onto 20mm Drain Pipe Fittings, allows access for cleaning.

PART NO.	DESCRIPTION
TCAP113	20mm Bluecap



## Flexible Brush

Used to clean our 20mm Condensate Traps.

PART NO.	DESCRIPTION
TPPBR	Flexible Brush





# Flexible Drain Pipe

## Flexible Drain Pipe

For standard mini split installations, use flexible condensate drain pipe.

PART NO.	DESCRIPTION	QTY/BULK
<b>FDP16</b>	16mm Corrugated Roll - 50m	1/45
<b>FDPI19</b>	19mm Corrugated Insulated Roll - 20m	1/30
<b>FDPS16</b>	16mm Smooth Bore Roll - 30m	1/28

\*Flexible drain pipe not to be put into situations where it cannot be accessed or removed for cleaning. i.e. Stud or cavity walls







## Braided PVC Tubing

PART NO.	DESCRIPTION
AX5100	6mm Braided Vinyl Tubing - 30m Roll
AX5101	10mm Braided Vinyl Tubing - 30m Roll



## Clear PVC Tubing

Clear PVC tubing, non toxic. Manufactured to Australian Standards. Ideal for refrigeration and air conditioning condensate drain and condensate pump connections.

**Temperature range:** -10°C to +60°C

PART NO.	DESCRIPTION
PVC3MM	3mm Clear Vinyl Tubing - 30m Roll
PVC4MM	4mm Clear Vinyl Tubing - 30m Roll
PVC6MM	6mm Clear Vinyl Tubing - 30m Roll
PVC8MM	8mm Clear Vinyl Tubing - 30m Roll
PVC10MM	10mm Clear Vinyl Tubing - 30m Roll
PVC12MM	12mm Clear Vinyl Tubing - 30m Roll
PVC16MM	16mm Clear Vinyl Tubing - 30m Roll
PVC19MM	19mm Clear Vinyl Tubing - 30m Roll
PVC25MM	25mm Clear Vinyl Tubing - 30m Roll



PART NO.	DESCRIPTION
PVC6MM/1	6mm Clear Vinyl Tubing - 100m Roll
PVC8MM/1	8mm Clear Vinyl Tubing - 100m Roll
PVC10MM/1	10mm Clear Vinyl Tubing - 100m Roll

## Clear PVC Tubing - Packs

PART NO.	DESCRIPTION
FP3006	6mm Clear Vinyl Tubing x 3m
FP3010	10mm Clear Vinyl Tubing x 3m





# Xtra Accessories

## Self Sealing Pipe Connector

PART NO.	DESCRIPTION
FP2038	6/10mm Self Sealing Pipe Connector (13mm) 3pk



## Pump to PVC Drain Pipe Adaptor

PART NO.	DESCRIPTION
CPK6	Condensate Adapter CVT to 15mm Ridgid PVC
CPK10	Condensate Adapter CVT to 20mm Ridgid PVC





## Clear PVC Connectors - 5 Pack

PART NO.	DESCRIPTION
FP2622	6mm Straight Connector
FP2028	6mm Elbow Connector
FP2024	6mm Tee Connector
FP2624	10mm Straight Connector
FP2032	10mm Elbow Connector
FP2030	10mm Tee Connector
FP2020	10mm - 6mm Reducing Connector



## 90° Long Arm Bend - 3 pack

PART NO.	DESCRIPTION
FP2006	Split A/C Outlet to Mini Pump - 12 to 16mm



## Ducted A/C to 15mm Pipe Adaptors - 3 pack

PART NO.	DESCRIPTION
FP2011	16mm Pipe Rubber Adaptor to 15mm PVC Drain
FP2012	26mm Pipe Rubber Adaptor to 15mm PVC Drain
FP2013	32mm Pipe Rubber Adaptor to 15mm PVC Drain



## Ducted A/C to 20mm Pipe Adaptors - 3 pack

PART NO.	DESCRIPTION
FP2042	16mm Pipe Rubber Adaptor to 20mm PVC Drain
FP2044	26mm Pipe Rubber Adaptor to 20mm PVC Drain
FP2046	32mm Pipe Rubber Adaptor to 20mm PVC Drain





## Pipe to Waste Adaptors - 3 pack

PART NO.	DESCRIPTION
FP2017	15mm PVC Drain to 32mm Waste Pipe
FP2018	15mm PVC Drain to 40mm Waste Pipe



## Stainless Steel Hose Clamps - 5 pack

PART NO.	DESCRIPTION
FP2050	10 - 16mm Stainless Steel Hose Clamp
FP2052	16 - 25mm Stainless Steel Hose Clamp
FP2054	23 - 32mm Stainless Steel Hose Clamp



## Drain Pipe Stickers

PART NO.	DESCRIPTION
CDPLABEL	HVAC/R Condensate Drain Pipe Stickers (333 per roll)

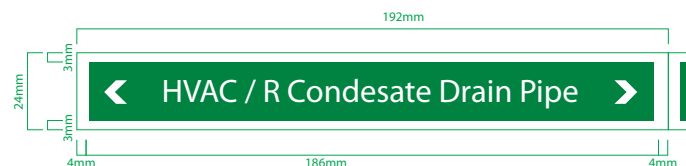

## Non Return Valves - 5 pack

PART NO.	DESCRIPTION
FP2628	6mm Non Return Valve
FP2630	10mm Non Return Valve





# CONDENSER GUARDS

## **MAXIMUM STRENGTH**

Made of Heavy Duty Angle Iron & 25mm steel mesh and hot dipped galvanised to last.

## **MAXIMUM SECURITY**

Can be bolted to a wall or fastened to a concrete pad. The front access panel can be padlocked for maximum security.

## **MAXIMUM STANDARDS**

PROTECT Guards comply to Government Specifications.





# PIPE SUPPORTS, CHANNEL & ACCESSORIES

- 69** Pipe Supports
- 81** Channel & Xtra Accessories



# Pipe Supports

Designed to make installations easier, this professional range includes everything from channel clips, rod clips and surface mount clips, all designed to offer secure support to pipework on AC and refrigeration systems.





# TUFFSLAB

## ECO+

The **MOST** sustainable and environmentally considered HVAC equipment slab available in the market.

The revolutionary TuffSlab Eco+ contributes to a circular economy by purely using industrial waste plastic to create the product.

Not only does this make TuffSlab Eco+ the **most sustainable product** in the market, but also the **best value for money**.

### KEY FEATURES



Added Fastening Points



Made from 100% recycled industrial waste plastic



Sloped water run off channels for better drainage



Ventilation Points



160kg Load Rating



**Product Name:** TuffSlab Eco+

**Part Number:** TSLAB-MB (Black)

**Size:** 900mm L x 430mm W x 50mm H

**Also Available:** TSLAB-MG (Grey)

**For more information, visit [aspenpumps.com.au](https://www.aspenpumps.com.au)**





## Insulclamp

Channel clip ideal for bigger commercial air conditioning and refrigeration installations.

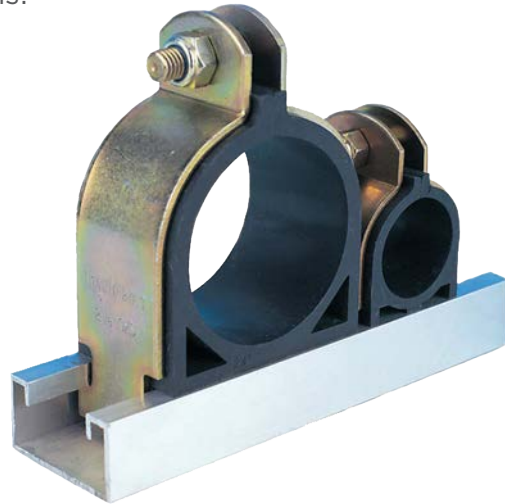

### Key features

- Easy installation into 40x40mm and 40x20mm channel
- Insulates against heat loss and reduces vibration
- Quick to install with lock nuts
- Supports individual pipes into a thermo-rubber cushion between two metal plates
- Thermo-rubber cushion insert withstands maximum temperature of 130°C (zinc bracket 1000°C)



### SIZING OPTIONS

PART NO.	SIZE	HEIGHT ABOVE CHANNEL (mm)	QTY/PK
B6268	1/4"	32	10
B6274	3/8"	35	10
B6267	1/2"	38	10
B6276	5/8"	41	10
B6273	3/4"	44	10
B6277	7/8"	47	10
B6264	1 1/8"	54	10
B6265	1 3/8"	60	10
B6266	1 5/8"	76	10
B6269	2 1/8"	92	5
B6270	2 5/8"	98	5
B6271	3 1/8"	117	5
B6272	3 5/8"	130	5
B6275	4 1/8"	143	5

### SPECIFICATIONS

Materials of construction	Zinc passivated steel with rubber cushion
Max. temp	130°C
Max. rec. distance per clip	1.2m

### Installation instructions

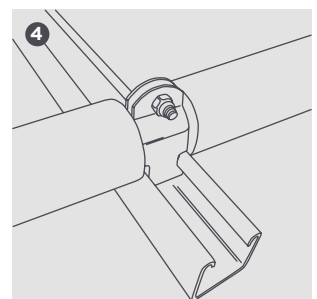
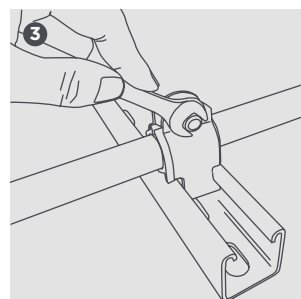
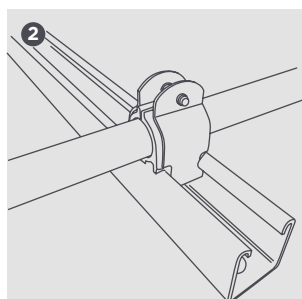
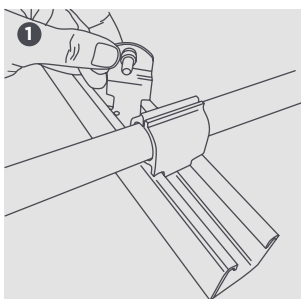



## Channel Clip



		SIZING OPTIONS			
Part No.	Size	Lagging			
		6mm	9mm	13mm	19mm
B6842	6mm (1/4")				
B6844	9mm (3/8")				
B6843	13mm (1/2")				
B6845	16mm (5/8")				
B6846	19mm (3/4")	1/4"			
B6847	22mm (7/8")	3/8"			
B6848	25mm (1")	1/2"	1/4"		
B6849	28mm (1 1/8")	5/8"	3/8"		
B6850	32mm (1 1/4")	3/4" 7/8"	1/2" 5/8"	1/4"	
B6851	35mm (1 3/8")		3/4"	3/8" 1/2"	
B6852	38mm (1 1/2")	1 1/8"	7/8"	5/8"	
B6853	41mm (1 5/8")	1 3/8"	1 1/8"	3/4" 7/8"	1/4" 3/8"
B6854	50mm (2")				1/2"
B6855	55mm (2 1/8")	1 5/8"	1 3/8" 1 5/8"	1 1/8" 1 3/8"	5/8" 3/4" 7/8"

## Stud Clip



		SIZING OPTIONS			
Part No.	Size	Lagging			
		6mm	9mm	13mm	19mm
B6814	6mm (1/4")				
B6816	9mm (3/8")				
B6815	13mm (1/2")				
B6817	16mm (5/8")				
B6818	19mm (3/4")	1/4"			
B6819	22mm (7/8")	3/8"			
B6820	25mm (1")	1/2"	1/4"		
B6821	28mm (1 1/8")	5/8"	3/8"		
B6822	32mm (1 1/4")	3/4" 7/8"	1/2" 5/8"		
B6823	35mm (1 3/8")		3/4"	3/8" 1/2"	
B6824	38mm (1 1/2")	1 1/8"	7/8"	5/8"	
B6825	41mm (1 5/8")	1 3/8"	1 1/8"	3/4" 7/8"	1/4" 3/8"
B6826	50mm (2")				1/2"
B6827	55mm (2 1/8")	1 5/8"	1 3/8" 1 5/8"	1 1/8" 1 3/8"	5/8" 3/4" 7/8"



## Channel Clip

Unique ratchet design ensures quick installation with good hold both vertically and horizontally.

 Channel

 Rod

 Surface



### Key features

- Easy installation into 40x40mm and 40x20mm channel
- Unique lockable ratchet design
- Quick to fit over insulated pipes
- Safety lock ensure that the correct pressure is applied to hold both pipe and insulation



## Channel Clip

Pipe size pipe required		PIPE WITH INSULATION		
		9mm	13mm	19mm
		CLIP SIZE REQUIRED		
1/4"	1/4"	1"	1 1/4"	1 5/8"
3/8"	3/8"	1 1/8"	1 3/8"	1 5/8"
1/2"	1/2"	1 1/4"	1 3/8"	2"
5/8"	5/8"	1 1/4"	1 1/2"	2 1/8"
3/4"	3/4"	1 3/8"	1 5/8"	2 1/8"
7/8"	7/8"	1 1/2"	1 5/8"	2 1/8"
1"	1"	1 5/8"	2"	
1 1/8"	1 1/8"	1 5/8"	2 1/8"	
1 1/4"	1 1/4"	2"	2 1/8"	
1 3/8"	1 3/8"	2 1/8"	2 1/8"	
1 1/2"	1 1/2"	2 1/8"		
1 5/8"	1 5/8"	2 1/8"		
2"	2"			
2 1/8"	2 1/8"			

SPECIFICATIONS	
Materials of construction	Nylon
Max. temp	+70°C
Max. rec. distance per clip	1.2m

## PVC Drain Pipe Selection Guide Channel Clip

Pipe size pipe required		PIPE WITH INSULATION		
		9mm	13mm	19mm
		CLIP SIZE REQUIRED		
15mm	7/8"	1 1/2"	1 5/8"	2 1/8"
20mm	1"	1 5/8"	2"	
25mm	1 3/8"	2"	2 1/8"	

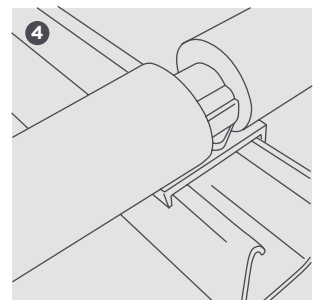
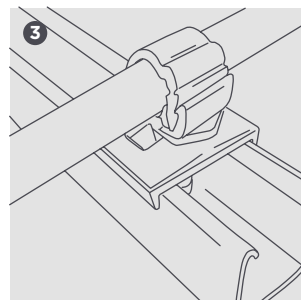
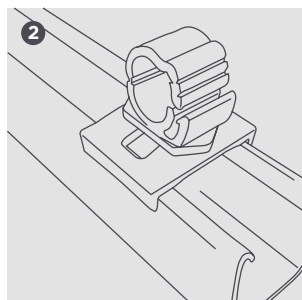
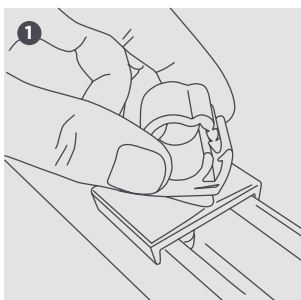

### Installation instructions





## Stud Clip

Unique ratchet design ensures quick installation and adjustment.

-  Channel
-  Rod
-  Surface



### Key features

- Suits M10 threaded rod
- Fast fixing direct to studding
- Simple to install, adjust and relocate



## Stud Clip

Pipe size pipe required		PIPE WITH INSULATION		
		9mm	13mm	19mm
		CLIP SIZE REQUIRED		
1/4"	1/4"	1"	1 1/4"	1 5/8"
3/8"	3/8"	1 1/8"	1 3/8"	1 5/8"
1/2"	1/2"	1 1/4"	1 3/8"	2"
5/8"	5/8"	1 1/4"	1 1/2"	2 1/8"
3/4"	3/4"	1 3/8"	1 5/8"	2 1/8"
7/8"	7/8"	1 1/2"	1 5/8"	2 1/8"
1"	1"	1 5/8"	2"	
1 1/8"	1 1/8"	1 5/8"	2 1/8"	
1 1/4"	1 1/4"	2"	2 1/8"	
1 3/8"	1 3/8"	2 1/8"	2 1/8"	
1 1/2"	1 1/2"	2 1/8"		
1 5/8"	1 5/8"	2 1/8"		
2"	2"			
2 1/8"	2 1/8"			

### SPECIFICATIONS

Materials of construction	Nylon
Max. temp	70°C
Max. rec. distance per clip	1.2m

## PVC Drain Pipe Selection Guide Stud Clip

Pipe size pipe required		PIPE WITH INSULATION		
		9mm	13mm	19mm
		CLIP SIZE REQUIRED		
15mm	7/8"	1 1/2"	1 5/8"	2 1/8"
20mm	1"	1 5/8"	2"	
25mm	1 3/8"	2"	2 1/8"	

### Installation instructions

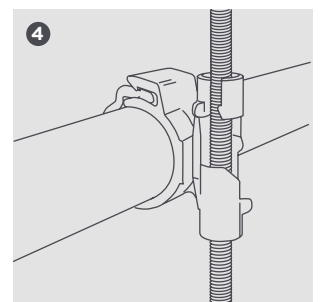
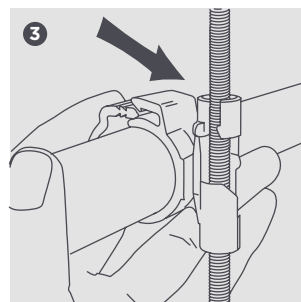
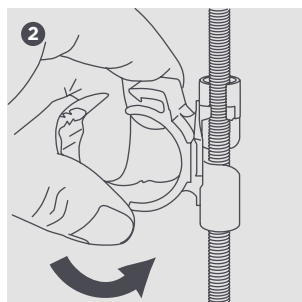
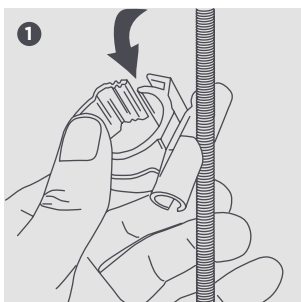



## Metal Hanger

A rod clip ideal for supporting air conditioning line set pairs.

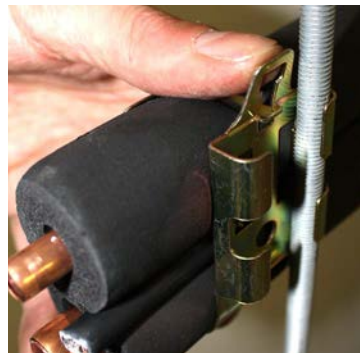

### Key features

- Fits on both M8 and M10 studding
- Rapid 2 pipe installation
- Avoids the need for cable trays
- Zinc passivated to resist corrosion

SIZING OPTIONS				
PART NO.	DESCRIPTION	LIQUID*	GAS*	QTY/PK
B6492	2	3/8"	5/8"	10
B6493	3	1/2"	7/8"	10
B6494	4	5/8"	1 1/8"	10

SPECIFICATIONS	
Materials of construction	Zinc passivated mild steel
Max. temp	1000°C
Max. rec. distance per clip	1.2m

\*Approximate pipe sizes (allowing for insulation)

### Installation instructions

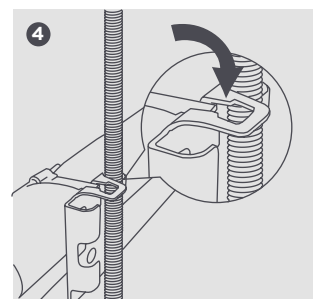
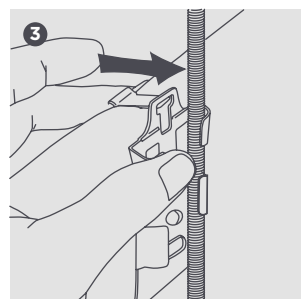
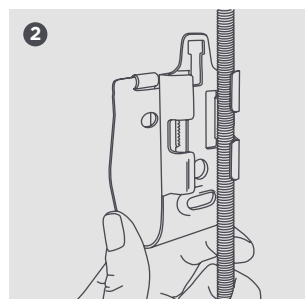
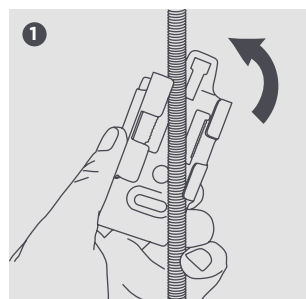



## Plastic Hanger

This dual stud size clamping system will fit securely to M10 studding.



### Key features

- Easy installation
- Fits on M10 studding
- Avoids the need for cable tray
- Adjustable clipping mechanism

SIZING OPTIONS				
PART NO.	DESCRIPTION	LIQUID*	GAS*	QTY/PK
B6543	P2	3/8"	5/8"	5
B6544	P3	1/2"	7/8"	5
B6545	P4	5/8"	1 1/8"	5

SPECIFICATIONS	
Materials of construction	Nylon
Max. temp	70°C
Max. rec. distance per clip	1.2m

\*Approximate pipe sizes (allowing for insulation)

### Installation instructions

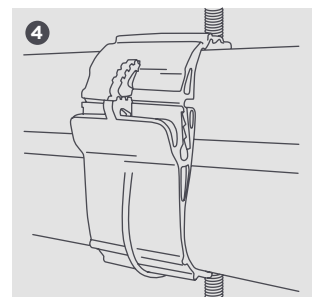
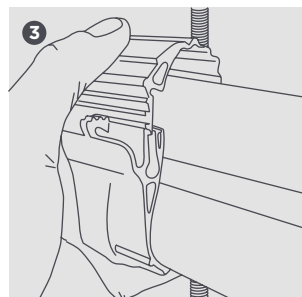
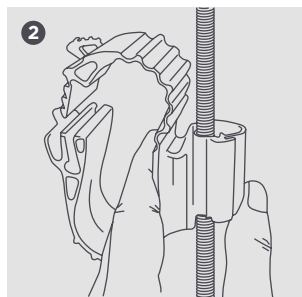
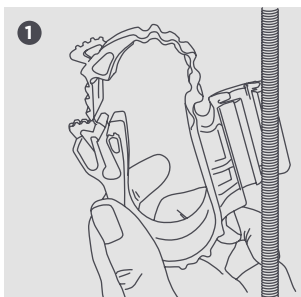



## Pinch Clip

The Xtra Pinch Clip rod clip is ideal for air conditioning line set pairs.



Channel



Rod



Surface



### Key features

- Pinch Clip locates quickly to M8 and M10 studding
- Robust metal construction
- Snap shut lid secures pipe set
- Quick and easy pipe installation
- Wide metal construction for greater pipe support
- Can also be used for surface mount
- Ideal for when you need to meet fire regulations

SIZING OPTIONS				
PART NO.	DESCRIPTION	LIQUID*	GAS*	QTY/PK
B6561	2	3/8"	5/8"	10
B6562	3	1/2"	7/8"	10
B6563	4	5/8"	1 1/8"	10

SPECIFICATIONS	
Materials of construction	Powder coated mild steel
Max. temp	1000°C
Max. rec. distance per clip	1.2m

\*Approximate pipe sizes (allowing for insulation)

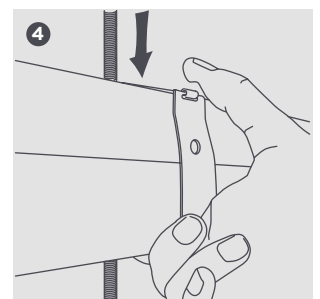
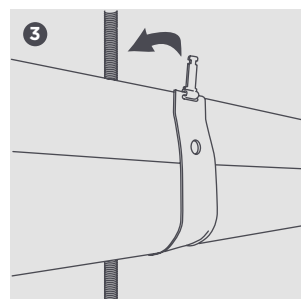
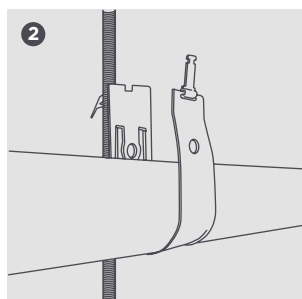
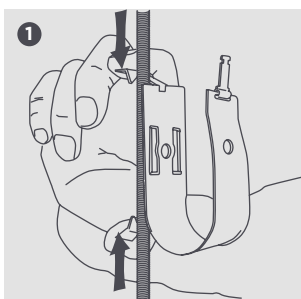

### Installation instructions





### 3 Pipe Clip

The uniquely designed Xtra 3 Pipe Clip provides support for VRV/VRF systems pipework.

-  Channel
-  Rod
-  Surface



#### Key features

- Available for a wide range of pipe group sizes
- Locates to M8 and M10 studding
- Wide metal arms for greater pipe support
- No need for cable tray
- Hinge security cover plate fastens with one screw
- Can also be used for surface mount

SIZING OPTIONS				
PART NO.	DESCRIPTION	PIPE GROUPS FROM	PIPE GROUPS TO	QTY/PK
B6361	1	3/8" 5/8" 3/4"	1/2" 3/4" 1"	5
B6362	2	1/2" 1 1/8" 3/4"	5/8" 1" 1 1/8"	5
B6363	3	5/8" 1 1/8" 1 1/8"	3/4" 1 3/8" 1 1/8"	5
B6364	4	7/8" 1 3/8" 1 1/8"	3/4" 1 5/8" 1 3/8"	5

SPECIFICATIONS	
Materials of construction	Powder coated mild steel
Max. temp	1000°C
Max. rec. distance per clip	1.2m

\*Approximate pipe sizes (allowing for 13mm insulation)

#### Installation instructions

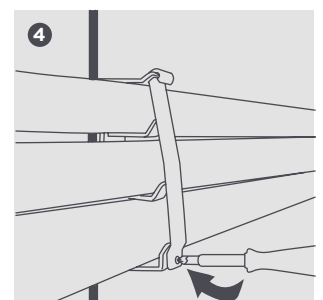
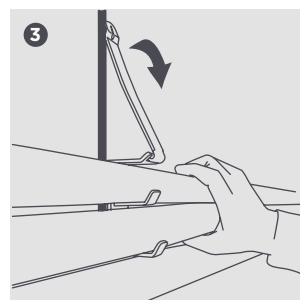
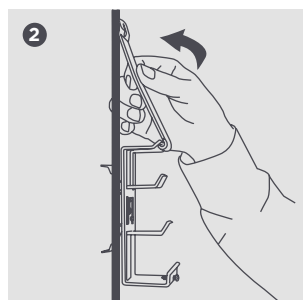
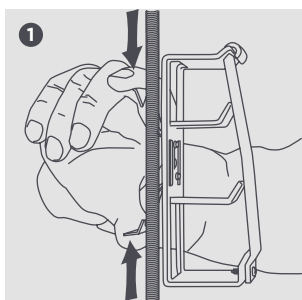





## Grip Lock

Best selling versatile clip mounts to any surface. Ideal for air conditioning line sets.



Channel



Rod



Surface

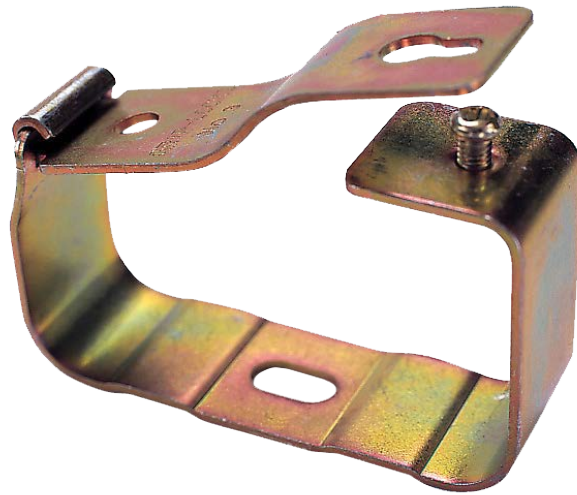

### Key features

- Fits directly to a wall or solid ceiling
- Hinged for rapid pipe installation
- Space for electrical cables and condensate hose
- Zinc and colour passivated to resist corrosion
- Wide metal components for good pipe support

SIZING OPTIONS						
PART NO.	DESCRIPTION	LIQUID*	GAS*	WIDTH (mm)	HEIGHT (mm)	QTY/ PK
B6186	Size 1	1/4"	1/2"	54	30	10
B6187	Size 2	3/8"	5/8"	60	32	10
B6188	Size 3	1/2"	7/8"	67	37	10
B6189	Size 4	5/8"	1 1/8"	80	46	10

SPECIFICATIONS	
Materials of construction	Zinc passivated mild steel
Max. temp	1000°C
Max. rec. distance per clip	1.2m

\*Approximate pipe sizes (allowing for 10mm insulation)

### Installation instructions

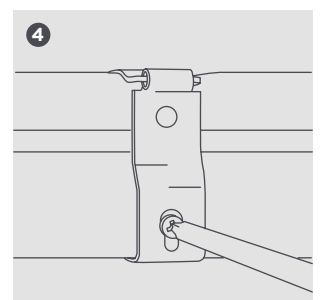
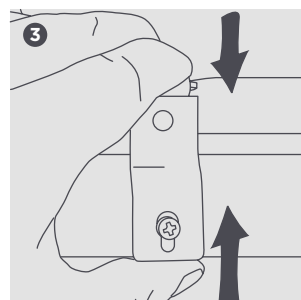
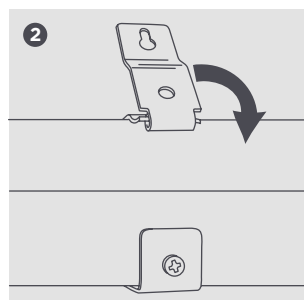
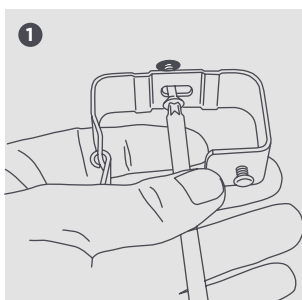



## Pipe Tie

Easy to fix and great for multiple pipework routes.

 Channel

 Rod

 Surface



### Key features

- Quick fixing, lightweight and reusable
- Perfect for multiple pipework routes
- Wide tie width to protect pipe insulation
- Withstands maximum temperature of 70°C

#### SIZING OPTIONS

PART NO.	DESCRIPTION	DIMENSIONS	QTY/PK
B6551	T250 Black	250 x 20mm	10
B6552	T300 Black	300 x 20mm	10
B6553	T350 Black	350 x 20mm	10
B6554	T400 Black	400 x 20mm	10

#### SPECIFICATIONS

Materials of construction	LDPE
Max. temp	70°C
Max. rec. distance per clip	1.2m

### Installation instructions

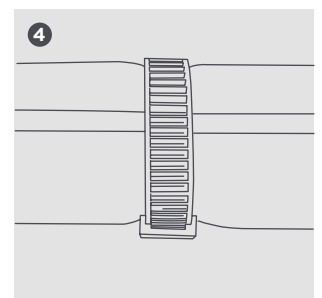
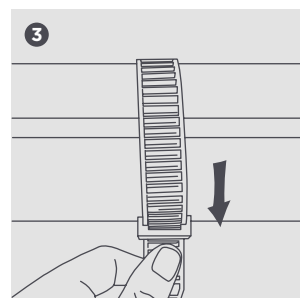
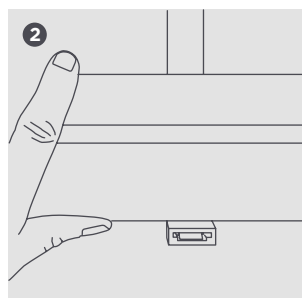
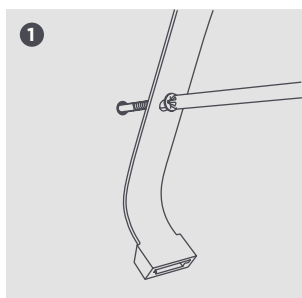



# Channel & Accessories

## Slotted Channel

Slotted Channel is made from strip steel and comes in either Hot Dip Galvanized or Galvabond.

Manufactured to the following Australian Standards.  
HDG - AS/NZ1365, AS1594  
GB - AS1397



PART NO.	SIZE
PE1000SH2	41 x 41 x 2.5mm HDG Slotted Channel - 2m
PE2000SG2	41 x 41 x 1.6mm GB Slotted Channel - 2m
PE3300SH2	41 x 21 x 2.5mm HDG Slotted Channel - 2m
PE4000SG2	41 x 21 x 1.6mm GB Slotted Channel - 2m

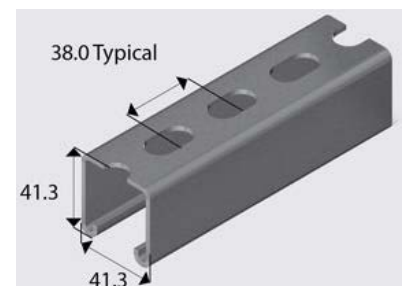



## Strut Clamps

Two piece zinc plated pipe clamp for 40mm + 20mm channel supplied with slotted hex head screws available also in stainless steel and HDG. Supplied in packs of 5.

PART NO.	DESCRIPTION	PART NO.	DESCRIPTION
E511Z	11mm P-Clamp	E592Z	92mm P-Clamp
E514Z	14mm P-Clamp	E595Z	95mm P-Clamp
E517Z	17mm P-Clamp	E598Z	98mm P-Clamp
E519Z	19mm P-Clamp	E5102Z	102mm P-Clamp
E521Z	21mm P-Clamp	E5105Z	105mm P-Clamp
E525Z	25mm P-Clamp	E5108Z	108mm P-Clamp
E527Z	27mm P-Clamp	E5111Z	111mm P-Clamp
E529Z	29mm P-Clamp	E5114Z	114mm P-Clamp
E532Z	32mm P-Clamp	E5117Z	117mm P-Clamp
E534Z	34mm P-Clamp	E5121Z	121mm P-Clamp
E538Z	38mm P-Clamp	E5127Z	127mm P-Clamp
E543Z	43mm P-Clamp	E5133Z	133mm P-Clamp
E548Z	48mm P-Clamp	E5140Z	140mm P-Clamp
E551Z	51mm P-Clamp	E5146Z	146mm P-Clamp
E554Z	54mm P-Clamp	E5152Z	152mm P-Clamp
E557Z	57mm P-Clamp	E5160Z	160mm P-Clamp
E560Z	60mm P-Clamp	E5165Z	165mm P-Clamp
E564Z	64mm P-Clamp	E5171Z	171mm P-Clamp
E567Z	67mm P-Clamp	E5178Z	178mm P-Clamp
E570Z	70mm P-Clamp	E5191Z	191mm P-Clamp
E573Z	73mm P-Clamp	E5203Z	203mm P-Clamp
E576Z	76mm P-Clamp	E5216Z	216mm P-Clamp
E579Z	79mm P-Clamp	E5227Z	227mm P-Clamp
E583Z	83mm P-Clamp	E5230Z	230mm P-Clamp
E586Z	86mm P-Clamp	E5241Z	241mm P-Clamp
E589Z	89mm P-Clamp	E5254Z	254mm P-Clamp



## Selection Guides

### Strut Clamp PVC Pipe

Pipe size pipe required	PIPE WITH INSULATION			
	9mm	13mm	19mm	
<b>CLIP SIZE REQUIRED</b>				
15mm	21	38	48	60
20mm	27	43	51	64
25mm	34	51	60	73

### Strut Clamp Copper Pipe

Pipe size pipe required	PIPE WITH INSULATION			
	9mm	13mm	19mm	
<b>CLIP SIZE REQUIRED</b>				
1/4"	25	32	43	
3/8"	11	27	38	48
1/2"	14	29	38	51
5/8"	17	34	43	54
3/4"	19	38	43	57
7/8"	21	38	48	60
1"	25	43	51	64
1 1/8"	29	48	54	67
1 1/4"	32	51	57	70
1 3/8"	34	54	60	73
1 1/2"	38	57	64	76
1 5/8"	43	60	67	79
2"	51	67	76	89
2 1/8"	54	73	79	92
2 5/8"	67	86	92	105



## Insulated Pipe Blocks

PART NO.	DESCRIPTION	STRUT CLAMP TO SUIT
IPB13006	Pipe Block 13mm Wall x 6mm ID	34mm
IPB13010	Pipe Block 13mm Wall x 10mm ID	38mm
IPB13013	Pipe Block 13mm Wall x 13mm ID	38mm
IPB13016	Pipe Block 13mm Wall x 16mm ID	43mm
IPB13019	Pipe Block 13mm Wall x 19mm ID	43mm
IPB13022	Pipe Block 13mm Wall x 22mm ID	48mm
IPB13025	Pipe Block 13mm Wall x 25mm ID	51mm
IPB13028	Pipe Block 13mm Wall x 28mm ID	54mm
IPB13035	Pipe Block 13mm Wall x 35mm ID	60mm
IPB13042	Pipe Block 13mm Wall x 42mm ID	67mm
IPB13054	Pipe Block 13mm Wall x 54mm ID	79mm
IPB19006	Pipe Block 19mm Wall x 6mm ID	43mm
IPB19010	Pipe Block 19mm Wall x 10mm ID	48mm
IPB19013	Pipe Block 19mm Wall x 13mm ID	51mm
IPB19016	Pipe Block 19mm Wall x 16mm ID	54mm
IPB19019	Pipe Block 19mm Wall x 19mm ID	57mm
IPB19022	Pipe Block 19mm Wall x 22mm ID	60mm
IPB19025	Pipe Block 19mm Wall x 25mm ID	64mm
IPB19028	Pipe Block 19mm Wall x 28mm ID	67mm
IPB19035	Pipe Block 19mm Wall x 35mm ID	73mm
IPB19042	Pipe Block 19mm Wall x 42mm ID	79mm
IPB19054	Pipe Block 19mm Wall x 54mm ID	92mm
IPB19067	Pipe Block 19mm Wall x 67mm ID	102mm
IPB25006	Pipe Block 25mm Wall x 6mm ID	57mm
IPB25010	Pipe Block 25mm Wall x 10mm ID	60mm
IPB25013	Pipe Block 25mm Wall x 13mm ID	64mm
IPB25016	Pipe Block 25mm Wall x 16mm ID	67mm
IPB25019	Pipe Block 25mm Wall x 19mm ID	70mm
IPB25022	Pipe Block 25mm Wall x 22mm ID	73mm
IPB25025	Pipe Block 25mm Wall x 25mm ID	76mm
IPB25028	Pipe Block 25mm Wall x 28mm ID	79mm
IPB25035	Pipe Block 25mm Wall x 35mm ID	86mm
IPB25042	Pipe Block 25mm Wall x 42mm ID	92mm
IPB25054	Pipe Block 25mm Wall x 54mm ID	105mm
IPB25067	Pipe Block 25mm Wall x 67mm ID	117mm
IPB32013	Pipe Block 32mm Wall x 13mm ID	76mm
IPB32016	Pipe Block 32mm Wall x 16mm ID	79mm
IPB32019	Pipe Block 32mm Wall x 19mm ID	83mm
IPB32022	Pipe Block 32mm Wall x 22mm ID	86mm
IPB32025	Pipe Block 32mm Wall x 25mm ID	89mm
IPB32028	Pipe Block 32mm Wall x 28mm ID	92mm
IPB32035	Pipe Block 32mm Wall x 35mm ID	95mm
IPB32042	Pipe Block 32mm Wall x 42mm ID	105mm
IPB32054	Pipe Block 32mm Wall x 54mm ID	117mm
IPB32067	Pipe Block 32mm Wall x 67mm ID	127mm





## Black Pipe Sleeves

Designed to protect insulation when securing with a pipe clamp. Fits around the insulation meaning cuts aren't required.



PART NO.	DESCRIPTION
BPS63HTB	63mm Black Pipe Sleeve Support
BPS80HTB	80mm Black Pipe Sleeve Support

## Threaded Rod

- Zinc plated steel threaded rod
- Strength grade 4,6
- ISO metric thread



PART NO.	DESCRIPTION
PTR10Z	M10 Zinc Plated Threaded Rod - 3m

## Accessories

PART NO.	DESCRIPTION
PE1008Z	M10 Channel Spring Nut ZP 4pk
PE1026H	90° Angle Fit 50x50mm EA
PE1325H	90° Angle Fit 90x105mm EA
PE2600	Isolation Strip 20m Roll
PFW10Z	M10 Flat Washer ZP 25pk
PHN10Z	M10 Hex Nuts ZP 25pk
PHS1040Z	M10 Hex Bolt 40mm ZP 4pk
PLD10M	M10 Masonry Drop in Anchor 4pk
PECMP10	Centre Flat Hanger 4pk
PEHMP10	Horizontal Flat Hanger 4pk
PEVMP10	Vertical Flat Hanger 4pk
RC10Z	Rod Coupler M10 ZP 4pk
E1180	End Cap for 40mm Channel

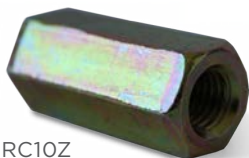

PE1325H



# ANTI VIBRATION

Our high quality range of anti vibration mounts are designed to reduce noise and vibration.

We have a large range to allow for various installations. Fixings come with a rust resistant coating.



Distributed by



**ASPEN  
PUMPS**  
ASIA PACIFIC



# HVACR TOOLS

- 87** Aspen Edge
- 89** Black Diamond
- 93** JB Industries
- 103** Spectroline Leak Detection
- 107** Brazing Torches
- 109** Portable Lifter





TRADE TOOLS



ASPEN  
**EDGE**  
TOOLS

# Aspen Edge

## Aspen Edge R32 Vac Pump



Spark proof design

Gas ballast valve

2 stage direct drive

Ergonomic handle

Solenoid valve

**1440 RPM  
=  
LONG LIFE  
MOTOR**

MODEL	DV-50ER32	DV-100ER32	DV-150ER32
AIR DISPLACEMENT	50L/m	100L/m	150L/m
POWER	190W	360W	560W
OIL CAPACITY	300ml	450ml	590ml



# ASPEN EDGE TOOLS

## A2L Recovery Unit



Ultra lightweight - 8.4kg

Ultra fast liquid recovery

Oil less compressor

PART NO.	DESCRIPTION
RU12A2L	Recovery Unit

## PROCHARGE CS100 Charging Scales



Portable carry case

100kg capacity

Accuracy of +/- 5 grams

PART NO.	DESCRIPTION
CS100	Digital Charging Scales 100kg

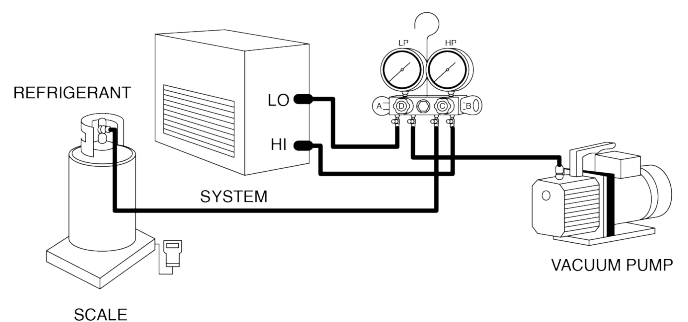



TRADE TOOLS



# Black Diamond

## Manifold Gauge & 5' Hose Sets

PART NO.	DESCRIPTION
BD21355	Manifold & Gauge Set R134/404 + Sight Glass
BD21465	Manifold & Gauge Set R410A/R32



## Manifold Gauge & 5' Hose Sets + Magnet Buckle & Boots

PART NO.	DESCRIPTION
BD27355	Manifold & Gauge Set R134/404 + Sight Glass
BD27455	Manifold & Gauge Set R410A/R32 + Sight Glass





## Flaring Tools

Black Diamond Flaring Tools are made of light weight strong aluminium, the total weight is reduced by more than 40% compared to regular flaring tools.

Quick and easy to use, the titanium finish on the flaring cone makes it last much longer and debris cleans easily from the cone. Comes complete with pipe locator to guarantee consistent flares.



PART NO.	DESCRIPTION
BD14545	1/4" - 3/4" Eccentric Cone Flaring Tool
BD15545	1/4" - 3/4" Eccentric Flaring Tool Drill Drive

## Multi Size Expander Kit

The Black Diamond Expander Kit comes complete with 8 different head sizes including the worlds first 1/4" head saving time over traditional swaging tools.

Both the handle and heads are made of light-weight strong aluminium making it easier to get precise results.

PART NO.	DESCRIPTION
BD13800	1/4" - 1.1/8" Multi Size Expander Kit (8 Heads)
BD13104	1/4" Expander Head
BD13106	3/8" Expander Head
BD13108	1/2" Expander Head
BD13110	5/8" Expander Head
BD13112	3/4" Expander Head
BD13114	7/8" Expander Head
BD13116	1" Expander Head
BD13118	1.1/8" Expander Head
BD13122	1.3/8" Expander Head
BD13126	1.5/8" Expander Head





## Quick Action Tube Benders

Strong aluminium bending former makes it easy to remove bent tubes without damaging.

PART NO.	DESCRIPTION
BD12106	3/8" Quick Action Tube Bender
BD12108	1/2" Quick Action Tube Bender
BD12110	5/8" Quick Action Tube Bender
BD12112	3/4" Quick Action Tube Bender



## Multi Size Tube Bender

Patented 90° indicator lets the user know when they reach 90°. This tube bender set comes with 7 different sizes of Aluminium Bending Forms and is easy to assemble.

PART NO.	DESCRIPTION
BD12999	1/4" - 7/8" Multi Size Tube Bender



## Mini Tube Cutters

**BD11112**  
- Our smallest tube cutter

**BD11166**  
- Great for working conditions where space is limited

PART NO.	DESCRIPTION
BD11112	1/8" - 5/8" Mini Tube Cutter
BD11166	1/8" - 7/8" Small Tube Cutter with Spare Cutter Wheel



## Medium Tube Cutters

**BD11288**  
- Worlds first ever spring loaded tube cutter  
- Good size for most working conditions  
- Easy to grip and smooth to turn  
- Spare cutter wheel included  
- Titanium coated cutter wheels

**BD11382**  
- Slightly larger than the BD11288  
- This model has the same design but will cut up to 1 5/8"  
- Spare cutter wheel included  
- Titanium coated cutter wheels

PART NO.	DESCRIPTION
BD11288	1/8" - 1 1/4" Medium Tube Cutter with Spare Cutter Wheel
BD11382	1/8" - 1 5/8" Medium Tube Cutter with Spare Cutter Wheel





## Large Tube Cutter

- Our flagship cutter, 6 ball bearing rollers and a ball bearing blade
- This tube cutter is also outlined with a double spring design
- This creates an extremely smooth cutting motion and can cut stainless steel pipes up to 3mm in thickness
- Spare cutter wheel included
- Titanium coated cutter wheels

PART NO.	DESCRIPTION
<b>BD11588</b>	3/8" - 2.5/8" Tube Cutter with Spare Cutter Wheel



## Heavy Duty Tube Cutters

- Our flagship cutter, 6 ball bearing rollers and a ball bearing blade
- This tube cutter is also outlined with a double spring design
- This creates an extremely smooth cutting motion and can cut stainless steel pipes up to 3mm in thickness
- Spare cutter wheel included
- Titanium coated cutter wheels

PART NO.	DESCRIPTION
<b>BD11388</b>	1/4" - 1.1/4" H/Duty Tube Cutter with Spare Cutter Wheel



## Spare Cutter Wheels

PART NO.	DESCRIPTION
<b>BD11002</b>	Titanium Cutting Blade to suit BD11166 & BD11288 (2pk)
<b>BD11004</b>	Titanium Cutting Blade to suit BD11388 (2pk)
<b>BD11006</b>	Titanium Cutting Blade to suit BD11382 (2pk)
<b>BD11008</b>	Titanium Cutting Blade to suit BD111588 (2pk)
<b>BD11010</b>	Titanium Cutting Blade to suit BD11112 (2pk)





# JB Industries

JB Industries is the premier manufacturer of American-made HVAC/R products.

For over 50 years, JB has been committed to manufacturing products of the highest quality while providing exceptional customer service. JB products have proudly been made in America since its inception in 1967, with “Made in America” an essential part of the company’s philosophy.

Easy to read backlit display

Low battery indicator

## Digital Vacuum Gauge + Case

The improved DV-24N Digital Vacuum Gauge is an easy-to-use, compact vacuum gauge featuring a sleek new design with enhanced user settings and an extended range sensor.

- Extended range MEMS sensor
- Improved response time for instantaneous vacuum reading
- Allows for direct connection to the A/C unit without a hose
- Audible and visual alarms when target vacuum level is achieved
- Intuitive user menu with custom setting options
- Measures in Microns, PSIA, inHg, Pascals, Torr, mTorr and mBar

PART NO.	DESCRIPTION
DV24N	Digital Vacuum Gauge + Case





Made in USA



## Platinum Series Vacuum Pump

JB Industries' PLATINUM® series vacuum pump is the best pump in the industry. Designed for the serious air conditioning and refrigeration technician, the PLATINUM® vacuum pump features a gas ballast and blank off valve. American made and subjected to JB's rigorous performance standards, the PLATINUM® Series is the top of the line for both quality and durability.

Backed by an unprecedented 24 month over-the-counter warranty, there is no better pump on the market. Because each PLATINUM® pump is made at our facility in Illinois, USA quality and dependability are woven in with hard working American pride. Completely field repairable, our PLATINUM® series is designed to last.

24 month warranty

100% field repairable

15 Microns - Vac rating

2-Stage direct drive

100% factory tested



Made in USA

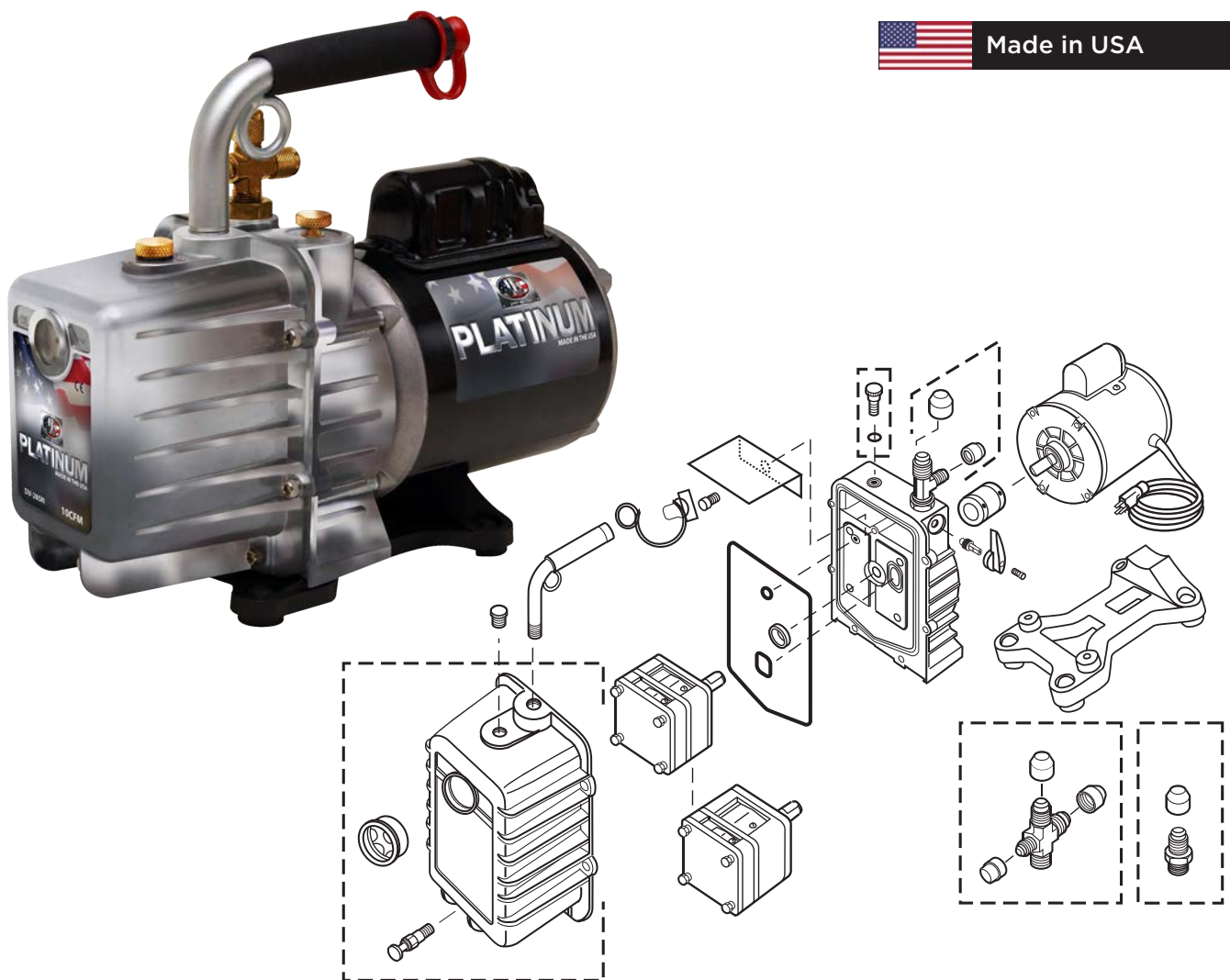

PART NO.	DESCRIPTION
DV142N250AU	240V Platinum Vacuum Pump (120L/m)
DV200N250AU	240V Platinum Vacuum Pump (170L/m)
DV285N250AU	240V Platinum Vacuum Pump (242L/m)

MODEL	DV142N	DV200N	DV285N
VOLUME	120 L/m	170 L/m	242 L/m
MOTOR - 1/2HP	1425 RPM		
VOLTAGE	230v - 50Hz		
INTAKE PORT	1/4"-1/2"-3/8"		
OIL CAPACITY	680ml	680ml	709ml
WEIGHT	14.5kg	14.5kg	15.4kg







## F6 Recovery Unit

The new F6-DP Dual Piston Refrigerant Recovery Unit features a full 1 horsepower motor and is backed by an unsurpassed 3 year OTC warranty. The F6's dual piston compressor and high efficiency micro-channel condenser design recovers refrigerant at industry leading speeds.



3 year OTC warranty

Dual piston compressor

Full 1 horsepower motor

Simple 2 valve operation

Over-sized cooling fan



Made in USA

PART NO.	DESCRIPTION
F6	JB 1HP Dual Piston 240V Recovery Unit



Made in USA



## Quest Leak Detector

The new, easy-to-use QUEST Refrigerant Gas Leak Detector features a long-life, highly sensitive electrochemical sensor and is designed to detect all CFC, HFC, HFO and HCFC refrigerants, and hydrocarbon blends.

- Automatic calibration and reset to ambient levels
- Three adjustable sensitivity levels
- Comfortable neoprene grip
- Rugged carrying case (included)
- Four AA alkaline batteries (included)



PART NO.	DESCRIPTION
LD3000	Quest Leak Detector

## Supernova Digital Vacuum Gauge

JB Industries' SUPERNOVA gauge allows a service technician to be certain when a system is properly evacuated of air and moisture before charging it with refrigerant.

The SUPERNOVA is accurate from 12,000 microns down to 10 microns. The service technician can customise the SUPERNOVA to fit work habits.

- Large, easy to read LCD screen
- Factory calibrated and requires no additional calibration
- Measures in microns PSIA, InHg, pascals, TORR, mTORR and mBARR



PART NO.	DESCRIPTION
DV41AU	Supernova Digital Vac Gauge w/case + AC Adaptor

## Black Gold Vacuum Pump Oil

The gold standard in vacuum pump oil, Black Gold is extremely pure and non-detergent.

It is hydro processed which means it goes through a series of catalytic steps rendering the oil extremely refined, more viscous and more stable. The result is clear mineral oil which will alert you to contamination sooner, as it becomes cloudy or milky. In extreme temperatures, the oil will be more resistant to contaminants.



PART NO.	DESCRIPTION
DV012	Black Gold Vac Oil 946ml
DV024	Black Gold Vac Oil 3.78L

## The Tank

All vacuum pumps require changing oil after every use. Contaminated oil will damage pumps, shortening your pump's working life and preventing deep vacuums from being achieved.

Maintaining clean oil ensures your pump will operate at peak efficiency. This is why you need The Tank - Conveniently change your oil in-between jobs



PART NO.	DESCRIPTION
DVT1	The Tank Oil Caddy for JB Vacuum Pump



## Kobra Hose Sets

Kobra refrigerant hoses are all made with Kevlar – the same material used in bullet proof vests.

They are extremely strong and flexible with a crimp that grips the full circumference of the hose, yielding maximum hold and a uniform seal that prevents leaks. Kobra hoses feature a nitrile cover which is better than neoprene because it is more resistant to oil, giving the hoses longer life.

With a pressure rating of 800 psi working and 4000 psi burst, these hoses can be used with ALL common refrigerants except ammonia. Kobra hoses are packed in a UV resistant bag to stop fading on shelves.

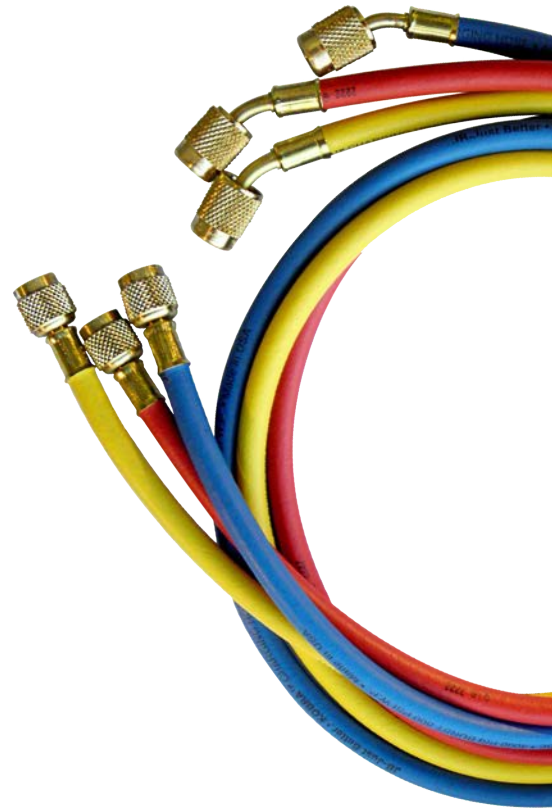

LENGTH	SET	RED	BLUE	YELLOW
<b>Kobra Hoses - 1/4"fl x 1/4"fl</b>				
3'	CCLE36	CLE36R	CLE36B	CLE36Y
6'	CCLE72	CLE72R	CLE72B	CLE36Y
<b>Kobra Hoses - 5/16"fl x 1/4"fl</b>				
3'	CCLE536	CLE536R	CLE536B	CLE536Y
6'	CCLE572	CLE572R	CLE572B	CLE572Y
<b>Kobra Hoses - 5/16"fl x 5/16"fl</b>				
3'	CCLE5536	CLE5536R	CLE5536B	CLE5536Y
6'	CCLE5572	CLE5572R	CLE5572B	CLE5572Y

## Kobra Black Charging Hose

Lined with Kevlar these hoses are tough and dependable, with a 600psi working and 3000psi burst pressure.

PART NO.	DESCRIPTION
CL636	3/8" Charging Hose x 3'
CL672	3/8" Charging Hose x 6'



## Heavy Duty Black Charging Hose

Heavy Duty Charging Hoses reduce permeation and will handle 900psi working and 3500psi burst pressure.

PART NO.	DESCRIPTION
CL6HD60	Heavy Duty Charging Hose 3/8" x 5'
CL6HD72	Heavy Duty Charging Hose 3/8" x 6'





Made in USA



## Flexible Metal Line

Unlike charging hose, our flexible metal lines will not permeate under vacuum and feature finger-tight o-ring coupler ends.

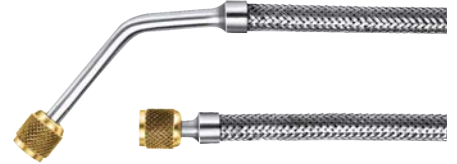

PART NO.	DESCRIPTION
D10660	3/8" x 5' Flexible Metal Line
D10472	1/4" x 6' Flexible Metal Line

## Kobra Hose Spare Parts

PART NO.	DESCRIPTION
P5111	Hose Gaskets
P90514	Hose Depressors



## JB Tube Cutters

JB precision tube cutters for copper tube are designed with smooth running telescopic action for a consistent working radius.

- Rolling stop to protect cutter wheel
- Protected screw spindle to shield against dirt and jamming
- Lightweight cast aluminium body
- Spare cutter stored in handle

PART NO.	DESCRIPTION
RT70020	Copper Tube Cutter 1/8" to 1-1/8" OD
RT70021	Copper Tube Cutter 1/4" to 1-5/8" OD



## Capillary Cutter

The sturdy design of our capillary tube cutter results in no collapsing of the tube which leaves you with a clean cut.

PART NO.	DESCRIPTION
A10973	Capillary Tube Cutting Tool





## Capillary Gauge and File Cutting Tool

Precisely engineered with stainless steel wire plugs. Features a specifically designed file to cut and open tubes.

Fourteen ID sizes from 0.026" to 0.090" and twenty-two OD sizes from 0.072" to 7/16" (2 to 11mm). Use both the ID and OD calibrations to correctly determine tube size. Place tube in "V" slot to measure OD, pin gauge measures ID.

The capillary tube file is designed to cut and open the tube by filing a notch around the tubing at desired cutting point. Simply snap the tube at the notch and clean burrs with the special file tip.



PART NO.	DESCRIPTION
A10971	Capillary Tube Gauge & File in Pouch

## Evacuation/Recovery Tool

A plier-type tool with a quick release trigger which punctures large holes into the line for discharge of a recovery unit. Fits 3/16" to 7/8" OD hard tubing.

PART NO.	DESCRIPTION
A32100	Evacuation/Recovery Tool
A32101	Hardened Steel Needle and Gasket



## Pinch-Off Tool

Temporarily closes off the line while making repairs. The quick release trigger and rounded jaws prevent cutting while allowing for reopening and rounding using a standard flare bar.

PART NO.	DESCRIPTION
T21294	Pinch-Off Tool 1/8" - 5/8"



## Bending Springs

PART NO.	DESCRIPTION
BS4	1/4" Bending Spring
BS6	3/8" Bending Spring
BS8	1/2" Bending Spring
BS10	5/8" Bending Spring
BS12	3/4" Bending Spring





Made in USA



## Service Wrench

Double end reversible ratchet wrenches feature accurately broached multiple openings making them versatile for a number of uses.



PART NO.	DESCRIPTION
T21127U	1/4", 3/16" one end - 3/8", 5/16" other end
T21126U	Offset 1/4", 3/16" one end - 3/8", 5/16" other end

## Braze-Rite Adapter

Nitrogen purging adapter for ACR pipe. Quickly connects to 1/4"fl hose and slips easily and securely into pipe.

Allows for bleed of nitrogen through pipe being brazed, keeping the pipes clean and oxide-free. Fits most common ACR pipe sizes, making it fast to go from one tube to the next. Saves time and money, no more duct taping your hose to the pipes!



PART NO.	DESCRIPTION
BRZ1000	Braze-Rite Adapter

## Valve Core Torque Tool

The new valve core torque tool automatically sets proper torque to 5" pounds.

Calibrated to precise torquing requirements for schrader core valves, the Torque Tool will no longer tighten once proper torque is achieved, Eliminating guess work which results in under or over torquing. Works with all Schrader valve cores.



PART NO.	DESCRIPTION
A32008	Valve Core Torque Tool
A32008BX	Valve Core Torque Tool in Display Box (12 pack)

## Valve Core Remover

Specifically designed to shut-off the system to remove valve core, these tools feature a quarter turn ball valve shut-off and O-ring seals.

The valve core can be completely removed and replaced without losing system charge. Speed up evacuation, recover, or recharging time through the full flow port. Both tools have a storage area to house spare valve cores.



PART NO.	DESCRIPTION
A32525N	1/4"fl VCRT + Access Valve Port



## Core Depressor

PART NO.	DESCRIPTION
A33500	1/4"fl x 1/4" O-Ring Quick Coupler



## Back Seating Control Valve

Ideal for use on pre-charged line sets. Eliminates spraying of leak detection dye and refrigerant. Compact brass body for long service with swivel coupler, which has double safety grooves.

PART NO.	DESCRIPTION
A33000	1/4"fl x 1/4" O-Ring Coupler



## Valve Core Tool

PART NO.	DESCRIPTION
A32004	1/4"fl Valve Core Tool + Core Storage



## Charging Oil Pump

- Pumps 78ml per stroke
- Pumps against 200psi pressure
- Automatic bleed valve equalises pressure
- Can be used on polyol ester, mineral and synthetic oils
- Universal stopper 4L, 10L and 20L containers

PART NO.	DESCRIPTION
OP1	OP1 Oil Transfer Pump



ASPEN  
**EDGE**  
TOOLS

# A2L RECOVERY UNIT

RU12A2L

**ULTRA  
LIGHTWEIGHT  
8.4KG**

**ULTRA  
FAST  
LIQUID  
RECOVERY  
120KG/HR**



Suitability..... HFC/HCFC/GFC  
Push/Pull (kg/hr)... 420  
Vapour (kg/hr)..... 19  
Liquid (kg/hr)..... 120  
Power supply..... 240 V  
Motor size..... 3/4 HP  
HP cut out..... 550 psi (38 bar)  
Compressor..... Oil less  
Dimensions..... 320 x 220 x 260 mm



**ASPEN  
PUMPS**  
ASIA PACIFIC

[ASPENPUMPS.COM.AU](http://ASPENPUMPS.COM.AU)





TRADE TOOLS

SPECTROLINE®

# UV Leak Detection

The world leading manufacturer & inventors of fluorescent leak detection dyes and ultraviolet lamps.



## AR-GLO® 5

In 2019, Spectrolin proudly announced the release of AR-GLO® 5 Fluorescent Dye - our brightest, highest quality, and most advanced dye formula ever.

The new AR-GLO® 5 dye formula fluoresces up to 10% brighter. That's a big improvement and sets us even further apart from other brand formulations on the market.

In addition, AR-GLO® 5 dyes have an increased resistance to extreme temperature ranges and moisture. The bottom line: these quality dyes perform better under difficult conditions and have greater stability, making them the perfect tool for long-term preventative maintenance and leak detection.

The dye has a much greater shelf life. It can be stored up to 150% longer.

**Spectrolin® dyes glow brighter than the competition**



**Fluoresces up to 10% Brighter\***  
Find AC&R leaks quicker & more easily



**Improved Stability**  
More tolerant to extreme temperature range & moisture



**Improved Shelf Life**  
**150% Improvement**  
Up to 5 years



**More Eco-Friendly**  
Formulated with safe raw materials & helps reduce refrigeration emissions into the atmosphere



**Exclusive Formula**  
From the inventors & most trusted name in fluorescent leak detection



## Gloseal - Sticks

GLO Seal™ pinpoints the exact location of all leak areas and seals AC&R micro-leaks from the inside.

GLO Seal™ is concentrated and perfect for fighting corrosion problems, making it a robust find-and-fix solution for AC&R systems. Use GLO Seal™ for 24/7 leak detection and HVAC preventative maintenance.

PART NO.	DESCRIPTION
SPEGSDSCS	Gloseal 2-in-1 UV Dye + Sealant 15ml One Shot Stick (Use with BV50)



## BV50 - One Shot Capsule Installation Kit

PART NO.	DESCRIPTION
BV50	Bleed Valve pkt of 2 1/4"FFL x 1/4"MFL

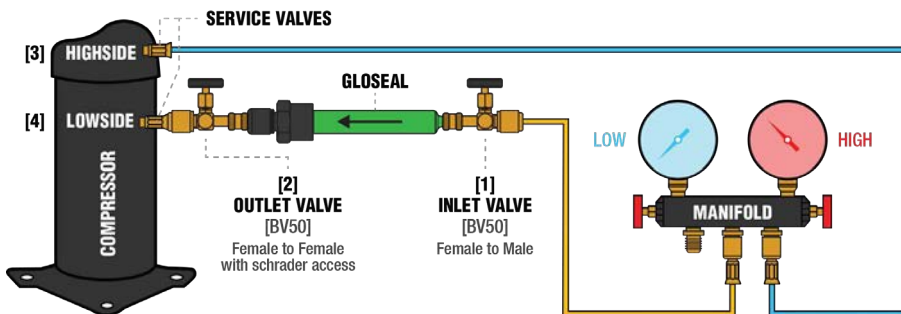

**BRIGHTER DYE** PERFORMANCE  
**CO-SOLVENT FREE**

## Gloseal - Ezject

GLO Seal™ pinpoints the exact location of all leak areas and seals AC&R micro-leaks from the inside.

GLO Seal™ is concentrated and perfect for fighting corrosion problems, making it a robust find-and-fix solution for AC&R systems. Use GLO Seal™ for 24/7 leak detection and HVAC preventative maintenance.

PART NO.	DESCRIPTION
SPEEZDKCS	Gloseal 2-in-1 UV Dye + Sealant // Ezject Injector + 2x 15ml Cartridges
SPEEZDSCS	Gloseal 2-in-1 UV Dye + Sealant 15ml Cartridge





## Glo-Stick Dye Capsules

For small to medium size systems

### Easy to use

Prefilled, disposable capsules allow dye to be injected into pressurized systems using refrigerant

### Clean and precise

The entire contents are washed into the system

### Choice of sizes

Available in 4 sizes/concentrations to match the capacity of the system

### Safe

Will withstand pressures of more than 1000 psi

### HOW IT WORKS

Connect the GLO-STICK capsule between the low-pressure gauge of a charged manifold and the service port using bleed valves. Open the valves slowly to gradually add AR-GLO® into the system and let the dye circulate.

Scan the system with a Spectroline inspection lamp. The precise location of all leaks will be shown by a bright, yellow-green glow.



PART NO.	DESCRIPTION
SPEGS101ECS	ARGLO5 Small System UV Dye 1ml Capsule
SPEGS1ECS	ARGLO5 Residential System UV Dye 14.8ml Capsule
SPEGS2ECS	ARGLO5 Light Commercial UV Dye 14.8ml Capsule
SPEGS3ECS	ARGLO5 Commercial UV Dye 14.8ml Capsule

SYSTEM TYPE	SMALL SYSTEMS (ICE MACHINE, WINDOW AC UNIT)	RESIDENTIAL SYSTEMS	LIGHT COMMERCIAL, LARGE RESIDENTIAL SYSTEMS	COMMERCIAL AND LIGHT INDUSTRIAL, INC. ALL SPLIT SYSTEMS
Refrigeration Oil Charge	Up to 450ml	Up to 1.5L	1.6 to 3.0L	3.1 to 7.6L
Refrigerant Charge	Up to 1.3kg	1.4 to 2.2kg	2.3 to 4.5kg	4.6 to 11.3kg
Kw of Cooling	Up to 3.5kw	3.9 to 7kw	7 to 21kw	21 to 42kw
Part No.	GS101ECS	GS1ECS	GS2ECS	GS3ECS

## BV50 - One Shot Capsule Installation Kit

PART NO.	DESCRIPTION
BV50	Bleed Valve pkt of 2 1/4"FFL x 1/4"MFL

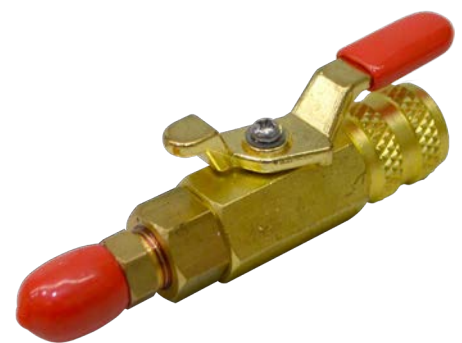
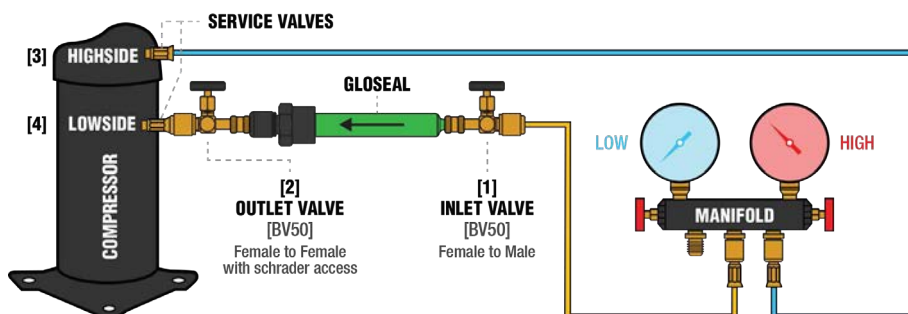



## EZ-Ject Universal Dye Injection Kit

Designed for - Mineral Oil, Polyol Ester and Alkyl Benzene Lubricant Systems

- EZ50 EZ-Ject dye injector assembly
- EZ25 hose assembly with check valve and 1/4" flare low-loss fitting
- 2x EZ4ECS 14.8ml Universal/POE dye cartridges
- 119690 purge fitting
- Service Labels



PART NO.	DESCRIPTION
<b>SPEEZ100ECS</b>	ARGLO5 Universal Dye Injection Kit
<b>SPEEZ5ECS</b>	ARGLO5 Universal/POE Dye Cartridge

SYSTEM TYPE	SMALL SYSTEMS (ICE MACHINE, WINDOW AC UNIT)	RESIDENTIAL SYSTEMS	LIGHT COMMERCIAL, LARGE RESIDENTIAL SYSTEMS	COMMERCIAL AND LIGHT INDUSTRIAL, INC. ALL SPLIT SYSTEMS
<b>Refrigeration Oil Charge</b>	Up to 450ml	Up to 1.6L	1.6 to 3.0L	3.1 to 7.6L
<b>Refrigerant Charge</b>	Up to 1.3kg	1.4 to 2.2kg	2.3 to 4.5kg	4.6 to 11.3kg
<b>Kw of Cooling</b>	Up to 3.5kw	3.9 to 7kw	7 to 21kw	21 to 42kw
<b>No. of Grads on EZ-Ject</b>	1	2	6	8 - 14

## Coolseal - One Shot Capsule

Seals micro leaks in condensers, evaporators, O-rings and hoses. Can add years to older, out-of-warranty AC&R systems that leak small amounts of refrigerant. Works with all popular refrigerants and oils.

- Non-polymer, oil-soluble formula safe for system components and recovery equipment
- Meets ASHRAE 97 standard for chemical stability
- Can be injected with system off or running
- Available in three convenient delivery methods

PART NO.	DESCRIPTION
<b>CS3CS</b>	14.8ml Cool Seal Stick (one shot)



## SPEHVLCS UV LED Torch + Glasses

Leak Finder Ultra Violet LED Torch used with Spectrolin UV Dye

PART NO.	DESCRIPTION
<b>SPEHVLCS</b>	Ultra Violet LED Torch + Glasses
<b>UVS40S</b>	Safety Glasses - Fluro Enhancing



## LF500CS UV Torch

Leak Finder Ultra Violet LED Torch used with Spectrolin UV Dye

PART NO.	DESCRIPTION
<b>LF500CS</b>	UV LED Torch + Safety Glasses





# Brazing Torches

With their lightweight design, high heat output and reliability, Express tools allow technicians to perform higher quality installations and a better finished product.



## Vulcane Express Pro Torch

With its MAP//Pro cartridge, a heating temperature of 2,400°C and power output up to 3.5 kW (Ø 28 nozzle), the VULCANE EXPRESS uses its wrap-around turbo flame to optimise heat distribution round the circumference of the pipe being heated.

Its high efficiency and the absence of a false flame guarantee exceptional performance - down to the very last gram of gas!

Its light 400g weight and high comfort index rating make it easy to handle. The ergonomic bi-material handgrip and overall design efficiency give it its unique style and it looks really good!

3 position control makes the Vulcane Express Pro Torch simple to use:  
**1 - Assembly/Dismantling | 2 - Safety Lock | 3 - Operating Mode**

With just one click of the dual-mode ignition trigger, operations can be switched from continuous to intermittent.



PART NO.	DESCRIPTION	BURNER GUIDE	BURNER 14	BURNER 22	BURNER 28	BURNER 35
PTV472	Pro Torch with 22mm Burner	Gas Consumption (g/h)	153	200	253	-
PTV485	Pro Torch with 35mm Burner	Power (kW)	2.1	2.7	3.5	-
		BTU	7157	9417	11912	-
		For tube up to	Ø16mm	Ø22mm	Ø28mm	Ø35mm



## Vulcane Express Blow Torch

The multifunction Vulcane Blow Torch has been designed for copper brazing and tin brazing. With its piezo ignition, as well as an ergonomic handle for a better grip, the Vulcane Blow Torch is practical and easy to use.

Guaranteed for 2 years - with a solid metal bell jar, this Blow Torch is built to last.

**Flame Temp: Approx. 1850°C**

PART NO.	DESCRIPTION
PTV8900	Vulcane Blow Torch



## Stop Flame Safety Pad

The Stop Flame Safety Pad is used to protect the splash area around where you are brazing from the flame.

This product is made to exceptional quality and resists heat like you wouldn't believe. Being quite flexible, the pad is able to be folded and bent, making it perfect for awkward jobs.

The Standard Protect Flame Pad offers good protection and is slightly larger in size.

PART NO.	DESCRIPTION
PTV5450	Premium Stop Flame Pad (200x250mm)
PTV5451	Premium Protect Flame Pad (210x297mm)



## Gas Cartridges

PART NO.	DESCRIPTION	QTY/CTN
MAPP	Mapp Gas - Suits Vulcane Pro Torch	12
PTV8185	Butane Gas - Suits Vulcane Blow Torch	12





TRADE TOOLS



# Portable Lifter

The CM439 Lifter quickly and easily turns a 3 person lifting job into a single person job giving your company an edge over its competitors.

Adjustable legs enable the CM439 to work on uneven surfaces and fold compactly. The CM439 can lift a maximum weight of 130kg and can lift to a height of 4.27 meters.



SPIRIT LEVEL

PART NO.	DESCRIPTION
CM439	Height Range 1.15m - 4.27m



240V TRIGGER CONTROL



CORDLESS DRILL 17mm



CRANK HANDLE



# HVACR CHEMICALS

- 111** Advanced Chemicals
- 116** Nu-Calgon Chemicals
- 123** Indoor Air Quality





# Advanced Chemicals

World class cleaning chemicals for the sustained protection of people, buildings and equipment

Advanced is the recognised market leader in specialist HVAC/R cleaning chemicals, supplying the industry for over 35 years. Our research and development team have created a range of chemical cleaning products which are trusted by engineers and designed to give optimum cleaning performance across a variety of applications and environments.

## Anti-Biofilm Jally Strips

Condensate tray microbial control. Jally Strips are condensate tray treatment providing up to 12 months protection from slime build up caused by bacteria, fungi, algae and other micro-organisms. The large sized Jally Strips are designed specifically for use on large cooling systems. When used correctly, Jally Strips are safe to use in food preparation and storage areas.

- Slime dispersing action for refrigeration systems
- Smart release - extra biocidal power when needed
- 12 months protection
- Safe to use in food preparation areas



PART NO.	DESCRIPTION
S010371AU	Jally Strips (8pk)
S010370AU	Jally Strips (50pk)

Hazardous transport.



## ECD - Evaporator Cleaner & Disinfectant

- Kills 99.9% of odour producing bacteria
- Powerful cleaning action will remove bacteria, dirt, slime and mould
- Improves energy efficiency of unit
- Condensate pump safe

PART NO.	DESCRIPTION	SIZE
<b>S010458AU</b>	AdvancedGel ECD	490ml



## CC - Condenser Cleaner

- Cleans even the most stubborn baked on deposits
- Leaves coils clean and visibly brighter
- Safe to use on aluminium or copper coils

PART NO.	DESCRIPTION	SIZE
<b>S010457AU</b>	AdvancedGel CC	490ml



## UC - Universal Coil Cleaner

- Powerful & effective cleaning against common dirt, including dust, lint & grease
- Biodegradable and environmentally friendly
- Improves energy efficiency of unit
- Condensate pump safe

PART NO.	DESCRIPTION	SIZE
<b>S010459AU</b>	AdvancedGel UC	490ml





## HydroSprayer Elite

- 15L tank capacity which is packaged as a back pack with supportive straps
- A 12V long-life rechargeable battery
- Powerful automatic pump that produces 60 psi at the squeeze of a trigger
- Use with Advanced concentrated and ready-mixed coil cleaner chemicals, both indoors and outdoors
- Wand options included: 500mm, 1000mm and 1500mm
- Long lasting Viton seals



PART NO.	DESCRIPTION	SIZE
S010450AU	Hydosprayer-Elite	15L

Not suitable for cleaners containing hydrochloric acid  
\*Spare parts available



## Power Pressure Spray Bottles

Hand pump pressure spray bottles with high quality seals.

PART NO.	DESCRIPTION
SC9090	1L Spray Bottle
SC9100	5L Spray Bottle
SC9110	10L Spray Bottle



## SPRAY 2L

PART NO.	DESCRIPTION
SPRAY2L	NC Spray Bottle 2L





## Evaporative Cleaners

PART NO.	DESCRIPTION	CONTAINER SIZE
S010166R7	Condencide - Bottle Evaporator Cleaner & Disinfectant	5L
S010127R7	EasyCare - Aerosol Evaporator Cleaner & Disinfectant	600ml
S090049R7	EasyFresh - Aerosol Odour Neutraliser for AC systems	400ml
S010196R7	RTU ECD - RTU Spray Bottle Evaporator Cleaner & Disinfectant	1L
S090070R7	OdourGuard - RTU Spray Bottle Odour Eliminator for A/C Systems	1L



## Condenser Cleaners

PART NO.	DESCRIPTION	CONTAINER SIZE
S010195R7	RTU CC - RTU Spray Bottle Condenser Cleaner	1L
S010171R7	SuperClean - Bottle Heavy-Duty Condenser Cleaner	5L
S010132R7	EasyFoam - Aerosol Heavy-Duty Condenser Cleaner	600ml



## Drain Maintenance

PART NO.	DESCRIPTION	CONTAINER SIZE
S010106	DrainKleen One Shot - Bottle w/spout Condensate Drain Unblocker	250ml
S010188R7	DrainKleen - Bottle Condensate Drain Unblocker	5L



## Universal Cleaners

PART NO.	DESCRIPTION	CONTAINER SIZE
S010128R7	EasyClean - Aerosol Universal Coil Cleaner	600ml





## Refrigeration & Ice Machines

PART NO.	DESCRIPTION	CONTAINER SIZE
S010209R7	Ice 'n' Clean - Bottle Nickel Safe Ice Machine Cleaner	1L
S010169R7	Ice 'n' Clean - Bottle Nickel Safe Ice Machine Cleaner	5L



## Specialist Chemicals

PART NO.	DESCRIPTION	CONTAINER SIZE
S010129R7	EasyCoat - 600ml Aerosol Acrylic Protective Coating for Coils	600ml
S010131R7	EasyFinish - 600ml Aerosol Fascia & Case Cleaner	600ml
S050004R7	PyroCool - 1 Litre Bottle Heat Dissipating & Flame Retardant Spray	1L
S010386AU	JallyStrips - 1 tray of 50 strips Condensate Tray Microbial Control	Tray
S010173R7	RTU-BU - RTU Spray Bottle Bubble Up Leak Detector	1L
S010350R7	EasyFind - Aerosol Bubble Up Leak Detector	400ml



## VerteX

Adaptive cleaner for any type of dirt. Quickly removes grease, fat, rust & scale. Non corrosive - Neutral pH7. Neutralises all unpleasant malodour. Ideal for micro channel & coils with protective coatings.

PART NO.	DESCRIPTION	SIZE
S010389AU	VerteX - Bottle PH7 Universal Cleaner	5L





# Coil Cleaner Selection Guide



	Nu-Brite®	Tri-Pow'r® HD	Evap-Fresh® No Rinse	Evap-Pow'r®-C	Green Clean	Evap-Foam®	Blackhawk®
<b>EQUIPMENT USED ON</b>							
Condenser Coils	•	•			•		•
Mini-Split Condenser Coils		•			•		•
Small Condenser Coils	•	•			•		•
Evaporator Coils		•	•	•	•	•	•
Mini-Split Evaporator Coils		•	•	•	•	•	•
Small Evaporator Coils		•	•	•	•	•	•
Microchannel Coils		•	•	•	•	•	•
Electronic Air Filters							
Fan Blades, Permanent Filters		•		•	•	•	•
<b>FORMULATED TO REMOVE</b>							
Greasy Dirt and Oil	•	•		•	•	•	•
Cooking Grease	•	•					•
Lint, Dust, Dirt and Grime	•	•	•	•	•	•	•
Tobacco Tars							
Oxide (Corrosion) Deposits	•						
Cottonwood/Bugs	•						
<b>FEATURES AND BENEFITS</b>							
Product Type		Alkaline	Alkaline	Alkaline	Alkaline	Alkaline	Alkaline
Foaming	•		Aerosol	Liquid		•	•
Brightening	•						
Degreasing	•	•			•		•
EPA Registered Disinfectant			•	•			
No Rinse (Evaporators)		•*	•	•	•*	•	•
No Rinse (Condensers)							
Biodegradable	•	•	•	•	•	•	•
USDA Authorized	•			•			
U.S. EPA's Safer Choice Program					•		
NSF Registered	•	•				•	•

\*Dilution ratios for no rinse applications: Tri-Pow'r HD = 10:1, Green Clean = 10:1



# Nu-Calgon Chemicals

## Nu-Brite®

Nu-Brite is the most effective coil cleaner available today. It foams, brightens, and cleans more effectively than acids, particularly in removing grease. Biodegradable. The liquid versions are USDA approved and NSF registered.

PART NO.	DESCRIPTION
4291-08	3.78Ltr NU-BRITE COIL CLEANER



## Evap Pow'r®-C

A no-rinse product formulated for cleaning evaporator coils, Evap Pow'r-C is metal-safe, and it cleans and emulsifies even the most stubborn soils and deposits. Biodegradable. USDA approved. Also great for microchannel coils.

PART NO.	DESCRIPTION
4168-08	3.78Ltr EVAP COIL CLEANER





## Tri-Pow'r® HD

Tri-Pow'r HD is an outstanding general purpose coil cleaner, providing detergency and degreasing as well as deodorizing capability. Its positive emulsion technology is very effective against oily grime as it converts the deposits into a more liquid form that can be easily rinsed. It is non-acid, non-toxic, and biodegradable. NSF registered. Also great for microchannel coils.

PART NO.	DESCRIPTION
4371-88	3.78Ltr TRI POW'R HD EVAP + COIL CLEANER



## Green Clean

Green Clean is a pleasantly scented, all-purpose, environmentally friendly cleaner designed for the rapid removal of grease and other heavy soils on coils and other surfaces. It can be used right out of the bottle or diluted for milder jobs. Biodegradable. Also great for microchannel coils.

PART NO.	DESCRIPTION
4186-08	3.78Ltr GREEN CLEAN ALL PURPOSE (BOTTLE)
4186-24	946ml GREEN CLEAN ALL PURPOSE (SPRAY)



## Coil Gun® and Coil Gun® Probe

Coil Gun is a "hose-end" sprayer that features five different mix ratio settings designed for coil cleaners. Utilizes a 2 quart capacity bottle and includes a foam wand as well as "quick disconnect" capability. The Coil Gun Probe accessory has a 90° direction of spray that allows cleaning from inside the coil. It also provides easy access in tough-to-reach locations.

PART NO.	DESCRIPTION
4774	COIL GUN SPRAY BOTTLE
4774-1	COIL GUN PROBE



## Nu-Shield™

PART NO.	DESCRIPTION
4294-75	NU-SHIELD INDOOR COIL PROTECTOR (CLEAR)







The brand you trust

CHEMICALS

Nu-Calgon

## Blackhawk®

Blackhawk is an expanding foam coil cleaner formulated to deeply penetrate the coil. It liquefies to quickly remove grease, grime, or oily soils from deep within the coil. Blackhawk's formulation is safe and problem-free for cleaning evaporator or condenser coils in an occupied building; produces no objectional fumes. It is particularly effective on coils on refrigerators, coolers, and freezers located in restaurants and other commercial establishments. NSF registered. Can be used with Talon Flexible Aerosol Wand (4776-0) for hard to reach locations.

PART NO.	DESCRIPTION
4127-75	BLACKHAWK FOAM COIL CLEANER 511g (AEROSOL)



## Evap-Fresh® No Rinse Evaporator Coil Cleaner & Disinfectant†

Evap-Fresh is a ready-to-use, no-rinse cleaner and disinfectant for evaporator coils. It effectively cleans, as well as controls, mold and bacteria. This one-step no-rinse disinfectant cleaner is perfect for air conditioners, commercial air handling units, HVAC cooling coils, refrigeration equipment, and evaporator coils. EPA registered specifically for use on HVAC equipment. Aerosol can be used with Talon Flexible Aerosol Wand (4776-0) for hard to reach locations.

PART NO.	DESCRIPTION
4166-75	532ml EVAP FRESH NO RINSE (AEROSOL)
4166-08	3.78Ltr EVAP FRESH NO RINSE (BOTTLE)



## Cleaning Bag

PART NO.	DESCRIPTION
4150-01	MINI SPLIT LARGE CLEANING GUARD (UP TO 3.5KW)
4150-02	MINI SPLIT EXTRA LARGE CLEANING GUARD (UP TO 10KW)
4150-03	CLEAN GUARD CC - COMMERCIAL CEILING CASSETTES





## PanPads

PanPads are formulated to eliminate the build-up of bacteria and slime growth in air conditioning and refrigeration condensate drain pans. In laboratory tests, they have been proven effective against a wide spectrum of harmful bacteria, including Legionella. The product is EPA registered for this application. NSF registered.



PART NO.	DESCRIPTION	PART NO.	DESCRIPTION
4295-34	5 (up to 17.5KW)	4296-24	15 (up to 52.5KW)
4295-36	5 Slim (up to 17.5KW)	4296-45	45 (up to 157.5KW)

## Gel Tabs™

Formulated with a breakthrough technology for treating air conditioning drain pans and lines. Keeps the drain pan from clogging and eliminates foul and musty odors. When activated by condensation, the tablet will turn to gel and lock into place. Dissolves continuously and completely for up to three months. Stack together to increase duration.



PART NO.	DESCRIPTION	PART NO.	DESCRIPTION
4185-03	10.5KW (3 ton) tab	4185-20	70KW (20 ton) tab
4185-05	17.5KW (3 ton) tab	4185-04	200 ct. Bulk (3 ton) tab
4185-15	52.5KW (15 ton) tab		

## EasySeal Direct Inject

The EasySeal® line has proven to be the number one trusted leak sealant brand for years, with millions of leaks sealed. Now Nu-Calgon has made EasySeal even better with EasySeal Ultimate – the strongest and fastest leak sealant on the market, now with the ability to treat systems up to 10 tons in one application.



PART NO.	DESCRIPTION
4050-05	EasySeal Direct Inject up to 7kW
4050-08	EasySeal Direct Inject from 7kW to 35kW
4050-11	EasySeal Direct Inject with UV Dye from 7kW to 26kW
4050-21	EasySeal Direct Inject with UV Dye up to 7kW

## Rx-Acid Scavenger®

The most effective way to neutralize or “scavenge” acid in refrigeration and air conditioning systems. Rx-Acid Scavenger is perfect for use after burnouts or during normal on-going system maintenance. In addition, Rx-Acid Scavenger can be used with all lubricants: mineral, alkylbenzene, and polyol ester. Now available in a pressurized can for easy injection into charged systems or hermetically sealed systems. Connect Inject version is a quick, injectable treatment that uses the Connect Injector Tool.



PART NO.	DESCRIPTION
4301-02	59ml RX-ACID SCAVENGER



The brand you trust

CHEMICALS

Nu-Calgon

## Phase III® Refrigeration Oil Acid Test Kit

Formulated for use with POEs as well as mineral oils and alkylbenzene, Phase III is an inexpensive, disposable test kit that provides proof-positive that acid level in refrigeration oil is either safe or unsafe. Phase separation makes it easy to see change in color of acid indicator (even if a leak detection dye has been added to the oil). With just two bottles to use, it is simple, safe, accurate, and small enough that you can carry several in your tool box.



PART NO.	DESCRIPTION
4320-W8	PHASE III ACID TEST KIT

## Nu-Foam®

Nu-Foam is double expansion polyurethane foam with all-direction dispersing. Used as a sealant and insulating product on openings created for refrigeration, air conditioning and heating tubes or pipes, duct joints, and other areas where unwanted air penetration might occur. Contains no CFCs or HCFCs, and is fire retardant and UL listed.



PART NO.	DESCRIPTION
4293-04	NU FOAM 340g AEROSOL

## Liquid Ice Machine Cleaner

Liquid Ice Machine Cleaner is a food-grade phosphoric acid that is fast acting, yet safe to use. It has been formulated to remove scale deposits from ice machines and coffee urns. It does not give off any harsh fumes or contain chlorine or chlorides that would attack stainless steel. USDA approved. NSF registered.



PART NO.	DESCRIPTION
4207-47	LIQUID ICE MACHINE CLEANER 236ml

## Nickel Safe Ice Machine Cleaner

The original Nickel-Safe Ice Machine Cleaner. It is a food-grade citric-phosphoric acid product for removing scale deposits from ice machines having nickel-plated or tin-plated evaporators, and it is acceptable for use in all ice machines containing nickel. It mixes to form a green solution, which makes rinsing easier. USDA approved.



PART NO.	DESCRIPTION
4287-08	3.78Ltr NICKEL SAFE ICE MACHINE CLEANER
4287-34	500ml ICE MACHINE SANITIZER



## Cal-Blue® Plus

Cal-Blue Plus is a complete gas leak detector with freeze protection to 5°F. Its high viscosity formula enables it to remain in contact with the applied surface for an extended period of time, allowing it to detect the smallest of leaks. The longest lasting bubbles in the industry! It is also non-corrosive to metal, and it will not affect ultraviolet or black lights. Now available in a non-aerosol pressurized container that can be sprayed at any angle! NSF registered.



PART NO.	DESCRIPTION
4182-08	3.78Ltr CAL-BLUE BUBBLE LEAK DETECTOR
4182-24	946ml CAL-BLUE BUBBLE LEAK DETECTOR SPRAY

## Great Wipes

Great Wipes Industrial Strength Hand Towels are waterless wipes made specifically for the air conditioning, refrigeration, and plumbing service technician. Each premoistened, heavy duty towel has strong pumice scrubbing power that conveniently cleans anywhere and anytime.



PART NO.	DESCRIPTION
4185-75	GREAT WIPES INDUSTRIAL STRENGTH 75 PACK

## Pan-Spray®

Pan-Spray is an effective, easy-to-use waterproof rubberized coating that won't chip, flake, or peel. It's ideal for sealing out rust and corrosion as well as repairing leaky condensate pans, cooling towers, swamp coolers, roofing, gutters, and down spouts. Pan Spray is the perfect solution for emergency and permanent repair.



PART NO.	DESCRIPTION
4296-50	473ml WHITE PAN-SPRAY LEAK SEALER
4296-51	473ml BLACK PAN-SPRAY LEAK SEALER



# ClenAir™ by Nu-Calgon

We all want clean, odor free air from the heating and air conditioning systems in our homes or buildings.

At home, school, work, or play, the quality of the indoor air that we breathe affects the way we feel. The indoor air handler is the heart of the HVAC system. The air handler's cooling/heating coils, and condensate drain pan must be properly treated and maintained in order for it to supply clean, odor free, conditioned air to the home or building. ClenAir's Quality Indoor Air Program provides the products to treat the cooling/heating coils, condensate drain pan, and HVAC system air as it passes through the air handler. Breathe Easy With ClenAir!

## Clen Air Spray Deodorising Spray

ClenAir Liquid Formulas are a fast-acting deodorizing system. Unlike regular deodorizers that simply use heavy perfumes and oils to disguise odors, ClenAir eliminates odors via an oxidation process while leaving a fresh scent. ClenAir is also biodegradable, non-toxic, non-staining, and approved for usage in homes and businesses.

PART NO.	DESCRIPTION
61030	Clen Air Spray Deodorising Spray Unsented 473ml
61033	Clen Air Spray Deodorising Spray Citrus 473ml
61037	Clen Air Spray Deodorising Spray Cherry 473ml





## ClenAir™ Odor Neutralizer

ClenAir's unique odor neutralizing formula removes odors quickly and permanently. It is a true odor eliminator, not a mask. Originally designed for use in central air systems, on fire and flood restoration jobs and in sewage facilities, ClenAir is a professional product, yet it leaves no lingering antiseptic or perfume smell. It is great for odors caused by fuel oil, smoke, pets, mold and mildew, cigarette and cigar smoke, decay, cleaning solvents, and even skunks. ClenAir has three different scents: Original, CherryAir, and OrangeAir. The scents come in multiple sizes for multiple applications.



PART NO.	DESCRIPTION
61001	Original Odor Neutralizer 227g
61003	Original Odor Neutralizer 454g

## CherryAir™ Odor Neutralizer

CherryAir Odor Neutralizer removes odors quickly and permanently leaving a pleasant Cherry fragrance behind. Using unique ClenAir odor neutralizing technology, Cherry-Air is a true odor eliminator - not an odor mask like many scented products. Cherry-Air attacks odors caused by fuel oil, smoke, pets, mold and mildew, cigarette and cigar smoke, decay, cleaning solvents, and even skunks!



PART NO.	DESCRIPTION
61010	Cherry Odor Neutralizer 227g

## OrangeAir™ Odor Neutralizer

OrangeAir - Using the unique ClenAir odor neutralizing technology, OrangeAir safely eliminates odors leaving a refreshingly crisp Orange fragrance behind. OrangeAir is not a mask or cover-up. It is a true odor eliminator. OrangeAir eliminates odors caused by smoke, pets, fuel oil, mold, mildew, bacteria, cigarette smoke, water damage, fire damage, stale air, decay, chemicals, even skunks!



PART NO.	DESCRIPTION
61020	Orange Odor Neutralizer 227g



The brand you trust

CHEMICALS

**Nu-Calgon**

## Residential Odor-Block

ClenAir HVAC Odor Block is not a perfume mask or cover-up. The unique ClenAir formula molecularly reacts with the airborne odor-causing compounds and eliminates them and other indoor pollutants, leaving clean, fresh air behind. The HVAC Odor Block makes it easy to remove odors and improve the indoor air quality in the entire home or building by treating the air through the HVAC system. Use in A/C units, furnaces, rooftop units, fan coil units, and air handlers. Part numbers 61060 and 61061 last up to 3 months. The HVAC Odor Block XL (61070) lasts up to 6 months.



PART NO.	DESCRIPTION
61060	Residential HVAC Odor Block
61061	Commercial HVAC Odor Block

## ClenHands Orange Crush™

Premium antimicrobial hand cleaners that quickly dissolve dirt, grease, fuel oil, pipe dope, resin, ink, paint, glue, rubber gasket and tile cements, and many other hard-to-remove soils. ClenHands Orange Crush is enhanced with fine-ground American pumice. For use with or without water.



PART NO.	DESCRIPTION
61203	443ml Orange Crush Hand Cleaner

## A/C Drain Sucker™

A/C condensate drain pan overflow is caused by slime and sludge that builds up and clogs the drain line. The A/C Drain Sucker quickly removes the clog and the excess water, resolving the overflow problem. The kit includes a PurCool® Green 3 ton tablet to provide months of preventive treatment and free flowing drains, as well as all fittings and hoses for suction or pressure applications.



PART NO.	DESCRIPTION
61308	A/C Drain Sucker Kit

## PurCool® Condensate Pan Treatment Tablets

PurCool Tablets utilize a powerful formulation to keep condensate drain pans clean and free flowing. Use PurCool Tablets to remove sludge and slime in A/C condensate pans to prevent costly water damage caused by overflows. They will control clogs, build-up, odors, and corrosion in drain pans, condensate pumps, and humidifiers.



PART NO.	DESCRIPTION
61053	200 PurCool Tablets



## PurCool® Green Strips

PurCool Strips prevent sludge, odors, and overflow of condensate pans. Time release formula adheres to pan and fully dissolves over time. PurCool Green Strips use plantbased suspending and dispersing action to keep drain pans clean and free flowing. Products are available for commercial, residential, and mini split applications. Sizes are based on system tonnage, with each strip lasting up to six months. Biodegradable and environmentally friendly. Will not harm aquatic life.



PART NO.	DESCRIPTION
61044	Mini Strip - treats up to 17.5KW (5 tons)
61045	Commercial Strip - treats up to 35KW (10 tons)
61046	Commercial Strip - treats up to 105KW (30 tons)

## A/C Shine™ Superior Cleaner/Protectant

A/C Shine is specially formulated to clean and protect the painted metal surfaces of outdoor A/C condensing units. It sprays on and wipes off quickly and easily without water. For use on all outdoor unit painted surfaces.



PART NO.	DESCRIPTION
61118	A/C Shine 341g (Aerosol)

## Spray Nine® Cleaner and Disinfectant

Spray Nine is a tough task cleaner and broad spectrum disinfectant. EPA-registered disinfectant kills harmful germs like HIV-1, Influenza, H1N1, Staphylococcus Aureus, Salmonella Choleraesuis and E. Coli in 45 seconds. Also helps prevent cross contamination. Authorized by USDA for use in federally inspected meat and poultry plants with a C-1 rating.



PART NO.	DESCRIPTION
61113	Spray Nine 946ml Spray Bottle
61110	Spray Nine 3.8L Bottle

## Smoke Pen

Smoke Pens are excellent for observing ventilation, air balancing, smoke detectors, drafts, leakage, and air flow. Smoke tests will effectively and inexpensively reveal leaks in heating and air conditioning duct work, furnaces, fire boxes, exhaust fans, and smoke detectors.



PART NO.	DESCRIPTION
61305	Smoke Pen
61306	Refill Package - 6 Wicks



Advanced 

# HydroSprayer-Elite<sup>®</sup>

*Battery-Power Electric Sprayer*



Distributed by



**ASPEN  
PUMPS**  
ASIA PACIFIC



# INSTALLATION & SERVICE ACCESSORIES

- 134** Services Accessories
- 134** Evap Super Pump
- 135** Duct Tape



# Springseal Pipe Flashings

Springseal Pipe Flashings are made from flexible EPDM and won't crack, this allows for easy expansion, contraction and pipe vibration.

The aluminium base makes them versatile and flexible for most roofing sheet profiles.

## Black EPDM - Square Base

PART NO.	DESCRIPTION
SPFRT1	No.1 Black Pipe Flashing (0 - 55mm)
SPFRT2	No.2 Black Pipe Flashing (3 - 100mm)
SPFRT3	No.3 Black Pipe Flashing (80 - 175mm)
SPFRTMINI	Mini Black Pipe Flashing (0 - 35mm)

Temperature Range: -60°C to +115°C

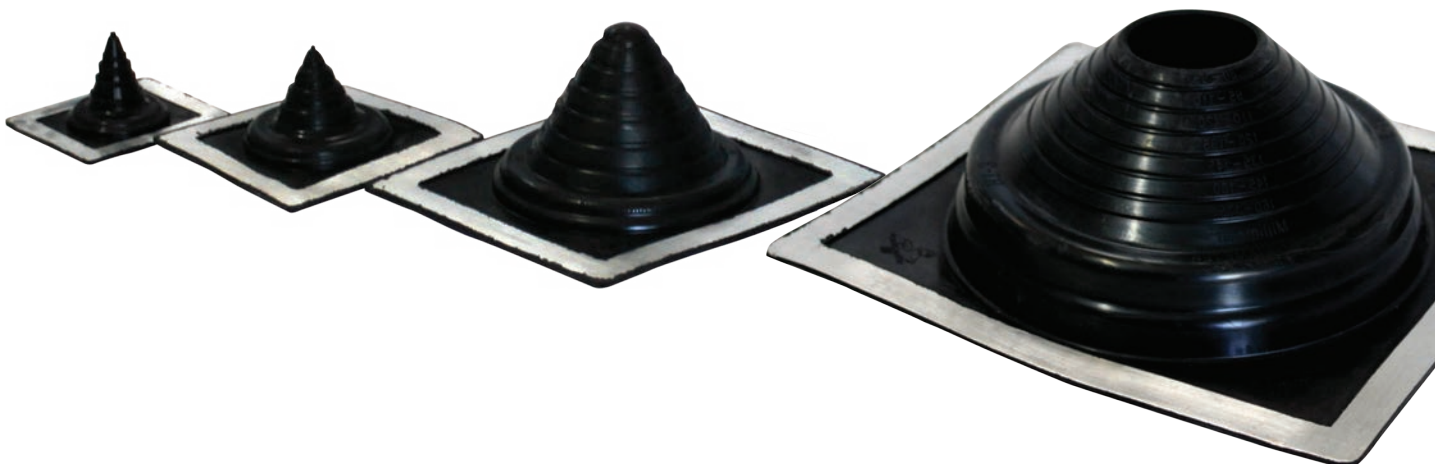



## Grey EPDM - Round Base

Springseal Pipe Flashings are made from flexible EPDM and won't crack, this allows for easy expansion, contraction and pipe vibration.

The aluminium base makes them versatile and flexible for most roofing sheet profiles.



PART NO.	DESCRIPTION
SPF660	No.1 Grey Pipe Flashing (6 - 60mm)
SPF5080	No.2 Grey Pipe Flashing (50 - 80mm)
SPF60110	No.3 Grey Pipe Flashing (60 - 110mm)
SPF75150	No.4 Grey Pipe Flashing (75 - 150mm)
SPF110170	No.5 Grey Pipe Flashing (110 - 170mm)
SPF140210	No.6 Grey Pipe Flashing (140 - 210mm)

Temperature Range: -60°C to +115°C



## Grey EPDM - Round Base

Designed to be installed on existing pipework, Zipseals come with their own clips which are used to secure the pipe flashing together. Simply crimp with a pair of pliers or multigrips.

PART NO.	DESCRIPTION
SPFZ2070	No.1 Zipseal Pipe Flashing (20 - 70mm)
SPFZ50190	No.2 Zipseal Pipe Flashing (50 - 190mm)

Temperature Range: -60°C to +115°C



## Red Silicone - Rectangular Base

These high temperature Pipe Flashings can handle up to 200°C.

PART NO.	DESCRIPTION
SPFSILRT2	No.2 Red Pipe Flashing (3 - 100mm)
SPFSILRT3	No.3 Red Pipe Flashing (80 - 175mm)

Temperature Range: -60°C to +200°C





# KEY



## Key Capillary

### Capillary Tubing Service Packs

Convenient range of all popular capillary sizes the service packs are made from high quality tubing which is drawn down to strict dimensional tolerances.

PART NO.	ID (mm/inch)	OD (mm)	Length (mm)
SP1	0.65/0.0260	1.80	3660
SP2	0.80/0.0315	2.06	3660
SP3	0.90/0.0335	2.18	3660
SP4	1.10/0.0435	2.16	4270
SP4.5	1.20/0.0472	2.26	4270
SP5	1.30/0.0510	2.58	4270
SP6	1.40/0.0550	2.70	3660
SP6.5	1.50/0.0591	2.82	3660
SP7	1.62/0.0640	2.94	3050
SP8	1.78/0.0700	3.10	3660
SP9	1.90/0.0750	3.06	2750
SP10	2.04/0.0800	3.44	3050
SP11	2.24/0.0880	3.54	3660





## Capillary Coils - 30 & 100m Rolls

All capillary tubes are manufactured from Phosphorous-deoxygenated copper. This high quality tubing plug is drawn to ensure strict dimensional tolerances to standard are held throughout its length.



**PROUDLY  
AUSTRALIAN  
MADE  
AND  
OWNED**

PART NO. (30m)	PART NO. (100m)	ID (mm/inch)	OD (mm)
CAP30SP1	CAP100SP1	0.66/0.0260	1.72
CAP30SP1.5	CAP100SP1.5	0.70/0.0276	1.80
CAP30SP2	CAP100SP2	0.80/0.0315	2.06
CAP30SP3	CAP100SP3	0.90/0.0335	2.18
CAP30100	CAP100100	1.00/0.0394	2.28
CAP30SP4	CAP100SP4	1.10/0.0435	2.16
CAP30SP4.5	CAP100SP4.5	1.20/0.0472	2.26
CAP30124	CAP100124	1.24/0.0488	2.52
CAP30SP5	CAP100SP5	1.30/0.0510	2.58
CAP30137	CAP100137	1.37/0.0539	2.65
CAP30SP6	CAP100SP6	1.40/0.0550	2.70
CAP30SP6.5	CAP100SP6.5	1.50/0.0591	2.82
CAP30SP7	CAP100SP7	1.62/0.0640	2.94
CAP30SP8	CAP100SP8	1.78/0.0700	3.10
CAP30182	CAP100182	1.82/0.0717	2.88
CAP30SP9	CAP100SP9	1.90/0.0750	3.10
CAP30SP10	CAP100SP10	2.04/0.0800	3.44
CAP30SP11	CAP100SP11	2.24/0.0880	3.54
CAP30230	CAP100230	2.30/0.0905	3.60
CAP30281	CAP100281	2.81/0.1106	3.97
CAP30333	CAP100333	3.33/0.1311	4.75



## Capillary Adaptors

PART NO.	ID (mm)	OD (mm)	Length (mm)
14870	±1.82	±2.88	1000
145378	±1.78	±3.10	1500

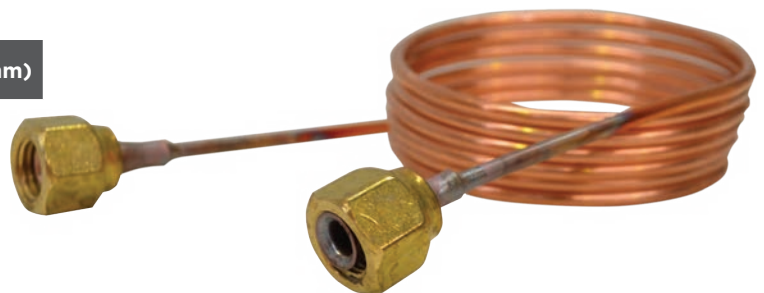



Made in USA



INSTALLATION & SERVICE ACCESSORIES

## Access Valves

PART NO.	DESCRIPTION
A31003	1/4"FL Schrader x 3/16" ODS Access Valve (5pk)
A31003100	1/4"FL Schrader x 3/16" ODS Access Valve (100pk)
A31004	1/4"FL Schrader x 1/4" ODS Access Valve (5pk)
A31004100	1/4"FL Schrader x 1/4" ODS Access Valve (100pk)
A31004101	1/4"FL Schrader x 1/4" ODS Access Valve (1000pk)

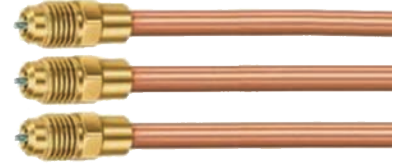

## Valve Cores

PART NO.	DESCRIPTION
A31003	1/4"FL Schrader x 3/16" ODS Access Valve (5pk)
A31003100	1/4"FL Schrader x 3/16" ODS Access Valve (100pk)
A31004	1/4"FL Schrader x 1/4" ODS Access Valve (5pk)
A31004100	1/4"FL Schrader x 1/4" ODS Access Valve (100pk)
A31004101	1/4"FL Schrader x 1/4" ODS Access Valve (1000pk)



## Swivel Tees

PART NO.	DESCRIPTION
A31852	1/4"FL Swivel Tee with Depressor - Nut On Branch (3pk)
A31851	1/4"FL Swivel Tee with Depressor - Nut On Run (3pk)



## R410a Adaptor

PART NO.	DESCRIPTION
A31665	1/4" Female x 5/16" Male Adaptor R410a





# Service Accessories



## Super Pump - Evaporative Cooler Pump

- Available in 3 models - SP280, SP380 & SP500
- Integrated filter basket
- Hi-flo motor cooling venturi
- Quick fit assembly bracket to suit specific evaporative cooler models
- Thermal overload protection (UL approved)
- Long life ball bearings
- Stainless steel shaft
- Continuous S1 duty
- Standard 240V 50 Hz
- EMC approved to AS/NZS CISPR14:2010
- Tested to AS/NZS 60335.1:2011 (Household and similar electrical appliances - Safety requirements)



PART NO.	FLOW L/m @ 600mm	FLOW L/m @ 1600mm	CURRENT	POWER
SP280	24.0	16.5	0.38A	44W
SP380	29.5	23.0	0.44A	52W
SP500	38.0	30.5	0.57A	67W





## Isolator Switches

IP66 Rated isolation switches available in both single pole and triple pole and ranging from 20-63amp.



PART NO.	DESCRIPTION
UKF4120	20A Single Pole Isolation Switch (Square)
UKF4135	35A Single Pole Isolation Switch
UKF4163	63A Single Pole Isolation Switch
UKF4220	20A Double Pole Isolation Switch (Square)
UKF4220R	20A Double Pole Isolation Switch
UKF4235	35A Double Pole Isolation Switch
UKF4263	63A Double Pole Isolation Switch
UKF4335	35A Three Pole Isolation Switch
UKF4363	63A Three Pole Isolation Switch

## Nitto Duct Tape



Innovation for Customers

PART NO.	DESCRIPTION
204EGREY	48mm x 30m Grey Nitto Duct Tape
204BLACK	48mm X 30m Black Nitto Duct Tape
204EWHITE	48mm X 30m White Nitto Duct Tape



## Foil Tapes

PART NO.	DESCRIPTION
FT48	48mm X 50m Plain Foil Tape
FT48RA	48mm X 50m Reinforced Acrylic Foil Tape
FT48RH	48mm X 50m Reinforced Hot Melt Foil Tape
FT72	72mm X 50m Plain Foil Tape
FT72RA	72mm X 50m Reinforced Acrylic Foil Tape
FT72RH	72mm X 50m Reinforced Hot Melt Foil Tape





## Nitto Electrical Tape

PART NO.	DESCRIPTION
<b>288EFR-Rainbow</b>	18mm x 20m Rainbow Flame Retardant Elec Tape (10Pk)
<b>288EFR-Black</b>	18mm x 20m Black Flame Retardant Elec Tape
<b>288EFR-Blue</b>	18mm x 20m Blue Flame Retardant Elec Tape
<b>288EFR-G/Y</b>	18mm x 20m Green / Yellow Flame Retardant Elec Tape
<b>288EFR-Red</b>	18mm x 20m Red Flame Retardant Elec Tape
<b>288EFR-White</b>	18mm x 20m White Flame Retardant Elec Tape



## Super Strap

PART NO.	DESCRIPTION
<b>DSCLIP</b>	Duct Suspension Clip (40pk)
<b>DSSADDLE</b>	Duct Suspension Saddles (100pk)
<b>DSSTRAP</b>	25mm Strap Duct Suspension x 60m Roll



## Nylon Brush

PART NO.	DESCRIPTION
<b>NB12</b>	1/2" (12.7mm) Nylon Brush Condenser Cleaner
<b>NB58</b>	5/8" (15.9mm) Nylon Brush Condenser Cleaner
<b>NB34</b>	3/4" (19.1mm) Nylon Brush Condenser Cleaner



## Tamper Evident Straps

PART NO.	DESCRIPTION
<b>TES31</b>	Tamper Evident Straps (10pk)





## Cloth Abrasive Tape

PART NO.	DESCRIPTION
119CT1203M	120 Grit Cloth Abrasive Tape 3M
119CT12050M	120 Grit Cloth Abrasive Tape 50M
119CT1803M	180 Grit Cloth Abrasive Tape 3M
119CT18050M	180 Grit Cloth Abrasive Tape 50M



## Cloth Abrasive Pad

PART NO.	DESCRIPTION
119SPMAROON	Abrasive Scour Pad 230 x 150mm





# NOTES

A series of horizontal dotted lines for taking notes.



**ASPEN  
PUMPS**  
ASIA PACIFIC

# CONTACT US

 8 Waddikee Road, Lonsdale SA 5160

 08 8186 4666

 sales@aspenspumps.com.au

 aspenspumps.com.au

## OUR LEADING BRANDS

