

MOTOR SPECIFICATION

808556MTA-A14

Q.R. No.	Y002442	CUSTOMER NO.	0550-94					
CUSTOMER	CARRIER-APAC							
MOTOR RATING	VOLTS	240	Hz	50	Ph	1	Duty	S1 A.O.M.
	MAX. INPUT	850		1.55		AMPS		
	NOM. OUTPUT	240 WATTS						
ROTATION	CLOCKWISE AT DRIVE END							
CAPACITOR	START	-----	μF/V	RUN	7.5/400 μF/V			
ENCLOSURE	TOTALLY ENCLOSE							
MOTOR TYPE	PSC		INSULATION CLASS	F				
THERMAL PROTECTION	AUTO RESET OVERLOAD							
APPLICATION	FAN CONDENSING - SHAFT HORIZONTAL / VERT. UP							
BEARING D.E.	6202 ZZ		LUBRICATION	LONG LIFE, WIDE RANGE				
BEARING N.D.E.	6202 ZZ							
SUPPLY LEAD	FLEX 1500 ±30 GREY							
EARTH PROVISION	SUPPLIED							
BASIC BUILD SPECIFICATION	305-570-44		PAINT/ COLOUR	PC GREY				
PERFORMANCE SPECIFICATION	SP85372-01							
CONNECTION DIAGRAM	CDC-018		RATING LABEL	AS SHOWN				

FINAL INSPECTED MOTORS MUST COMPLY WITH ELECTRIC MOTOR VIBRATION SPECIFICATION (ES049)

THIRD ANGLE PROJECTION

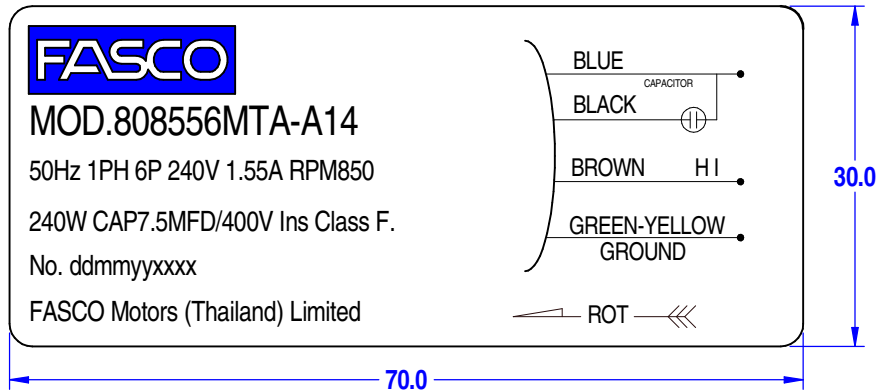
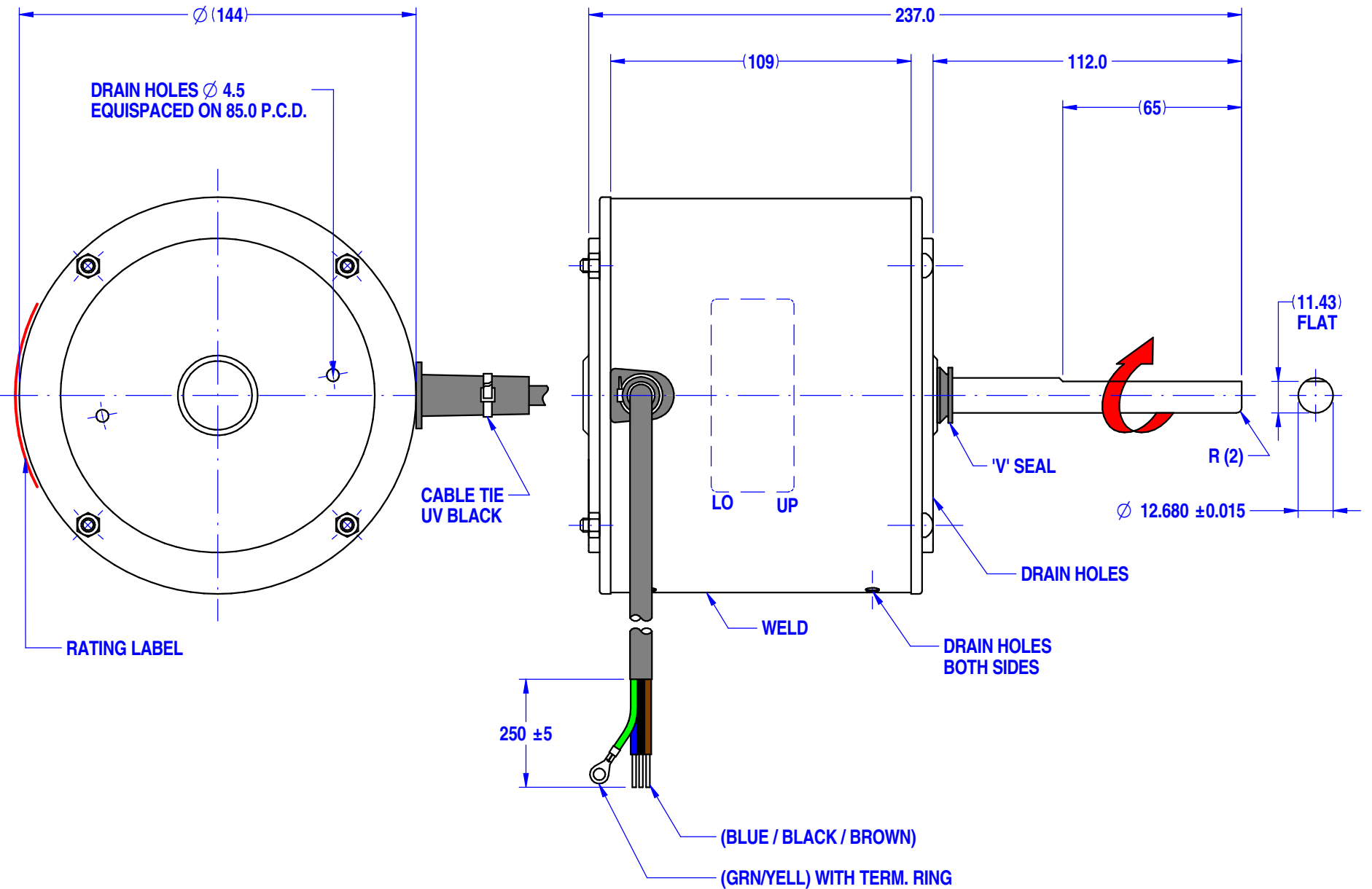

SPECIAL REQUIREMENTS:
 1)_ ENDSHIELDS MUST BE POWDER COATED.
 2)_ CAPACITOR SUPPLIED BY CUSTOMER.
 3)_ DRAIN HOLES PLUGS (4 OFF) PACKED IN PLASTIC BAG AND SUPPLIED LOOSE WITH MOTOR.

UNLESS OTHERWISE SPECIFIED : DIMENSIONS ARE IN MM. TOLERANCES		MOTOR WEIGHT	6.4 kg.
DECIMALS	ANGULAR	DRAWN	Nithad 09/05/2005
.X ± 1.0	± 30'	CHECKED	Pipat 26/02/2018
.XX ± 0.1		RELEASED	Suksakorn 26/02/2018
THIS DRAWING REMAINS THE PROPERTY OF FASCO MOTORS AND MAY NOT BE USED, COPIED OR ISSUED WITHOUT WRITTEN PERMISSION FROM FASCO MOTORS		SCALE	N.T.S.

FASCO THAILAND
 29/7-8 MOO 3, BANGKRUAY - SAINOI Rd.,
 BANGKRANG, MUANG NONTABURI DISTRICT,
 NONTABURI 11000 THAILAND

FRAME	MOTOR	
STATUS	R	
SHEET	DWG. NO.	REVISION
A3	808556MTA-A14	B

MIC1707429
 By: Muntana
 Date: 08/01/2018
 MIC B: Back previous to Rev. A (REGISTER WRONG)