

POSH

SOLUS MKII 5 FUNCTION HI-RISE SHOWER

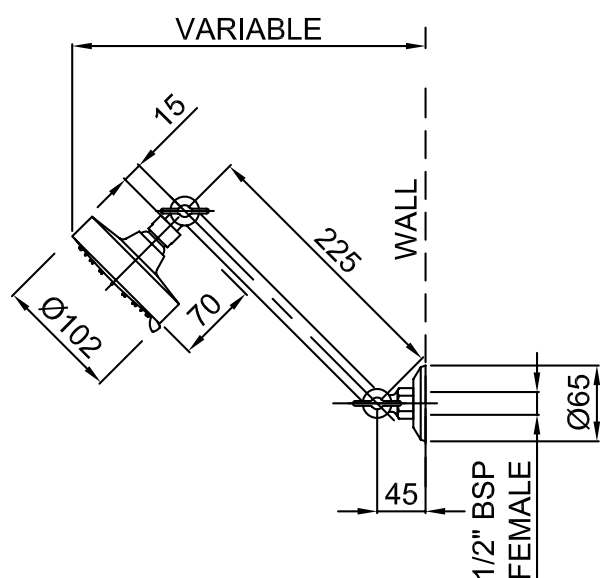

SPECIFICATIONS

Recommended use	Domestic, hotel and commercial
Colour availability	Chrome
Pressure rating	Suitable for high pressure applications and has been WELS certified to the following: Minimum operating pressure 1.5 bar (150kPa) Minimum operating pressure 5 bar (500kPa)
Temperature rating	Maximum hot temperature 60°C (recommended 42°C) Minimum temperature 1°C
WELS	Stars: 3 Flow rate: 9L p/min
Standards	AS 3662:2005 Level 2

CLEANING RECOMMENDATIONS

This product should not be cleaned with abrasive materials eg. steel wool/scourers. Do not use any corrosive or abrasive cleaning agents containing acids or scouring agents. Bleaches can also discolour products and therefore should not be used. Damage caused by any improper treatment is not covered by the product warranty – refer to Warranty Conditions on the last page.



To see the complete Posh range go to www.reece.com.au/bathrooms



Disclaimer: Products in this specification manual must by regulation be installed by licensed and registered trade people. The manufacturer/distributor reserves the right to vary specifications or delete models from their range without prior notification. Dimensions and set-outs listed are correct at time of publication however the manufacturer/distributor takes no responsibility for printing errors.

Tech Page Version 2

Posh

reece

POSH

SOLUS MKII 5 FUNCTION HI-RISE SHOWER

INSTALLATION INSTRUCTIONS

IMPORTANT

Please Note:

1. Some showers may not provide an effective shower when used with gravity fed heated water systems or where pressures are less than 150kPa at the outlet. Additionally showers with flow rates of less than 9L/min may not allow the following to function correctly:
 - some instantaneous water heaters
 - some tempering valves
 - some thermostatic mixing valves
2. Some shower heads only operate correctly when hot and cold water supplies are both mains pressure and may not be suitable for some instantaneous hot water services.

INSTALLATION

The tools you will need: adjustable spanner.

1. Unscrew your old shower anti-clockwise.
2. Clean the exposed thread and bind clockwise with thread sealing tape.
3. All pipework must be thoroughly flushed prior to the installation of the shower.
4. Screw on your new shower (clockwise).

POSH

SOLUS MKII 5 FUNCTION HI-RISE SHOWER



REECE PRODUCT QUALITY GUARANTEE

You have purchased a quality product from Reece Pty Ltd ABN 84 004 097 090 ("Reece"). This product is covered by a 10 year replacement product warranty, including any spare parts, and a 12 month warranty over labour.

10 YEAR WARRANTY – DOMESTIC USE

This warranty covers faults in the product construction, material and assembly. Products which are within 10 years from the date of purchase, found upon inspection by an authorised Reece representative, to be defective in construction, material or assembly, will be repaired or exchanged with an equivalent product free of charge. Replaced items become Reece's property.

All replacement products will be available for collection without charge to the customer at the nearest Reece branch to the customer's location, or elsewhere as agreed between the customer and Reece.

Labour and Spare Parts

The labour for the replacement of products and spare parts to which this warranty applies will be supplied by Reece or relevant supplier using licensed plumbers engaged by Reece or relevant supplier within 1 year from the date of purchase.

Spare parts which are within 10 years from the date of purchase found upon inspection by an authorised Reece representative to be defective in construction, material or assembly, will be replaced free of charge.

Warranty Conditions

This warranty will apply only under all of the following conditions:

- The item has been installed by a licensed plumber
- The item has been installed for and subjected to domestic residential use only
- Failure is due to a fault in the manufacture of the product
- Proof of purchase (including the date of purchase) is provided
- The installation of the product is in accordance with the instructions provided
- This warranty does not cover products purchased as an ex-display without being fully checked and tested for sale by the manufacturer.

This warranty does not include faults caused by:

- Unsuitable or improper use
- Incorrect installation or installation not in accordance with the instructions provided
- Installation or part installation by the purchaser or any person other than a LICENSED PLUMBER
- Normal wear and tear
- Inadequate or complete lack of maintenance
- Chemical, electrochemical or electrical influences
- Harsh detergents or abrasive cleaners used on product finishes

1 YEAR WARRANTY – COMMERCIAL USE

'Commercial' use is all use other than for normal domestic residential purposes, including use in non-business places as in public buildings, schools, sports centres and in establishments that contain private bathrooms with high frequency of use by many individuals, such as hotels, motels, retirement villages and hospitals.

The Commercial warranty covers this product against manufacturing faults in the construction, material and assembly of both the finished products and any spare parts for a period of 1 year from the date of purchase. Products and spare parts which are found upon inspection by an authorised Reece representative to be defective in construction, material or assembly will be repaired or exchanged free of charge. Replaced items become Reece's property. The labour for the replacement of products and spare parts to which this warranty applies will be supplied by Reece or relevant supplier using licensed plumbers engaged by Reece or relevant supplier. The Warranty Conditions and exclusions which apply to the domestic use warranty also apply to this commercial warranty.

EXCLUSIONS

To the fullest extent permitted by law, Reece excludes all liability for damage or injury to any person, damage to any property, and any indirect consequential or other loss or damage.

CLAIM PROCEDURE

For all warranty queries customers are to contact the branch where the product was purchased. These details can be found on your purchase invoice.

Our goods come with guarantees that cannot be excluded under the Australian Consumer Law. You are entitled to a replacement or refund for a major failure and for compensation for any other reasonably foreseeable loss or damage. You are also entitled to have the goods repaired or replaced if the goods fail to be of acceptable quality and the failure does not amount to a major failure.

POSH SOLUS WALL TOP ASSEMBLIES

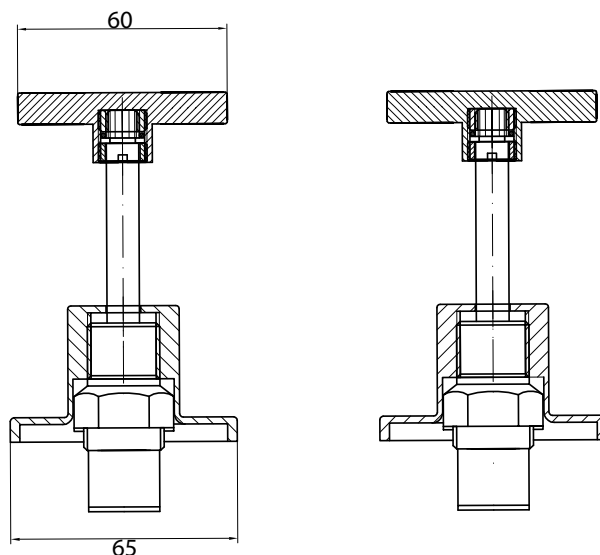

Dimensions are nominal measurements only.

SPECIFICATIONS

Recommended use	Domestic, hotel and commercial.
Colour	Chrome
Pressure Rating	Maximum continuous operating pressure 1000kPa. For best performance and longer life we recommend 150-500kPa as per AS/NZS3500
Temperature Rating	Maximum continuous working temperature 80°
Suitable Hot Water Units	Storage Tank: Yes Continuous Flow: Yes Gravity Feed: Yes



To see the complete Posh range go to www.reece.com.au/bathrooms

CLEANING RECOMMENDATIONS

We recommend the use of soapy water or approved cleaners.

This product should not be cleaned with abrasive materials.

Damage caused by any improper treatment is not covered by the product warranty- refer to Warranty Conditions.

POSH

SOLUS WALL TOP ASSEMBLIES

Important Note

Tapware must be installed to the requirements of AS/NZS 3500 by a qualified plumber. Please ensure all pipework is thoroughly flushed out prior to installation.

INSTALLATION

1. Fully open tap spindle, ensure fibre washer and jumper valve are in position.
2. Screw spindle and stuffing box into recess tap body by hand and tighten with suitable tube spanner.
3. Place flange over spindle and stuffing box and tighten firmly by hand.
4. Fit handle assembly as follows:-
 - i) Turn both spindles to the fully off position.
 - ii) Place the handle retaining nut over the spindle with the slot facing the wall.
 - iii) Place the handle retaining clip into the groove at the bottom of the spline of the spindle.
 - iv) Fit handle to spindle and position to suit. Push the handle down firmly until it bottoms internally.
 - v) Screw retaining nut into the handle and tighten using the spanner provided.

NOTE: Adaptors provided may be required for extension of spindle where recess of body is beyond plaster or tile

POSH

SOLUS WALL TOP ASSEMBLIES



REECE PRODUCT QUALITY GUARANTEE

You have purchased a quality product from Reece Pty Ltd ABN 84 004 097 090 ("Reece"). This product is covered by a 7 year replacement product warranty and a 12 month warranty over spare parts and labour.

7 YEAR WARRANTY – DOMESTIC USE

This warranty covers faults in the product construction, material and assembly. Products which are within 7 years from the date of purchase, found upon inspection by an authorised Reece representative, to be defective in construction, material or assembly, will be repaired or exchanged with an equivalent product free of charge. Replaced items become Reece's property. This warranty also covers any spare parts included under "Manufacturer's Provisions" below.

All replacement products will be available for collection without charge to the customer at the nearest Reece branch to the customer's location, or elsewhere as agreed between the customer and Reece.

Manufacturer's Provisions

The following spare parts are covered by a 7 year warranty:

- Cartridges

Labour and Spare Parts

The labour for the replacement of products and spare parts to which this warranty applies will be supplied by Reece or relevant supplier using licensed plumbers engaged by Reece or relevant supplier within 1 year from the date of purchase.

Spare parts other than those listed in the Manufacturer's Provisions above, which are within 1 year from the date of purchase found upon inspection by an authorised Reece representative to be defective in construction, material or assembly, will be replaced free of charge.

Warranty Conditions

This warranty will apply only under all of the following conditions:

- The item has been installed by a licensed plumber
- The item has been installed for and subjected to domestic residential use only
- Failure is due to a fault in the manufacture of the product
- Proof of purchase (including the date of purchase) is provided
- The installation of the product is in accordance with the instructions provided

This warranty does not cover products purchased as an ex-display without being fully checked and tested for sale by the manufacturer.

This warranty does not include faults caused by:

- Unsuitable or improper use
- Incorrect installation or installation not in accordance with the instructions provided
- Installation or part installation by the purchaser or any person other than a LICENSED PLUMBER
- Normal wear and tear
- Inadequate or complete lack of maintenance
- Chemical, electrochemical or electrical influences
- Harsh detergents or abrasive cleaners used on product finishes

1 YEAR WARRANTY – COMMERCIAL USE

'Commercial' use is all use other than for normal domestic residential purposes, including use in non-business places as in public buildings, schools, sports centres and in establishments that contain private bathrooms with high frequency of use by many individuals, such as hotels, motels, retirement villages and hospitals.

The Commercial warranty covers this product against manufacturing faults in the construction, material and assembly of both the finished products and any spare parts for a period of 1 year from the date of purchase. Products and spare parts which are found upon inspection by an authorised Reece representative to be defective in construction, material or assembly will be repaired or exchanged free of charge. Replaced items become Reece's property. The labour for the replacement of products and spare parts to which this warranty applies will be supplied by Reece or relevant supplier using licensed plumbers engaged by Reece or relevant supplier. The Warranty Conditions and exclusions which apply to the domestic use warranty also apply to this commercial warranty.

EXCLUSIONS

To the fullest extent permitted by law, Reece excludes all liability for damage or injury to any person, damage to any property, and any indirect consequential or other loss or damage.

CLAIM PROCEDURE

For all warranty queries customers are to contact the branch where the product was purchased. These details can be found on your purchase invoice.

Our goods come with guarantees that cannot be excluded under the Australian Consumer Law. You are entitled to a replacement or refund for a major failure and for compensation for any other reasonably foreseeable loss or damage. You are also entitled to have the goods repaired or replaced if the goods fail to be of acceptable quality and the failure does not amount to a major failure.