

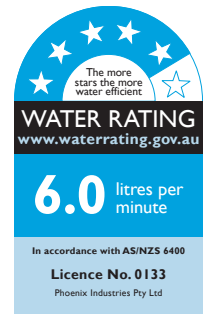

**Phoenix Pristine 2-in-1 Filtered Water Sink Mixer Tap with Filter Chrome Plated (5 Star)**

2302995

SPECIFICATIONS	
Recommended Use	Domestic;Hotel;Commercial
Colour Finish	Polished Chrome
Primary Material	DR Brass
Recommended Pressure Range	150 - 500 kPa as per AS3500
Max Continuous Working Temperature (deg C)	75
Min Continuous Working Temperature (deg C)	5
Hot Water Unit Suitability	Storage Tank;Continuous Flow
WARRANTY	
Warranty - Domestic Use (Years)	7
Spare Parts & Labour (Years)	1
<i>Please refer to Warranty Page for full Terms and Conditions</i>	

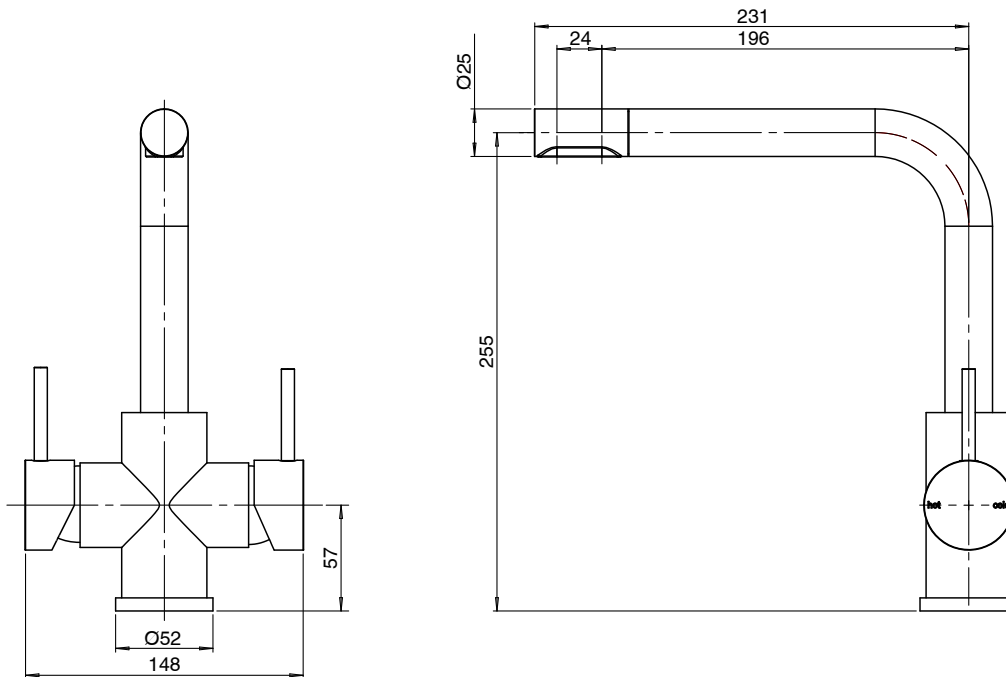

Dimensions are nominal measurements only.

**CLEANING RECOMMENDATIONS:**

We recommend the use of soapy water or approved cleaners. This product should not be cleaned with abrasive materials. Damage caused by any improper treatment is not covered by the product warranty. Refer to Warranty Conditions

**Disclaimer:** Products in this specification manual must by regulation be installed by licensed and registered trade people. The manufacturer/distributor reserves the right to vary specifications or delete models from their range without prior notification. Dimensions are nominal measurements only. Dimensions and set-outs listed are correct at time of publication however the manufacturer/distributor takes no responsibility for printing errors.

Published 31/03/2025

To see the complete Phoenix range go to [www.reece.com.au](http://www.reece.com.au)

