

Model D-TDW-A

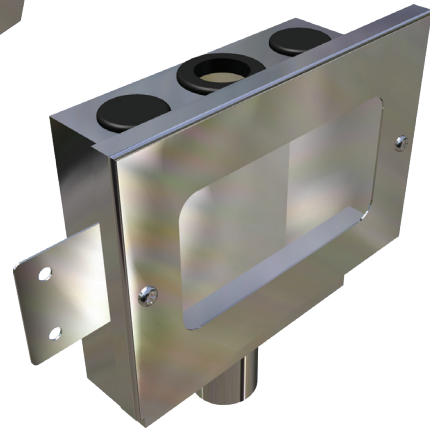

Model D-TDW-B



features and benefits

- Standard and custom sizes available
- Removable inspection window
- Purpose built to suit your specific application
- Quality components for durability
- Manufactured from grade 304 or 316 stainless steel

about

The *BRITEX In Wall Tundish* is manufactured from 1.2mm satin finish stainless steel and comes complete with a removable inspection window allowing for visibility to detect blockages and ensure ease of cleaning. It is primarily used as a discharge point in refrigeration and air conditioning wastes for conditioning wastes for condensation and waste water. The In Wall Tundish is commonly used in hospitals, apartment buildings, medical centres and aged care facilities.

sample spec. text

BRITEX 1.2 grade 304 S.S. In Wall Tundish - 190mm wide x 130mm high x 68mm deep supplied complete with removable inspection window and 40mm BSP connection - Product Code D-TDW

*RED TEXT may denote a **variable** where one option only is to be selected, a **nominal dimension** that needs to be specified, or an **optional feature** that can be removed if not required. Please refer to the back of this page for additional specification details and options.

VISIT BRITEX.COM.AU TO DOWNLOAD BIM FILES, CAD DRAWINGS AND THE MOST CURRENT PRODUCT LITERATURE.



MELBOURNE
Britex Place, Mirra Crt
Bundoora VIC 3083
t (03) 9466 9000
f (03) 9466 9044

SYDNEY
16 Northumberland Drv
Taren Point NSW 2229
t (02) 9531 2100
f (02) 9531 2800

PERTH
Unit 1/8 Principal Link
Malaga WA 6090
t (08) 9249 5464
f (08) 9248 6893

BRISBANE
19 Manilla St
East Brisbane QLD 4169
t (07) 3363 2400
f (07) 3363 2444

ADELAIDE
The Britex Group
SA State Office
t 1300 764 744
f 1300 784 306

IN WALL TUNDISH

PRODUCT CODE

D-TDW-A D-TDW-B

5.12

TANKS & DRAINAGE

#D-TDW / IN WALL TUNDISH

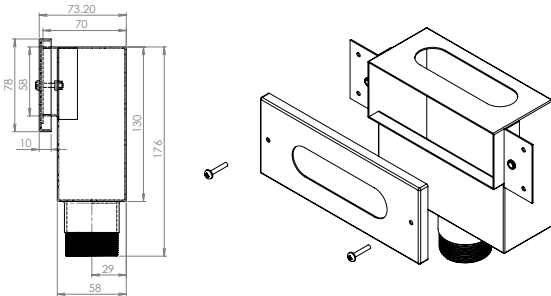

MODEL D-TDW-A Side Elevation and Isometric View

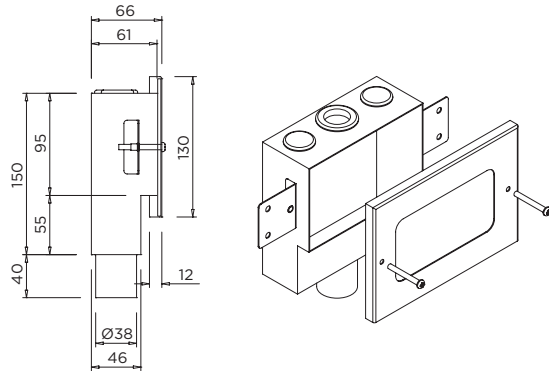

MODEL D-TDW-B Side Elevation and Isometric View

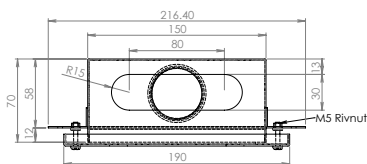

MODEL D-TDW-A Plan

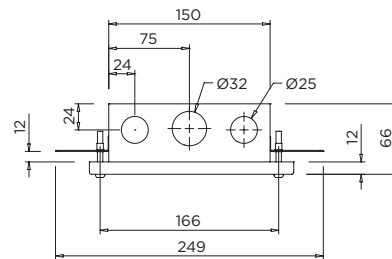

MODEL D-TDW-B Plan

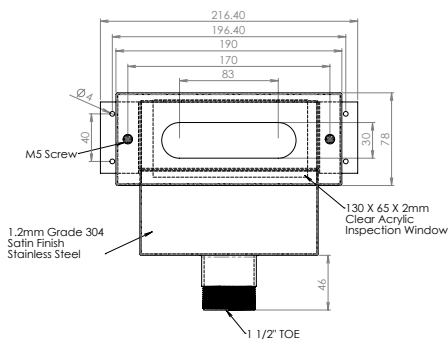

MODEL D-TDW-A Front Elevation

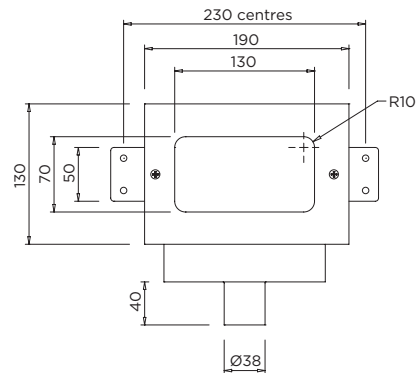

MODEL D-TDW-B Front Elevation

specifying guide

When specifying this product please include:

- Product Name and Code
- Product Dimensions
- Product Features
- Grade of Stainless Steel

options

- Grade 304 or 316 S.S.
- Custom dimensions
- Custom designs - contact BRITEX

VISIT BRITEX.COM.AU TO DOWNLOAD BIM FILES, CAD DRAWINGS AND THE MOST CURRENT PRODUCT LITERATURE.

Last Revised June 2017