



Grate Seal Bucket Trap

GSBT

Grate Seal Bucket Trap 100mm (with basket)



Product Standards and Certifications



WaterMark

WMTS-044

Certificate No. 23002

| | |
|--------------|--------------------|
| Product Code | GSBT |
| Material | Polyurethane/Nylon |
| Flow Rate | 45L/min |
| Standards | WMTS-044:2022 |

Grate Seal® Bucket Trap is designed to catch debris and is the most cost-effective commercial grade bucket trap on the market and has the simplest installation of its kind.

The Grate Seal® Bucket Trap does not prevent the operation of a fire collar, unlike stainless steel varieties, it is constructed of an elastomeric & polymer material which a fire collar can crush and provide the necessary fire barrier. The finished floor surface, tile, resin, vinyl or any other material is not disturbed due to the Grate Seal® Bucket Trap being a separate item from the outlet, being made from a flexible material and installed in the drainage riser pipe.



Permanent, cost effective solution



Install and uninstall in minutes

- Suits 100mm outlets as it is installed under the grate
- Unlike SS varieties, the bucket trap does not prevent the operation of a fire collar
- The materials used are resistant to breaking down
- Easy, retrofit installation in just a few minutes
- No alterations to existing outlets
- No fixing required as the seal stays in place through friction
- Bucket is easily removed for maintenance
- Basket can be easily removed for emptying



GSBT Line Drawing

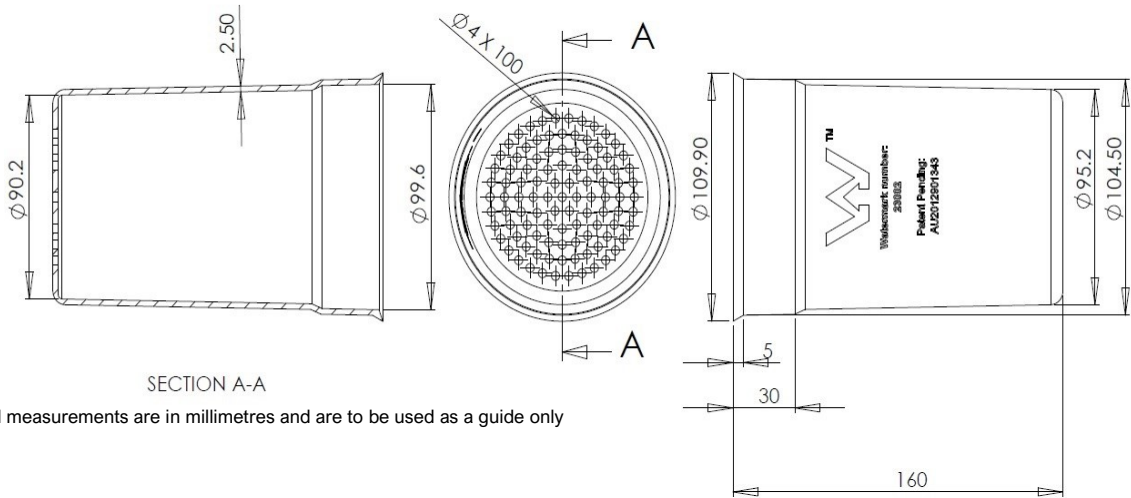

Additional Information

Installation Instructions

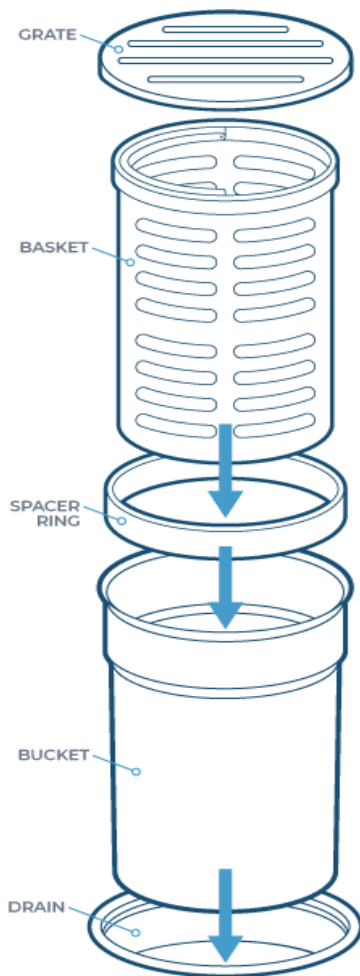

Installation

- Remove the grate and if necessary clean grime from the top of the riser pipe. **1**
- Squeeze and fold the Bucket and insert below the grate housing. Release and massage to fit snugly against the pipe wall. **2**
- Using long nose pliers, fold and insert the applicable Spacer Ring into the rebate at the top of the Bucket. **3**
- Insert the Basket and replace the grate. (Note: remove and empty/clean the basket periodically or as required). **4**

Note: A) This device is intended to prevent debris from entering the drainage system. B) The product should not be removed from the packaging until it is to be installed. C) The product shall not be installed into an overflow relief gully (ORG). D) Install clear of the following potential obstructions: (i) an existing water level within a trap, (ii) any inlets to a riser, and (iii) any above ground soil, waste and drainage pipe collars. E) Product warranty details including contact details for warranty claims are available from the contact information below. F) Installation to be undertaken by a licensed practitioner or competent person. G) Do not allow the Grate Seal products to come into contact with harsh or abrasive chemicals or cleaning agents as this may affect the integrity and the lifespan of the rubber compound. H) Warranty period is 1 year for defective products only. General wear and tear or misuse of product will not be covered under warranty.