

# ARMITAGE SHANKS

## PORTMAN21 RIMLESS BACK TO WALL OVERHEIGHT PAN

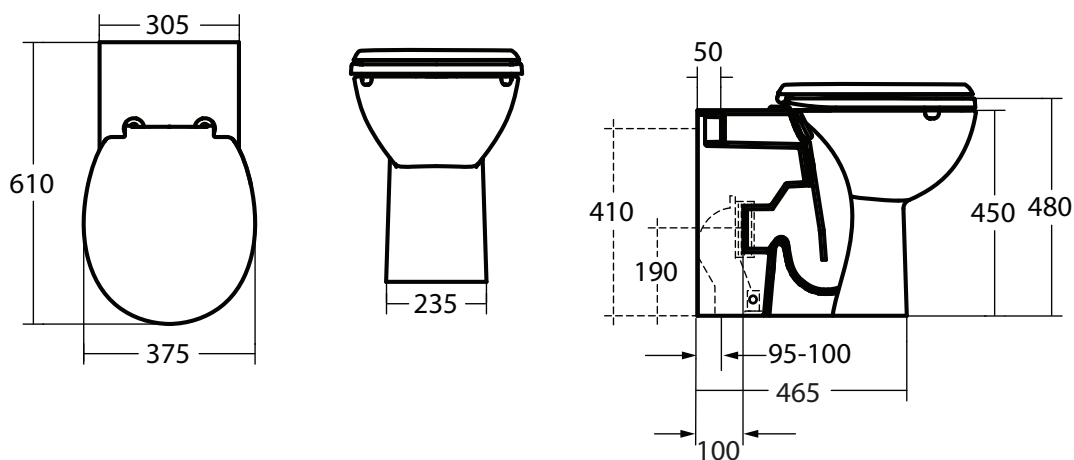

Dimensions are nominal measurements only.

### SPECIFICATIONS

<b>Recommended Use</b>	Domestic, Hotel and Commercial
<b>Material</b>	Pan: Vitreous China Seat: Plastic
<b>Colour</b>	Pan: White Double Flap Seat: White Single Flap Seat: White, Steel Blue or Grey
<b>Weight</b>	34kg
<b>Rim Configuration</b>	Rimless
<b>Bowl Configuration</b>	P Trap (Converts to S using plastic S-bend provided)
<b>Set Out</b>	P Trap: 190mm, S Trap: 95mm - 100mm
<b>Pan Fixing</b>	Screwed to floor using brackets (supplied) and bedded with sealant



To see the complete ARMITAGE SHANKS range go to [www.reece.com.au/bathrooms](http://www.reece.com.au/bathrooms)

### CLEANING RECOMMENDATIONS

We recommend the use of soapy water or approved cleaners.

This product should not be cleaned with abrasive materials.

Damage caused by any improper treatment is not covered by the product warranty. Refer to Warranty Conditions.

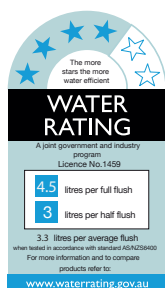

**Disclaimer:** Products in this specification manual must by regulation be installed by licensed and registered trade people. The manufacturer/distributor reserves the right to vary specifications or delete models from their range without prior notification. Dimensions are nominal measurements only and set-outs listed are correct at time of publication however the manufacturer/distributor takes no responsibility for printing errors.

Tech Page Version 1

Armitage  
Shanks

reece

# ARMITAGE SHANKS PORTMAN21 RIMLESS BACK TO WALL OVERHEIGHT PAN

## INSTALLATION INSTRUCTIONS

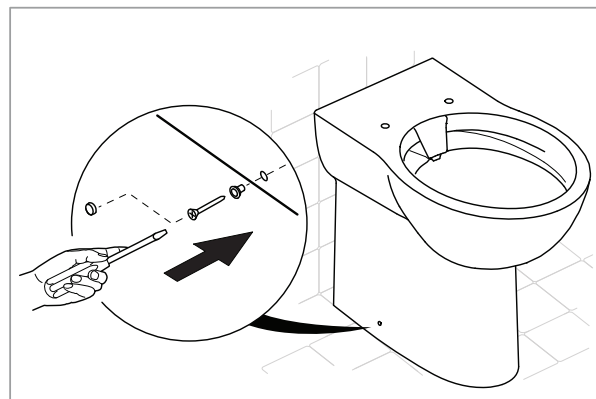
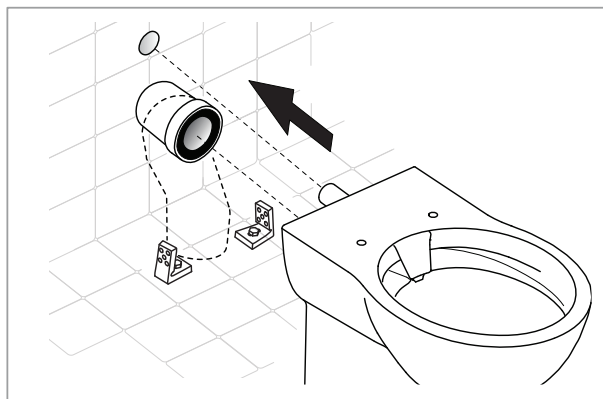
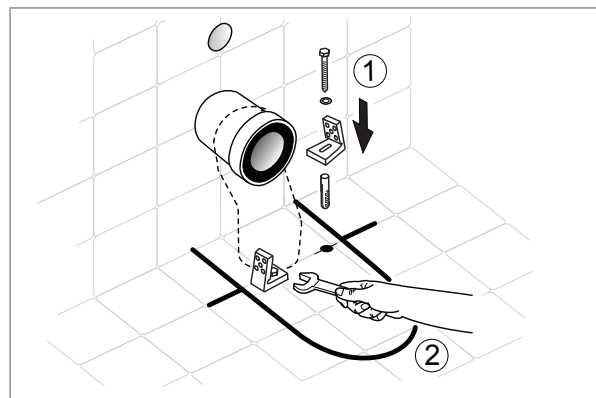
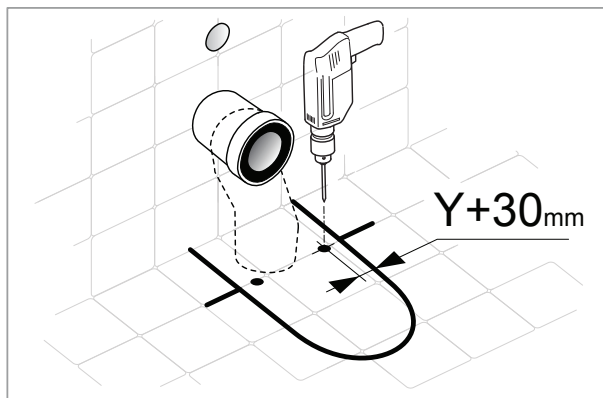
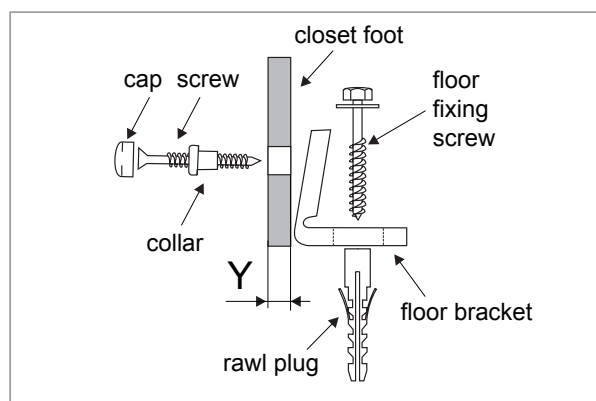
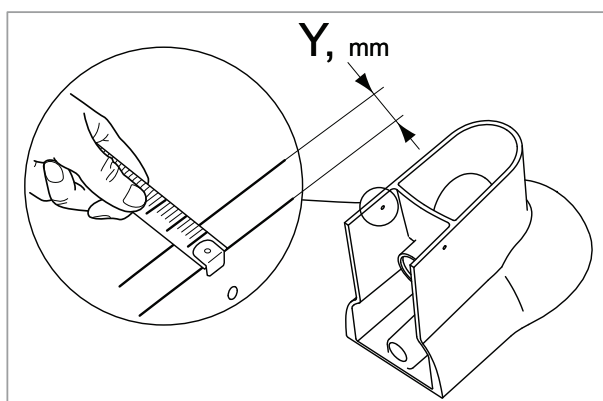
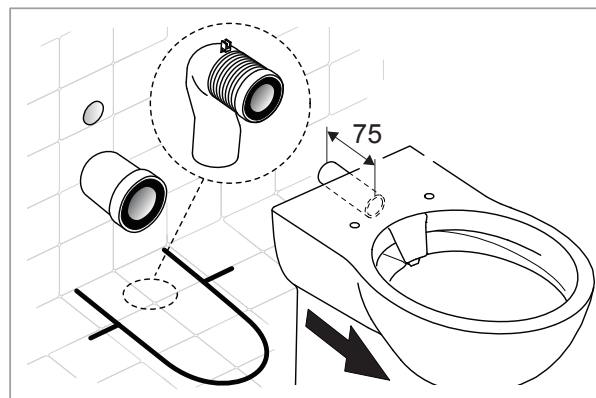
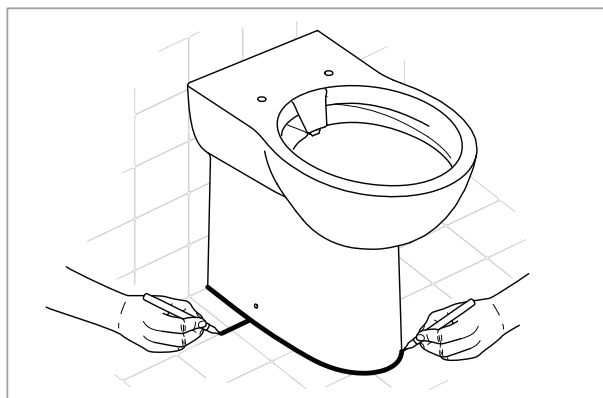

The installation of the toilet suite shall be in accordance with the normal minimum drainline grade requirements in AS/NZS 3500.2

Plumbers, please ensure a copy of the installation instructions is left with the end user for future reference

# ARMITAGE SHANKS PORTMAN21 RIMLESS BACK TO WALL OVERHEIGHT PAN

SEAT INSTALLATION INSTRUCTIONS

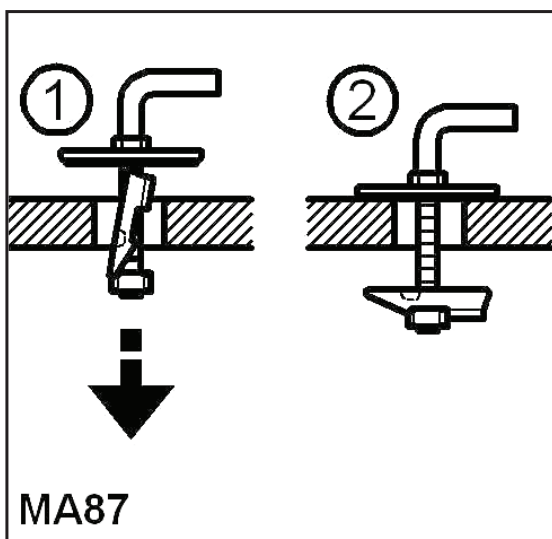
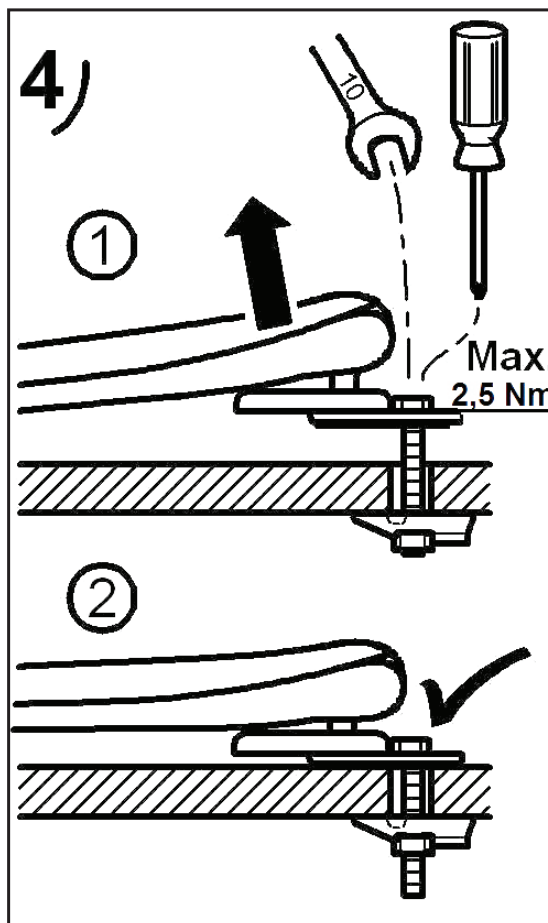
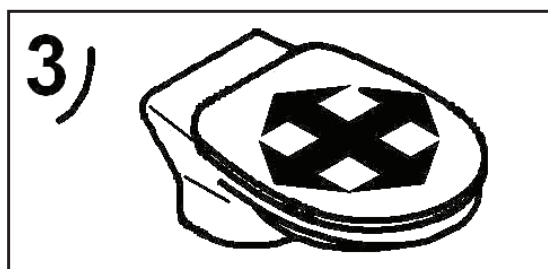
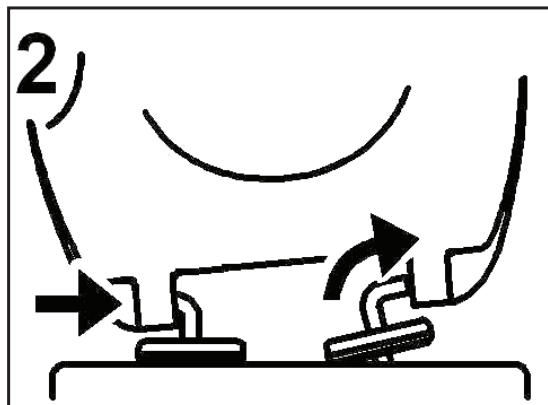
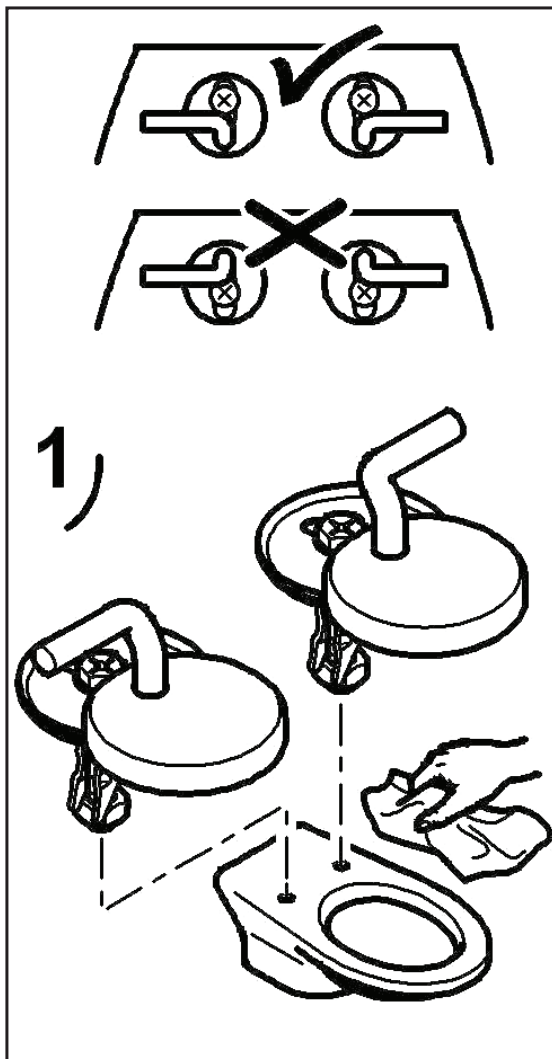

Plumbers, please ensure a copy of the installation instructions is left with the end user for future reference



## REECE PRODUCT QUALITY GUARANTEE

You have purchased a product from Reece Australia Pty Ltd ABN 84 004 097 090 ("Reece"). This product is covered by a 25 year replacement product warranty and a 12 month warranty over spare parts and labour.

### 25 YEAR PRODUCT WARRANTY

This warranty covers faults in the construction, material and assembly of finished products. Products which are within 25 years from the date of purchase, found upon inspection by an authorised Reece representative to be defective in construction, material or assembly, will be repaired or exchanged with an equivalent product free of charge. Replaced items become Reece's property.

### ONE YEAR SPARE PARTS WARRANTY

Spare parts (includes the toilet seat) which are within 1 year from the date of purchase found upon inspection by an authorised Reece representative to be defective in construction, material or assembly will be replaced free of charge. Replaced items become Reece's property.

### AVAILABILITY OF REPLACEMENT PRODUCTS AND SPARE PARTS

All replacement products and spare parts will be available for collection without charge to the customer at the nearest Reece branch to the customer's location, or elsewhere as agreed between the customer and Reece.

### LABOUR

The labour for the replacement of products that are within one year from the date of purchase found upon inspection by an authorised Reece representative to be defective in construction, material or assembly, and in relation to all spare parts to which this warranty applies, will be supplied by Reece or the relevant supplier using licensed plumbers engaged by Reece or the relevant supplier

### WARRANTY CONDITIONS

This warranty will apply only under all of the following conditions:

- The item has been installed by a licensed plumber
- Failure is due to a fault in the manufacture of the product
- Proof of purchase (including the date of purchase) is provided
- The installation of the product is in accordance with the instructions provided
- The product has been installed in valid applications as stated in accordance with the recommended use

This warranty does not cover products purchased as an ex-display without being fully checked and tested for sale by the manufacturer.

This warranty does not include faults caused by:

- Unsuitable or improper use
- Incorrect installation or installation not in accordance with the instructions provided
- Installation or part installation by any person other than a LICENSED PLUMBER who is suitably qualified to install the product, or a Licensed Electrician where applicable.
- Normal wear and tear
- Inadequate or complete lack of maintenance
- Chemical, electrochemical or electrical influences
- Harsh detergents or abrasive cleaners used on product finishes

### EXCLUSIONS

To the fullest extent permitted by law, Reece excludes all liability for damage or injury to any person, damage to any property, and any indirect consequential or other loss or damage.

### CLAIM PROCEDURE

For all warranty queries customers are to contact the branch where the product was purchased. These details can be found on your purchase invoice.

General contact details for Reece are as follows:

Reece Australia Pty Ltd  
118 Burwood Hwy  
Burwood VIC 3125  
+61 3 9274 0000  
admin@reece.com.au

The benefits given by this warranty are in addition to the other rights and remedies that consumers may have under the Australian Consumer Law and any other applicable laws.

Our goods come with guarantees that cannot be excluded under the Australian Consumer Law. You are entitled to a replacement or refund for a major failure and for compensation for any other reasonably foreseeable loss or damage. You are also entitled to have the goods repaired or replaced if the goods fail to be of acceptable quality and the failure does not amount to a major failure.