

BRIDGLAND CHANNEL

SPECIFICATIONS

Recommended use	Universal rail suitable for all medium to heavy rail applications
Reece Product Code/Description	9503055 - B/LAND CHANNEL HDG 41x21 SLOT 6M 9503054 - B/LAND CHANNEL HDG 41x41 SLOT 6M
Material	Hot dip galvanised steel
Length	6m
Load	Please refer to Loading Table overleaf



CHANNEL DIMENSIONS [PRODUCT CODE: 9503055]

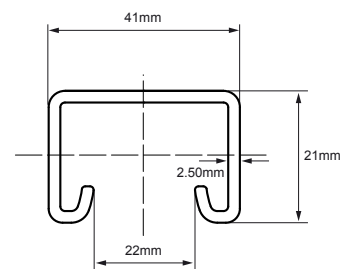
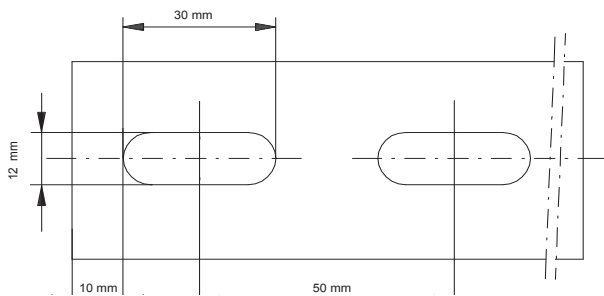

CHANNEL DIMENSIONS [PRODUCT CODE: 9503054]

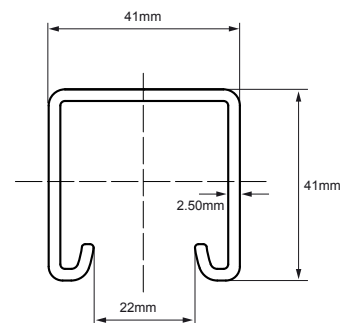
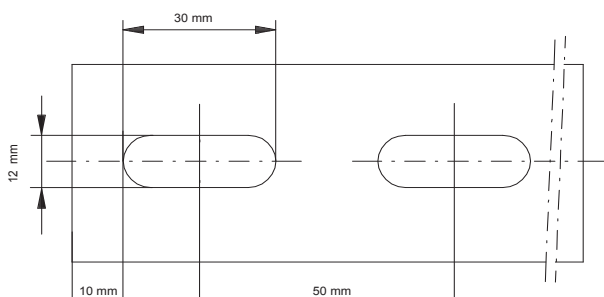

WARRANTY

You have purchased a quality product from Reece Australia. This product is covered by a 12 month warranty. This warranty covers faults in the product construction, material and assembly. Faulty products will be repaired or exchanged free of charge. Faulty items become our property.

This warranty does not include faults caused by

- Unsuitable or improper use
- Incorrect installation
- Normal wear and tear
- Inadequate or complete lack of maintenance
- Chemical, electrochemical or electrical influences

To the maximum extent permitted by law, Reece excludes all warranties other than those set out above. In the event of a warranty claim, we will replace or repair defective products, or pay for the cost of having defective products repaired or replaced, but will not be liable for any injury to any person, damage to any property, any indirect or consequential loss, or in any other respect.

Disclaimer:

Products in this specification manual must by regulation be installed by licensed and registered trade people. The manufacturer/distributor reserves the right to vary specifications or delete models from their range without prior notification. Dimensions and set-outs listed are correct at time of publication however the manufacturer/distributor takes no responsibility for printing errors.



BRIDGLAND CHANNEL

Loads are calculated taking into consideration a maximum deflection (f) of length $1/200 \times L$ and a maximum bending stress of 160 N/mm^2

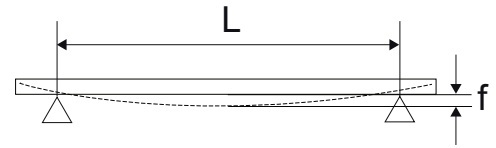

LOADING TABLE - max. allowed load in kg

L (mm)	Suspension on 1 point		2 equal loads		3 equal loads		Uniformly distributed load	
	41x21 2.5	41x41 2.5	41x21 2.5	41x41 2.5	41x21 2.5	41x41 2.5	41x21 2.5	41x41 2.5
250	243	776	182	582	121	388	486	1153
300	202	647	152	485	101	317	314	1294
350	174	555	130	416	87	277	269	1109
400	152	485	114	364	76	243	236	970
450	135	431	102	323	67	216	210	863
500	121	388	91	291	61	194	189	776
600	101	323	76	243	51	162	157	647
700	87	277	56	208	40	139	119	555
800	73	243	43	182	31	121	117	485
900	58	216	34	162	24	108	93	431
1000	47	194	28	146	20	97	75	388
1200	33	162	19	119	14	81	52	323
1400	24	139	14	87	10	63	38	238
1600	18	114	11	67	8	48	29	182
1800	14	90	9	53	6	38	23	144
2000	12	73	7	43	5	31	19	116
2250	9	58	5	34	4	24	15	92
2500	8	47	4	27	3	20	12	75
2750	6	38	4	23	3	16	10	62
3000	5	32	3	19	2	14	8	52
3250	5	28	3	16	2	12	7	44
3500	4	24	2	14	2	10	6	38
3750	3	21	2	12	1	9	5	33
4000	3	18	2	11	1	8	5	29
4250	3	16	2	10	1	7	4	26
4500	2	14	1	24	-	6	4	23
4750	2	13	1	22	-	5	3	21
5000	2	12	1	20	-	5	3	19
5250	2	11	-	18	-	5	3	17
5500	2	10	-	16	-	4	3	15
5750	1	9	-	15	-	4	2	14
6000	1	8	-	14	-	3	2	13

Disclaimer:

Products in this specification manual must by regulation be installed by licensed and registered trade people. The manufacturer/distributor reserves the right to vary specifications or delete models from their range without prior notification. Dimensions and set-outs listed are correct at time of publication however the manufacturer/distributor takes no responsibility for printing errors.

