



WOLFEN™

INSTALLATION MANUAL

9508846 Wolfen 800 Back to Wall Pan White (4*)





WOLFEN™

CONTENTS

Intro	02
Technical Information	03
Installation Instructions	04 - 05
Cleaning	05
Warranty	06

Delivering unrivalled quality

Designed for absolute performance, Wolfen's 800 Back to Wall Pan sets new standards in quality, hygiene and flushing performance. A Rimless, raised height design combined with precision engineering and extended footprint ensures suitability for care and ambulant environments.

Available in blue, grey and white single flap seats, and fixed arm back-rest (sold separately) to meet the requirements of AS1428.

TECHNICAL INFORMATION

Model	Wolfen 800 back to Wall Pan White (4*)
Product Code	9508846
Material	Pan - Vitreous China Cistern - Vitreous China Seat - Urea
Colour	Pan - White Seat - White
Weight	Pan 50kg Seat 1.1kg
Water Inlet Position	Back Inlet
Toilet Seat	Single Flap Seat
Rim Configuration	Rimless
Set Out (mm)	190 min - 290 max
Inlet Valve Pressure	500 kPa
Spare Parts	9508007 Wolfen 800 Single Flap Seat White 9508008 Wolfen 800 Single Flap Seat Blue 9508009 Wolfen 800 Single Flap Seat Grey
	9508717 Wolfen Seat Buffers (Sideways)
	9508718 Wolfen Fixing Kit
	9507171 Wolfen Back Rest with Fixed Armst

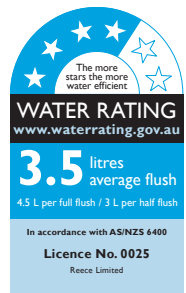

INSTALLATION INSTRUCTIONS

Wolfen 800 Back to Wall Pan White (4*)

9508846

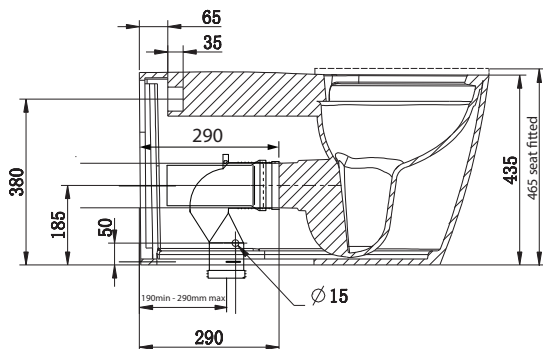

Note: All measurements should be taken from the finished wall/floor

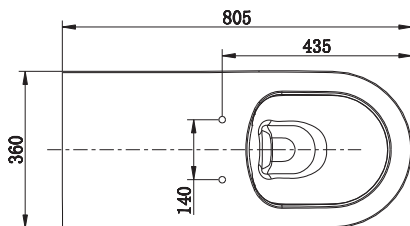

Set-Up

1. Rough in positions of water inlet pipe, waste outlet and fixing bracket holes. Ensure inlet connection extends 100mm from finished wall.
2. Prepare waste outlet according to required set out (190mm min - 290mm max) and drill floor fixing brackets into position (60mm inside traced mark of pan rim).

S-Trap Installation

1. Lubricate the rubber fins of the pan bend and position the waste pipe at the required height. Fix the pan connector back to the wall using the rod and bracket.
2. Lift pan over floor fixing brackets and push pan back to wall. Ensure you make a firm connection with inlet pipe and connect pan spigot into waste bend firmly. Flush test and check for leaks
3. Ensure that pan is level. Fix pan to floor using fixing screws and flexible sealant. Install single flap seat

CLEANING

We recommend the use of soap water or approved cleaners. This product should not be cleaned with abrasive materials. Damage caused by any improper treatment is not covered by the product warranty. Refer to Warranty Conditions.

REECE PRODUCT QUALITY GUARANTEE



You have purchased a quality product from Reece Australia Pty Ltd ABN 84 004 097 090 ("Reece"). This product is covered by a 10 year replacement product warranty and a 12 month warranty over spare parts and labour.

5 YEAR WARRANTY

This warranty covers faults in the product construction, material and assembly. Products which are within 5 years from the date of purchase, found upon inspection by an authorised Reece representative, to be defective in construction, material or assembly, will be repaired or exchanged with an equivalent product free of charge. Replaced items become Reece's property.

All replacement products will be available for collection without charge to the customer at the nearest Reece branch to the customer's location, or elsewhere as agreed between the customer and Reece.

Labour and Spare Parts

The labour for the replacement of products and spare parts to which this warranty applies will be supplied by Reece or relevant supplier using licensed plumbers engaged by Reece or relevant supplier within 1 year from the date of purchase. Spare parts other than those listed in the Manufacturer's Provisions above, which are within 1 year from the date of purchase found upon inspection by an authorised Reece representative to be defective in construction, material or assembly, will be replaced free of charge.

Warranty Conditions

This warranty will apply only under all of the following conditions:

- The item has been installed by a licensed plumber
- Failure is due to a fault in the manufacture of the product
- Proof of purchase (including the date of purchase) is provided
- The installation of the product is in accordance with the instructions provided

This warranty does not cover products purchased as an ex-display without being fully checked and tested for sale by the manufacturer.

This warranty does not include faults caused by:

- Unsuitable or improper use
- Incorrect installation or installation not in accordance with the instructions provided
- Installation or part installation by the purchaser or any person other than a LICENSED PLUMBER
- Normal wear and tear
- Inadequate or complete lack of maintenance
- Chemical, electrochemical or electrical influences
- Harsh detergents or abrasive cleaners used on product finishes

EXCLUSIONS

To the fullest extent permitted by law, Reece excludes all liability for damage or injury to any person, damage to any property, and any indirect consequential or other loss or damage.

CLAIM PROCEDURE

For all warranty queries customers are to contact the branch where the product was purchased. These details can be found on your purchase invoice.

Our goods come with guarantees that cannot be excluded under the Australian Consumer Law. You are entitled to a replacement or refund for a major failure and for compensation for any other reasonably foreseeable loss or damage. You are also entitled to have the goods repaired or replaced if the goods fail to be of acceptable quality and the failure does not amount to a major failure.

Don't risk it, use a licensed plumber.™

IF AFTER CHECKING THE
INSTALLATION INSTRUCTIONS
AND IMPORTANT
INFORMATION, THE PROBLEM
HAS NOT BEEN IDENTIFIED,
CUSTOMERS ARE TO
CONTACT THE BRANCH
WHERE THE PRODUCT WAS
PURCHASED. THESE DETAILS
CAN BE FOUND ON YOUR
PURCHASE INVOICE.

General contact details for
Reece are as follows:

Reece Australia Pty Ltd

118 Burwood Hwy

Burwood VIC 3125

+61 3 9274 0000

admin@reece.com.au



WOLFEN™

reece.com.au/wolfen