

DURA EAGLE EXTENDED STEM BALL VALVE - WATER

15mm – 50mm

SPECIFICATIONS

Recommended use	Suitable for line assembly in pipeline with the principle aim to open and close flow in distribution systems.
Features	Quarter Turn Operation Real Full Bore Extended Stem Handle Chrome Plated DR Brass Ball
Working Pressure	PN20 / 2000 kPa
Temperature Range	-20°C to +100°C
Warranty	12 Months
Standards	ATS 5200.012
Watermark	WMKA00683
Threads	Rp Series AS / ISO 7.1



PHYSICAL SPECIFICATIONS

1 Body	DR Brass
2 Ball	DR Brass Chrome Plated
3 Bonnet	DR Brass
4 Seal Ring	PTFE
5 O-Ring	EPDM
6 Stem	DR Brass
7 Washer	PTFE
8 Long Screw	Brass
9 Long Stem	Aluminium
10 Nut	Stainless Steel
11 Handle	Stainless Steel

PRODUCT CONFIGURATION

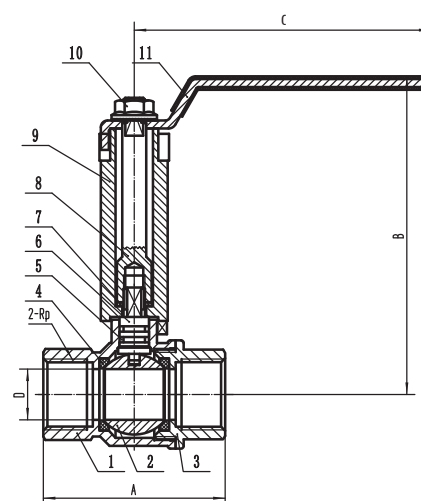

SPECIFICATIONS

Product Code	Product Description	Size	A	B	C	D
		DN	mm	mm	mm	mm
9503271	DURA EAGLE BALL VALVE F&F EXT STEM 15MM	15	60	107	85	14
9503272	DURA EAGLE BALL VALVE F&F EXT STEM 20MM	20	68	122	115	19
9503273	DURA EAGLE BALL VALVE F&F EXT STEM 25MM	25	83	124	115	24
9503274	DURA EAGLE BALL VALVE F&F EXT STEM 32MM	32	98	134	130	30
9503275	DURA EAGLE BALL VALVE F&F EXT STEM 40MM	40	108	138	155	38
9503276	DURA EAGLE BALL VALVE F&F EXT STEM 50MM	50	127	157	155	48