

# DIMAX BACKFLOW ASSEMBLY BOLT KIT FOR DCV AND RPZ DEVICE WITH Y-STRAINER AND LUGGED BUTTERFLY VALVES

Installation Guidelines DN 80 – DN 250



## Overview

DIMAX Backflow Prevention Bolt Kits are designed and tested for use with Zurn Backflow Prevention Valve Assemblies.

Each kit contains the number of bolts, nuts, washers and gasket/s for the assembly of a Zurn DCV or RPZ Backflow Prevention Device to a DIMAX Y-Strainer, 2 x DIMAX Lugged Butterfly Valves and end connection flanges.

This installation guideline should be used in conjunction with Zurn Backflow Prevention Install Instructions;

- [350, 350A & 350DA Series DCV 65-250mm](#) and/or
- [375 & 375A Series RPZ 65-250mm](#)

Technical details about each valve and/or fitting can be found on their respective Technical Data Sheets via the Reece Website.

If using other Backflow Prevention Valves ensure measurements are appropriate. Outer connections are based on CTS Copper Flanges, if using other products additional washers can be used to ensure correct torque is reached.

### Connections 1,2,4 & 5

per flange bolt hole  
1 x Hex Set Screw  
1 x Washer

*Gasket not required due to vulcanised seat on butterfly valve*



### Connection 3

1 x Gasket  
*Plus –*  
per flange bolt hole  
1 x Hex Bolt – Standard  
2 x Washers  
1 x Molybond Nut

## Connection Points

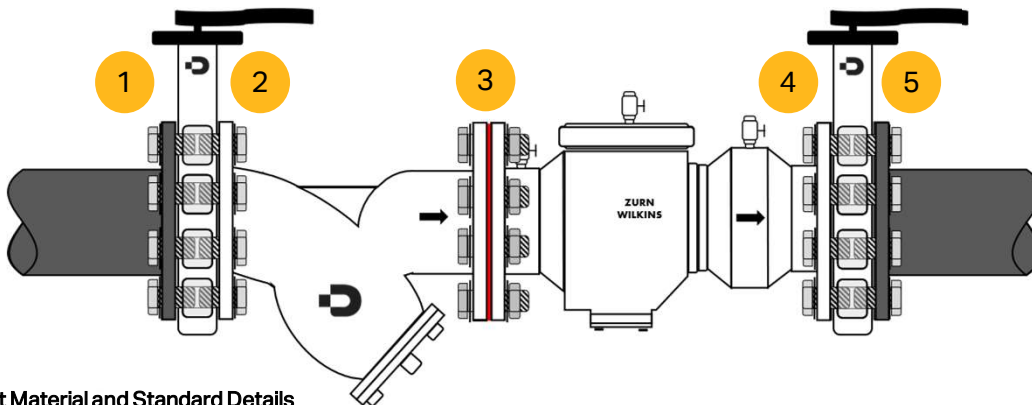

- 1 Inlet connection to Lugged Butterfly Valve
- 2 Lugged Butterfly Valve to Y-Strainer
- 3 Y-Strainer to Backflow Device (DCV/RPZ)
- 4 Backflow Device to Lugged Butterfly Valve
- 5 Lugged Butterfly Valve to outlet connection

## Kit Material and Standard Details

Nominal Size DN	Reece Code	Connection	No. of Bags	Hex Bolt Size	Hex Bolt Length Standard	Hex Bolt Standard	Hex Set Screw Length	Hex Set Screw	Nut Molybond	Washer	Full Face Gasket Solid Round AS 2129 Table E
				(m)	(mm)	qty	(mm)	qty	qty	qty	qty
Standard				316 Stainless Steel Class 50							3MM EPDM
80	1015508	Kit Total	5	M16	65	4	40	16	4	24	1
		1,2,4,5	4	-	-	40	4	-	4	4	-
		3	1	65	4	-	-	4	8	1	
100	1015510	Kit Total	5	M16	75	8	50	32	8	48	1
		1,2,4,5	4	-	-	50	8	-	8	-	
		3	1	75	8	-	-	8	16	1	
150	1015511	Kit Total	5	M20	90	8	50	32	8	48	1
		1,2,4,5	4	-	-	50	8	-	8	-	
		3	1	90	8	-	-	8	16	1	
200	1015512	Kit Total	5	M20	90	8	60	32	8	48	1
		1,2,4,5	4	-	-	60	8	-	8	-	
		3	1	90	8	-	-	8	16	1	
250	1015513	Kit Total	5	M20	90	12	60	48	12	72	1
		1,2,4,5	4	-	-	60	12	-	12	-	
		3	1	90	12	-	-	12	24	1	

# DIMAX BACKFLOW ASSEMBLY BOLT KIT FOR DCV AND RPZ DEVICE WITH Y-STRAINER AND ISOLATION VALVES

Installation Guidelines DN 80 – DN 250



## Instructions

1. Thoroughly clean the flange faces to be joined, ensuring there is no dirt, particles of foreign matter, protrusions or coating build-up on the mating surfaces. Use a scraper or wire brush to remove any irregularities
2. Ensure that the mating threads of all nuts and bolts are clean and in good condition
3. Evenly apply a suitable lubricant (e.g. molybdenum disulphide) to all mating threads, including the nut load bearing face
4. Align the flanges to be joined and ensure that the components are satisfactorily supported to avoid bending stress on the flanged joint during and after assembly
5. Insert four bolts in locations 1 to 4 as indicated on the diagram below and position the insertion gasket on the bolts, taking care not to damage the gasket surface
6. Offer the adjoining flange to the bolts, taking care to maintain alignment and support of the components
7. Tighten nuts to finger tight and check alignment of flange faces and gasket
8. Insert the remaining bolts and tighten nuts to finger tight
9. Determine the required bolt tension and the estimated torque from the Estimated Tightening Torque Values Tables
10. Tighten nuts to 30% of estimated torque using the star pattern detailed on the diagram below
11. Tighten to 60% of estimated torque using the same tightening sequence
12. Tighten to 100% of estimated torque using the same tightening sequence
13. Finish with one final pass, torquing in a clockwise direction

## Estimated Tightening Torque Values – Standard Pressure Flanges AS2129

NOMINAL SIZE DN	Bolt Size (M)	No. of Bolts Holes	Bolt Tension kN	Estimated Torques, Nm		
				Galvanised		Stainless Steel
				Lightly Oiled $\mu = 0.22$	Well Oiled $\mu = 0.15$	Well Oiled $\mu = 0.20$
80	M16	4	20	70	50	65
100	M16	8	20	70	50	65
150	M20	8	35	160	110	140
200	M20	8	35	160	110	140
250	M20	12	35	160	110	140

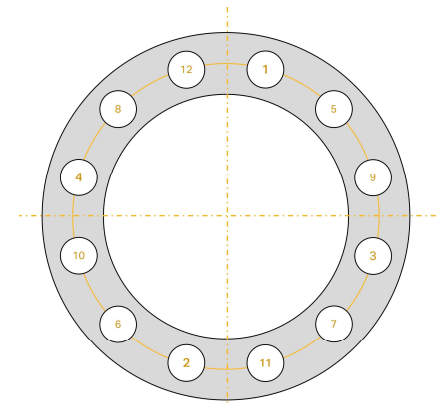

STAR PATTERN TIGHTENING SEQUENCE

'Lightly Oiled' refers to the application of a good quality lubricating oil and is the usual as received condition of fasteners.

'Well Oiled' refers to the application of molybdenum disulphide grease, or equivalent anti-seize compound.

The estimated torques provided in the tables at left are based on the coefficients of friction ( $\mu$ ) indicated. Where other coefficients apply, alternative torques should be calculated.

Required bolt tensions and estimated torques have been assessed using established engineering principles, however, variation in installation procedures may result in different requirements.

Grade 4.6 galvanised mild steel or Grade 316 property class 50 stainless steel bolts are proposed for joining Class 16 flange.

Bolt tensions have been calculated to counter the force due to expected internal pressure and to provide adequate sealing stress on the nominated gasket material, without exceeding the maximum allowable gasket stress at the time of installation. The necessary torques to induce these tensions are estimated for raised face ductile iron flanges with common surface finishes used in the Water Industry.

The application of excessive torque at the time of installation may overstress the gasket causing crushing or extrusion, which can lead to leakage at operating pressures.

The surface conditions of the threads as a result of rust, plating, coating and lubrication are the predominant factors influencing the torque/tension relationship. However there are many others including thread fit, surface texture and the speed and continuity of tightening.

The flange faces are assumed to have a surface roughness of  $R_a = 10 - 12 \mu\text{m}$

A torque wrench is most commonly utilised to achieve the required bolt tension, however in critical applications a hydraulic tensioner should be used. Special care should be taken when jointing screw-on flanges as excessive torques can cause damage to the epoxy seal.

## DISCLAIMER

All Reece trademarks and logos are owned by Reece Group Pty Ltd. All other brand or product names are trademarks or registered marks of their respective owners and displayed by agreement. Because we are continuously improving our products and services, Reece reserves the right to change specifications without prior notice.

Call 1800 032 566 or visit [www.reece.com.au/storefinder](http://www.reece.com.au/storefinder) for your nearest branch.

## CERTIFICATIONS

AS/NZS 4020 – Testing for use in contact with drinking water

WSA 109 – Flanged Gaskets and O-Rings