



Suitability:

Suitable for domestic and commercial installations to remove sediment and improve the service life of plumbing fixtures and fittings. Product Approval:

The product is certified to ATS 5200.103



Device must be installed immediately downstream of an AS/NZS 2845.1 backflow prevention valve!

Please contact your plumber!

Multipur AP

DN 65 – DN 150 Backwash filter

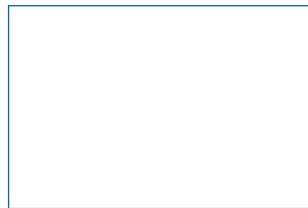

Changes reserved!



Thank you very much for the confidence that you have shown in us by purchasing a BWT appliance.



Table of Contents

| | | |
|-----------|--|-----------|
| 1 | Safety Instructions | 4 |
| 1.1 | General safety instructions | 4 |
| 1.2 | Scope of the documentation | 4 |
| 1.3 | Personnel qualifications | 4 |
| 1.4 | Transport and installation | 5 |
| 2 | Use | 5 |
| 2.1 | Intended use | 5 |
| 2.2 | Foreseeable misuse | 5 |
| 2.3 | Disclaimer | 5 |
| 2.4 | Other applicable documentation | 5 |
| 3 | Scope of supply | 6 |
| 4 | Function | 6 |
| 5 | Preliminary installation conditions | 7 |
| 6 | Installation | 8 |
| 7 | Commissioning | 9 |
| 7.1 | For parallel operation only | 10 |
| 8 | Operation | 10 |
| 8.1 | Setting the backwash interval | 10 |
| 8.2 | Manual backwashing | 10 |
| 8.3 | Display | 10 |
| 8.4 | Cleaning | 10 |
| 9 | Maintenance | 11 |
| 9.1 | Replacement of wearing parts | 11 |
| 9.2 | Troubleshooting | 11 |
| 10 | Warranty | 11 |
| 11 | Decommissioning and disposal | 11 |
| 11.1 | Decommissioning | 11 |
| 11.2 | Disposal | 11 |
| 12 | Technical Data | 12 |
| 12.1 | Overall dimensions | 14 |
| 12.2 | Volume flow rate and pressure loss | 15 |
| 12.3 | Pressure loss curves | 16 |
| 12.4 | Type label | 17 |

1 Safety Instructions

1.1 General safety instructions

The product was manufactured according to all recognised regulations and technical standards and was in compliance with the relevant legal requirements when it was put into circulation.

Nevertheless, it can pose a risk of personal injury or property damage if you do not observe this chapter and the safety instructions throughout this documentation.

- Read this documentation thoroughly and in full before working with the product.
- Retain the documentation in such a way that it is accessible to all users at all times.
- Always hand over the product to third parties together with the full documentation.
- Follow all of the instructions in relation to the proper handling of the product.
- If you detect damage to the product or the mains supply, stop its operation and notify a service technician immediately.
- Use only accessories, spare parts and consumable materials that have been approved by BWT.
- Adhere to the environmental and operating conditions specified in the “Technical data” chapter.
- Use your personal protective equipment. It ensures your safety and protects you from injury.
- Only perform tasks that are described in these operating instructions or if you have been trained to do so by BWT.
- Perform all tasks in compliance with all applicable standards and provisions.
- Instruct the operator in the function and operation of the product.
- Instruct the operator in the maintenance of the product.
- Instruct the operator in relation to potential dangers that may arise while operating the product.

1.2 Scope of the documentation

This documentation applies exclusively to the product the production number of which is listed in chapter 12 “Technical Data”.

This documentation is intended for operators, installers without training from BWT, installers with training from BWT (e.g. drinking water specialists), and BWT service technicians.

This documentation contains important information for fitting the product safely and properly, starting up, operating, using, maintaining, and disassembling the product, and for correcting simple faults independently.

Read this documentation in full before working with the product. Pay particular attention to the chapter “Safety Instructions”.

1.3 Personnel qualifications

The installation work described in these instructions requires basic knowledge of mechanics, hydraulics and electrical systems as well as knowledge of the corresponding specialist terms.

To ensure that the device is installed safely, this work must be performed only by a qualified specialist or a trained person under the guidance of a qualified specialist.

A **qualified specialist** is anyone who can assess the work assigned to him or her, identify potential risks, and take suitable safety measures thanks to his or her specialist training, knowledge and experience as well as his or her knowledge of the applicable regulations. A qualified specialist must comply with the applicable specialist regulations.

An **instructed person** is anyone who has been instructed and, if necessary, trained by a qualified specialist in the transferred tasks and the potential risks presented by improper behaviour and who has been educated about the necessary protective equipment and measures.

1.4 Transport and installation

To avoid damage during transport to the installation location, do not remove the BWT product from the packaging until you have reached the relevant location. Then dispose of the packaging in the correct manner. Check that the delivery is complete.

If there is a risk of frost, drain all components that convey water.

Lift or transport the product or its components only from the designated suspension eyes or attachment points, if present.

The product must be installed or mounted on a sufficiently strong and level horizontal surface and must be adequately secured against falling or tipping.

2 Use

2.1 Intended use

The Multipur backwash filters are used for filtration of drinking and industrial water to protect the water mains and the connected fittings, equipment, machinery, tanks, boilers and production facilities from malfunction and corrosion damage caused by foreign particles.

The filters can also be used for filtration of well, process, boiler feed, cooling and air conditioning water. In these cases, advice must be obtained from a specialist.

The filters are unsuitable for oils, greases, solvents, soaps and other lubricating media. Water-soluble substances also cannot be separated off.

2.2 Foreseeable misuse

Operating the system with parameters other than those specified in this documentation and in section 2.1.

Not adhering to the prescribed maintenance and service intervals.

Using spare parts and consumables not approved by BWT.

2.3 Disclaimer

The manufacturer is released from any liability if the customer intentionally or forcibly removes guards or safety devices, if the customer wilfully modifies or circumvents the same, or if the customer does not follow the instructions in this operating manual or on the system.

2.4 Other applicable documentation

Observe all documents from suppliers that were included with delivery. These are considered part of this documentation and must not be changed or removed.

3 Scope of supply

Backwash filter Multipur AP, consisting of:

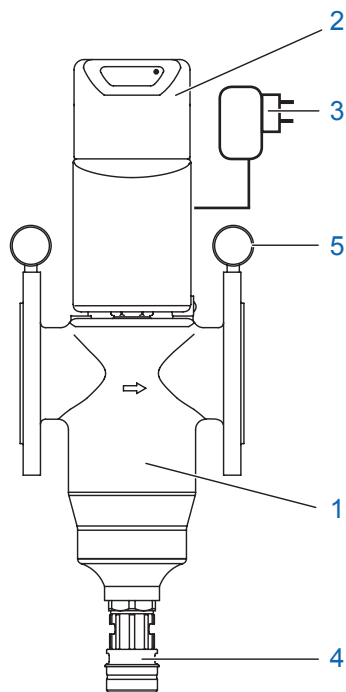

| | |
|---|---|
| 1 | Filter housing made of red brass |
| 2 | Electronic controller and backwashing device with hydraulic drive, CIC connection |
| 3 | Power supply unit |
| 4 | Water outlet for pipe / water outlet for hose (20 mm Ø) |
| 5 | Pressure gauge |
| | CIC connection cable |

Accessories

| | |
|---|-----------------|
| Interlock cable for parallel operation 2 m, with plug | Order no. 10908 |
|---|-----------------|

4 Function

The untreated water flows through a stainless steel filter element in the Multipur. Foreign particles > 100 µm are thus retained. Depending on their size and weight, these particles either fall directly into the lower part of the filter housing, or adhere to the filter element.

During backwashing, the seal at the rinsing water outlet opens. The suction ring segments of the backwashing element move from the bottom to the top and back again over the entire filter surface and thus clean the filter fabric by suction with clean water at an extremely high flow rate.

Backwashing is carried out automatically at the end of the set interval.

The pressure difference between the untreated water inlet and the treated water outlet of the filter is measured.

The backwashing process is triggered primarily by differential pressure.

If heavy soiling of the filter element causes the pressure difference to exceed the preset value (approx. 80 kPa) within the preset backwash interval, the differential pressure generator causes the unit to backwash. The preset backwash interval starts again.

The filter is equipped with a central instrumentation and control (CIC) connection (contact closes in the event of malfunction or power failure).

5 Preliminary installation conditions

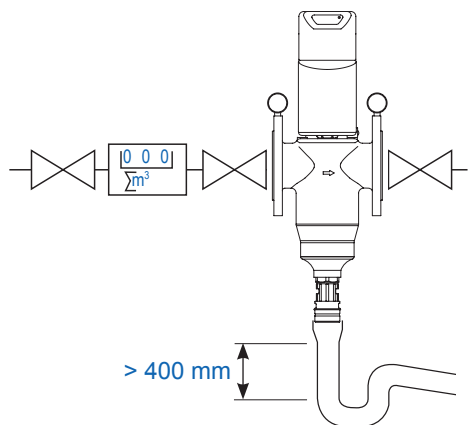

For Multipur AP 65, Multipur AP 80
and Multipur AP 100:
Drainage connection min. DN 50

For Multipur AP 125 and Multipur AP 150:
Drainage connection min. DN 75

Local plumbing codes, general guidelines and the technical data must be observed.

The system must be installed by the water supply utility or a plumbing company approved by the water supply utility in accordance with these installation and operating instructions and the applicable regulations.

The installation site must be frostproof and ensure that the filter is protected from solvent vapours, heating oil, leas, acidic cleaners, chemicals of all kinds, direct UV radiation and heat over 40 °C.

A separate power socket (230 V AC, 50 Hz) within a distance of approx. 1.2 m is required. The power supply must be permanently ensured. Voltage peaks over 1 kV must be avoided.

If the water contains dirt particles > 2 mm, a coarse dirt trap must be installed upstream from the filter.

A flushing water quantity of at least 1.4 l/s (5 m³/h) must be available for backwashing.

A drainage connection (min. DN 50/75) must be available for discharge of the rinsing water.

Avoid extreme pressure surges (caused, for example, by downstream solenoid valves or similar).

6 Installation

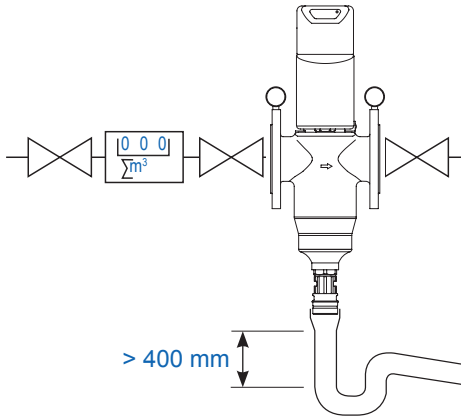

Install the backwash filter horizontally in the cold water line in the flow direction. (Observe the flow direction arrow on the filter casing.)

Piping must be conducted according to AS/NZS 3500.1

Screw on the waste water connection, either for pipe or for hose. Connect the drain line.

According to AS/NZS 3500.2 pipes discharging over a tundish shall have an airgap of a size at least twice the internal diameter of the discharging pipe.

If desired, an external fault signal issued by a potential-free contact can be connected to the building automation system terminals.

Put in pressure relief hose from the solenoid valve in the upper cutout of the drain connection respectively in the sloping drill hole of the hose liner.

A mains power outlet must be available in the immediate vicinity (max. 1.2 m away). The power supply unit is rated at IP40.

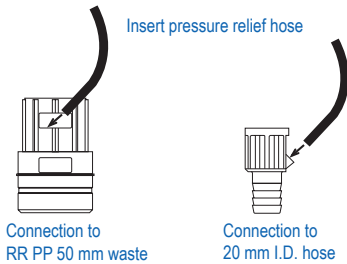

For Multipur AP 65, Multipur AP 80 and Multipur AP 100:
Drainage connection min. DN 50

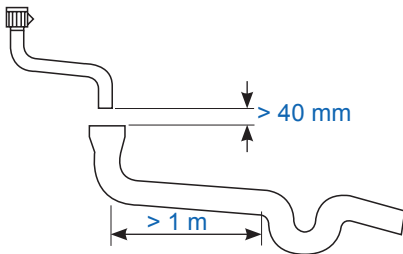

For Multipur AP 125 and Multipur AP 150:
Drainage connection min. DN 75

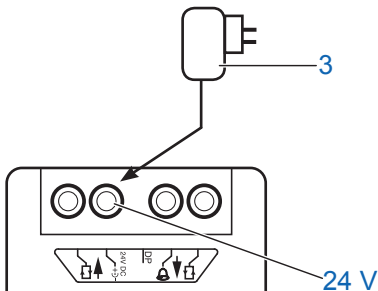

7 Commissioning

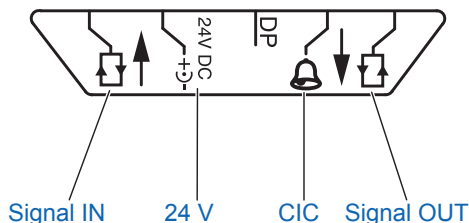
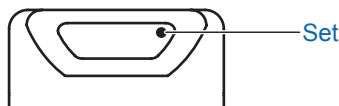

Check that the filter and flushing water pipe have been properly installed.

Slowly open the stop valves up- and downstream of the filter. Deaerate the pipework at the next bleed point downstream of the filter, and drain water briefly. Check the seals of the installation and filter for leaks.

Insert the cable plug connector of the power supply unit into the socket (24 V).

Plug in power supply unit with plug (3). The first backwashing cycle is performed automatically (during backwashing the illuminated segments on the display turn).

The factory setting 7 d (7 days) appears.

The required backwash interval must be set on the filter.

Press Set to set the interval.

| Key | Display |
|--|---------|
| Press Set for 5 seconds | SL 0 |
| Display dots flash - device is in programming mode | |
| Press Set | SL 1 |
| Press Set | SL 2 |
| Press Set | SL 3 |
| Press Set | 1 h |

Pressing the Set key again steps up the number of **h** (hours) or **d** (days).

The hours **h** run from 1 – 24, followed by days **d** from 2 – 56, followed by the hours again etc.

Press the Set key until the desired value has been set. The value is saved 10 seconds after the last input. The display dots fade out. The unit backwashes.

The time until the next backwashing and the pressure difference appear alternately in the display. The pressure difference is only displayed for large volumes of water.

The filter is ready for use.

When 2, 3 or a maximum of 4 filters are operated in parallel, they must be electrically interlocked to prevent simultaneous backwashing.

Insert an interlocking cable into the output of any one filter, representing filter 1, and run the cable to the input of filter 2. Insert the next interlocking cable into the output of filter 2, and run it to the input of filter 3. The output of the last filter is returned to the input of filter 1.

The required backwash interval must be set at the filter to be backwashed first (master) (see above).

The second filter (slave) must be set as follows:

| Key | Display |
|---|---------|
| Press Set for 5 seconds | SL 0 |
| Display dots flash - device is in programming mode | |
| Press Set | SL 1 |
| Wait 10 seconds, dots stop flashing. | |
| The pressure appears in the display (0.0 P, when no water is used). | |

A third filter must be set to SL 2 and a fourth to SL 3. Disconnect and reconnect all filters to the mains power supply. The filters will be backwashed in sequence: Master, SL 1, SL 2 and SL 3.

The time until the next backwashing and the pressure difference appear alternately in the master filter display. The pressure difference is only displayed for large volumes of water.

Only the pressure difference appears in the slave filter display.

The filters are ready for use.

8 Operation

We recommend programming the filter so that the device is backwashed at least once a month to prevent foreign particles from adhering to the filter element (more frequently for higher levels of soiling; factory setting every 7 days).

8.1 Setting the backwash interval

Should the local water quality (degree of contamination) change, the backwashing interval must be corrected; see commissioning.

8.2 Manual backwashing

Unplugging and plugging in the device can backwash it at any time.

8.3 Display

The time until the next backwashing and the pressure difference appear alternately in the display. The pressure difference is only displayed for large volumes of water.

8.4 Cleaning

Clean plastic parts with a soft, damp cloth only; do not use solvents, detergents, or acidic cleaning agents.

9 Maintenance

It is recommended and to assist in the longevity of your Multipur unit, that regular maintenance occurs. This should always be undertaken by specialist staff who will also replace worn parts.

We advise you to conclude a maintenance contract. Maintenance must be performed once each year, and twice each year for municipal systems, by your local plumber/installer.

9.1 Replacement of wearing parts

| | |
|--------------------------------|----------------|
| Seals | every 3 years |
| Backwashing element | every 6 years |
| Filter element | every 6 years |
| Groove ring | every 6 years |
| Lock ring | every 6 years |
| Hose barb | every 9 years |
| HT-Connector | every 9 years |
| Hydraulic tubes | every 9 years |
| Difference pressure transducer | every 9 years |
| Pressure spring | every 12 years |

9.2 Troubleshooting

| Fault | Cause | Action |
|--|---|---|
| Water pressure dropped considerably in network | Dirty filter element | Carry out backwash |
| Flushing water outlet does not close | Backwash element does not reach the end position due to large particles of dirt | Repeat backwash several times |
| AP only: Display shows ERR | Pressure too low | Repeat backwash several times. Increase pressure |

If the fault cannot be remedied by following these tips, contact our after-sales service department.

10 Warranty

In the event of a malfunction during the warranty period, please contact our after-sales service department, stating the type of unit and the product number (PNR) (see the technical data or the type plate on the unit).

11 Decommissioning and disposal

11.1 Decommissioning

The product may only be shut down and dismantled by qualified specialists.

Observe all applicable safety regulations when dismantling the system.

11.2 Disposal

| NOTICE | |
|---|---|
|  | <ul style="list-style-type: none"> ▶ At the end of the product's life cycle, ensure that it is properly disposed of or recycled. ▶ Observe the legal disposal guidelines for the country in which the product is used. ▶ The following materials are used in the product: metal, plastic |

| Multipur AP | Type | 65 | 80 | 100 |
|--|-------------------|------------------------------------|-----------|------------|
| Nominal connection width | DN | 65 | 80 | 100 |
| Connection type | | Flange connection DIN 2501, Part 1 | | |
| Flange Ø | mm | 145 | 160 | 180 |
| Flangebore Ø | mm | 18 | | |
| Nominal flow | m ³ /h | 58 | | 82 |
| Flow capacity at $\Delta p = 20$ kPa | m ³ /h | 35 | | 56 |
| Flow capacity at $\Delta p = 50$ kPa | m ³ /h | 58 | | 82 |
| Micron rating | µm | 100 | | |
| Nominal pressure (PN) | kPa | 1000 | | |
| Operating pressure p_o min./max. | kPa | 250 – 1000 | | |
| Recommended operating pressure | kPa | 250 – 800 | | |
| Minimum pressure behind filter (for backwashing) | kPa | 250 | | |
| Water temperature , min./max. | °C | 5 / 30 | | |
| Ambient temperature, min./max. | °C | 5 / 40 | | |
| Length of backwashing, approx. | s | 10 | | |
| Rinsing water volume at 400 kPa | l | 16 | | 24 |
| Water flow at backwashing | l/h | 5700 | | 8600 |
| Mains connection | V/Hz | 230/50 | | |
| Operating voltage | V- | 24 | | |
| Power consumption, max. | W | 8 | | |
| Power consumption during backwashing, max. | W | 12 | | |
| CIC - dry contact, switching capacity max. | V / A | 24 / 1 (resistive load) | | |
| Protection class | | IP54 | | |
| Drainage connection, min. | DN | 50 | | |
| Operating weight, approx. | kg | 15 | 18 | 24 |
| Shipping weight, approx. | kg | 13 | 16 | 21 |

| Multipur AP | Type | 125 | 150 |
|--|-------------------|------------------------------------|-----|
| Nominal connection width | DN | 125 | 150 |
| Connection type | | Flange connection DIN 2501, Part 1 | |
| Flange Ø | mm | 210 | 240 |
| Flangebore Ø | mm | 18 | 22 |
| Nominal flow | m ³ /h | 91 | 105 |
| Flow capacity at Δp = 20 kPa | m ³ /h | 57 | 61 |
| Flow capacity at Δp = 50 kPa | m ³ /h | 91 | 105 |
| Micron rating | µm | 100 | |
| Nominal pressure (PN) | kPa | 1000 | |
| Operating pressure p _o min./max. | kPa | 250 – 1000 | |
| Recommended operating pressure | kPa | 250 – 800 | |
| Minimum pressure behind filter (for backwashing) | kPa | 250 | |
| Water temperature , min./max. | °C | 5 / 30 | |
| Ambient temperature, min./max. | °C | 5 / 40 | |
| Length of backwashing, approx. | s | 10 | |
| Rinsing water volume at 400 kPa | l | 30 | |
| Water flow at backwashing | l/h | 10000 | |
| Mains connection | V/Hz | 230/50 | |
| Operating voltage | V- | 24 | |
| Power consumption, max. | W | 8 | |
| Power consumption during backwashing, max. | W | 12 | |
| CIC - dry contact, switching capacity max. | V / A | 24 / 1 (resistive load) | |
| Protection class | | IP54 | |
| Drainage connection, min. | DN | 75 | |
| Operating weight, approx. | kg | 33 | 38 |
| Shipping weight, approx. | kg | 28 | 32 |

AUS 12.1 Overall dimensions

| Multipur AP | Type | 65 | 80 | 100 |
|--|------|-----|-----|-----|
| Overall height | mm | 630 | 630 | 680 |
| Height, top edge to centre of tube (H1) | mm | 310 | 310 | 310 |
| Height, lower edge to centre of tube (H2) | mm | 320 | 320 | 370 |
| Minimum distance, centre of tube to ceiling (H3) | mm | 400 | 400 | 400 |
| Minimum distance, centre of tube to floor (H4) | mm | 400 | 400 | 400 |
| Minimum distance, centre of tube to wall | mm | 100 | 105 | 115 |
| Installation length (L) | mm | 220 | | |

| Multipur AP | Type | 125 | 150 |
|--|------|-----|-----|
| Overall height | mm | 770 | 770 |
| Height, top edge to centre of tube (H1) | mm | 310 | 310 |
| Height, lower edge to centre of tube (H2) | mm | 460 | 460 |
| Minimum distance, centre of tube to ceiling (H3) | mm | 400 | 400 |
| Minimum distance, centre of tube to floor (H4) | mm | 640 | 640 |
| Minimum distance, centre of tube to wall | mm | 130 | 145 |
| Installation length (L) | mm | 220 | |

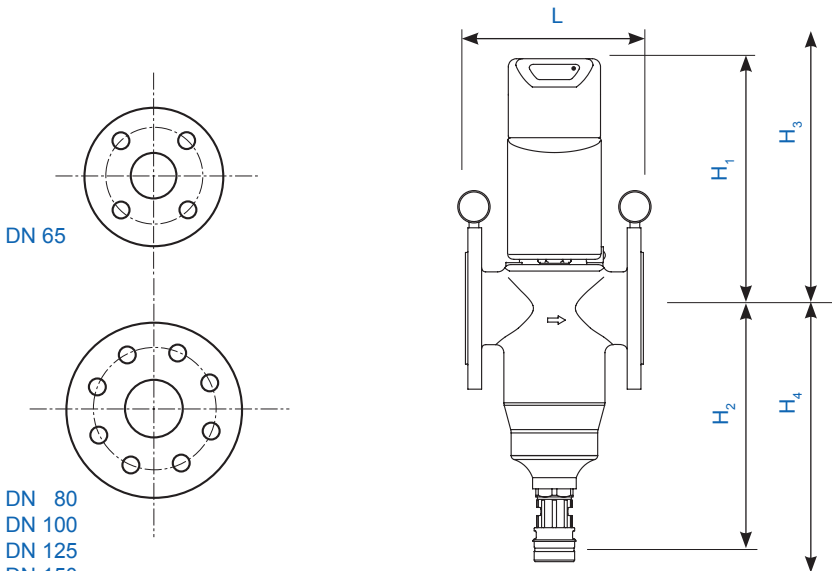

12.2 Volume flow rate and pressure loss

| Multipur AP DN 65 | | | | | | | | |
|--------------------------------------|----|----|----|----|----|-----|-----|-----|
| Volume flow rate [m ³ /h] | 15 | 22 | 35 | 44 | 51 | 58 | 72 | 81 |
| Pressure loss Δp [kPa] | 5 | 10 | 20 | 30 | 40 | 50 | 80 | 100 |
| Multipur AP DN 80 | | | | | | | | |
| Volume flow rate [m ³ /h] | 15 | 22 | 35 | 44 | 51 | 58 | 75 | 85 |
| Pressure loss Δp [kPa] | 5 | 10 | 20 | 30 | 40 | 50 | 80 | 100 |
| Multipur AP DN 100 | | | | | | | | |
| Volume flow rate [m ³ /h] | 29 | 41 | 56 | 67 | 75 | 82 | 102 | 114 |
| Pressure loss Δp [kPa] | 5 | 10 | 20 | 30 | 40 | 50 | 80 | 100 |
| Multipur AP DN 125 | | | | | | | | |
| Volume flow rate [m ³ /h] | 26 | 38 | 57 | 70 | 81 | 91 | 116 | 132 |
| Pressure loss Δp [kPa] | 5 | 10 | 20 | 30 | 40 | 50 | 80 | 100 |
| Multipur AP DN 150 | | | | | | | | |
| Volume flow rate [m ³ /h] | 25 | 40 | 61 | 79 | 93 | 105 | 137 | 155 |
| Pressure loss Δp [kPa] | 0 | 10 | 20 | 30 | 40 | 50 | 80 | 100 |

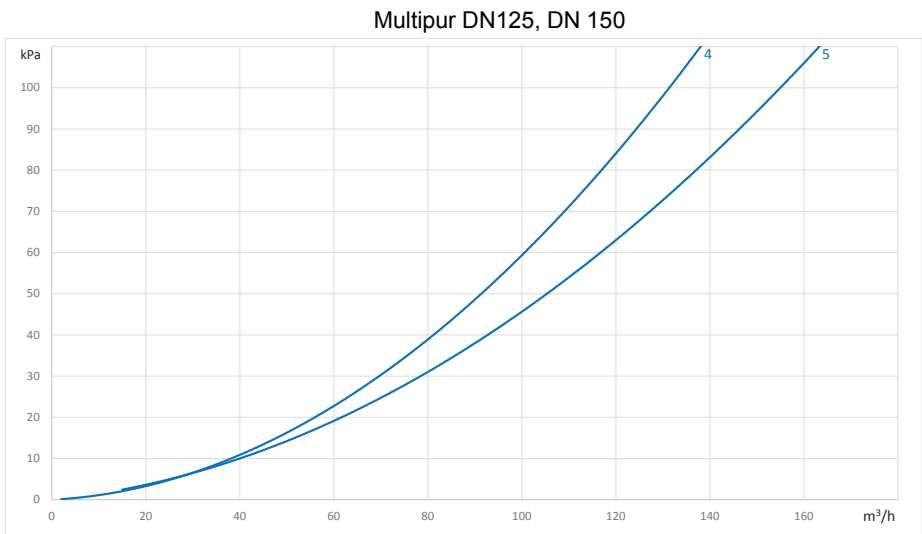
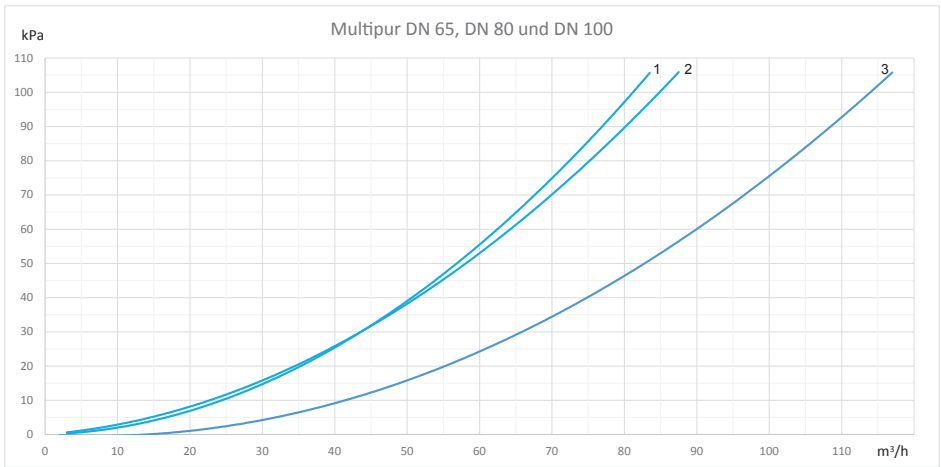

- 1 = Multipur DN 65
- 2 = Multipur DN 80
- 3 = Multipur DN 100
- 4 = Multipur DN 125
- 5 = Multipur DN 150

Multipur AP DN 65 Reece

1

Auto Backwash Filter Operating Specifications

| | |
|---|-------------------------|
| Type: | 65 |
| Nominal Size: | DN65 |
| Flow rate (m ³ /h): | 35 |
| $\Delta p=0.2$ bar | 58 |
| $\Delta p=0.5$ bar | |
| Nominal Pressure (PN) | 10 |
| Recommended Operating Pressure Range (kPa): | 300-1000 |
| Filter Efficiency (Micron): | 90-110 |
| Operating Temperature (°C): | Water 5-30 Ambient 5-40 |
| Power Consumption During Backwashing (Watts): | 8 |
| Order Number | 2 10463 |
| S/N | 3 xxxxxx |



For further information please visit www.reece.com.au

BWT - for You and Planet Blue.

BWT Wassertechnik GmbH, Industriestr. 7, D-69198 Schriesheim
 Telefon: +49 (0)6203/73-0, E-Mail: bwt@bwt.de
www.bwt-group.com



12.4 Type label

The type label serves as product identifier. In case of any requests, please have the following information ready:

1. Device name
2. Production number / Order-no.
3. Serial number / Year of manufacture

Note: The type label is an official document and must not be altered or stripped off. Damaged or unreadable type labels have to be replaced.

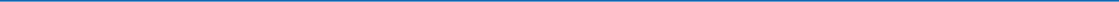

Further information:

Reece. Works for you. TM

Call **1800 032 566** or visit
www.reece.com.au for your
nearest Reece store.

Due to limitations in the printing process
the colours in this brochure are a guide
only.

The manufacturer/distributor reserves
the right to vary specifications or delete
models from their range without prior
notification. The manufacturer/distributor
takes no responsibility for printing errors.

www.reece.com.au

