SUMP PUMP INSTALLATION MANUAL

A large, stylized graphic of the letter 'V' is positioned in the lower half of the page. The top curve of the 'V' is filled with a solid orange color, while the two downward-pointing arms are filled with solid black. The graphic is centered horizontally and occupies a significant portion of the lower half of the cover.

**A smooth day is a good day.
That's why Vada is dedicated
to creating pump solutions
that you can count on. With
a focus on easy selection, simple
installation and high quality, you
can hold your head high knowing
your reputation is protected.
It's Vada. Performance simplified.**

THANK YOU



**Thank you for purchasing the Vada Sump Pump V150!
Record the product details here and leave with the owner.**

Date purchased:

Purchased from:

Purchase invoice number:

Product serial number:

Product model number:



KNOW YOUR PRODUCT

Constructed from cast iron for durability and designed with a vortex impeller for improved water flow and reduced clogging. This pump is built to handle clean and greywater and soft solids up to 15mm O.D. at a 10% content or fine solids at 1% concentration. The sump pump is supplied as standard with a 10m power cable length and connections to suit 32mm, 25mm and 20mm hose.

Note: A larger diameter hose or pipe will offer less resistance to flow and will give better performance.

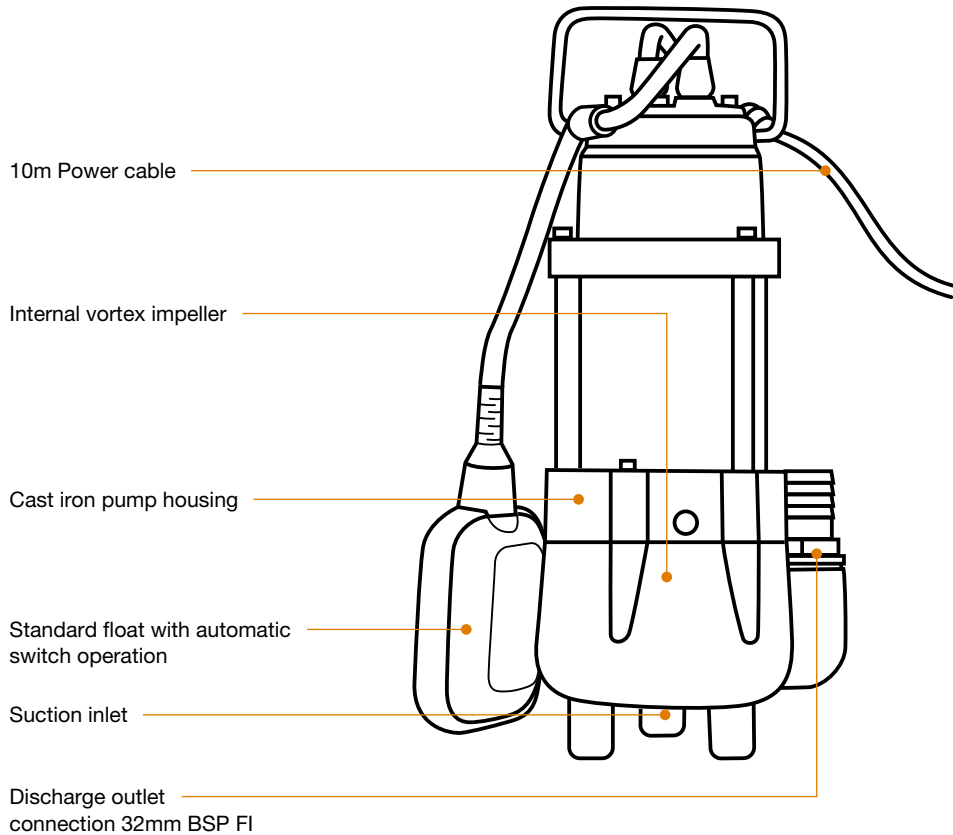

SPECIFICATIONS



- Built to handle clean and greywater with soft solids up to 15mm (no suspended solids like stones, pebbles, mulch or abrasive material such as sand, cement, dust or harsh detergents)
- Optimum operating range: 4.3–3.2 metres head, 64–96 litres per minute
- Max water temperature: 40°C
- Max submersion depth: 6m
- IP Rating: IP68
- 1PH, 230VAC $\pm 10\%$, 50 Hz, (P1) 350W, (P2) 180W, Run current 1.75 A

PIT SIZE

HELPFUL HINT

The Vada V150 requires a minimum pit size of 450mm (L) x 450mm (W) x 510mm (H) to ensure the float can rise.

If your pit is tapered, ensure the float can be fully engaged without getting caught on the pit wall.

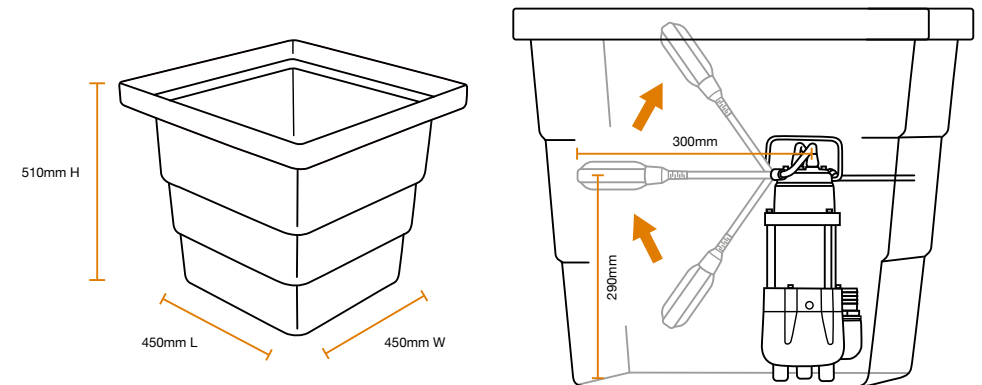

APPLICATIONS



The Vada Sump Pump V150 is suitable for the following applications:

Ground water transfer	Rainwater transfer	Emptying residential sumps and tanks	Draining of flooded buildings or cellars	Removing water from drainage collecting pits	Transferring wastewater from kitchen sinks, laundry, or baths to higher sewage lines
✓	✓	✓	✓	✓	✓

The Vada Sump Pump V150 is not suitable for the following applications:

Pumping of blackwater (wastewater with toilet discharge)	Pumping liquids containing long fibrous materials	Pumping aggressive or inflammable liquids	Pumping liquid containing solids larger than maximum recommended particle size (15mm)	Pumping liquid containing abrasive solids (stones, ceramics etc.)
✗	✗	✗	✗	✗

INSTALLATION

PREPARING FOR INSTALLATION

For a successful installation, ensure you have all pieces listed below.

What we've supplied:

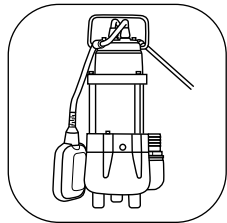

□ Vada Sump Pump V150

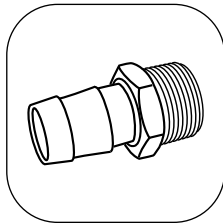

□ x3 Hose barbs (20mm, 25mm, 32mm)

What you'll need to supply:

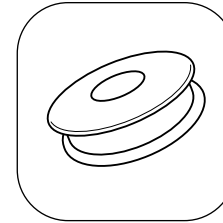

□ Teflon tape

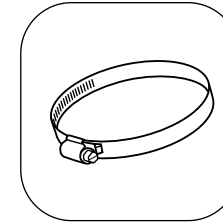

□ Hose clamps

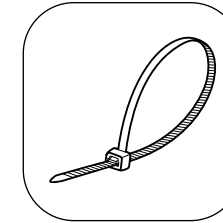

□ Cable ties

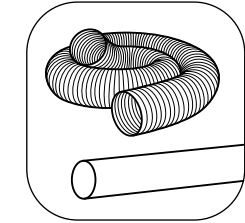

□ Discharge hose (hard or flexible)

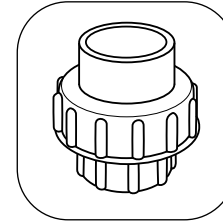

□ Barrel union FI

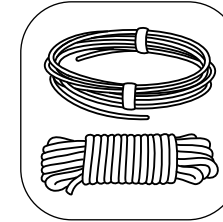

□ Nylon rope or stainless-steel cable (safe working load of 10kg)

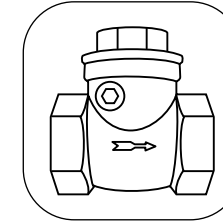

□ Swing check valve

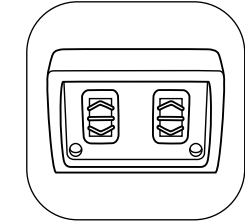

□ Access to a 10A power point

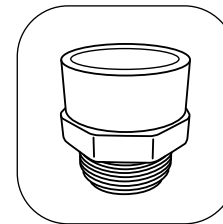

□ Valve socket to suit pipework 32mm MI (if you're using a hard discharge pipe)

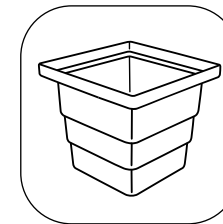

□ Stormwater pit (may be required)

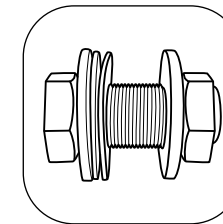

□ Poly tank outlet (may be required)

The residence must also have a Residual Current Device (RCD), also known as Electrical Leakage Circuit Breaker (ELCB). This is a safety switch located in the Fuse Box.

INSTALLATION



PART 1: PUMP LOCATION

Let's get down to business.

Note: Ensure the pump is being installed by a qualified, licensed personnel. The pump should be in good condition and should be used in a residential application.



In accordance with AS3350.2.41 we are obliged to inform you that this pump is not to be used by children or infirm persons and must not be used as a toy.



The pump must be supplied by an outlet protected by a residual current device or earth leakage circuit breaker with a maximum rated residual current of 30mA.



Illustrations below are an example only.

1. Ensure you have access to a 10A weatherproof outdoor powerpoint in a dry and flood free location. Do not plug the pump in.

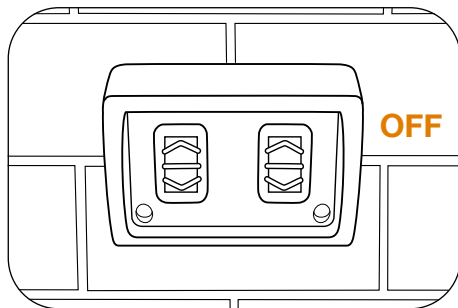

2. Position your sump pump in the tank/pit/well. If using a pit, we recommend using a minimum pit size of 450 (L) x 450 (W) x 510mm (H) to allow enough space for the float to rise.

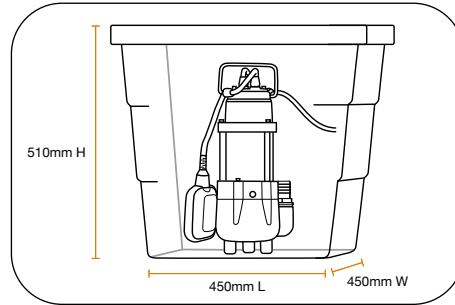

Note: If needed, loop the nylon or steel rope through the top to lower the Sump Pump. Do not use the power cable or the float to lower the Sump Pump.

3. Check the set up so far. The surface the pump sits on should be solid. There should be enough clearance between the base of the pit and suction to prevent sediment and debris from entering the pump and there should be enough room for the float to rise.

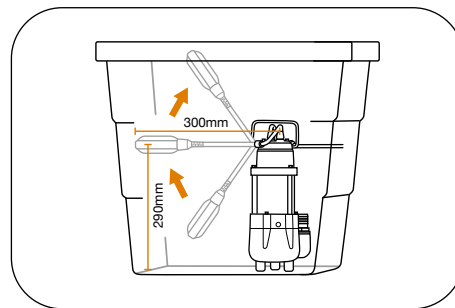

PART 2: DISCHARGE SET UP

Now that your sump pump is positioned, it's time to set up the discharge pipework.

Ensure you have selected the position for your discharge outlet on the pit, cut a hole to size on the pit and then secure a tank outlet (or similar).

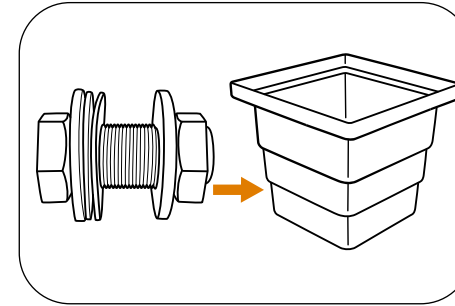

Note: The length and the diameter of the discharge hose impact the pressure and flow rate the sump pump can deliver.

Note: All components used must have a pressure rating that exceeds the maximum pressure of the pump by an appropriate safety factor.

1. Wrap a hex nipple in Teflon and fit it to the tank outlet (or similar).

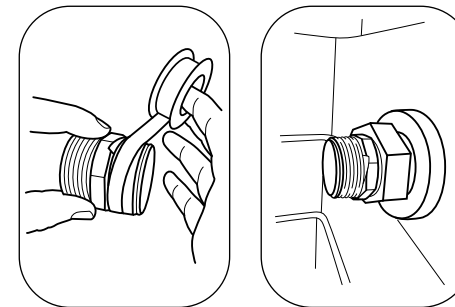

2. Fit a check valve to the hex nipple. The check valve will prevent fluid from re-circulating when the pump has stopped.

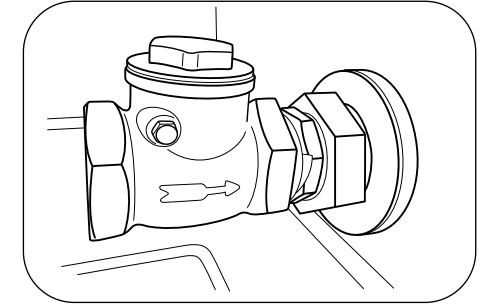

3. Connect the discharge pipe to the outlet using one of the following options

a. If you're using a hard discharge pipe:

- i. Wrap a valve socket with Teflon tape.

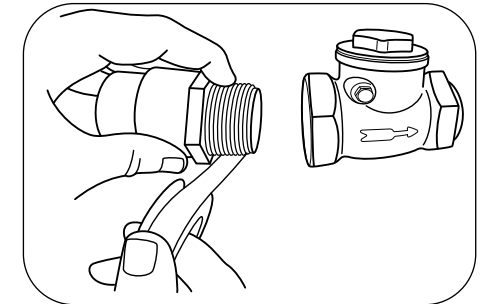

- ii. Fit the valve socket to the check valve to facilitate easy maintenance.

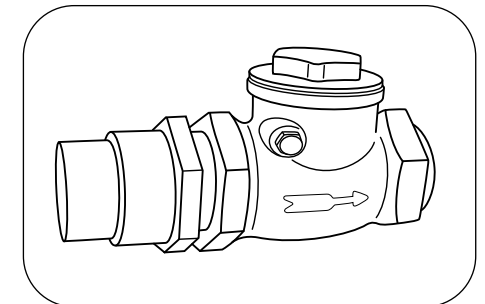

INSTALLATION



- iii. Wrap a 32mm MI valve socket in Teflon tape then connect it to the pump outlet.

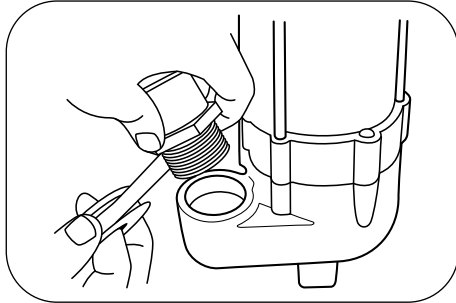

- iv. Connect your pipework, ensuring you include a barrel union for easy maintenance.

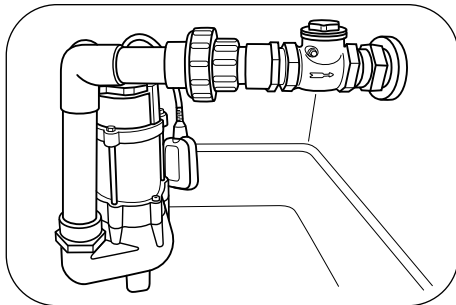

b. If you are using a flexible discharge hose:

- i. Secure the hose to the Sump Pump outlet and check valve by using one of the hose barbs (provided) and hose clamps.

Note: The outlet is 32mm FI. Use one of the hose barbs provided to suit your set up.

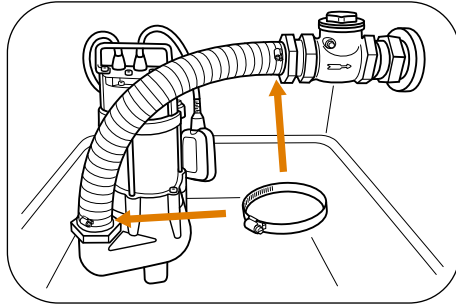

4. Check that all pipework is supported independently from the pump.



PART 3: ELECTRICAL SET UP

It's time to power up!



In accordance with AS 3350.2.41 we are obliged to inform you that this pump is not to be used by children or infirm persons and must not be used as a toy.

1. Ensure the power supply cord is supported by the delivery pipes at 3 metre intervals.

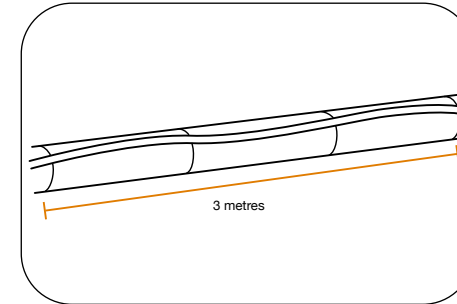

2. Ensure the powerpoint is in a dry and flood free location.

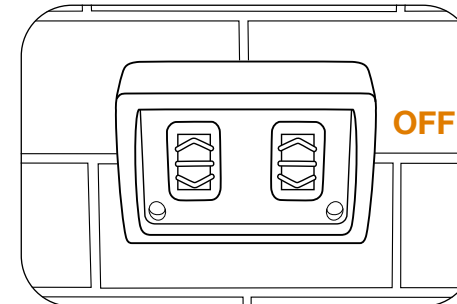

3. Plug the power supply cord into the 10 Amp powerpoint. Do not switch on.

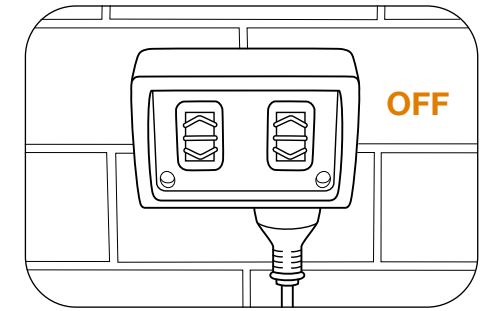

Note: Supply voltage that is outside the limits specified can cause the motor to overheat leading to overload tripping, reduced component life or seriously damage pump, voiding warranty.

Note: For additional protection, the pump must be supplied from an outlet protected by a residual current device – RCD (also known as an Electrical Leakage Circuit breaker – ELCB) with a maximum rated residual current of 30mA.

OPERATION

 Do not run pump dry. Ensure that pump is submerged in water before operating.

1. Turn the power on at the power point.

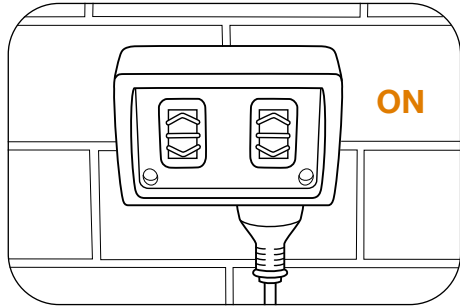

2. Put a small amount of water in the tank/pit/well, enough to cover the pump completely.

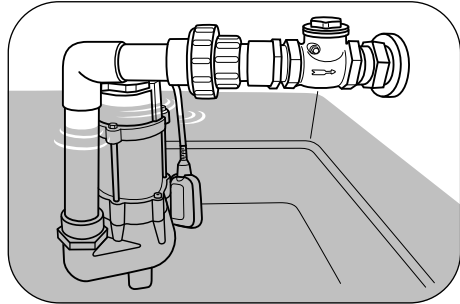

3. The float switch will rise and the pump will start to empty the pit.

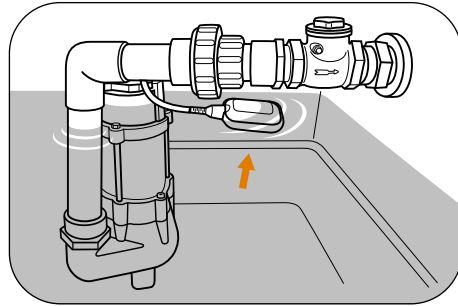

4. As the pit empties, the float switch will fall and the pump will stop.

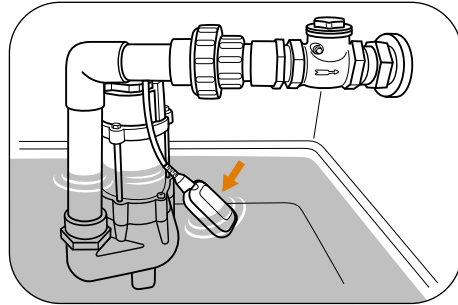

Note: There is a small port hole in the base of the pumping unit. On occasion, this will expel air bubbles should air become trapped within the pump housing. This is a normal operation.

SERVICE & MAINTENANCE



 Turn off power to motor and remove plug from power outlet before working on pump or motor.

Under normal conditions, the Vada V150 Sump Pump requires low maintenance and is simple to service.

To avoid possible failures, we recommend periodically checking the flow and pressure supplied and current absorption for the following:

- A decrease in pressure. This is a symptom of wear.
- An increase in current absorption. This is a sign of abnormal mechanical friction in the pump and/or motor which may be caused by debris caught in the impeller.

CHECKING THE FLOW

1. Get a bucket of a known size (e.g. 10 litre bucket) and place it near the Sump Pump.
2. Get a hose and connect it from the final discharge point to the bucket.

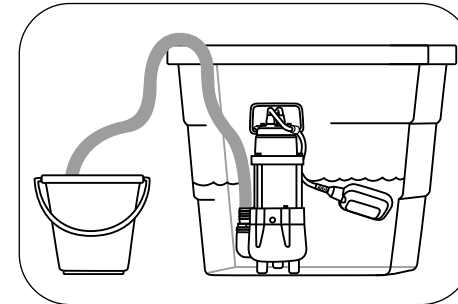

3. When the pump is operating, time how long it takes to fill the bucket.

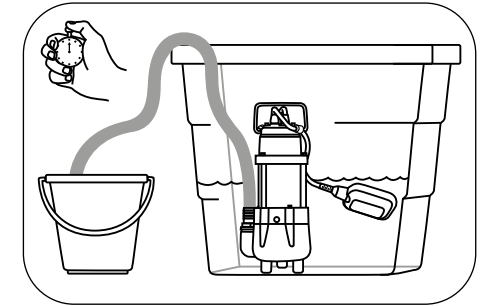

4. Enter the bucket size and time it takes to fill the bucket to the formula below.

$$1. \text{ Bucket size} \times 60 = V$$

$$2. V \div \text{time it takes to fill the bucket} = \text{flow in litres per minute}$$

Example: I am using a 10L bucket. It takes **8.5 seconds** for the bucket to fill.

$$1. 10 \times 60 = 600$$

$$2. 600 \div 8.5 = 70$$

Therefore, my Sump Pump is producing 70 litres per minute.

If the answer (litres per minute) is between 64 and 96, the sump pump is operating within the optimum operating range.

Note: Optimum operating range is 4.3–3.2 metres head, 64–96 litres per minute.

STORING THE PUMP

If the pump is not going to be used for long periods of time (e.g. 6+ months), it should be completely emptied, rinsed with clean water and stored in a dry, shaded place.

PUMP PERFORMANCE CURVE

Pump curves are a great tool to understand the optimum operating range, in relation to head (metres) and flow (l/min). Pump curves can be interpreted by tracing your finger along the Head (Metres) across to Flow (litres per minute).

In the pump curve below, you can see that if the Vada Sump Pump V150 has a discharge head between 4.3–3.2m (43–32kpa), then the pump will produce between 64–96 l/min, and will operate in the optimum operating range.

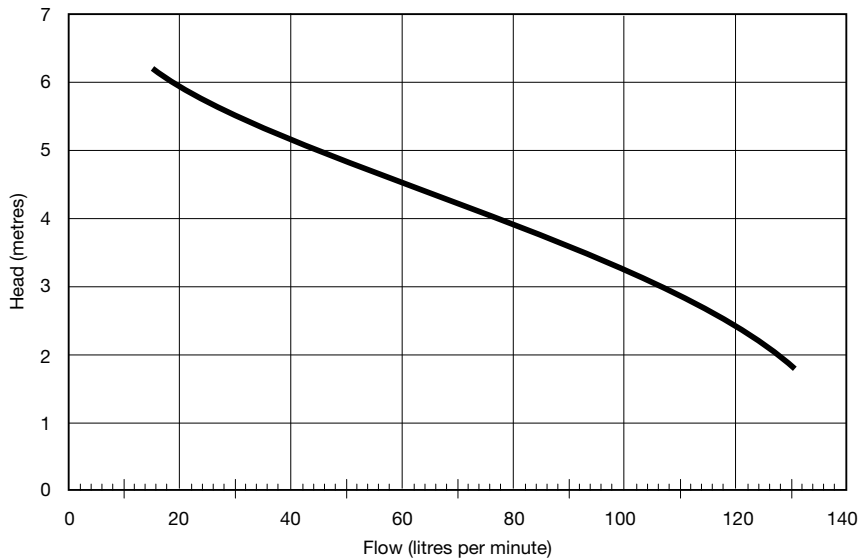

Note: Operating outside the optimum operating range over an extended time period will result in a shortened product lifespan.

Note: Should you require further specific information or assistance with calculating the system duty of your application please contact your local Reece branch.

PRODUCT DIMENSIONS



- A. 165mm
- B. 80mm
- C. 310mm
- D. 357mm
- E. 78mm
- F. 122mm

Pump 'off' height: 75mm
 Pump 'on' height: 500mm
 Pump weight: 9kg

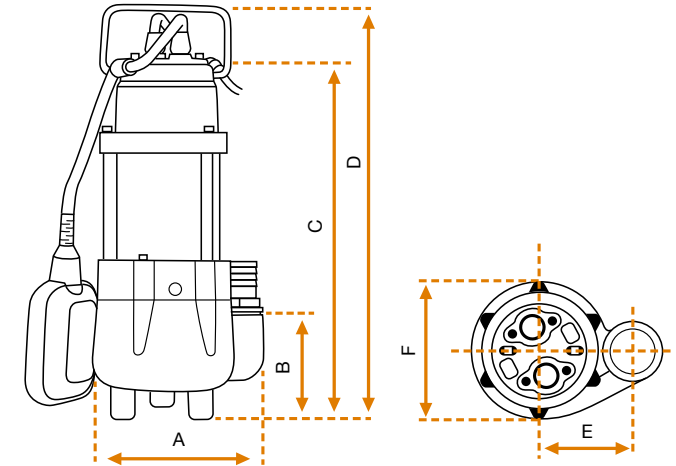

TECHNICAL INFORMATION

CONSTRUCTION	
Power Cable	H07RN-F
Float Switch	H07RN-F
Pump Housing	Cast Iron
Pump Shaft	304 Stainless-steel
Motor Shell	304 Stainless-steel
Mechanical Seal	Carbon ceramic
Oil Seal	Nitrile
Impeller	Polycarbonate

POWER	
Power Consumption	0.18 Kw
Voltage	1~230V±10% 50Hz
Full Load Current	1.75 A
Starting Current	9.5 A

USAGE LIMITATIONS	
Max Flow Rate	150 l/min
Max Water Temp	40°C
Max Submersion Depth	6m
Max Soft Solids Width	15mm
Max Concentration of Fine Solids	1%
IP Rating	IP68

Note: The Vada V150 Sump Pump MUST be used with clean or grey water with no suspended solids like stones, pebbles, mulch, or abrasive material such as sand, cement, dust, or harsh detergents.



Having trouble? Sort it out here, quick smart.

If these solutions do not solve the problem, please visit your local Reece branch.

SYMPTOM	CAUSE	SOLUTION
Sump Pump does not start	The float switch is not in the 'on' position	Wait until there is enough water in the pit to start the pump by filling water from a garden hose into the pit and visibly looking to check that the float operation is not impaired. Physically lift the float switch vertically if needed.
	The float is caught on something and cannot rise	Ensure that the float can move freely. Ensure the pit size is in line with the minimum recommended size of 450mm (L) x 450mm (W) x 510mm (H).
	There is no power supply	Ensure that the pump is connected to a live outlet.
		Reset the circuit breaker. If a problem persists contact a licensed service technician or electrician to evaluate the fuses and circuit breakers.
The Sump Pump is 'blocked' (i.e. the impeller is jammed)	Disconnect the pump from the power outlet, and check to ensure no foreign matter jamming the suction at the bottom of the Sump Pump. If there is foreign matter externally, remove it.	
There is no water coming from the Sump Pump	There are blockages in the Sump Pump or discharge line	Disconnect the pump from the power outlet and check the pump housing and discharge for foreign matter. Ensure that the pump is not attempting to handle solids more than 15mm O.D. Ensure the pump is suitable for your application (see page 6).
	There is excessive lift	Ensure that the height that you are trying to lift water is within the pump's capacity. See the pump performance chart on page 14. If your requirements fall outside this chart, you will need a different pump. Contact your local Reece branch for support.
	There is not enough water in the pit to start the Sump Pump	Wait until there is enough water in the pit. Ensure the float switch is operating freely. When water is present, the pump will function.

SYMPTOM	CAUSE	SOLUTION
Sump Pump will not stop, even though there is barely water in the pit	The float switch is trapped in the 'up' position	Ensure that the float can move freely. Ensure the pit size is in line with the minimum recommended size of 450mm (L) x 450mm (W) x 510mm (H).
	The float switch is fused 'on'	The float switch needs replacing. Contact a licensed professional, or get in contact with a Reece branch for support.
Sump Pump runs intermittently; thermal protection inside the pump is tripping and resetting	The Sump Pump is not completely submerged	Ensure the Sump Pump is covered with water. Ensure the pit size is in line with the minimum recommended size of 450mm (L) x 450mm (W) x 510mm (H).
	Water temperature is too high	This Sump Pump is designed to handle water up to 40°C. If the water is above this temperature, the pump is not expected to function.
	When the Sump Pump shuts off, water in the discharge line is running back into the pit, lifting the float switch. It is likely a check valve has not been installed.	Fit a check valve at the pump discharge so that water cannot return to the pit. As per installation instruction a check valve MUST be installed. Refer to page 9–10 for instructions.



WARRANTY

You have purchased a quality product from Reece. This product is covered by a 2 year product warranty. This warranty covers faults in the product construction, material, and assembly.

If a product is suspected of being faulty, please contact the Reece store it was purchased from and the product will be inspected by an authorised Reece representative. Products which are found upon inspection to be defective in construction, material, or assembly, will be replaced with an equivalent product free of charge within the warranty period outlined above. Replaced items become Reece's property.

All replacement products will be available for collection without charge to the customer at the nearest Reece branch to the customer's location, or elsewhere as agreed between the customer and Reece.

Any attempt to repair the device by the customer or unauthorised third parties shall terminate the warranty.

WARRANTY CONDITIONS

The warranty will apply only under all the following conditions:

- The pump has been installed by a qualified, licenced personnel.
- The installation manual has been adhered to.
- The pump is in good condition and has not arrived damaged.
- The pump is located so that it will NOT be prone to freezing.
- The pump is being used with clean and grey water and is NOT being used with alternative fluids specifically abrasive, corrosive, or explosive fluids.

- The pump is isolated from electrical supply during installation and any subsequent service work.
- The electrical installation is in accordance with the national wiring rules (AS/NZS 3000) for class 1, IP68 rated products.
- The pump has NOT been lifted/moved/carried by the electrical or float switch cables.
- The pump has NOT run dry or with the motor exposed (i.e., out of the water for long periods). Running the pump dry will harm the pumps seal and overheat the motor.
- The Vada V150 is correctly sized for your application.
- The pump has been installed for and subjected to domestic residential use only subject to local building a municipality guideline.
- Failure is due to a fault in the manufacture of the project. In this case, proof of purchase including the date of purchase is required.

This warranty does not include faults caused by:

- Failure to adhere to the conditions above
- Normal wear and tear
- Inadequate or complete lack of maintenance
- Chemical, electrochemical, or electrical influences
- Harsh detergents or abrasive cleaners used on product finishes.

EXCLUSIONS

To the fullest extent permitted by law, Reece excludes all liability for damage or injury to any person, damage to any property and any indirect consequential or other loss or damage. To the maximum extent permitted by law, Reece excludes all warranties other than those set out above.

