

MIZU

DRIFT WALL BATH AND BASIN MIXER SET

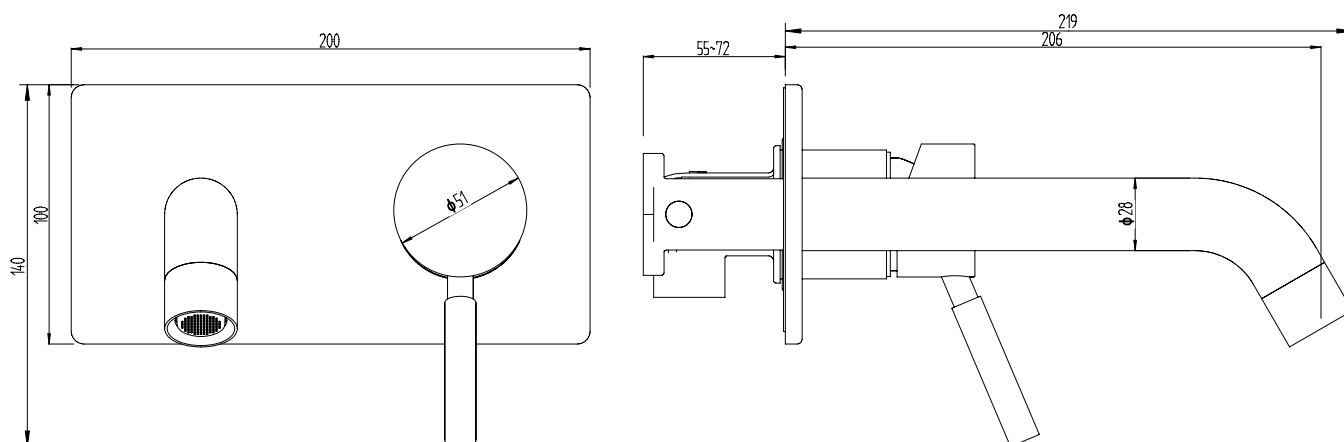

Dimensions are nominal measurements only.

SPECIFICATIONS

Recommended use	Domestic, hotel and commercial
Colours	Chrome or Black
Pressure rating	<p>Maximum continuous operating pressure 1000kPa.</p> <p>Note: As per AS/NZS3500 pressure must be limited to 500kPa on any new home, extension or renovation.</p> <p>Note: For best performance and longer life we recommend an operating pressure between 150-500 kPa</p> <p>Hot and cold water inlet pressure should be equal.</p>
Temperature rating	Maximum continuous working temperature 65°
WELS	Basin Outlet Stars 4, Flow Rate 7.5 L/min
Standards	AS/NZS 3718



To see the complete Mizu range go to www.reece.com.au/bathrooms

CLEANING RECOMMENDATIONS

We recommend the use of soapy water or approved cleaners.

This product should not be cleaned with abrasive materials.

Damage caused by any improper treatment is not covered by the product warranty - refer to Warranty Conditions.

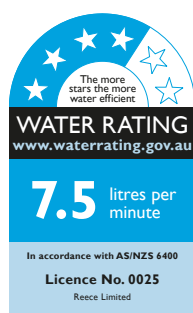

OR
Unrated for
wall bath
mixer sets

W
WaterMark
AS/NZS 3718
WM 022094

Disclaimer: Products in this specification manual must by regulation be installed by licensed and registered trade people. The manufacturer/distributor reserves the right to vary specifications or delete models from their range without prior notification. Dimensions are nominal measurements only. Dimensions and set-outs listed are correct at time of publication however the manufacturer/distributor takes no responsibility for printing errors.

Tech Page Version 1

m i z u **reece**

MIZU

DRIFT WALL BATH AND BASIN MIXER SET

INSTALLATION INSTRUCTIONS

Note

Mixer must be installed to the requirements of AS/NZS 3500 by a qualified plumber. Your mixer comes to you already factory assembled and tested. We do not recommend the dismantling of any internal part of the mixer. The mixers are factory tested and sealed so as to give the best performance.

1. Please flush out new pipe work prior to connecting the new mixer.
2. This mixer is suitable for high pressure where both hot and cold water supply is at 150kPa or above.
3. During installation protect the exposed finish surface by using the plastic cover provided. Please pay attention to the minimum/maximum depth. Allow for finished wall thickness.
4. In a typical installation, the mixer is mounted on the timber/metal noggin and secured with screws (not provided).
5. Mixer must be installed with water outlet on the left as per image 1. Connect the mixer to hot and cold water supply as per markings on mixer body.
6. Pressure test all connections. Leaking joints are not covered by the warranty.
7. Push on outlet and secure with grub screw.