

THERMANN™

INSTALLER'S MANUAL

Gas Continuous Flow Water Heaters

**Installation Details
Warranty**

Models

16NG50-6/16LP50-6
16NG60-6/16LP60-6
20NG50-6/20LP50-6
20NG60-6/20LP60-6
26NG50-6/26LP50-6
26NG60-6/26LP60-6



Thermann Installer's Manual
Gas Continuous Flow Water Heaters

CONTENTS

Important Safety Instructions	4
Electrical Connection	5
Introduction	6
Exploded Diagram of Unit	7
Dimensions	8
Technical Data	9
Cold Water Connection	10
Hot Water Connection	10
Gas Connection	11
Electrical Connection	11
Remote Controllers	12-17
Cascade Installation	18-19
Cascade Set Up	19
Cascade Installation Flowchart	20
Wiring Diagram and Remote Controls Installation Schematic	21
Fault Monitor	22

IMPORTANT SAFETY INSTRUCTIONS

DO NOT INSTALL INDOORS

This unit is designed for outdoor installation and should never be installed indoors as this can cause oxygen deficiency and incomplete combustion.



WATCH FOR GAS LEAK

When gas leak is noticed, stop using the unit immediately and close the gas valve.

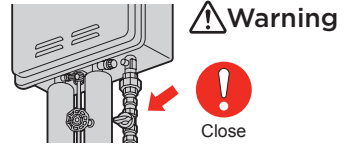
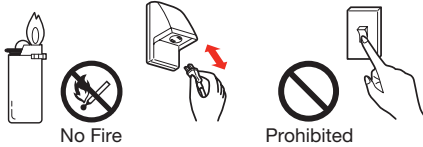

CONFIRM TYPE OF GAS AND POWER SUPPLY

Make sure to use the gas type as well as power supply (voltage/frequency) as indicated on the label located on the cabinet side.

Natural Gas or Propane will be printed on the gas type label.

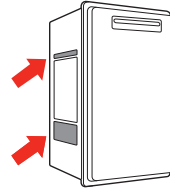

FREEZE PREVENTION

This unit comes equipped with electric heaters that prevent the water heater from freezing. To enable this freeze prevention system to operate there must be an electrical power supply connected to the unit.

The freeze prevention devices will not operate if the electrical power source is not connected. The electric defrost heaters are installed inside the water heater only. All external hot and cold water supply pipes and fittings connected to the water heater should be properly insulated to prevent freezing.

SECURE SERVICE SPACE

Make sure there is enough space around the unit for checking, service and maintenance.

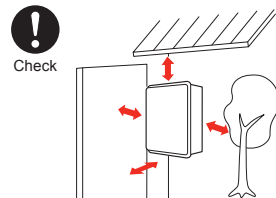

ELECTRICAL CONNECTION

DANGER OF WET HANDS

Do not touch power plug with wet hands. It can cause electric shock.



INSERT POWER PLUG FULLY INTO POWERPOINT

Check that the power plug is clean and undamaged, then fully insert into the power point.

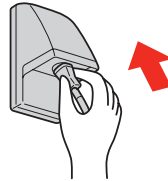

DO NOT PULL POWER CORD

Do not remove the power plug by pulling the cord as it may generate heat by wire breakage and cause fire.

Hold the plug when removing the power cord.

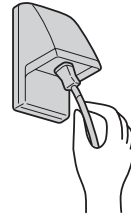

DO NOT USE POWER CORD BUNDLED

Never use power cord in a bundled condition. It can cause heat generation and fire.

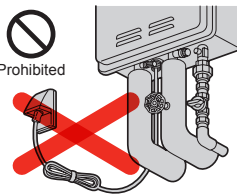

DO NOT REPLACE POWER CORD

If the power supply cord is damaged, it should be replaced by a cord available from your local Reece branch. The power cord must be replaced by an authorised tradesperson.

WARNING:

For continued safety of this appliance it must be installed, operated and maintained in accordance with the manufacturer's instructions.

INTRODUCTION

This product is an external electronic gas hot water heater.

These units are factory set to deliver 50°C or 60°C depending on the model purchased.

If the unit has a factory setting temperature higher than 50°C and is intended to deliver water directly to sanitary fixtures used primarily for the purposes of personal hygiene, it must be fitted with an approved tempering valve into the hot water piping to any bathroom and/or ensuite.

If the Thermann 20 or 26 model is for use as a solar booster, the setting temperature must be altered to 70°C (refer to the temperature setting instructions on the wiring diagram sheet which is attached to the unit, inside the front cover). For this application, these instructions must be read in conjunction with the Thermann solar hot water system technical (installation) manual.

Up to three optional remote controllers can be provided for complete hot water temperature selection. If this option is used an approved temperature limiting device must be installed on any units with a delivery temperature above 50°C.

THIS HOT WATER UNIT IS NOT FOR POOL OR SPA HEATING

GENERAL

The Thermann Continuous Flow must be installed in accordance with the following:

- (1) These instructions;
- (2) National Construction Code and Local authority regulations;
- (3) AS/NZS 3500.4 "Plumbing and Drainage - Heated Water Services",
- (4) The Australian standard for gas installations AS/NZS 5601;
- (5) Any other statutory regulation that may apply;
- (6) A notice of intention to install shall be lodged with the relevant local Gas Authority prior to installation.

DELIVERY INSPECTION

The Thermann Gas Continuous Flow hot water heater unit is supplied fully assembled and ready for installation.

The installer, upon delivery of the unit, should immediately remove all packing materials and inspect the unit for damage, and ensure that the unit supplied is correct for the gas supply to which it is to be connected. If any concerns, please report any damage or discrepancies to Reece, quoting the serial number and model number, which can be found on the outside of the cabinet.

INSTALLATION MUST BE CARRIED OUT ONLY BY AN AUTHORISED AND APPROPRIATELY LICENSED PERSON.

EXPLODED DIAGRAM OF UNIT

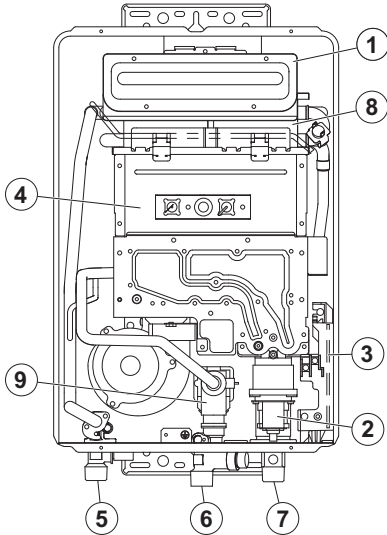

Model : 16/20

PARTS DESCRIPTION

1. FLUE OUTLET
2. GAS VALVE
3. CIRCUIT BOARD
4. BURNER CASE
5. HOT WATER OUTLET
6. COLD WATER INLET
7. GAS SUPPLY INLET
8. HEAT EXCHANGER
9. WATER VOLUME PROPORTIONAL VALVE

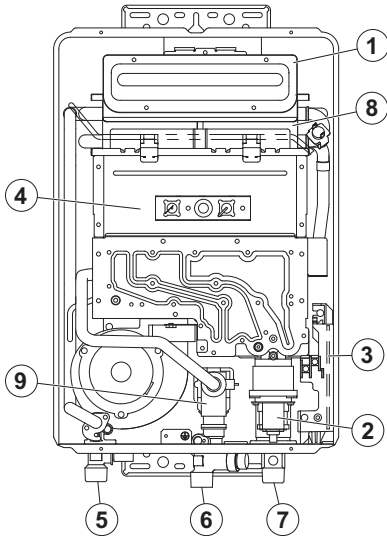

Model : 26

PARTS DESCRIPTION

1. FLUE OUTLET
2. GAS VALVE
3. CIRCUIT BOARD
4. BURNER CASE
5. HOT WATER OUTLET
6. COLD WATER INLET
7. GAS SUPPLY INLET
8. HEAT EXCHANGER
9. WATER VOLUME PROPORTIONAL VALVE

DIMENSIONS - ALL MODELS

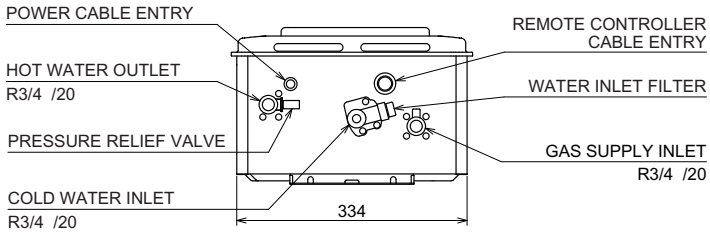
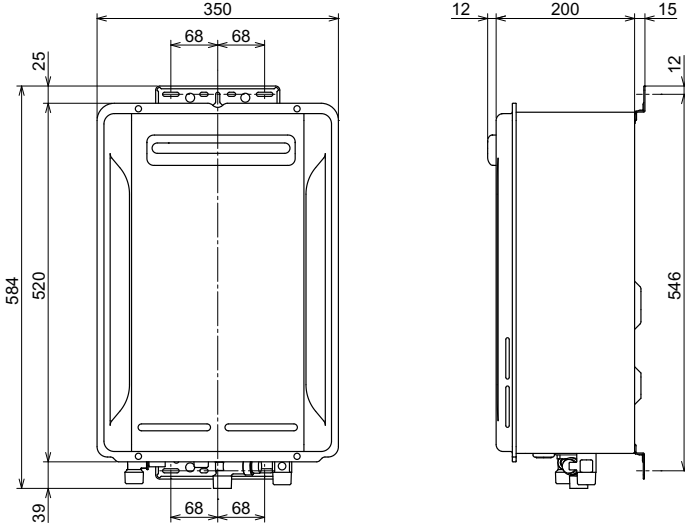

TECHNICAL DATA

MODEL		16	20	26
Nominal hourly gas consumption by proportional electronic gas control	MJ/h	125	158	200
Test point pressure (NG)	kPa	0.56	0.80	0.80
Test point pressure (Propane)	kPa	0.91	1.40	1.50
Water heating capacity @ 40°C rise	L/min	10	12.5	16.25
Minimum working pressure	kPa	60	90	110
Maximum working pressure	kPa	1200	1200	1200
Gas injectors diameter (NG)	mm	0.95 / 1.45	0.95 / 1.45	1.15 / 1.65
Gas injectors diameter (Propane)	mm	0.65 / 0.95	0.65 / 0.95	0.7 / 1.0
Input voltage single phase 50Hz	V	240	240	240
Maximum output current	A	0.39	0.45	0.46
Inlet gas connection male thread		R3/4" (20mm)	R3/4" (20mm)	R3/4" (20mm)
Cold water connection male thread		R3/4" (20mm)	R3/4" (20mm)	R3/4" (20mm)
Hot water connection male thread		R3/4" (20mm)	R3/4" (20mm)	R3/4" (20mm)
Relief valve pressure setting	kPa	1400	1400	1400
Weight dry	kg	15	15	16
Dimensions (DxWxH)	mm	200 x 350 x 520	200 x 350 x 520	200 x 350 x 520

IAPMO Approval certificate no. GMK10409. Watermark Certificate of compliance WM-000506

DATA PLATE

Left outside of cabinet.

GAS TYPE

The gas label is located on the left outside of cabinet. The label will be either Natural Gas or Propane. The nominated gas is the gas that this appliance is designed to operate with.

DO NOT OPERATE WITH ANY OTHER GAS TYPE.

WARNING LABELS

Located on the side of the cabinet. **PLEASE READ THESE LABELS CAREFULLY.**

INSTALLATION LOCATION

**THIS HEATER IS APPROVED FOR OUTDOOR INSTALLATION ONLY.
IT IS NOT SUITABLE FOR INDOOR USE.**

Refer to AS/NZS 5601 for clearance requirements of flue termination. In addition, ensure that the appliance installation location permits easy access for maintenance and operation.

MOUNTING THE APPLIANCE

The heater must be installed by using a fixing method which is sufficient to support the weight of the unit. Refer to diagrams on page 8 for dimensions of mounting brackets and positions. The top bracket has a centre hole so that the appliance can be positioned by hanging it on one screw, then other screws can be secured.

COLD WATER CONNECTION

COLD WATER SUPPLY TO WATER HEATER

Refer to the Dimensions diagrams on page 8 for the position of connections.

Copper tube of a minimum size of 3/4" (DN20) should be connected to the appliance.

The water inlet connection is R3/4" (20mm) male BSP and require a union to allow for removal of the water heater.

Pipe sizing from the cold water supply should be sized according to local BY LAWS for water supply.

This appliance is intended to be connected permanently to the water supply and not connected by a temporary method such as a garden hose.

ISOLATING VALVE

A full flow isolation valve such as a gate valve or ball valve together with a disconnection union must be used on the cold water inlet to the water heater.

THIS REQUIREMENT IS AN AUSTRALIA WIDE REQUIREMENT UNDER THE NATIONAL PLUMBING CODE.

If the above instruction is not carried out, all warranties on the unit will be voided.

Stop taps or combination stop taps and non-return valves are not to be used.

NOTE: No pressure reduction valve is required unless the inlet water pressure exceeds 1400kPa at any time.

HOT WATER CONNECTION

Refer to Dimensions diagrams on page 8 for the position of connection.

The outlet connection is male thread R3/4" (20mm) for all models and requires union connection to allow for removal of the unit.

Install the hot water supply line from the unit with copper tube with a minimum of R3/4" (20mm).

For units set at 50°C, a minimum of 1.8 metres of 20mm pipe must be run before the first outlet.

Keep the pipe lengths to a minimum and make sure that the pipework is well insulated, as correct performance of the appliance is dependent on properly insulated pipework.

DO NOT FIT ANY VALVES OR RESTRICTORS TO THE OUTLET OF THE WATER HEATER.

DO NOT FIT ANY OBSTRUCTION TO THE PRESSURE RELIEF LOCATED ON THE HOT WATER OUTLET CONNECTION.

After purging the air from the system using the hot water supply taps, remove the water inlet strainer located on the cold water supply inlet connection.

Remove any debris from the filter and replace. When replacing the filter do not over-tighten the "O"ring seal.

GAS CONNECTION

Fit a union to the water heater gas inlet for easy connection and removal. The thread diameter is R3/4" (20mm).

THIS DOES NOT INDICATE THE SIZE OF THE GAS SUPPLY. Refer to AS/NZS 5601 for guidance on pipe sizing.

Fit an approved isolating gas valve and a disconnection union into the supply line adjacent to the water heater gas connection.

Ensure that the supply pipe and the gas pressure regulator (Propane or Natural Gas) has sufficient flow capacity for this and other appliances connected to the fitting line.

For Propane appliances ensure that gas cylinders are of sufficient size. The water heater alone will require a regulator of 4KG per hour capacity.

Before connecting the appliance to the gas service, purge any debris or air from the gas service. Venting of purged gas must occur in an area free of sources of ignition.

Close the isolating gas valve prior to connection of the appliance.

After connection, check all joints for leaks with an approved leak tester.

Refer to AS/NZS 5601 Installation Code for pipe sizing details.

The Thermann 16/20/26 requires a minimum of 125/158/200 MJ/h respectively.

If the gas pipe sizing is insufficient, the customer will not obtain the full performance benefit. Gas pipe sizing must consider the gas input to this appliance as well as all the other gas appliances in the premises.

Service calls are chargeable for units installed with incorrect pipe sizes.

⚠ Danger: In the case that the water piping is accidentally connected to gas connection port, all parts of gas circuit must be replaced. If the unit is operated without replacement, it may cause gas leakage, explosion or fire.

ELECTRICAL CONNECTION

The appliance is equipped with a three pinned earthed plug to be connected to a 240V 50Hz power supply. The electrical rating of the appliance is 0.39/0.45/0.46Amp. for the Thermann 16/20/26 respectively.

The appliance requires a 240V 50Hz weatherproof power outlet installed in a protected position adjacent to the appliance.

IMPORTANT: The appliance should always be disconnected from the power supply before any maintenance is carried out.

The installer must check appliance operation at the completion of installation.

TESTING THE WATER HEATER AFTER INSTALLATION IS COMPLETED.

Turn on power supply to the heater and allow approximately 30 seconds for the computer to perform a safety check. Open a hot water tap and check the temperature of the hot water supplied. The burners will not light if the flow rate is less than 3L/min.

IF THE UNIT FAILS TO OPERATE, CONSULT THE FAULT MONITOR (LAST PAGE).

REMOTE CONTROLLERS

1. NUMBER OF CONTROLLERS

One, two or three remote control panels can be installed as optional extras.

2. CONTROLLER LOCATIONS

The controllers allow the water temperature to be set from the various locations where they are installed at kitchen, laundry, bathroom and ensuite.

IMPORTANT

DO NOT locate the remote controls where they may come into contact with water.

DO NOT position the remote controls in the vicinity of chemicals.

DO NOT position the remote controls over a cooker, grill oven or toaster.

DO NOT position the remote controls where materials may spill onto them.

3. CONNECTION OF WIRING TO THE THERMANN UNIT

1. Remove the front cover from the unit.
2. Install the wiring to the Thermann main unit using conduit or by concealing the wires in the wall cavity.
3. Install the wiring into the cabinet through the conduit.
4. Attach the wiring to the plate adjacent to the terminal block, using the cable clamp provided. Then attach the wires to the terminals for the remote controls. Replace the front cover of the water heater.

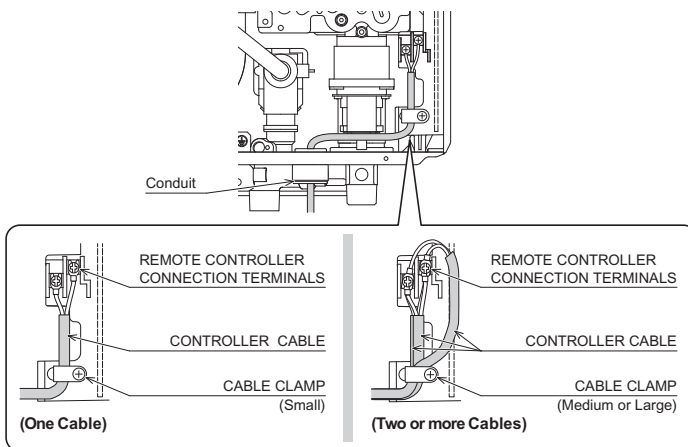

REMOTE CONTROLLERS

4. INSTALLATION OF CONTROLLERS

Safety precautions

- Disconnect the heater from the power supply before connecting remote controller cables.
- Do not install a remote controller above a heat source such as a hot plate or a kitchen range. The heat will cause electrical component problems, or deform the exterior.
- Do not install the main remote controller where it will be subjected to splashing water or steam from appliances.
- Do not install the remote controller in a position that will be exposed to direct sunlight.
- Do not install the remote controller where any commercial chemicals such as ammonia, sulfur, chlorine, ethylenic compound and acids etc are used.
- The remote controller cables carry low voltage, 12VDC.

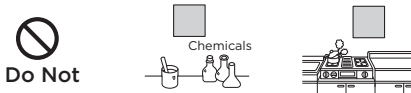

Installation For Kitchen (see figure on page 14)

- Install conduit inside of wall in advance. Alternatively conceal wires inside wall cavity.
- Pass remote controller cables through conduit/wall cavity.
- Connect the remote controller cables to the quick connector on the rear of the controller.
- Detach face plate from the remote controller using screwdriver and fix it to the wall directly with screws (2pcs) in the screw holes provided. Then attach face plate again. Do not tighten the screws excessively, as the screw hole may be damaged.

REMOTE CONTROLLERS

Installation For Bathroom

- Before remote controller installation, check the hole position considering wall stud location.
- Drill a 12mm hole in a wall for the remote controller cable.
- Feed controller cable to controller wall location. Pull cable end connector through hole.
- After passing the controller cable through the hole, connect to the quick connector on rear of controller and feed spare cable back into wall.
- Detach face plate from the remote controller.
- Fix the remote controller to the wall with screws (2pcs) in the screw holes provided. Do not tighten the screws excessively, as the screw hole may be damaged. In case of mounting the remote controller on tile, cement or mortar, use appropriate wall anchors. Then attach covers again.

*Seal the remote controller against the wall by running a bead of suitable sealant around it. Failure to adequately seal against the wall may result in water intrusion into the controller causing damage.

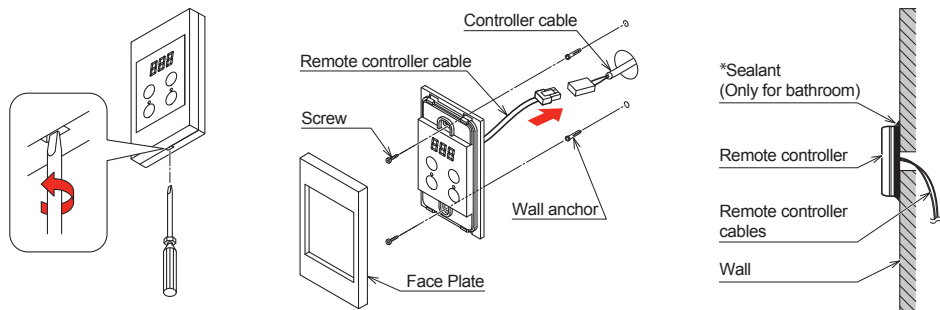

REMOTE CONTROLLERS

5. INITIAL SETTING OF CONTROLLERS

Before using, the following initial setting procedure is necessary for all remote controllers.

The first time the remote controller is connected, "Lo" is indicated on the display.



Select "Lo" or "Hi" by pushing \ominus or \oplus button.
 Hi(temp.) : Kitchen Controller
 (Only one controller can be set to "Hi")

Lo(temp.) : Bathroom or Ensuite Controller(s)



After selecting "Lo" or "Hi", press "ON/OFF" button for 5 seconds until a beep is heard. "Fin" will appear on the display after the setting is completed.

When all initial settings have been set, all connected remote controllers will be powered on automatically indicating "40°C" on the display.

The remote controllers cannot be turned on until the initial setting of ALL connected remote controllers has been completed.

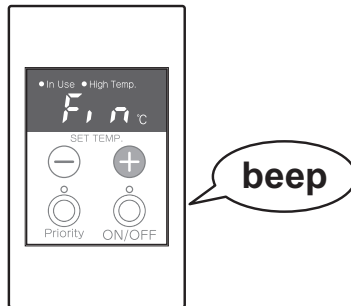

NOTE: To Reset Controllers

- When completing the kitchen controller's setting and repeating this procedure for other (bathroom or ensuite) controllers, "Hi" cannot be selected (only "Lo" is displayed).
- When turning on the remote controller after the initial setting, make sure the hot water supply temperature is displayed on each controller.
- If Bathroom or Ensuite controller is set to "Hi" by mistake, the initial setting will need to be cancelled to change the setting back to "Lo".
- To cancel the initial setting, push "ON/OFF" button and "Priority" button simultaneously for 5 seconds. When the setting is cancelled, "Lo" is indicated on the display. Then perform the initial setting procedure again.

REMOTE CONTROLLERS

6. COMMISSIONING AND TESTING

After completing the installation of the unit, turn the water, power and gas supplies on to the unit.

7. OPERATION OF CONTROLLERS

Turn the remote control in a kitchen ON by pressing the ON/OFF button on the control to the ON position. The ON indicator will illuminate.

The digital monitor will indicate 40°C and the priority indicator will illuminate.

Using the \ominus or \oplus buttons select the hot water temperature required. Turn on the hot water supply tap. The "In Use" indicator will show that hot water is being supplied.

Move to the control in a bathroom and/or ensuite (if fitted). Press the PRIORITY BUTTON and repeat the procedure.

**THERE ARE NO MINOR ADJUSTMENTS THAT CAN BE MADE TO THE UNIT.
CONFIRM IGNITION, COMBUSTION AND EXTINCTION.**

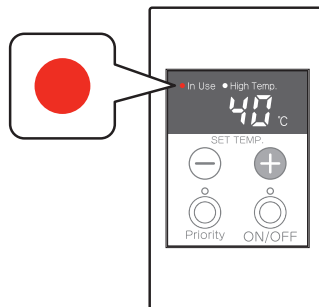

Check ignition, combustion and extinction of the unit by the "In Use" indicator light of the controllers.

REMOTE CONTROLLERS

YST-2807

(Universal Controller)

This remote controller is intended to be used in the kitchen, laundry room, bathroom and ensuite.

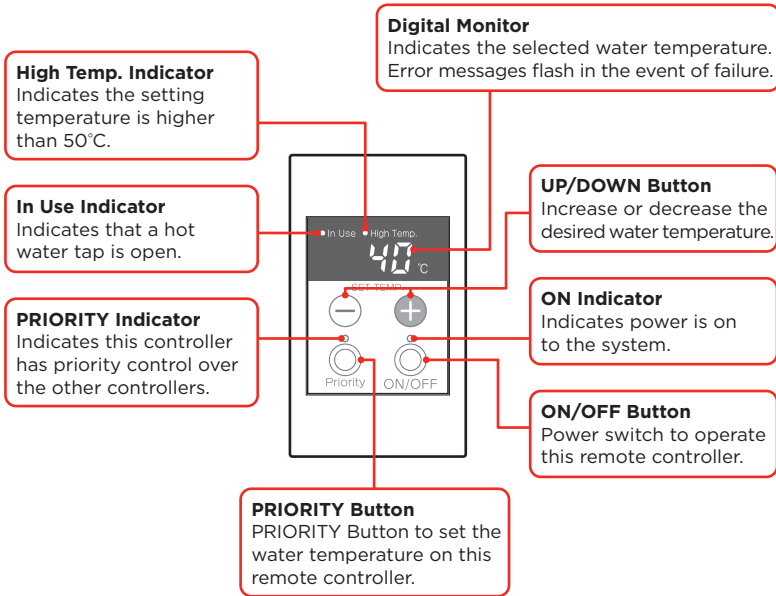

The unit will deliver the selected temperature as follows:

Kitchen Controller:

37, 38, 39, 40, 41, 42, 43, 44, 45, 46, 47, 48, 49*, 50*, 55*, 60*, 65*, 70* and 75°C*

Bathroom Controller:

37, 38, 39, 40, 41, 42, 43, 44, 45, 46, 47, 48°C

*Only for 60°C model

CASCADE INSTALLATION (ONLY FOR 26L MODEL)

- This type of installation allows two units to operate together by connecting two units with a 2-wire cable and some simple programming.
- The units will operate in a range between 25 MJ/h and 400 MJ/h when two units are connected together.
- Depending on water flow and desired temperature, the system can automatically operate or stop either or both units.
- Thermann genuine cascade cable can be used to connect the two units.
- The distance between the two units must be in the range of 50 - 1000 mm.
- Water and gas pipe length should be the same to both units. Otherwise the temperature of the hot water at the tap can be unstable.
- If connecting optional remote controllers, they must be connected to one unit only. That unit will need to be set up as the MASTER unit for the system to operate correctly.
- All fittings, valves and branch lines should be matched sets to each of the water heaters.

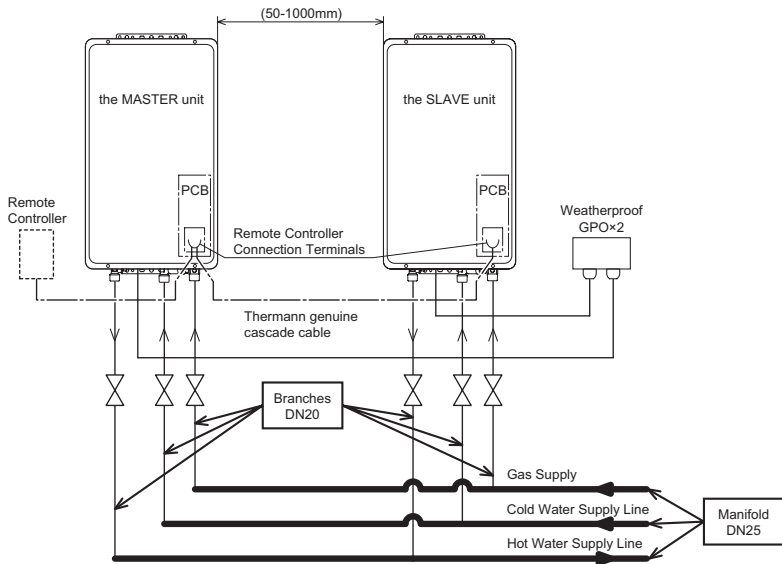

Recommendation

Manifold line size for cold, hot and gas pipes is DN25.

Branch line size for cold, hot and gas pipes is DN20.

(Refer to AS/NZS 5601 for gas pipe and AS/NZS 3500.4 for water pipe requirements).

CASCADE INSTALLATION (ONLY FOR 26L MODEL)

- To connect 3 remote controllers, two (small and large) cable clamps shall be used.

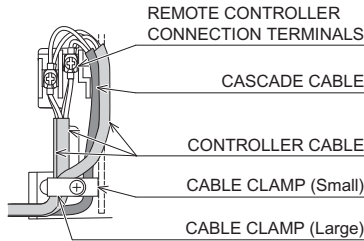

(Maximum Four Cables)

CASCADE SET UP

Do not supply power to either unit until steps 1-4 below are completed.

1. Connect pipes for gas, cold water and hot water.
2. Hook up the interconnect cable to the remote control terminal of each unit.
3. Set the Dip Switch 2 on the PCB of each unit as per the drawing and assign the MASTER unit and the SLAVE unit.

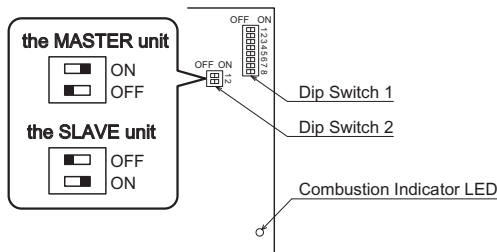

4. If connecting optional remote controllers, they must be connected to the unit which has been setup as the "MASTER unit".
5. Energize the SLAVE unit first. Then energize the MASTER unit.
6. If optional controllers are connected, follow initial setting of controllers on page 15 of this manual.
7. To verify setup is completed correctly, check remote controller digital display. If remote controller is not being used check combustion indicator LED on the PCB then follow the steps shown on the cascade installation flowchart.

CASCADE INSTALLATION FLOWCHART

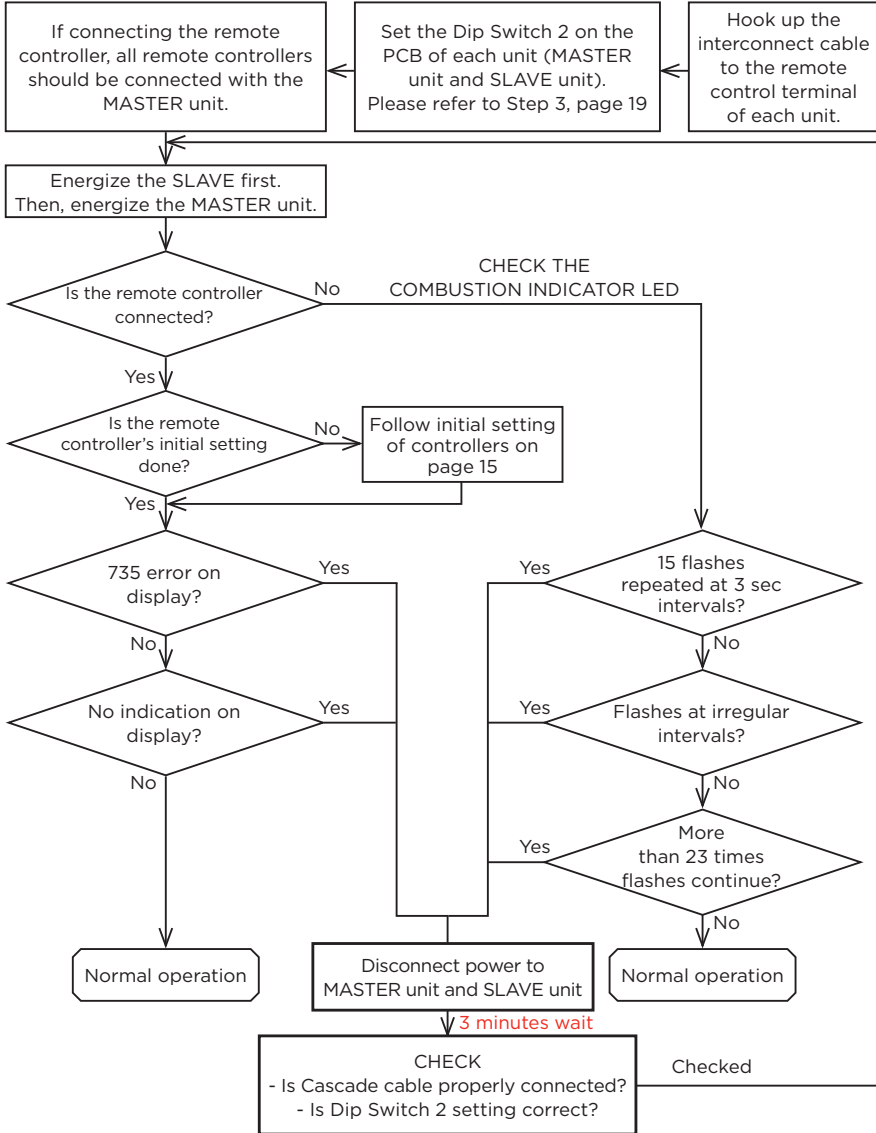

WIRING DIAGRAM AND REMOTE CONTROLS INSTALLATION SCHEMATIC

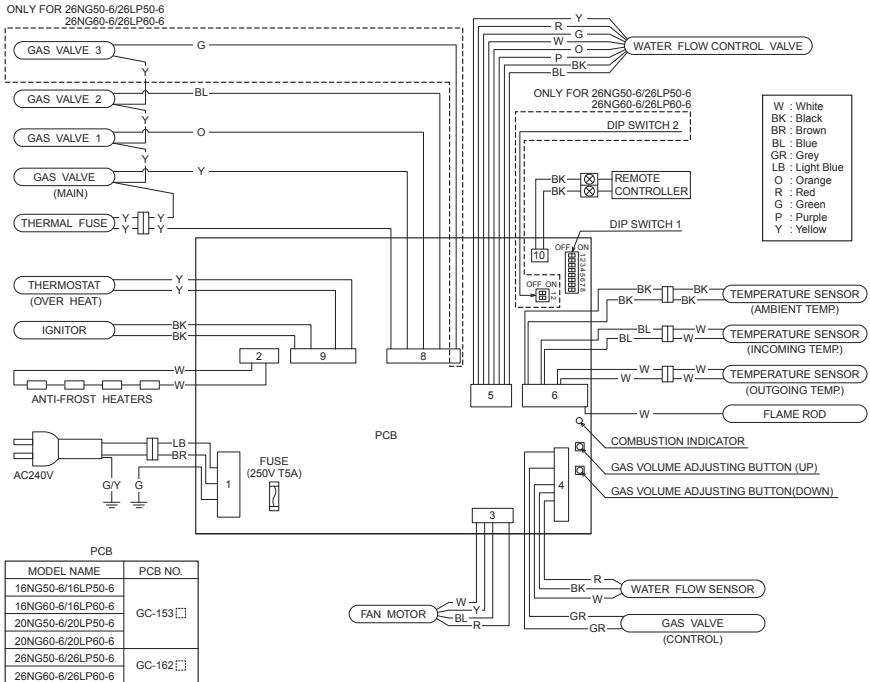

WIRING FROM MAIN UNIT TO KITCHEN & BATHROOM/ ENSUITE REMOTE CONTROLS

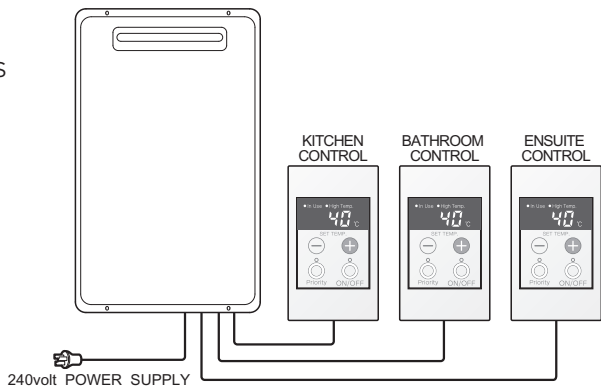

FAULT MONITOR

When installed with remote controllers the THERMANN HOT WATER UNIT HAS A SELF DIAGNOSING FUNCTION FOR FAULTS.

When the unit does not operate correctly an error code is displayed on the remote control TEMPERATURE DISPLAY INDICATOR.

The cause of the fault can be determined after checking the fault numbers display on the remote control display.

DISPLAY	PROBLEM	REMEDY
111	GAS BURNER FAILS TO IGNITE	CHECK GAS SUPPLY
121	LOSS OF COMBUSTION	CHECK GAS SUPPLY AND PRESSURE
141	RESIDUAL FLAME SAFETY DEVICE	CALL REECE CUSTOMER CARE 1800 080 055
311, 321, 341	THERMISTOR WIRE BREAKAGE	CALL REECE CUSTOMER CARE 1800 080 055
510, 511	GAS VALVE FAILURE	CALL REECE CUSTOMER CARE 1800 080 055
611	COMBUSTION FAN FAILURE	CALL REECE CUSTOMER CARE 1800 080 055
651	WATER FLOW CONTROL VALVE FAILURE	CALL REECE CUSTOMER CARE 1800 080 055
700, 731	PCB FAILURE	CALL REECE CUSTOMER CARE 1800 080 055
721	FALSE FLAME DETECTION	CALL REECE CUSTOMER CARE 1800 080 055
735	CASCADE COMMUNICATION FAILURE	CALL REECE CUSTOMER CARE 1800 080 055
740, 750, 760	COMMUNICATION FAILURE BETWEEN REMOTE CONTROLS AND PCB	TURN OFF POWER AND TURN ON AGAIN

