

Roca

IN-WASH® + IN-TANK® INSPIRA HS SMART TOILET FS BTW

Installation instructions

A803095H0R

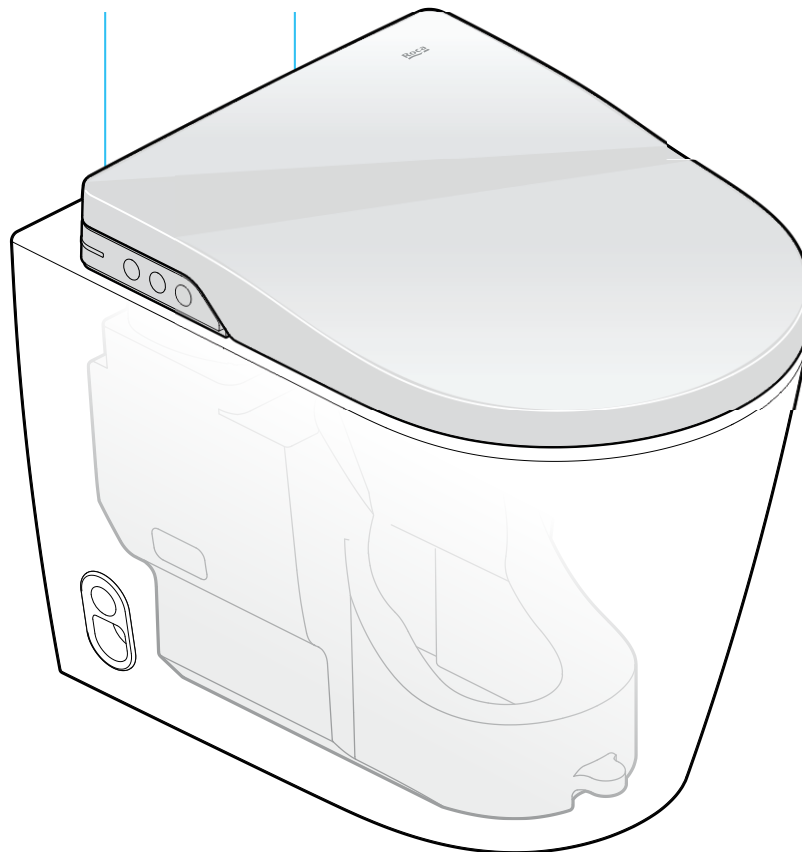

WARNING

KEEP OUT OF REACH OF CHILDREN.
THIS PRODUCT CONTAINS BUTTON BATTERIES.
Dispose of used batteries immediately. The battery is hazardous! If swallowed, a lithium battery can cause severe or fatal injuries within 2 hours. If you think batteries may have been swallowed or placed inside any part of the body, seek immediate medical attention. Contact the Australian Poison Information Hotline on 13 11 26 or National Poisons Centre NZ on 0800 764 766.



For commissioning, general installation & troubleshooting, refer to separate User Manual

Installer - Please ensure these installation instructions are left with the end user for future reference.

1. SAFETY

1.1 WARNING - PRECAUTIONS

Please read this manual carefully before using the product, and keep it at hand for future reference. A negligence or an incorrect use of the product can lead to serious injuries.

The product must be installed by a licensed electrician according to AS/NZS 3000 - Australian wiring rules

The appliance is not to be used by persons (including children) with reduced physical, sensory or mental capabilities, or lack of experience and knowledge, unless they have been given supervision or instruction. Cleaning and maintenance to be carried out by the user must not be carried out by children without supervision.

If the supply cord is damaged, it must be replaced by the manufacturer, its service agent or a similarly qualified person in order to avoid a hazard.

When using electric devices, basic safety measures should always be followed; make sure you take into account the following:

1.1.1 GENERAL WARNINGS

Regarding the packaging:

- The packaging of the **In-Wash + In-Tank** is not a toy.
- Do not allow children to play with the plastic bags or with the packaging material as they may present a risk of suffocation or injuries. Keep therefore the material in a safe place or get rid of it following the environmental rules.

Regarding the remote:

WARNING!

KEEP OUT OF REACH OF CHILDREN. THIS PRODUCT CONTAINS BUTTON BATTERIES.

Dispose of used batteries immediately. The battery is hazardous! If swallowed, a lithium battery can cause severe or fatal injuries within 2 hours. If you think batteries may have been swallowed or placed inside any part of the body, seek immediate medical attention. **Contact the Australian Poison Information Hotline on 13 11 26 or National Poisons Centre NZ on 0800 764 766.**

- Keep new and used batteries away from children.
- If the batteries compartment does not close securely, stop using the product and keep it away from children.

Regarding the anal and perineal cleaning:

- Do not use the device beyond the time established in each cycle. If you do it, you may be altering your body's natural balance.
- Individuals undergoing medical treatment or therapy in these specific areas should consult with their physician before using this type of product.

Regarding the seat and cover:

- Soft-close seat and cover.
- The dampers in the seat and cover provide slow and silent closure. Do not force the seat down as this can result in damage to soft close dampers.

1.1.2 INSTALLATION PRECAUTIONS

This product should only be installed by suitably qualified and licensed personnel using only components provided with this product. Please check the installation manual in order to obtain more information on the electrical and water connections.

Make sure you fulfil the following precautions regarding the hydraulic installation:

- The appliance needs to be connected to the main water valve using new hose sets. Old sets should not be reused.

- Always connect the **In-Wash + In-Tank** to the domestic cold water mains.
- Rain water, demineralized water, sea water or grey water are not suitable to operate this equipment. The **In-Wash + In-Tank** shower toilet may only be operated with normal drinking water.
- When installing the water filter, make sure it is tightened adequately and in its correct position.
- The pressure of the water supply of this device should be within the range of 150Kpa to 500 Kpa.

Make sure you fulfil the following precautions regarding the electrical installation:

- Always isolate the power cable before handling the product.
- Always use the specified supply voltage (220-240V, AC 50-60Hz). The product should have an earth connection. It is necessary to install a circuit breaker.
- Do not use a poor or defective electrical connection.
- Remove the dust from the power outlet.
- Do not bend or squeeze the connecting tube or the power cable; and keep the cable away from humid, hot or sharp surfaces.
- Do not install the product in wheeled vehicles or boats.

Ignoring these precautions may cause fire, electric shock, short-circuit or damages to the device.

To confirm that the installation is correct:

- Check that the vitreous china piece is installed according to the provided installation manual.
- Check that the shut-off valve is open.
- Check that the power supply is connected to the **In-Wash + In-Tank**.
- Check that the remote control is connected to the **In-Wash + In-Tank**. (Should this not be the case, please see section 2.2.1).

When the **In-Wash + In-Tank** is connected to the power supply, the lights blink and a long beep may be heard.

The nozzle moves outwards and inwards.

The lights switch off and the **In-Wash + In-Tank** remains in a Stand-by mode, ready to be used.

1.1.3 PRECAUTIONS FOR USE

These precautions are important for a safe use. Make sure you follow them and use the product properly.

The **In-Wash + In-Tank** is a WC that has been designed for the cleaning of the anal and perineal areas. It has been designed mainly for private use. Its use is restricted to enclosed spaces. Any other use will not be deemed in accordance with its purpose and Roca will not accept any responsibility for the consequences that might arise from an improper use.

Should there be an operational failure, please check the Problem resolution chart (see section 5).

To lean back when you are sitting on the **In-Wash + In-Tank** will facilitate the adjustment of the nozzle and will reduce possible splashing.

Do not urinate or splash water or cleaning agents on the main body or the mains plug.

If you do it, you may cause a fire, electric shock, heat or a short-circuit and you may cause stains or a malfunction.

Do not ever obstruct any opening in the product, nor should you drop or insert any objects in them. Keep the air inlet free of lint.

Do not place any open flames, candles, cigarettes or similar items over the product and do not drop flammable items or cigarettes near or inside the product.

Do not step on the product.

Avoid forcing the seat or the cover.

Please do not bend, pull or twist the power cable, nor should you place heavy objects on it.

If there is a water leak, always close the shut-off valve.

Do not use a booster seat for children or adults if you are going to use the **In-Wash + In-Tank**.

To avoid dropping the remote control, place it on its base when you are not using it.

1.1.4 MAINTENANCE PRECAUTIONS

Turn off the product if you are not going to use it for a long period of time. (Check section 3.6 of this manual).

Do not disassemble or repair the product; please contact Technical Assistance in case of breakdown. Any repairs should be carried out by authorised staff, using original spare parts and accessories.

When you use cleaning agents to clean the WC, clean it and remove it in 3 minutes, leaving the seat and cover always open.

Clean any remains of detergent from the WC bowl. (If the vapour from a WC cleanser enters the main unit, it may cause a malfunction).

1.2 ENVIRONMENTAL CONDITIONS

The room temperature should not be below 4°C or over 40°C.

When the room temperature drops below 4°C, avoid damages due to freezing; frozen water pipes could break the **In-Wash + In-Tank** and the pipes, resulting in a water leak; regulate the room temperature to prevent the pipes and hoses from freezing during the cold months.

- The product must be installed by a licensed electrician according to AS/NZS 3000 - Australian wiring rules.
- This product must be installed by a licensed plumber according to AS/NZS 3500 and all local regulations.
- Before installation, read this installation manual thoroughly and the included safety precautions. Parts must be installed according to the instructions.
- Do not damage electrical connection components.
- The recommended water supply pressure is 150 KPa to 500 KPa. Operate equipment within the recommended water pressure.
- Water supply temperature must be between 10 - 30°C. Ensure the correct water temperature is maintained.
- Do not use a water supply hose other than the one provided with this product.
- Make sure that this product is correctly earthed to ground. (If the product is not earth-connected, there is a risk of electric shock).
- **Please note that this product has an Integral High Hazard Backflow Prevention device that meets the requirements outlined in AS/NZS 3500.1 and WMTS 051. IN-WASH integral Bi-det Douche seat includes air gap assessed and found to comply with the requirements of AS2845.2:2010. Tested and complies with AS 2845.2:1996 Appendix A Backsiphonage Test Air Gaps.**

Technical information	
Power Supply	220-240Vac 50-60Hz
Power Wattage	1700 W
IP Rating	IPX4
Note: Any electrical work connected on this project must be installed by qualified personnel, in accordance with AS/NZS 3000 Wiring Rules.	
Certification	
Watermark	AS1172.1/AS1172.2 Certificate No. WMKA02321
WELS	4 Star, 4.5/3 litre, Average Flush 3.3 litre
RCM	

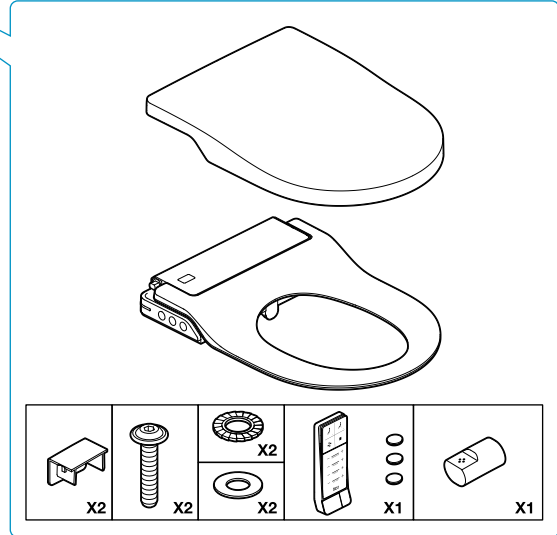
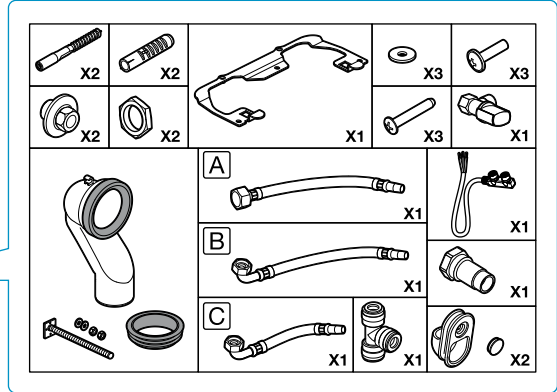
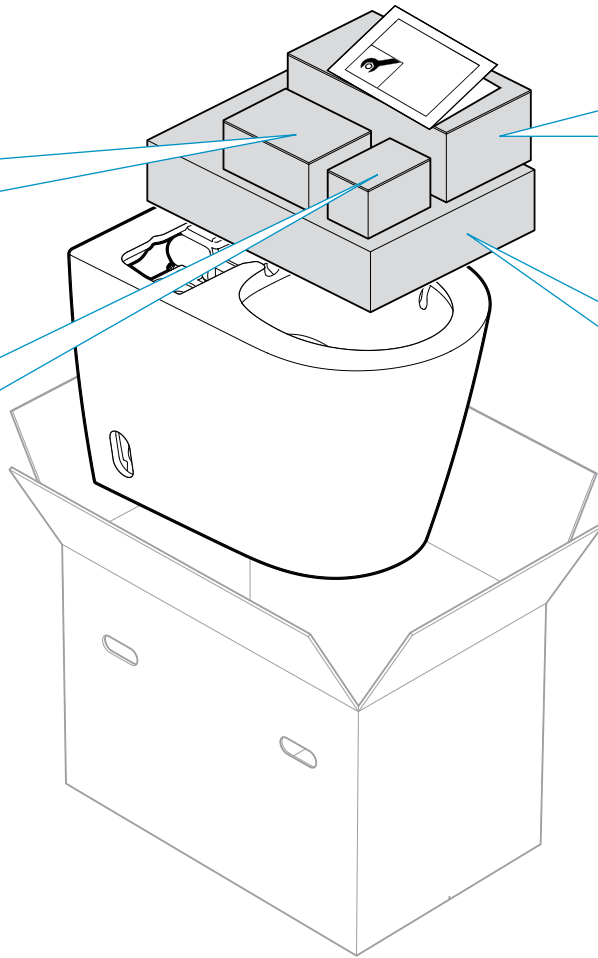
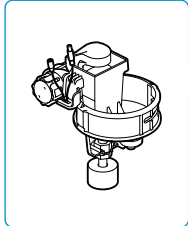
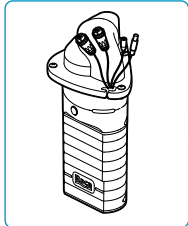

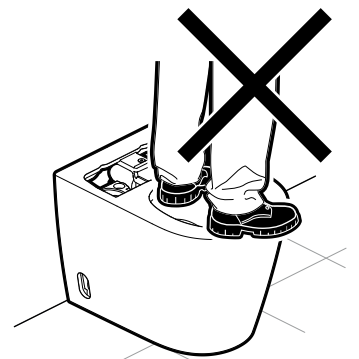
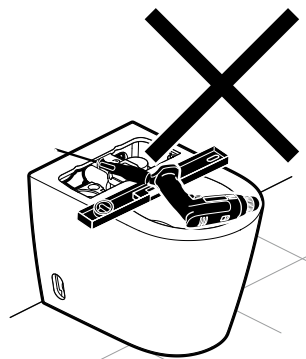
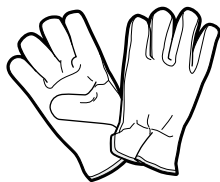
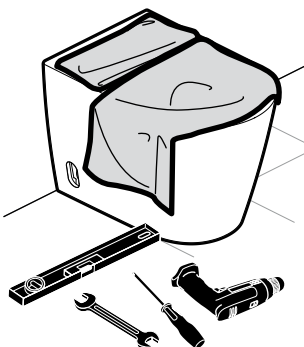
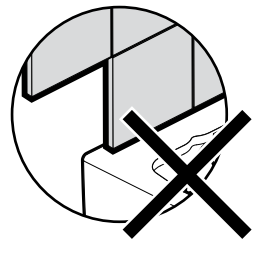
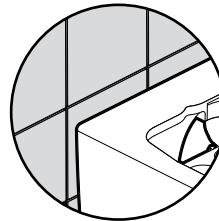
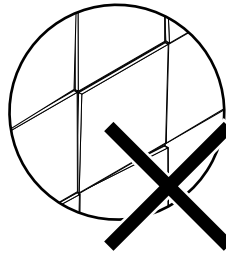
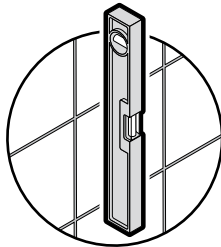
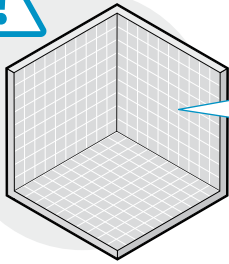
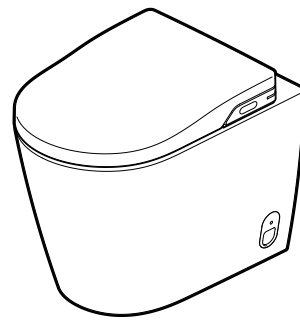
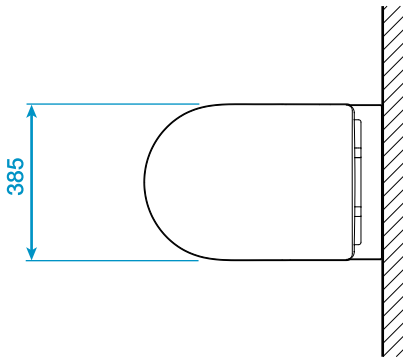
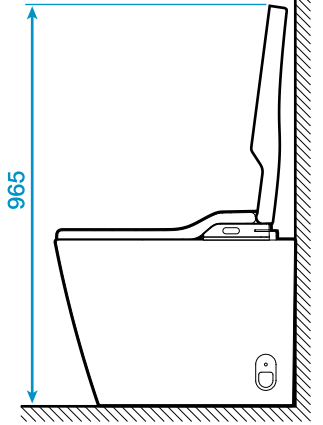
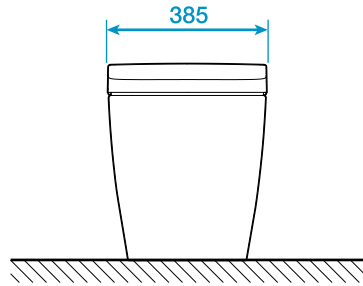
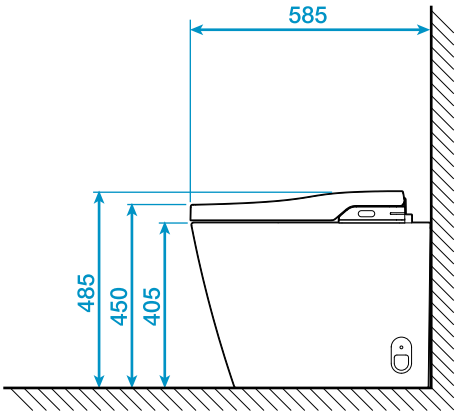



Alternative drainage connection

Alternative optional bends for different rough in need to be ordered separately.

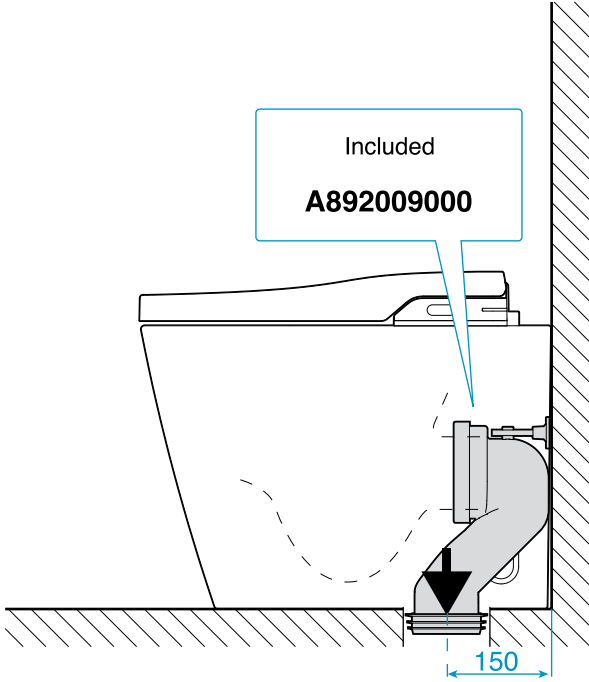

Optional

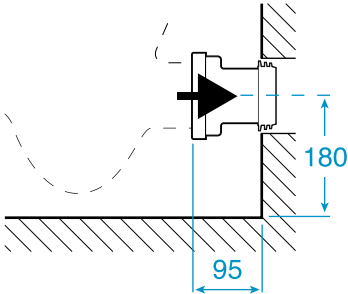

A892018000

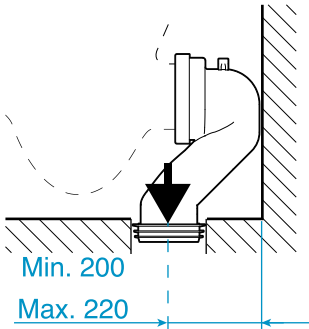

A892009010

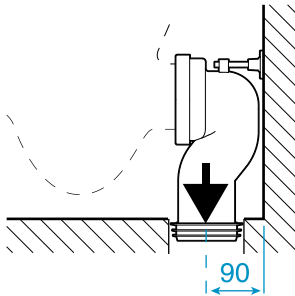

A526505414

1 Water Supply Connection



Option

1a

Option

1b

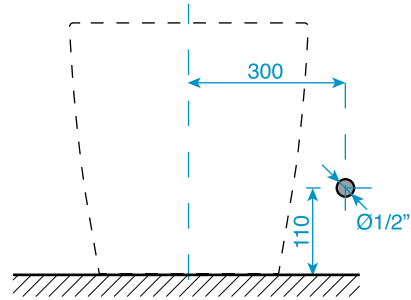
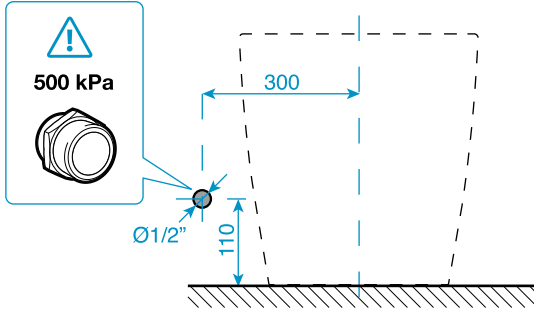

2 Electrical

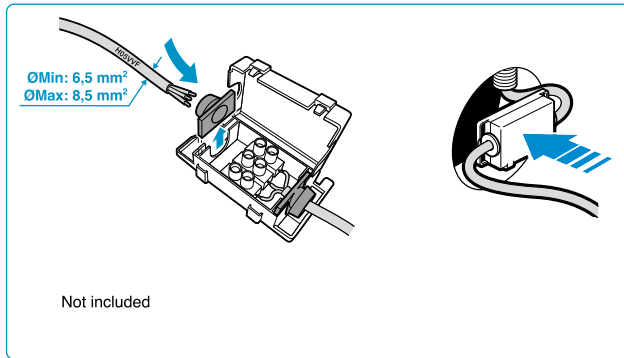

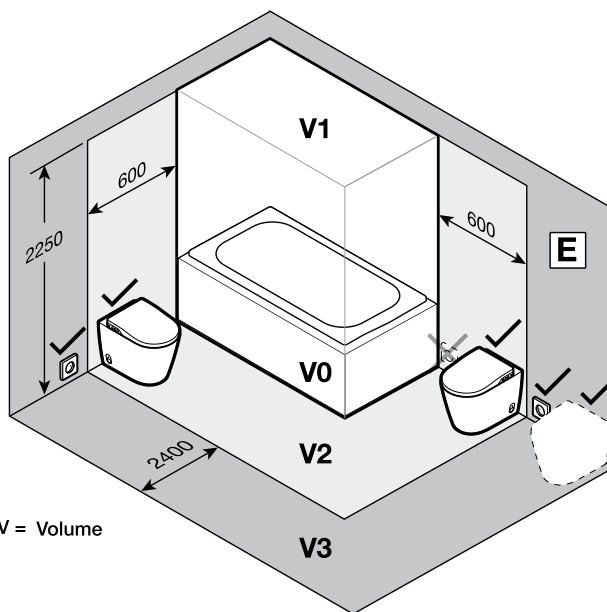
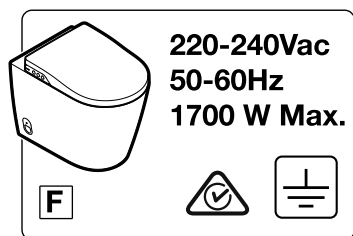
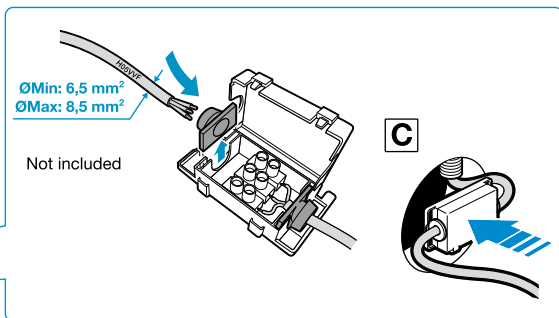
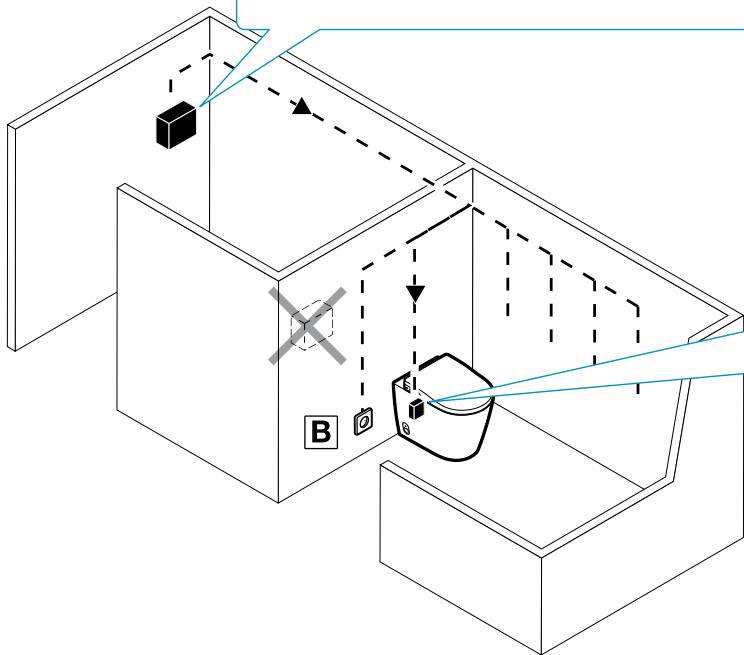
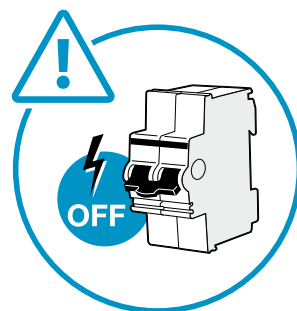
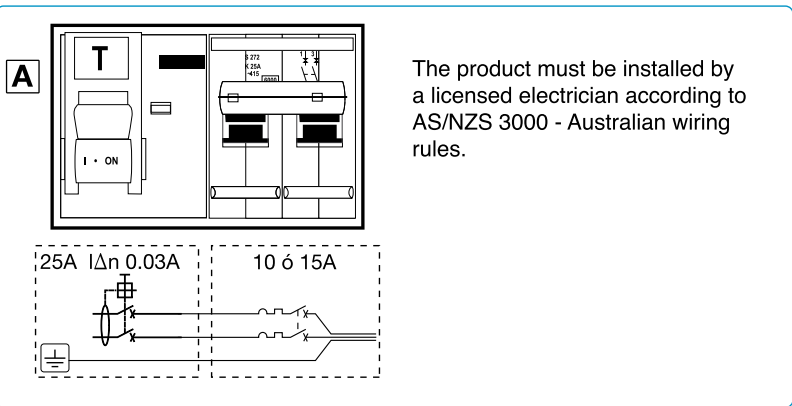
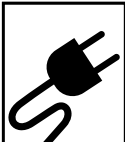

A The electrical installation must be protected by means of a IΔn 0,03A and 25A RBCO and a circuit breaker of 10 or 15A. Both switches must be placed outside the bathroom.

B The power connection of this product must be permanently connected to a fixed electricity line. Placement of a plug is not acceptable.

C In the case of an internal connection, an IPX4 terminal strip (not supplied) must be used for connection to the mains, with a minimum 1mm² section cable.

D The range of function of the WC is 220-240Vac, 50-60Hz

E Neither component nor connection of the WC must be operated.

No electrical device must be introduced inside the WC.



1

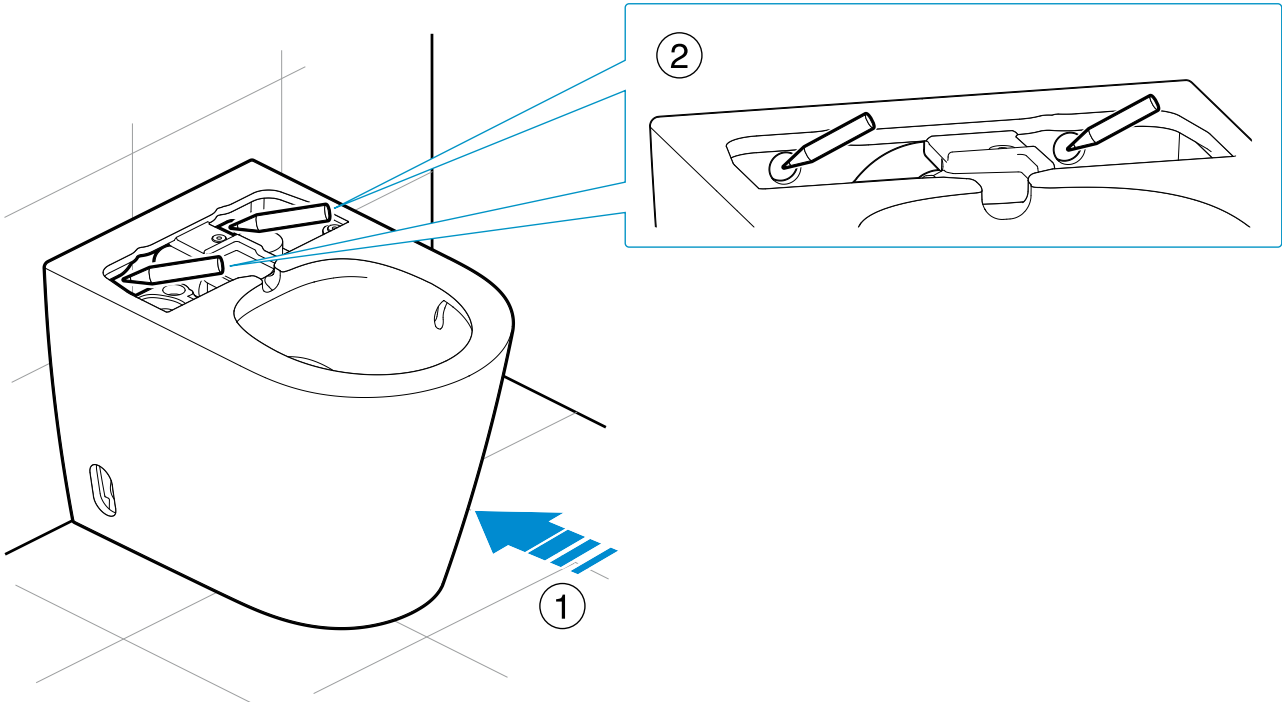

2

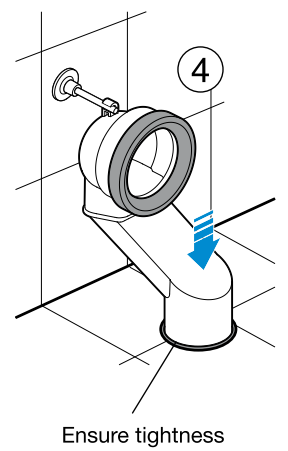
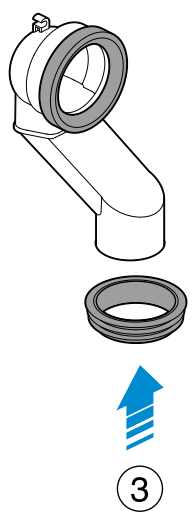
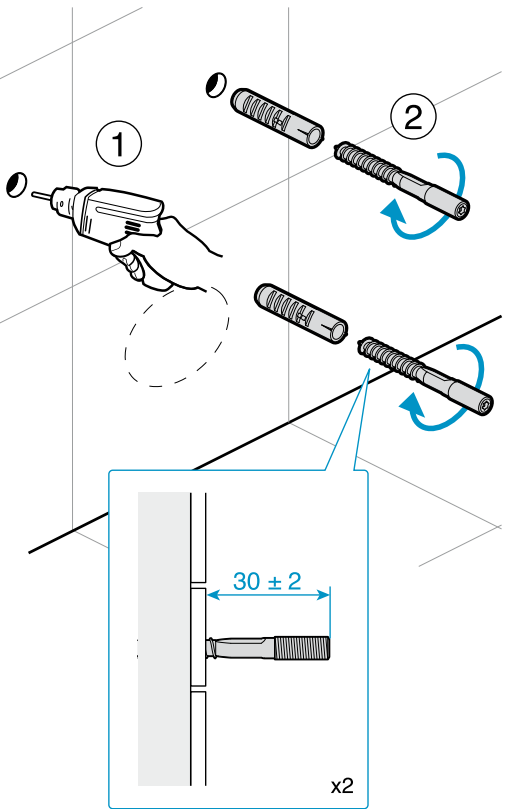
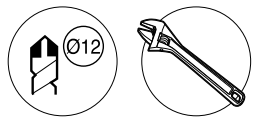

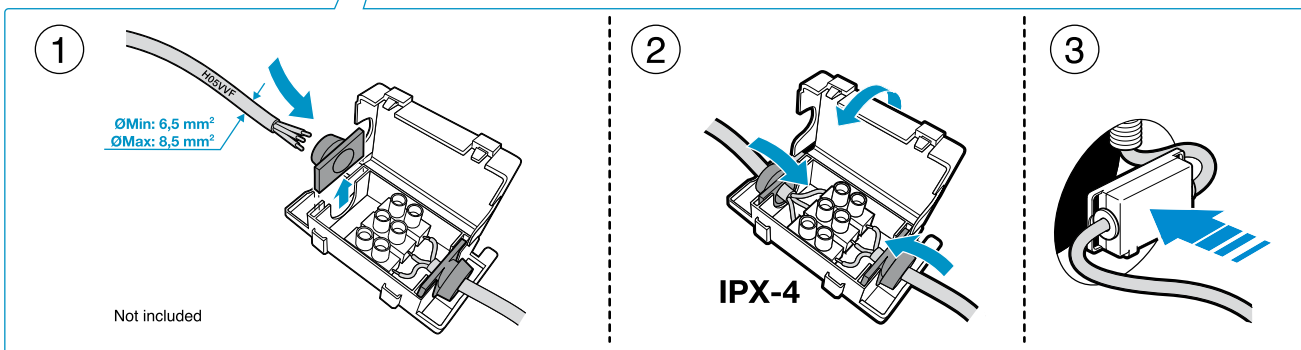
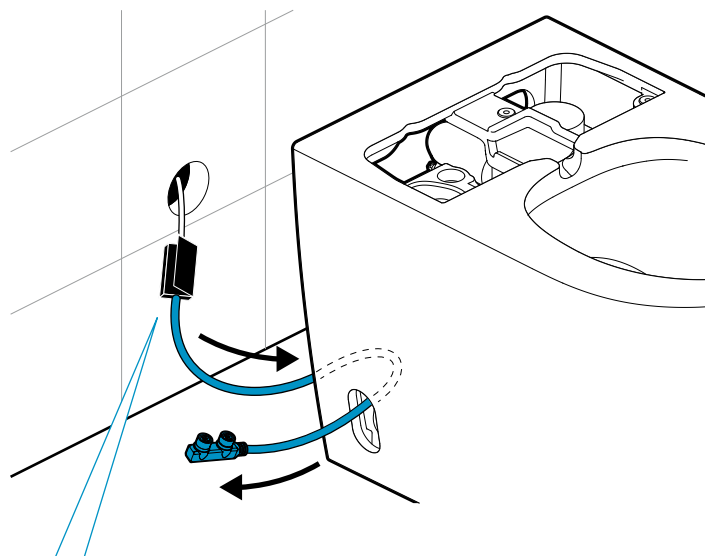

Pipes

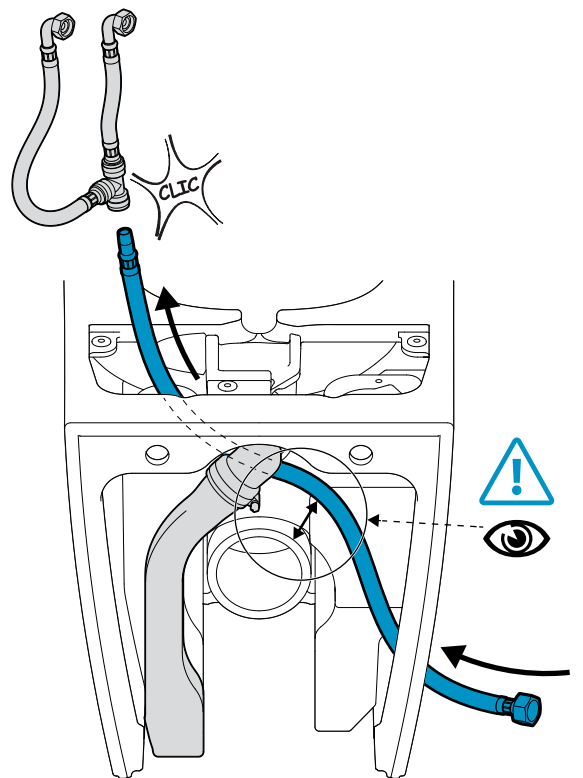
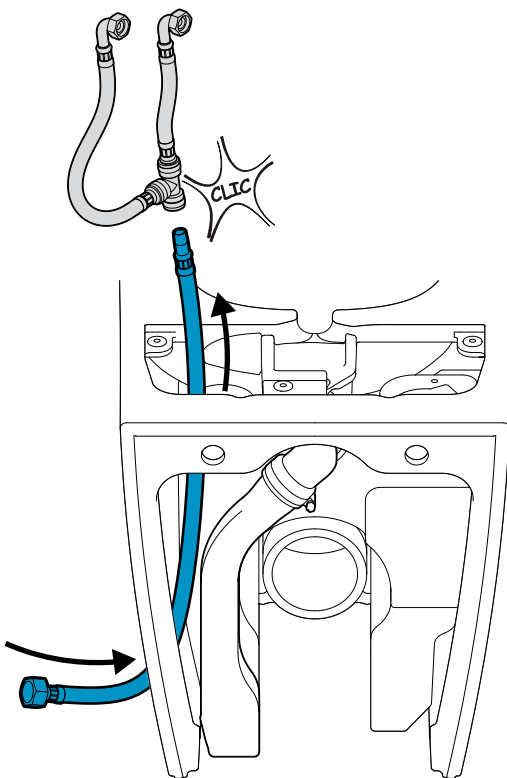
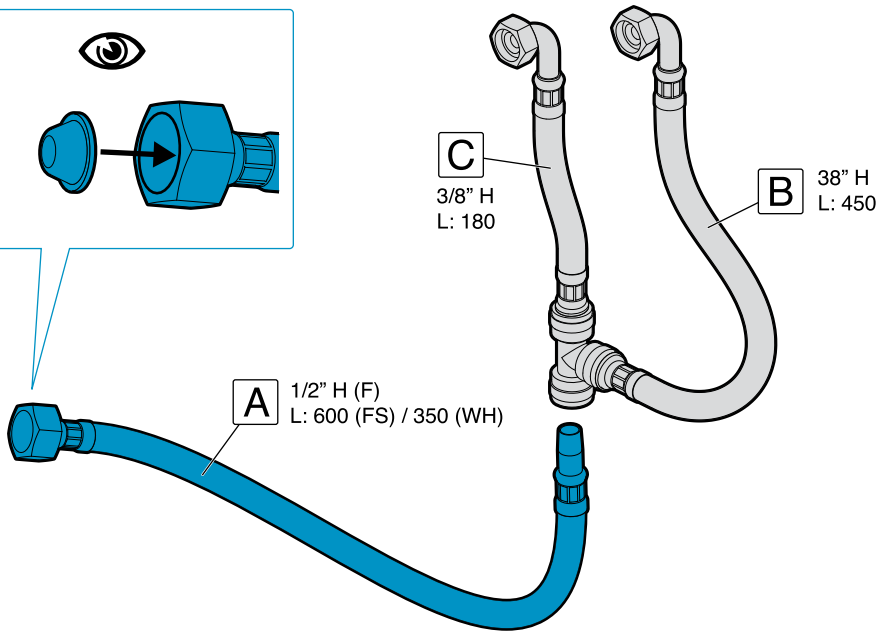
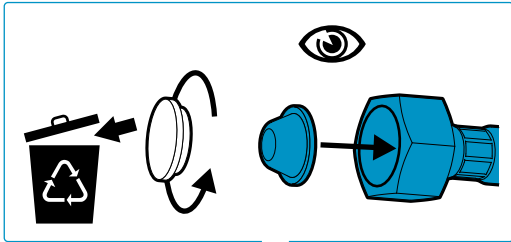
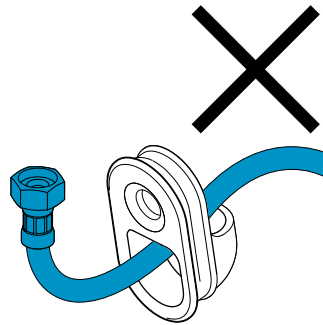
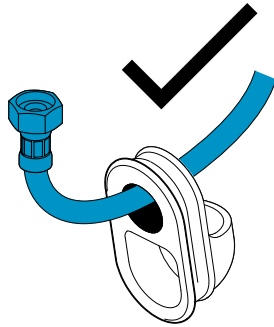

5

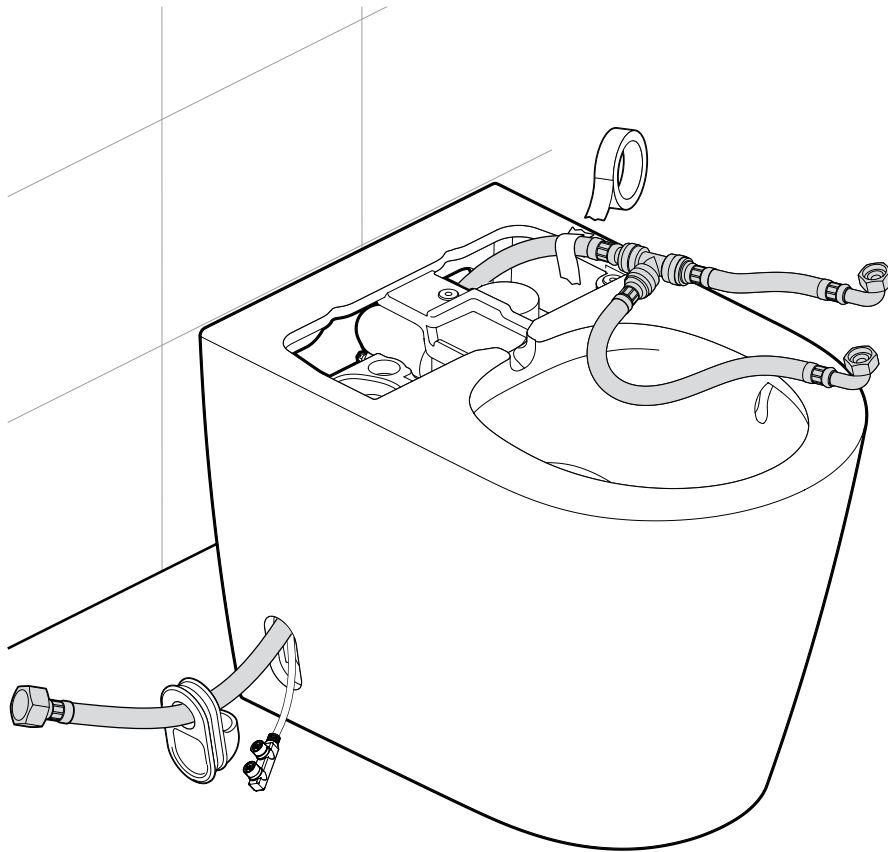

6

1

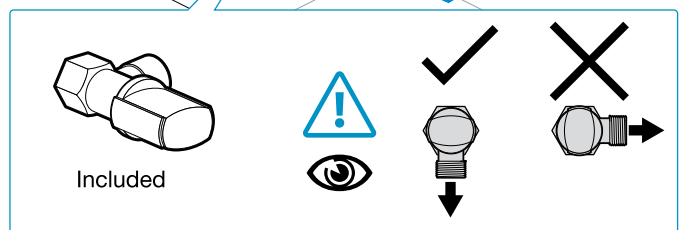
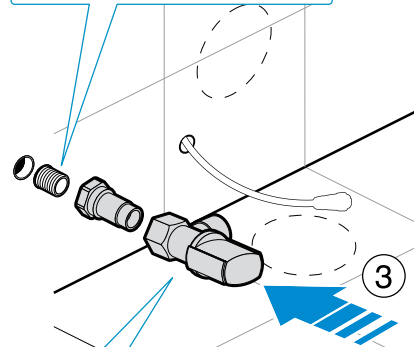
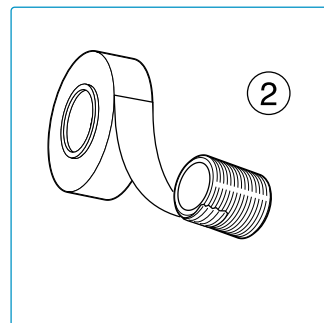

Note: Dual check valve must be fitted before cistern stop.

7

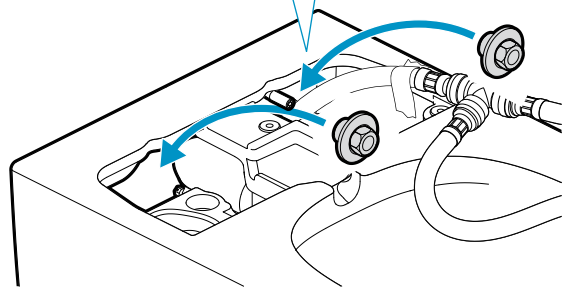
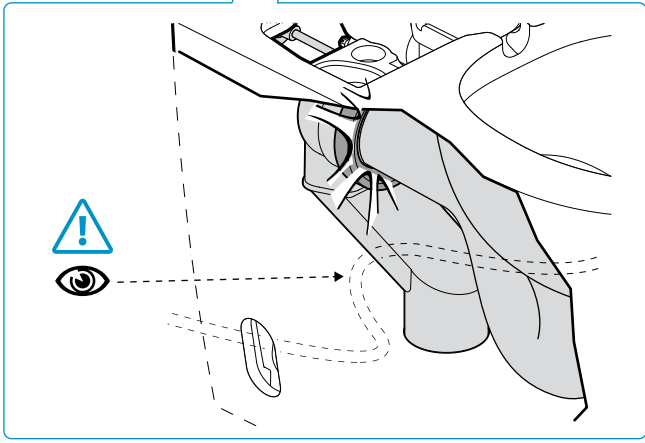
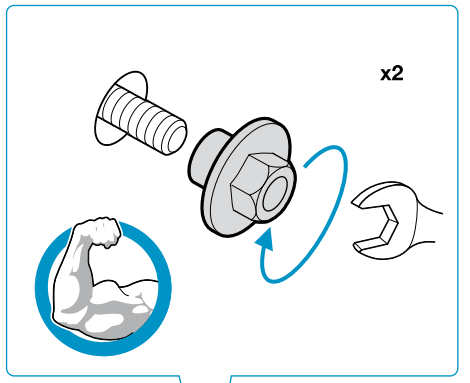
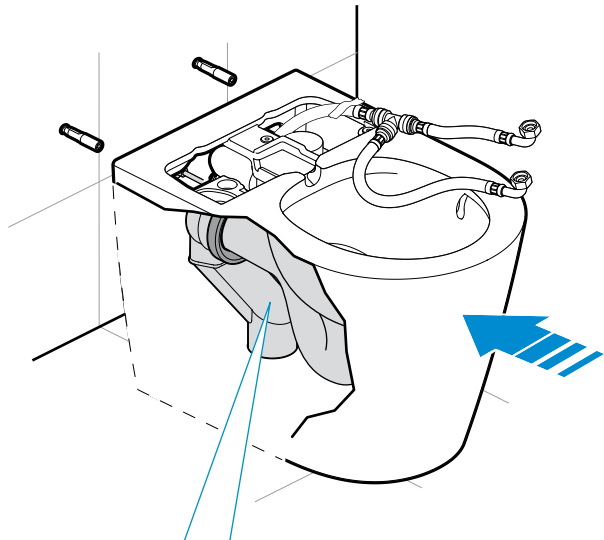

8

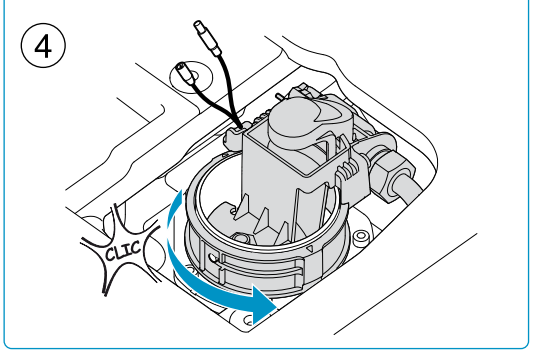
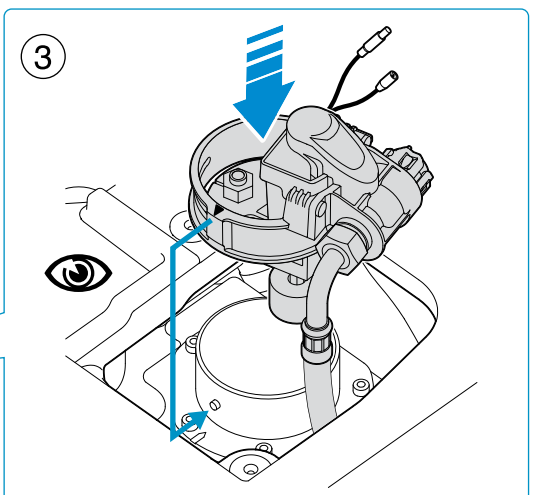
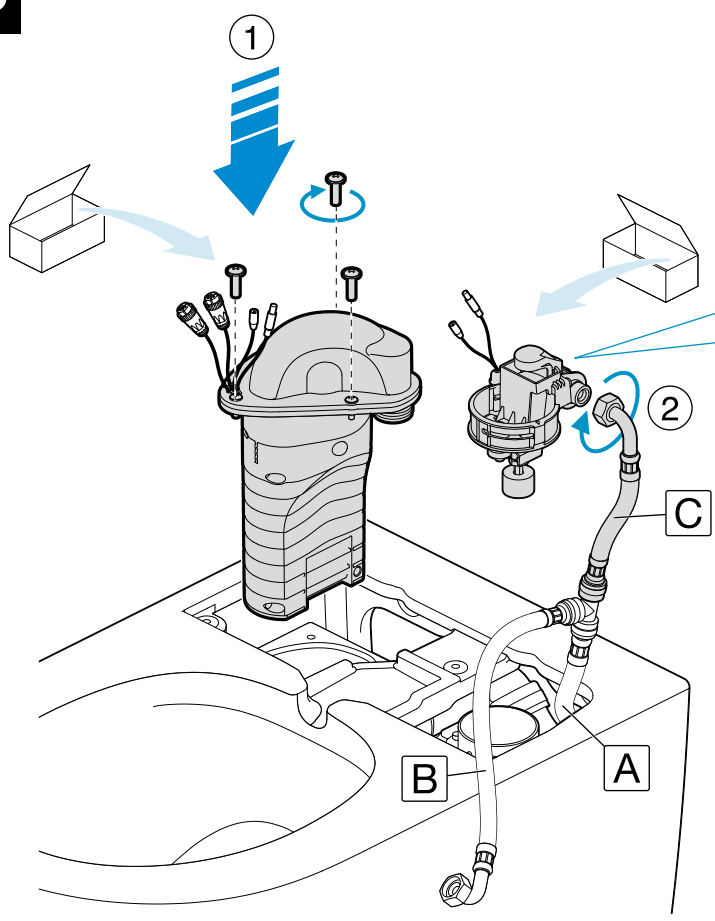

9

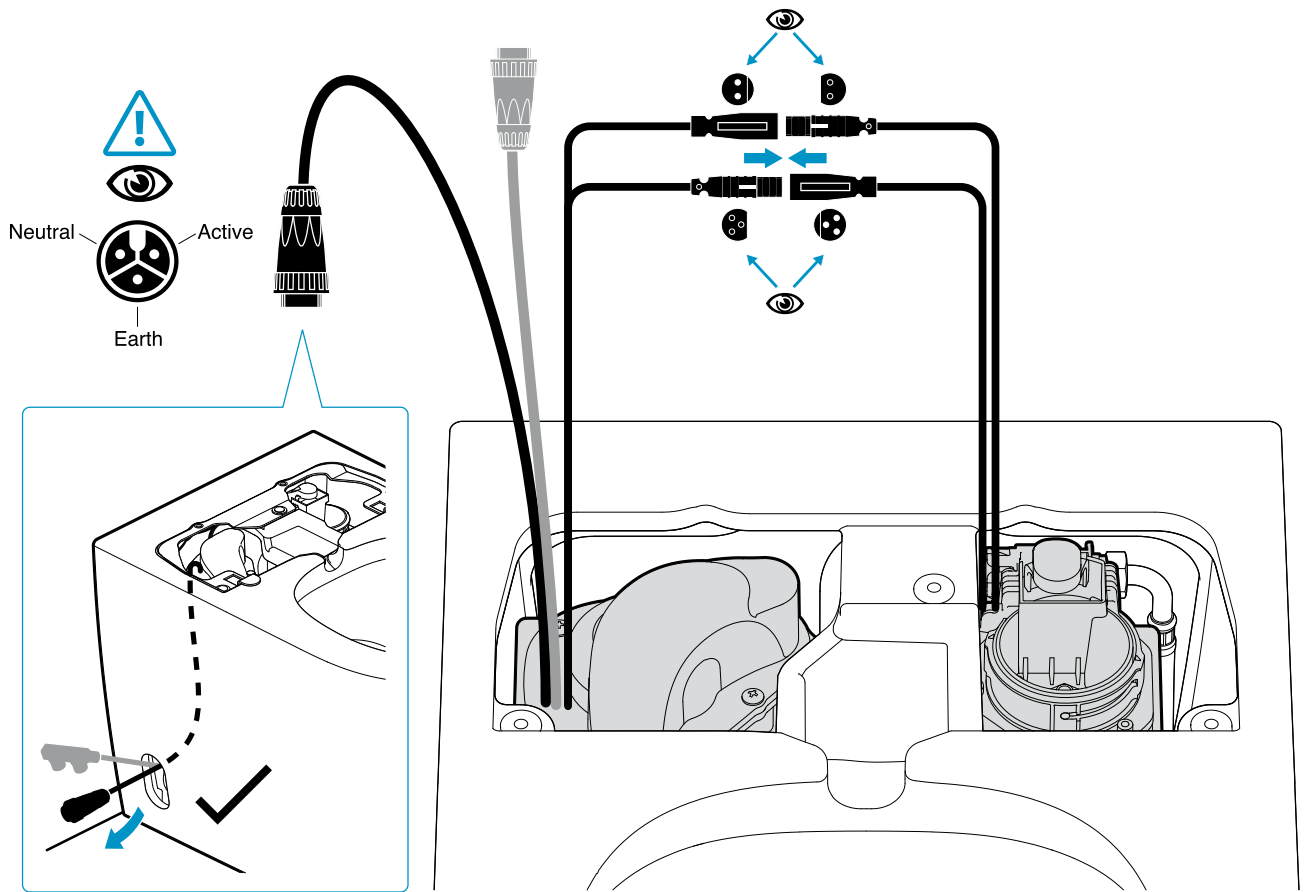

10

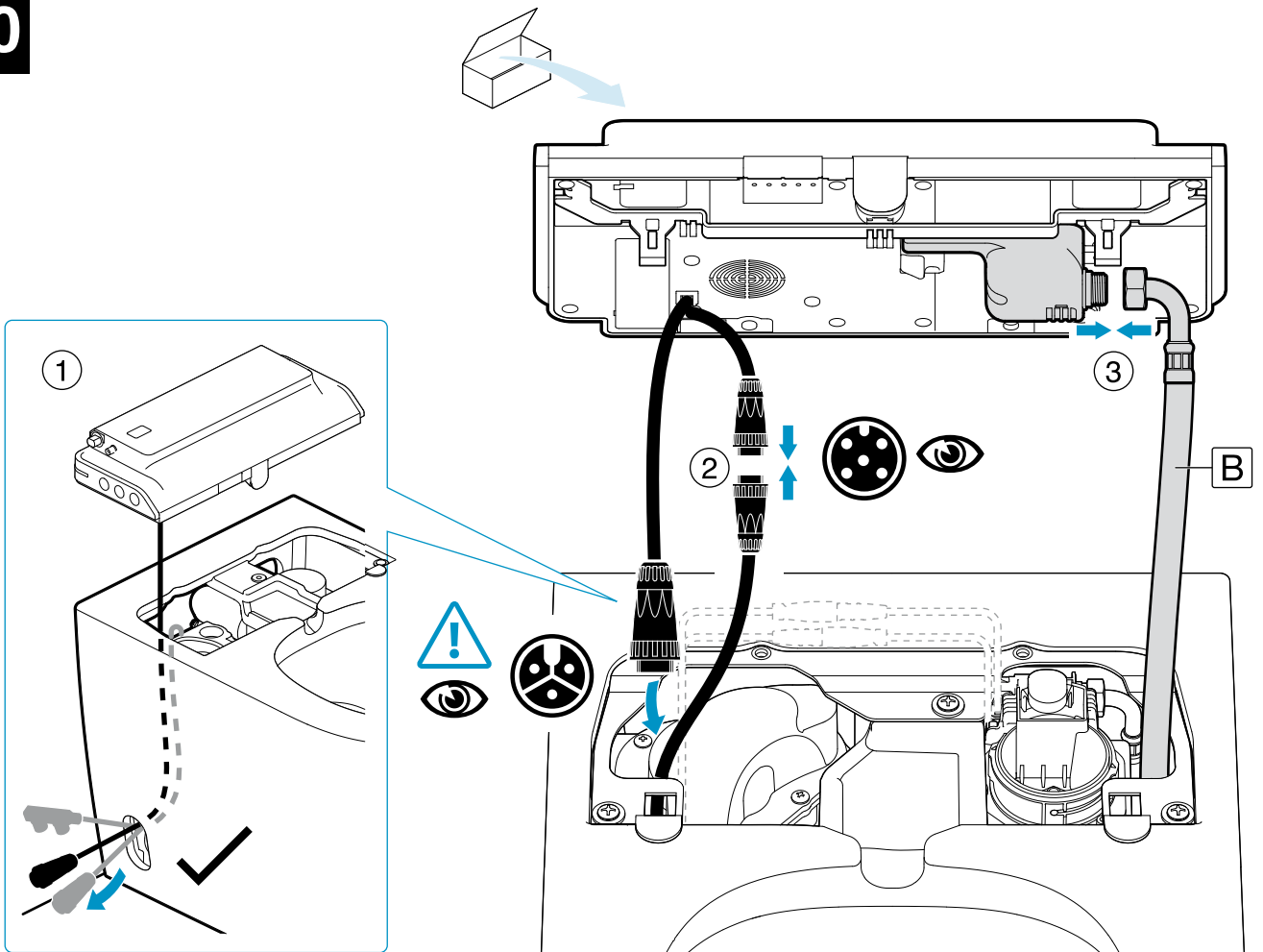

11

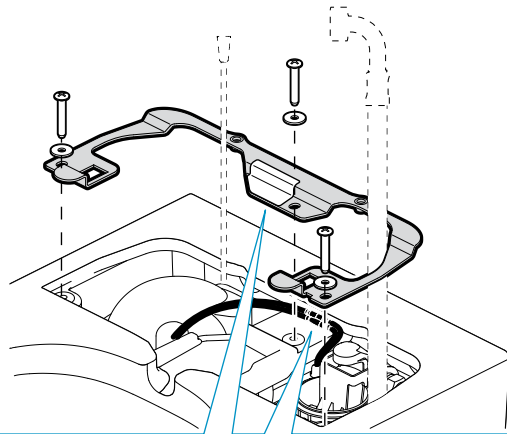

CAREFULLY FIT ASSEMBLED
WIRE / CONNECTOR UNDER
BRACKET

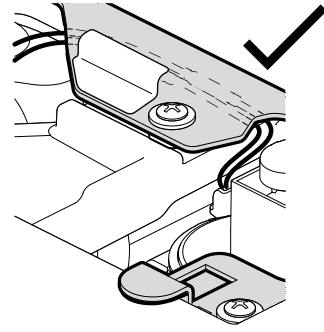
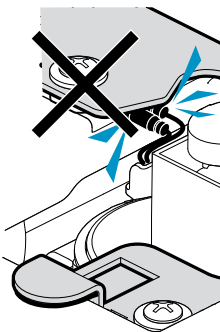
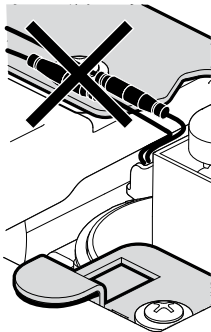
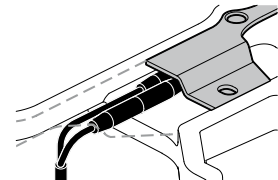
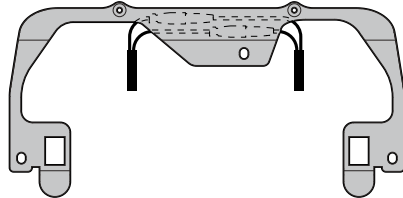

12

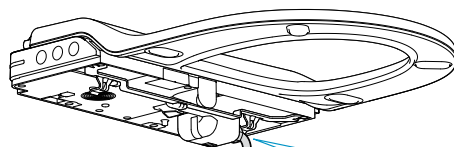
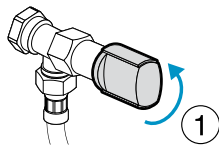

2

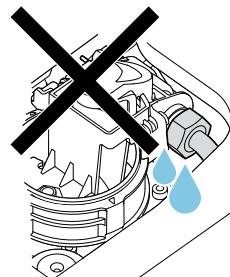
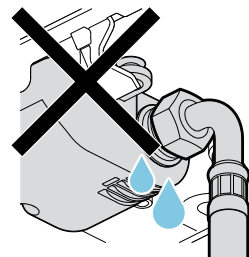

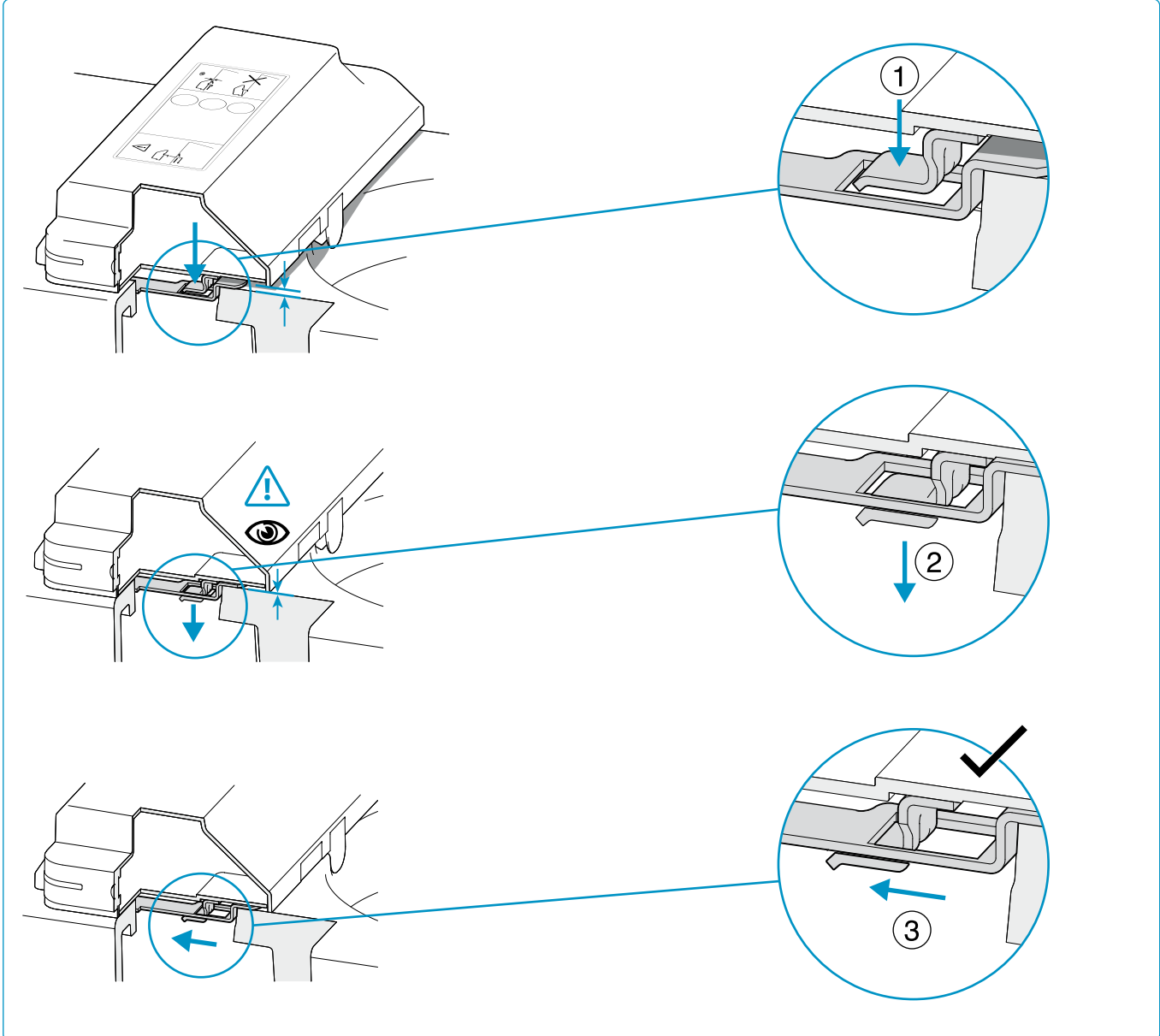
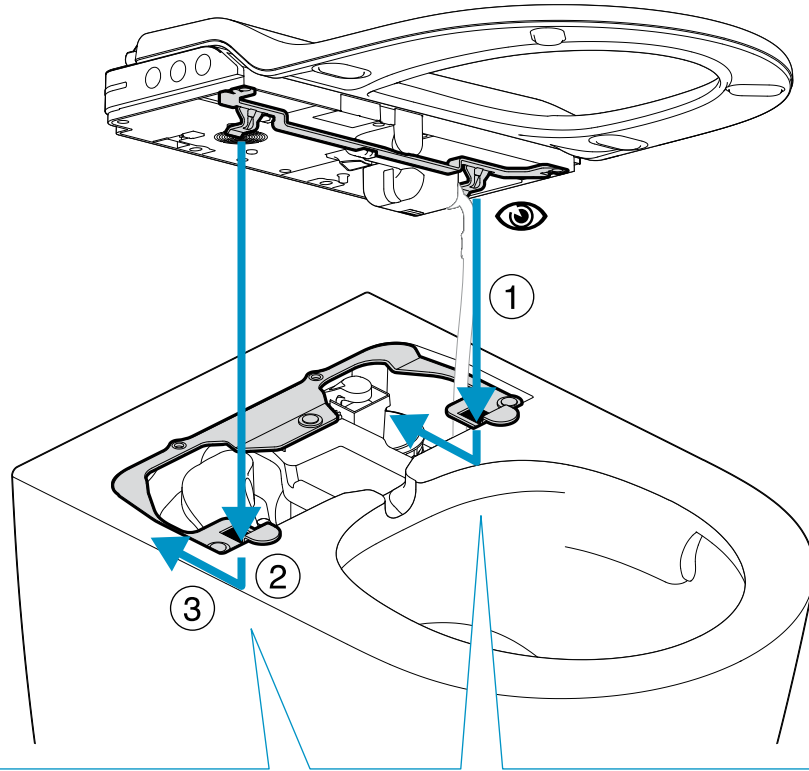

14

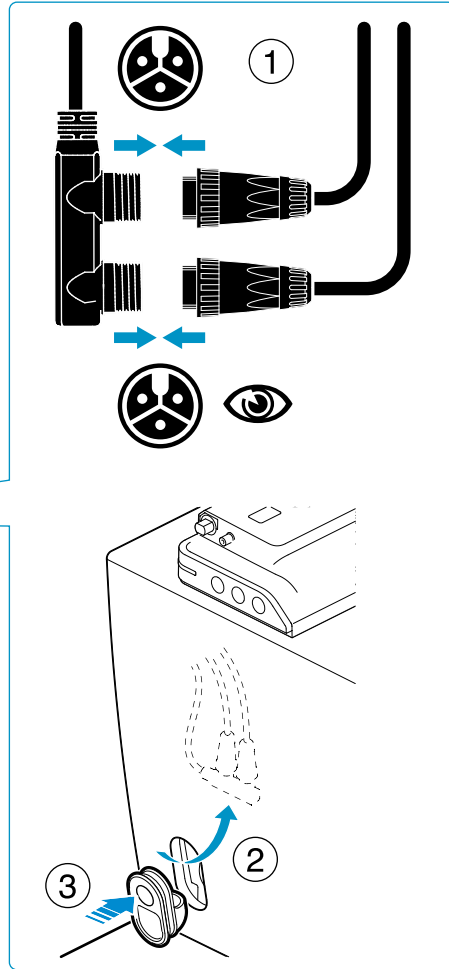
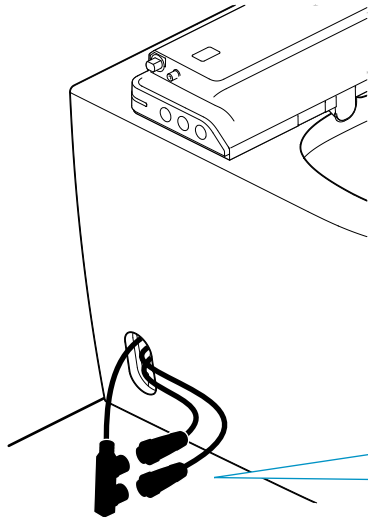

15

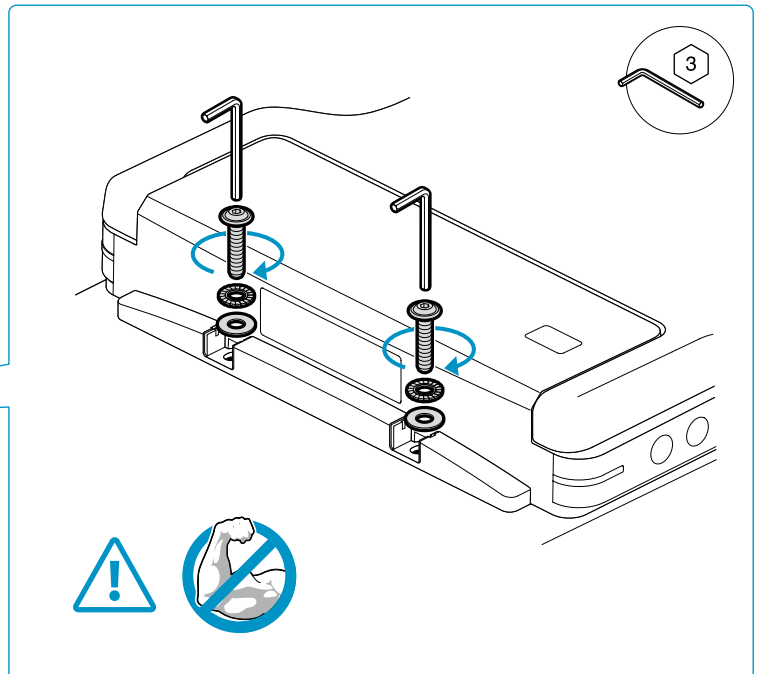
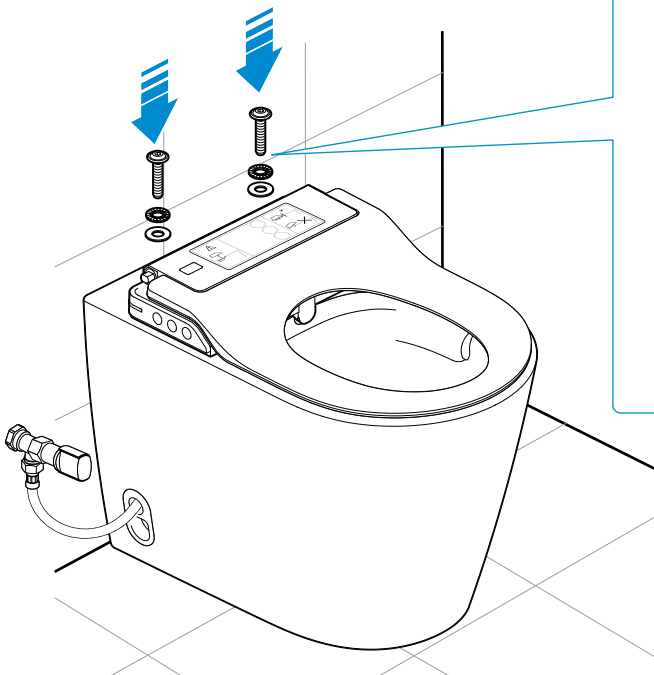

16

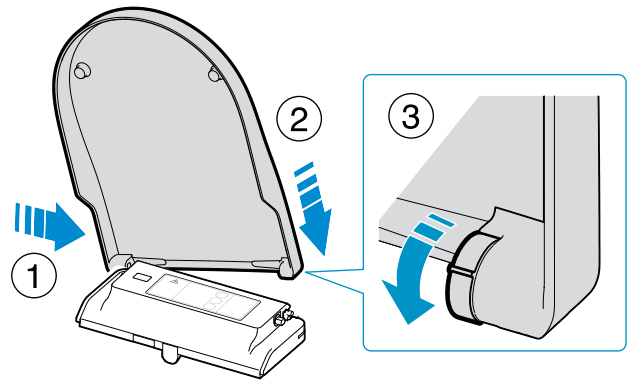
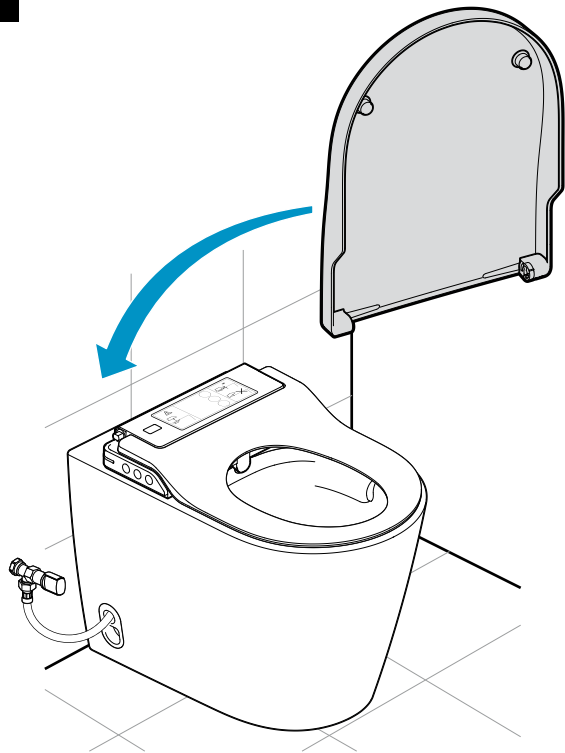

17

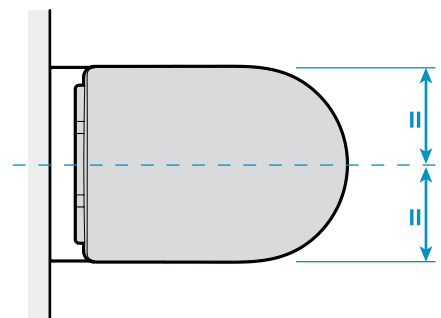
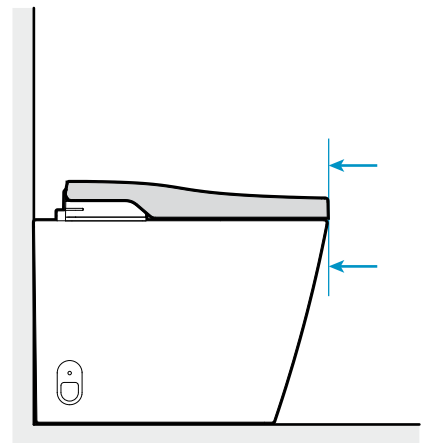
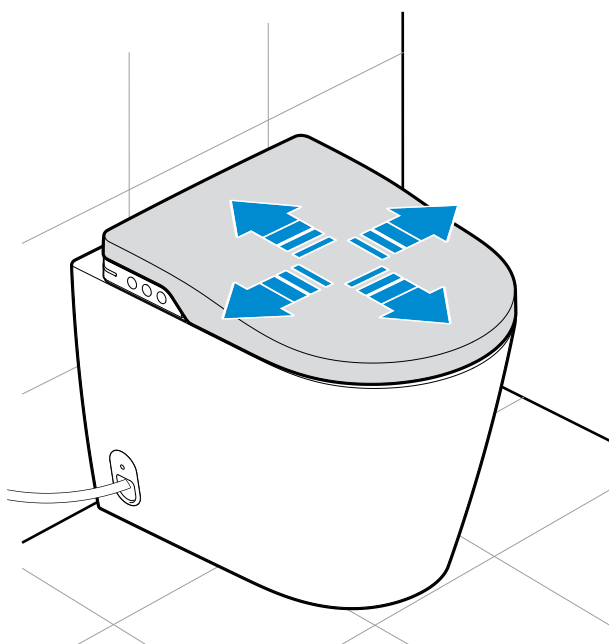

18

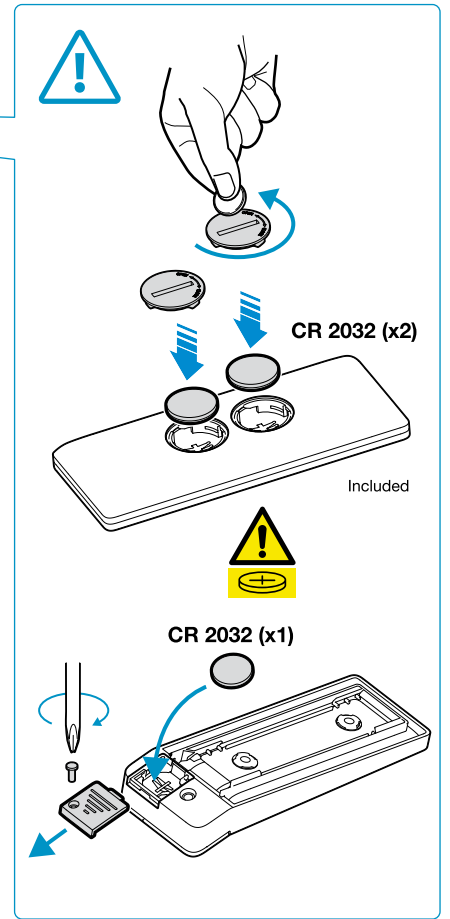
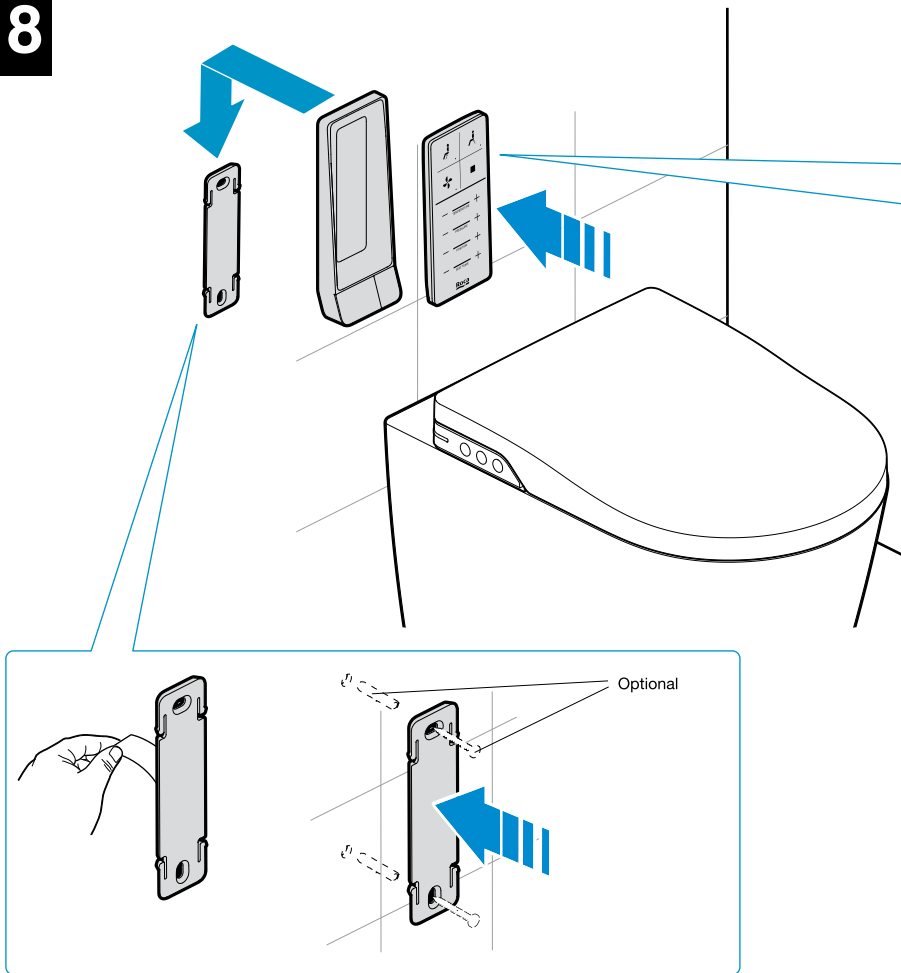

19

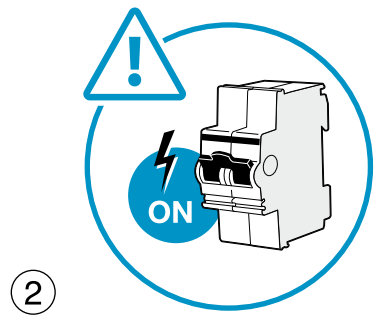
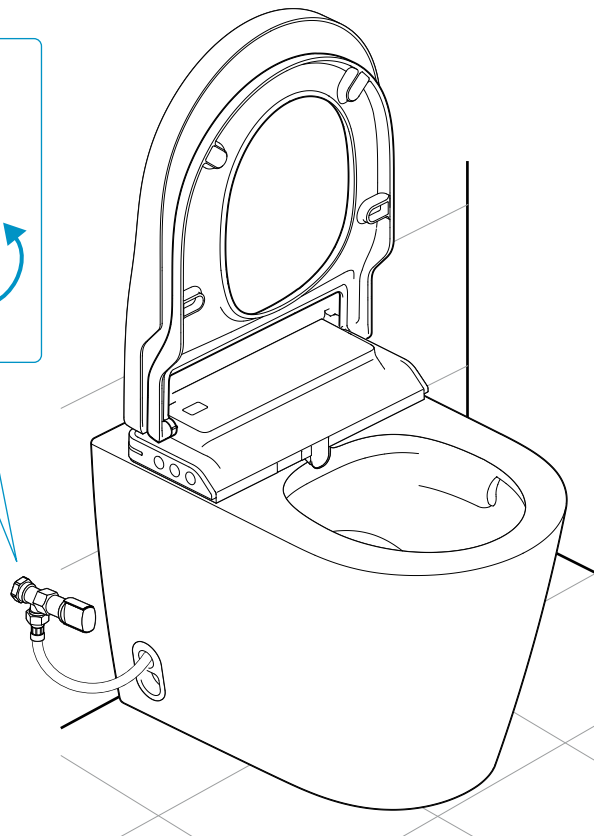
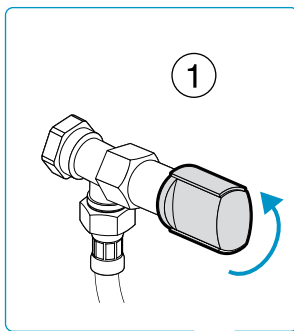

20

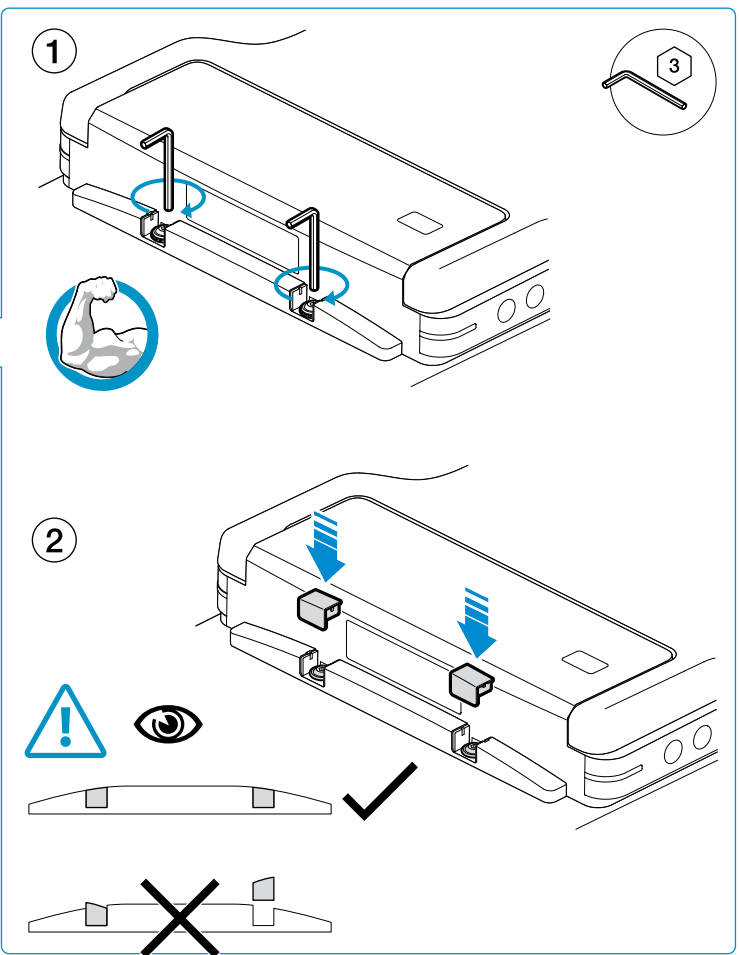
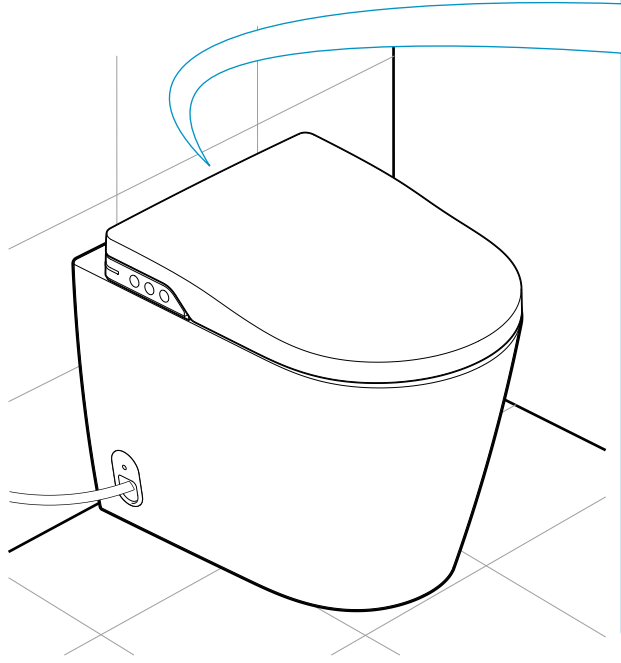

21

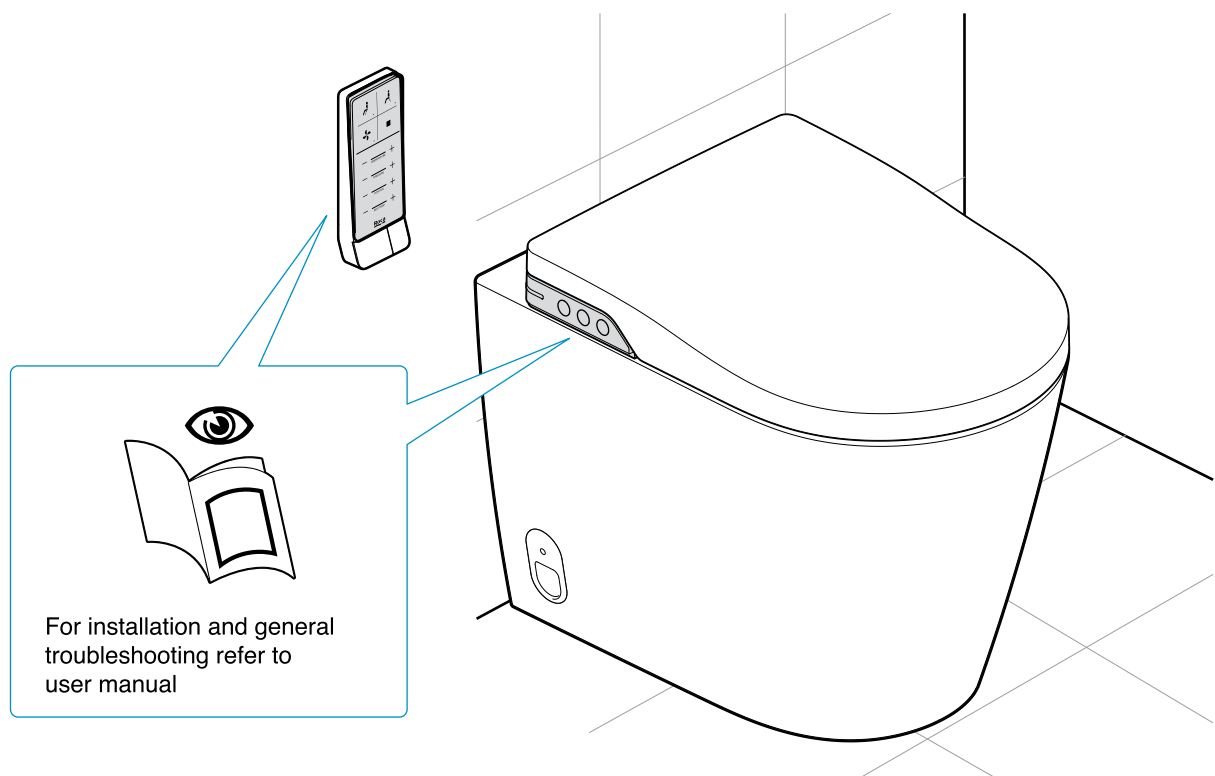

For installation and general troubleshooting refer to user manual



Date 18/07/2024

Roca Sanitario, S.A.
Avda. Diagonal, 513
08029 Barcelona
SPAIN
www.roca.com

933 | LÍNEA DE ATENCIÓN
661 | AL CONSUMIDOR
266 | ESPAÑA 
SERVICIO TÉCNICO 
ESPAÑA



productsupport.rs@roca.net
soporteproducto.rs@roca.net



A807H9510Rd