

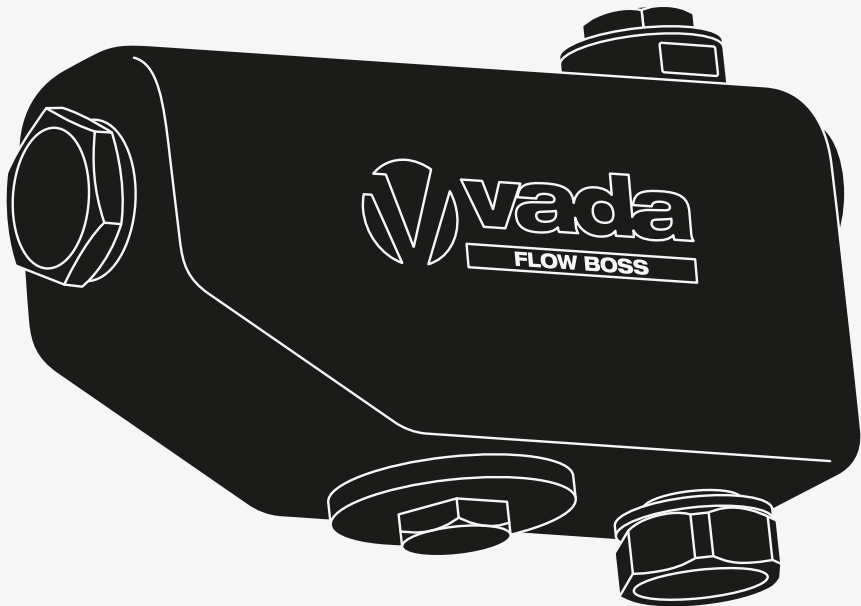

Quick Start Guide

Vada Flow Boss
Mechanical Water Switching Unit 25mm
VFB-MSU25



KNOW YOUR PRODUCT

Meet the Vada Flow Boss Mechanical Water Switching Unit. Designed for seamless water source switching, this unit is built with a solid brass internal and UV stabilised AB plastic casing for reliable operation.

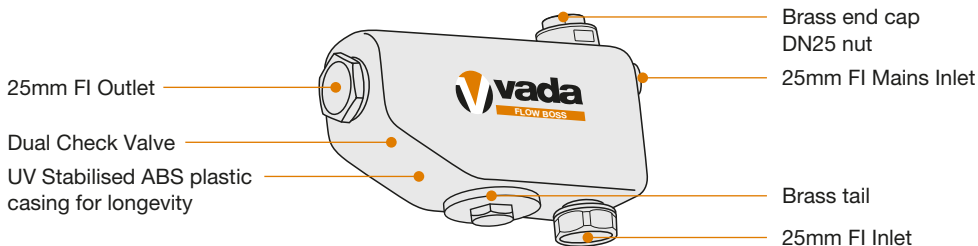

SPECIFICATIONS

- Pump inlet: 25mm FI
- Mains water in: 25mm FI
- Outlet: 25mm FI
- Max mains pressure: 1000kPa
- Min pump pressure: 350kPa
- Max flow rate: 100 litres per minute
- Max water temp: 50°C

HELPFUL HINTS

- Use a suction pipe with a minimum 25mm internal diameter to reduce friction loss.
- Use a pump cover to protect your set up from the elements and increase product lifespan.
- You will need a flathead screwdriver for this installation.
- Ensure your pump set up is equipped with two isolation valves. This allows for fuss free troubleshooting should you need it.
- To optimize pump performance, regularly check and clean the Y-Strainer.

COMPATIBLE VADA PRODUCTS:

- Vada Flow Boss Jet Pump VFB-J90
- Vada Flow Boss Horizontal Multistage Pump VFB-HM80/VFB-HM110
- Vada Flow Boss Submersible Pump VFB-S75
- Vada Flow Boss Auto Pressure Control VFB-APC

ADDITIONAL PRODUCTS REQUIRED FOR INSTALLATION:

- 25mm Y-Strainer (AKA inline strainer)
- Swing check valve
- Pump cover

Note: You may or may not require this additional product, depending on your application.

INSTALLATION



Let's get started!

Before you begin, ensure all relevant instructions have been followed and your pump has been primed.

1. Grab the rubber washer supplied and place it on top of the Auto Pressure Control (VFB-APC) outlet.

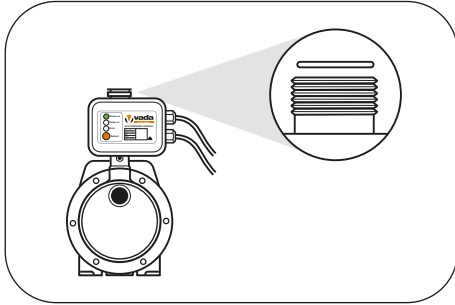

2. Hold the Mechanical Switching Unit (VFB-MSU25) over the outlet and connect the loose nut. Do not overtighten. The rubber washer will lock this in place.

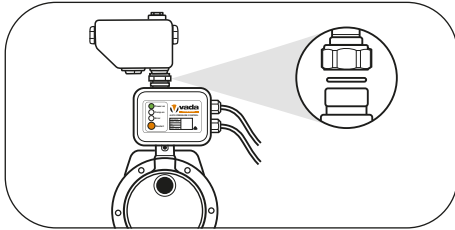

3. Connect the mains water pipe to the VFB-MSU25 outlet labelled "mains in".

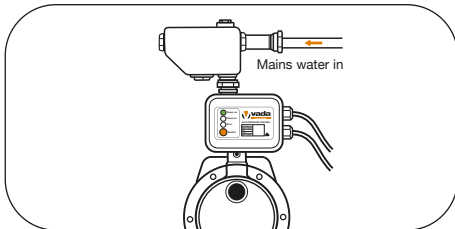

4. Connect the house water pipe to the VFB-MSU25 outlet labelled "to house".

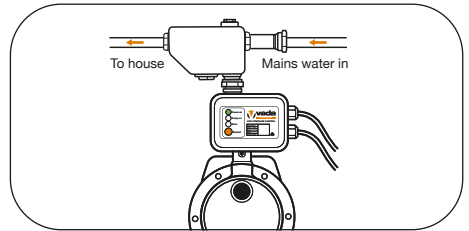

5. For easy maintenance down the track, install an isolation valve into both the mains and house water line.

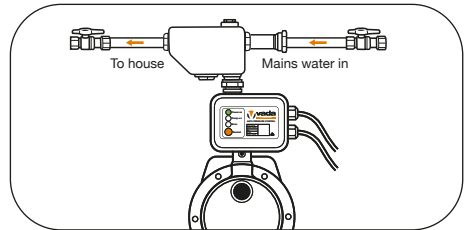

6. Set up the suction line, installing an isolation valve, swing check valve, Y-Strainer and barrel union.

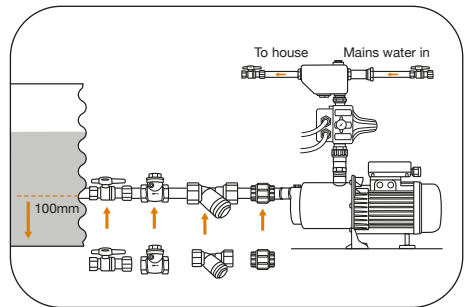

7. Use a pump cover to protect your set up from the elements and increase product lifespan.



ADJUSTING CUT-IN PRESSURE

For a smooth, more reliable changeover between tank and mains water, adjust the cut-in pressure from the default 1.5 Bar to 2.2 Bar. Follow the steps below accordingly.

1. Ensure your pump is primed. Then, turn on the power at the power point.

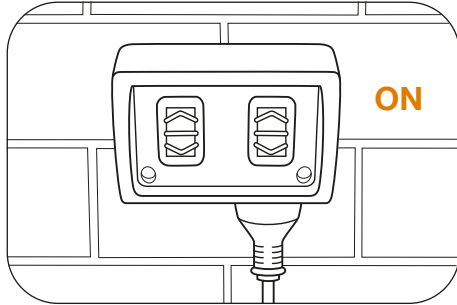

2. Locate the adjustment screw at the back of the VFB-APC.

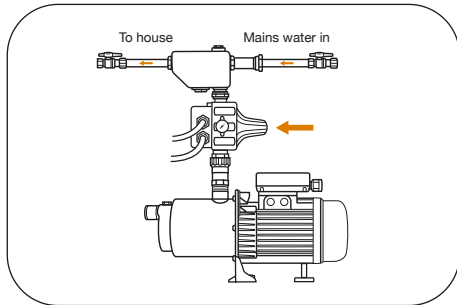

3. Using a flat head screwdriver, turn the adjustment screw clockwise until you reach the correct pressure (approx 3.5 full 360° turns).

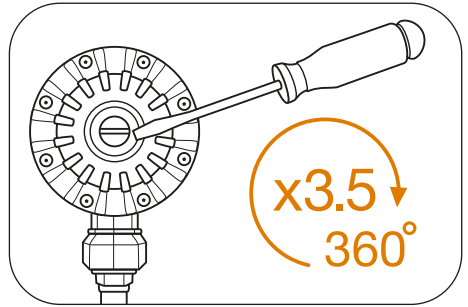

4. Confirm the pressure has been correctly adjusted by slowly opening a tap outlet and checking the gauge on the side of the VFB-APC. If the gauge reads 2.2, the cut-in pressure has been successfully adjusted.

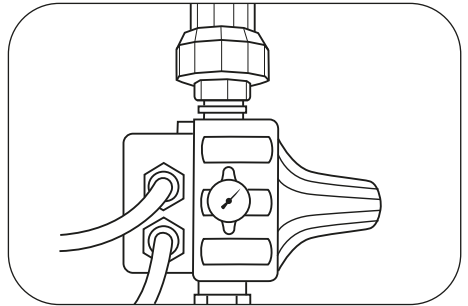

Your pump solution is now ready for operation!