



WOLFEN

USE & CARE MANUAL

DRINKING FOUNTAIN



PRODUCT DIAGRAM

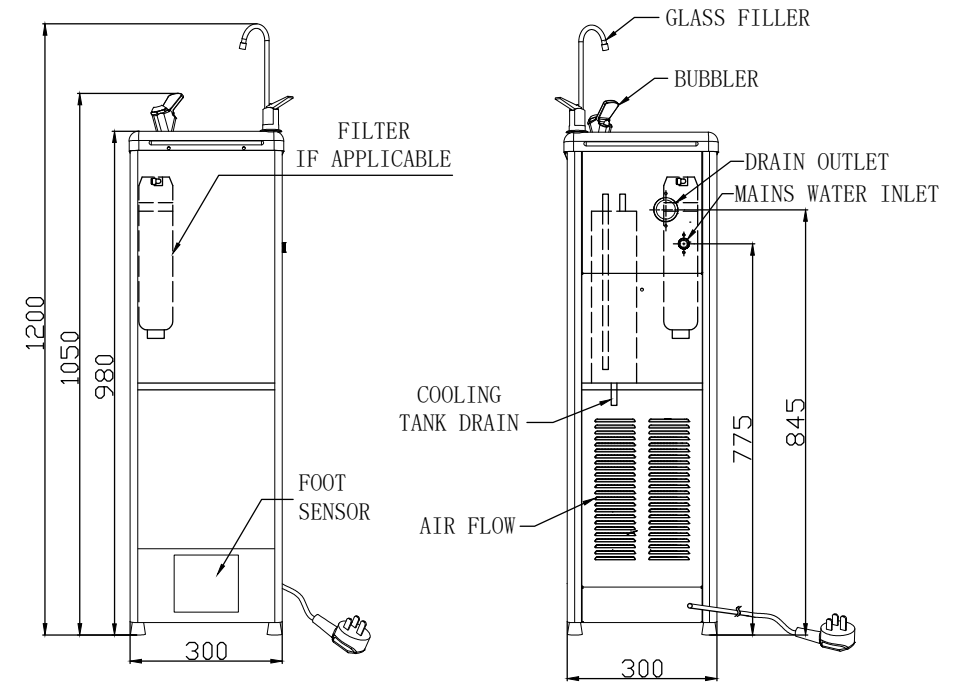

TECHNICAL SPECIFICATIONS

Water Reservoir	5 L	
Refrigeration	Uses R134A refrigerant	
Water Connections	Water Inlet	½" Male B.S.P
	Drain Outlet	40 mm Female P.V.C Socket
Thermostat Control	The thermostat is factory set.	
Capacity	WDF2SS	10 L/h
	WDF5SS	19 L/h
Power Consumption	WDF2SS	145 W
	WDF5SS	237 W
Electrical	220-240 V, 50/60 Hz	
Warranty	Twelve month comprehensive coverage, additional twenty-four month compressor replacement.	

CONTENTS

Product Diagram	03
Safety Instructions	04
Installation	05
Drain Installation	07
Exploded Diagram	08
Warranty	10

IMPORTANT SAFETY INSTRUCTIONS

When using electrical appliances, basic safety precautions should be followed to reduce the risk of fire, electric shock and injury to persons or property. Read all instructions before using any appliance.

1. Keep combustible material such as furniture, bedding, pillows, clothes and/or papers away from the back of the unit.
2. Do not operate this, or any other appliance, with a damaged power cord.
3. No other appliance should be plugged into the same outlet. Be sure that the plug is fully inserted into the outlet.
4. Do not run the power cord over carpeting or other heat insulators.
5. Do not cover the power cord.
6. Keep the power cord away from high traffic areas.
7. Do not submerge the power cord in water.
8. We do not recommend the use of extension cords as they may overheat and increase the risk of fire.
9. Exercise caution and use reasonable supervision when the appliance is used by or near children.
10. Make sure that there is at least 75 mm of space between the back of unit and wall. Keep a minimum of 75 mm on each side of unit free.
11. Do not use this product to dispense anything other than water.
12. This appliance must be placed on an even and flat surface.
13. If the supply cord is damaged, the manufacturer, one of its service agents or a similarly qualified person must replace it in order to avoid hazard.
14. This water fountain must be positioned so the plug is accessible.
15. Disconnect the plug from the outlet when not in use.
16. Remove power plug or disconnect from main power source before servicing the appliance.
17. Warranty will be voided if installation is not carried out as detailed in this instruction manual.
18. The compressor motor is equipped with an automatic reset protector which will disconnect the motor from the line in case of an overload.

UNPACKING THE WATER FOUNTAIN

1. After unpacking the water fountain, wipe with a soft cloth. Check the unit for evidence of rough handling.
2. Place the machine on a hard, flat surface. Make certain the unit is level. The unit should not be close to sources of heat, otherwise performance may be affected.
3. It is best to place the water fountain in an area with good air circulation. Make sure there is at least 75 mm of space between the back of the fountain and the wall.

INSTALLATION

The installation must be in accordance with AS/NZS 3500.1 and AS/NZS 3500.2. Pipe jointing is a trade skill and Reece recommends this process is performed by qualified personnel only.

FILTER INSTALL INSTRUCTIONS

Please refer to the instructions below if your unit is supplied with a filter kit.

Refer to below for information on disconnecting tube.

1. Your new Wolfen drinking fountain comes with enough 1/4" line and a fitting that can be disconnected to allow for easy filter installation. Open the front panel of the fountain and identify the 1/4" to 1/4" straight connector located on the water inlet line between the inlet fitting and the tank. Discount the 1/4" from both sides of this straight connector. Keep the connector fitting in case you need it for future troubleshooting purposes.
2. Connect the stem elbows into the filter bracket. Connect the water lines from the pressure limiter valve and the tank. Ensure you follow the flow arrow on the bracket.
3. Fasten the filter head onto the included bracket using the fittings provided.
4. Ensure the filter bracket unit is secured onto the chassis frame using the fittings provided within the drinking water fountain's instruction manual plastic pouch.
5. Lock the filter into place. Approximately a quarter turn will lock it into place.
6. When using for the first time, check for leaks and run water through the machine continuously (through the bubbler or glass filler) for five minutes to flush the filter and ensure the tank is free of any air pockets.

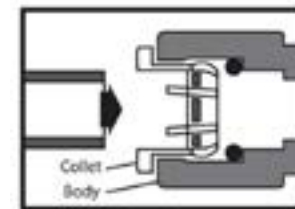

To connect, push tube through collet ring into body.

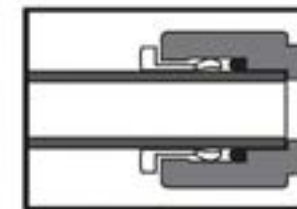

Tube must sit fully past o-ring.

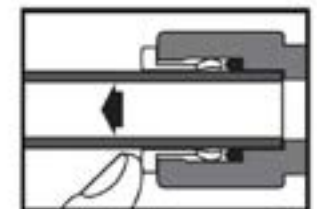

To disconnect, hold collet ring against body pull tube out.

IMPORTANT INFORMATION ABOUT GROUNDING

To provide additional protection from the risk of shock, this unit **MUST** be connected to a residual-current device (RCD) outlet at all times. Use of an extension cord will void any warranties.

This appliance must be grounded. Improper use of the grounding plug can result in a risk of electric shock, causing serious injury and possibly death.

This appliance is equipped with a power cord having a grounding wire with a grounding plug and must be connected into a properly-grounded, polarised outlet.

Consult a qualified electrician if the grounding instructions are not completely understood, or if doubt exists as to whether the appliance is properly grounded. If the wall outlet is a standard, 2-prong outlet, it is your personal responsibility and obligation to have it replaced with a properly-grounded, 3-prong wall outlet.

Do not under any circumstances cut or remove the third (ground) prong from the power cord plug. Do not use an adapter plug with this appliance.

WATER CONNECTION INSTALLATION

1. Ensure proper ventilation by allowing 75 mm clearance on each side of the fountain.
2. Minimum water pressure is 100 kPa and maximum is 700 kPa.
3. The recommended maximum water inlet temperature is 38°C.
4. Install a 40 mm waste trap onto the waste outlet on the rear of the fountain - not supplied.
5. Water in connection is secured via a ½" kinko nut and olive into the stainless-steel connection on the rear of the unit. It is recommended that a ½" shut off valve is installed at this point for ease of future maintenance.
6. Turn on water supply and hold down bubbler to purge the system of air until a steady stream of water comes from the tap.
7. For models equipped with a glass filler, please remove the white tubing from the hole and then assemble the glass filler by placing the neck into the hole on the top of the lid, as shown below. Swivel glass filler to be over top of unit.
8. The bubbler needs to be adjusted for the correct water flow in relation to the local water pressure. On the side of the bubbler is an inner and an outer screw. Once you have established water flow, adjust the inner screw until the stream is in the centre of the stainless-steel top.
9. Check all connections for water leaks.
10. Flush fresh mains water through the unit for five minutes to ensure any residual water from testing is cleared.
11. Plug the fountain into the building electrical supply. The unit will start automatically.



Glass filler installation



Flow adjustment



DRAIN INSTALLATION

NOTE: Pipe jointing is a trade skill and should be executed only by qualified persons. Reece recommends installing a union as part of the PVC drain assembly to enable ease of disconnection if the fountain requires service.

1. Make sure all connections are cleaned and dry.*
2. Mark waste pipe at a distance equivalent to full depth once inserted into the drain fitting on the unit.
3. Apply Watermark certificated Type N solvent cement on the end of the Watermarked AS/NZS 1260 40mm PVC pipe and insert into the drain outlet fitting. Firstly to the inside of the drinking fountain drain fitting and then to the external surface of the pipe end (marked area). (See Figure.1) **
4. Please ensure the solvent cement is applied in full even coats to all applicable surfaces.
5. Follow the direction line in figure.1 to connect the PVC pipe to the full depth of the socket and hold the bond joint in position for at least 30 seconds.
6. Do not disturb for 5 minutes and allow 24 hours curing before testing. (See Figure.2)

* Reece suggests using PVC priming fluid to prime PVC pipe prior to application of PCB pipe cement for all installations.

** Using both pipe cement type N and type P are both acceptable. Pipe cement type P is recommended in high pressure application for bonding, while type N is for the non-pressure application. Reece recommends using pipe cement type N complying with AS/NZS3879 for this application.

Please be aware that the connection should be done by an Australian certified plumber.

The socket is adaptable to Watermarked AS/NZS 1260 40mm PVC pipe fitting as per the WMTS105 documentation.

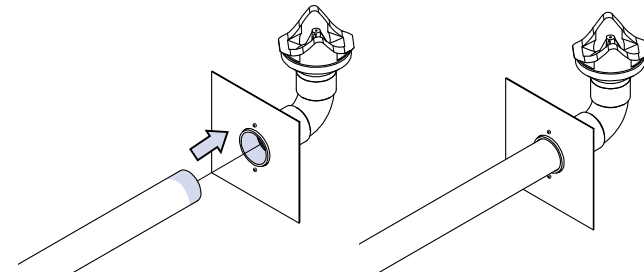

REMOVING FROM SERVICE

1. Disconnect the power supply cord.
2. Disconnect the water supply.
3. Remove drain assembly from rear of the fountain.
4. Remove bubbler valve and if present, remove glass filler spout from base by firmly pulling upwards away from the drinking fountain.
5. Always drain all water when freezing temperatures are anticipated and before shipping the fountain.

MAINTENANCE

- The only maintenance operation required is the removal of dirt and lint from the condenser. Inspection should be made at monthly intervals.
 - Disconnect the power supply.
 - Clean the condenser with a small stiff non-wire brush.
- The unit is equipped with a hermetically sealed compressor and requires no additional lubrication.
- The fan motor on this unit seldom needs oiling. If required, a few drops of SAE 10 oil should be used.

TROUBLESHOOTING

Problem	Possible Cause	Remedy
No water flowing out of the glass filler or bubbler	Water source has been suspended	Restore water supply.
	The filtration system is clogged	Replace the filter.
Water is not cold	The cooling controller is turned off	Check the position of the mechanical thermostat and set to desired temperature.
	Power failure	Check the power cord is properly plugged in or if there is a power outage.
	Cooling system failure	Turn off the fountain and contact Reece service.
Water is continually flowing internally from tank through to drain	Internal Pressure Release Valve (PRV) is not set correctly to suit customers premise	Use flat blade screw driver to adjust pressure release valve very gently clockwise until water stops dripping. This is an overpressure safety system to prevent the tank bursting. Ensure that adjustments are made to the PRV carefully. Be sure that the cause of the dripping is not that actually the tank is frozen solid caused by faulty thermostat or very low ambient temperature conditions.
Low flow through bubbler outlet	Bubbler valve screw not adjusted according to water pressure	Adjust small screw on side of bubbler gently while activating the bubbler valve using the foot sensor so flow is increased/ decreased based on your needs.
	Units Pressure Limiting Valve (PLV) is faulty	Bypass the units grey cylinder shaped pressure limiting valve on the internal pipe work between rear inlet connection and tank. If the flow is correct after bypass, please contact Reece for support.
	Bubbler solenoid or foot sensor faulty	If unit is fitted with a separate glass filler, check to see if flow is affected in glass filler as well as bubbler. If the flow is only affected with the bubbler, and the glass filler is working fine, please contact Reece for support.
Low flow through glass filter unit	Units Pressure Limiting Valve (PLV) is faulty	Bypass the units grey cylinder shaped pressure limiting valve on the internal pipework between rear inlet connection and tank. If the flow is ok after bypass, please contact Reece for support.

SPARE PART LIST

#	Description	Code
1	Glass filler (optional)	SPM1
2	Bubbler valve	SPM2
3	Stainless-steel lid	SPM3
4	Waste drain gasket	SPM4
5	Bubbler connection	SPM5
6	Waste drain elbow	SPM6
7	Frame assembly	SPM7
8	Cold tank assembly	SPM8
9	Evaporator	SPM9
10	Cold thermostat	SPM10
11	Condenser	SPM11
12	Power cord	SPM12

#	Description	Code
13	Rubber feet	SPM13
14	Compressor	SPM14
15	Condenser bracket	SPM15
16	Fan blade	SPM16
17	Fan cover	SPM17
18	Fan motor	SPM18
19	Pressure relief valve	SPM19
20	PLV(DV Pressure limiting valve)	SPM20
21	Solenoid valve	SPM21
22	Sensor (trigger)	SPM22
23	Rear panel	SPM23
24	Front panel	SPM24

ELECTRICAL DIAGRAM

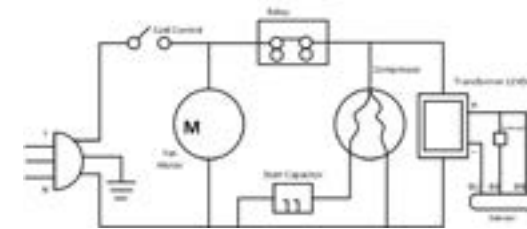

MARKS



The appliance is comply with applicable ACMA regulatory arrangements (Regulatory Compliance Mark) and WaterMark WMTS 105:2016.

REECE PRODUCT QUALITY GUARANTEE



You have purchased a quality product from Reece Australia Pty Ltd ABN 84 004 097 090 ("Reece"). This product is covered by a 5 year replacement product warranty and a 12 month warranty over spare parts and labour.

5 YEAR WARRANTY

This warranty covers faults in the product construction, material and assembly. Products which are within 5 years from the date of purchase, found upon inspection by an authorised Reece representative, to be defective in construction, material or assembly, will be repaired or exchanged with an equivalent product free of charge. Replaced items become Reece's property.

All replacement products will be available for collection without charge to the customer at the nearest Reece branch to the customer's location, or elsewhere as agreed between the customer and Reece.

Labour and Spare Parts

The labour for the replacement of products and spare parts to which this warranty applies will be supplied by Reece or relevant supplier using licensed plumbers engaged by Reece or relevant supplier within 1 year from the date of purchase. Spare parts other than those listed in the Manufacturer's Provisions above, which are within 1 year from the date of purchase found upon inspection by an authorised Reece representative to be defective in construction, material or assembly, will be replaced free of charge.

Warranty Conditions

This warranty will apply only under all of the following conditions:

- The item has been installed by a licensed plumber
- Failure is due to a fault in the manufacture of the product
- Proof of purchase (including the date of purchase) is provided
- The installation of the product is in accordance with the instructions provided

This warranty does not cover products purchased as an ex-display without being fully checked and tested for sale by the manufacturer.

This warranty does not include faults caused by:

- Unsuitable or improper use
- Incorrect installation or installation not in accordance with the instructions provided
- Installation or part installation by the purchaser or any person other than a LICENSED PLUMBER
- Normal wear and tear
- Inadequate or complete lack of maintenance
- Chemical, electrochemical or electrical influences
- Harsh detergents or abrasive cleaners used on product finishes

EXCLUSIONS

To the fullest extent permitted by law, Reece excludes all liability for damage or injury to any person, damage to any property, and any indirect consequential or other loss or damage.

CLAIM PROCEDURE

For all warranty queries customers are to contact the branch where the product was purchased. These details can be found on your purchase invoice.

Our goods come with guarantees that cannot be excluded under the Australian Consumer Law. You are entitled to a replacement or refund for a major failure and for compensation for any other reasonably foreseeable loss or damage. You are also entitled to have the goods repaired or replaced if the goods fail to be of acceptable quality and the failure does not amount to a major failure.

Don't risk it, use a licensed plumber.™

IF AFTER CHECKING THE INSTALLATION INSTRUCTIONS AND IMPORTANT INFORMATION, THE PROBLEM HAS NOT BEEN IDENTIFIED, CUSTOMERS ARE TO CONTACT THE BRANCH WHERE THE PRODUCT WAS PURCHASED. THESE DETAILS CAN BE FOUND ON YOUR PURCHASE INVOICE.

General contact details for Reece are as follows:

Reece Australia Pty Ltd

118 Burwood Hwy

Burwood VIC 3125

+61 3 9274 0000

admin@reece.com.au



WOLFEN™

reece.com.au/wolfen