

BIS RapidRail® T- and X-Connector

(G 35 45)

to make BIS RapidRail® fabrications

A



B

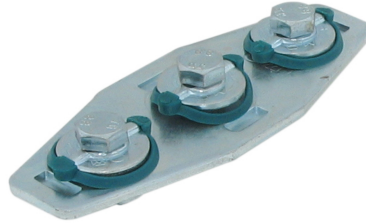

Features and Benefits

- connector with pre-assembled BIS RapidRail® Slide nut(s)
- to make rail fabrications
- suitable for rail WM0, 1, 15, 2, 30, 35
- ready-to-use pre-assembled for a quick fixing, and retains assembly in place before final tightening
- material: metal parts made of steel 1.0332; spring(s) made of POM (polyoxymethylene), green
- zinc plated

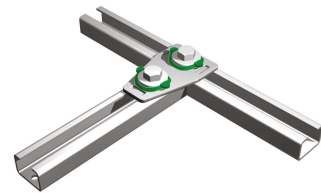

658 4 090

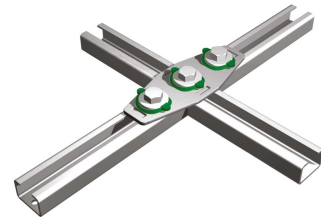

658 4 091

Part No.	Type	T _(max.) (Nm)	For Rail	F _{a,x} (N)	RAL	Pack 1
A 6584090	T	15.0	WM0 - 35	345	RAL ¹	25
B 6584091	X	15.0	WM0 - 35	345	RAL ¹	25

*RAL¹ = tested, certified and monitored by a third party according to RAL-GZ 655/D in combination with Rail WM1, 2, 15 and 30.
For detailed technical information about our RAL marked products, please see the RAL datasheet in our web catalogue.*



RAL-GZ 655/D
Cert.Nr. 2012-08

A

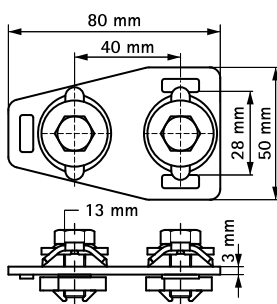

B

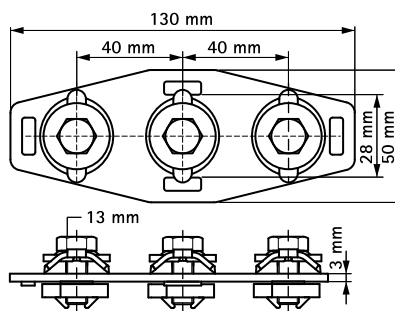

Complementary
RapidRail® Fixing Rail