

AXA

OM UNDERCOUNTER BASIN

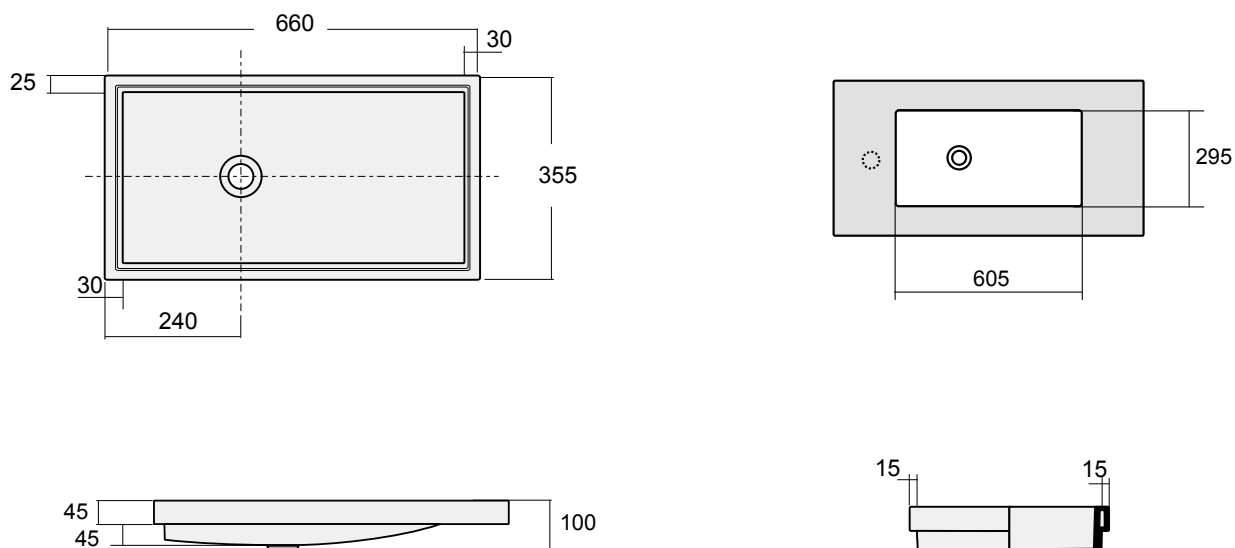

Dimensions are nominal measurements only.

SPECIFICATIONS

Recommended use	Domestic, Hotel and Commercial
Material	Ceramic
Colour	White
Capacity	10 Litres
Weight	9kg
Fixing	Undermount installation
Taphole availability	No
Overflow	No
Plug and waste	40mm waste (Not supplied)
Cut out template	Supplied



To see the complete AXA range go to www.reece.com.au/bathrooms

CLEANING RECOMMENDATIONS

We recommend the use of soapy water or approved cleaners.

This product should not be cleaned with abrasive materials.

Damage caused by any improper treatment is not covered by the product warranty - Refer to Warranty Conditions.

Disclaimer: Products in this specification manual must by regulation be installed by licensed and registered trade people. The manufacturer/distributor reserves the right to vary specifications or delete models from their range without prior notification. Dimensions are nominal measurements only. Dimensions and set-outs listed are correct at time of publication however the manufacturer/distributor takes no responsibility for printing errors.

Tech Page Version 2

AXA OM UNDERCOUNTER BASIN

INSTALLATION INSTRUCTIONS

1. Cut out benchtop as per template supplied.

NB: - Please consider installed position of basin, to ensure minimal water splash from tapware selected.

2. Attach timber batons of height 4cm to the underside of benchtop. (diagram a).

3. Apply silicone to rim of basin in groove. (Do not use epoxy glues). (diagram b)

4. Position washbasin and secure by screwing down metal fixing plates into timber batons. (diagram c)

5. Remove any excess sealant.

