

Laufen Ino Counter Basin with Overflow No Taphole 500mm White

| SPECIFICATIONS | |
|------------------------|---|
| Recommended Use | Domestic, Hotel & Commercial |
| Material | Saphirkeramic |
| Colour | White |
| Bowl Capacity | 5.9 Litres |
| Weight | 7.0kg |
| Fixing | Installation Dimensions & Fixing Set (included) Waterproof Flexible Sealant (not included) |
| Taphole Configuration | No Taphole |
| Overflow Configuration | Overflow |
| Waste Size | Suits 32x40mm Overflow Waste |
| Plug & Waste | Sold Separately |
| Tapware | Sold Separately |

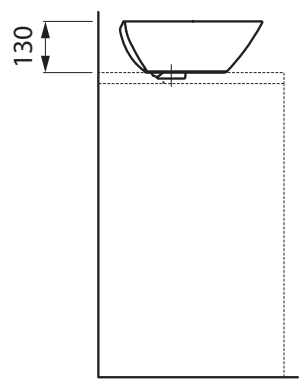

| WARRANTY | |
|--|-----------|
| Warranty - Domestic Use | 15 Years |
| Spare Parts & Labour | 12 Months |
| <i>Please refer to Warranty Page for full Terms and Conditions</i> | |

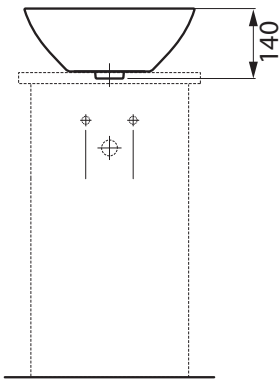
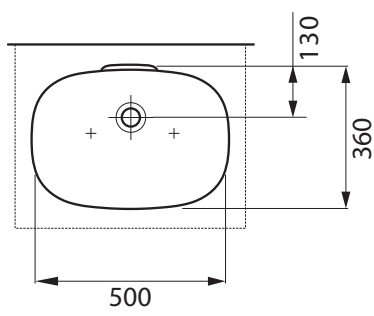

Dimensions are nominal measurements only.

Disclaimer: Products in this specification manual must by regulation be installed by licensed and registered trade people. The manufacturer/distributor reserves the right to vary specifications or delete models from their range without prior notification. Dimensions are nominal measurements only. Dimensions and set-outs listed are correct at time of publication however the manufacturer/distributor takes no responsibility for printing errors.

Published 16/01/2018

To see the complete Laufen range go to www.reece.com.au/bathrooms

