

LAUFEN

ILBAGNOALESSI One

FREESTANDING BATH

INSTALLATION

GENERAL INSTALLATION INSTRUCTIONS

These instructions for use must be carefully read before installation.

Check on content of delivery and condition of the components

Check delivery after receipt for completeness and possibly damage (see parts list on page 8). Inform the dealer immediately when damage is apparent. We are not liable for damage arising during or after installation/ fitting.

Check door width before starting work:

Does the bath pass through the door of the room in which the bath will be installed? Required minimum door width: See dimensions on page 5.

Laying circuits:

Do not lay any circuits under the bath.

Protection from damage:

Use suitable protective covers to prevent damage to surfaces and blockages by dirt or dust arising during fitting. Provide tub with additional protective cover, before beginning installation.

Special precautions:

When cleaning the tiles, make sure that no ammoniac or a similar aggressive cleaning agent come into contact with the installed parts.

Water connection:

As soon as the water inlet is below the rim of the tub, the connection must be made with a safety device according to EN 1717 (Fluid category 5). For example, that might be a DC safety de-vice (e.g. a type A 1 pipe-interrupter with permanent connection to the atmosphere) depending on the installation requirements. This connection must absolutely be effected by a qualified specialist. This is to be observed with all tubs that are filled through the overflow. The connection must be made using reinforced elastic tubing carrying the premixed hot and cold water.

Feed rate: Maximum 20 litres/min (EN 200)

Overflow rate: Minimum 36 litres/min (EN 274)

Drainage rate: Minimum 48 litres/min (EN 274)

Permanent installation:

Recommendation: Also provide 20 x 20 cm maintenance hatches for drainage/ overflow. Install with sound insulation. Removable side panels are ideal and rigid elements are always to be preferred. Maintenance hatch can also be put in the adjacent room.

If space is tight:

If there is not enough space for the maintenance hatch, we recommend installing the tub by „applying” it to the surfaces so that, if necessary, the complete tub can be removed. Ensure that the drainage pipe and if necessary the water supply lines can be uncoupled through the ventilation opening. Seal all round the edge of tub with silicone (acetic acid-free).

Checking that the tub is waterproof:

After connecting the water supply and drainage pipes, the tub must be filled and examined to ensure that it is waterproof.

Plumbers, please ensure a copy of the installation instructions is left with the end user for future reference

LAUFEN ILBAGNOALESSI One FREESTANDING BATH

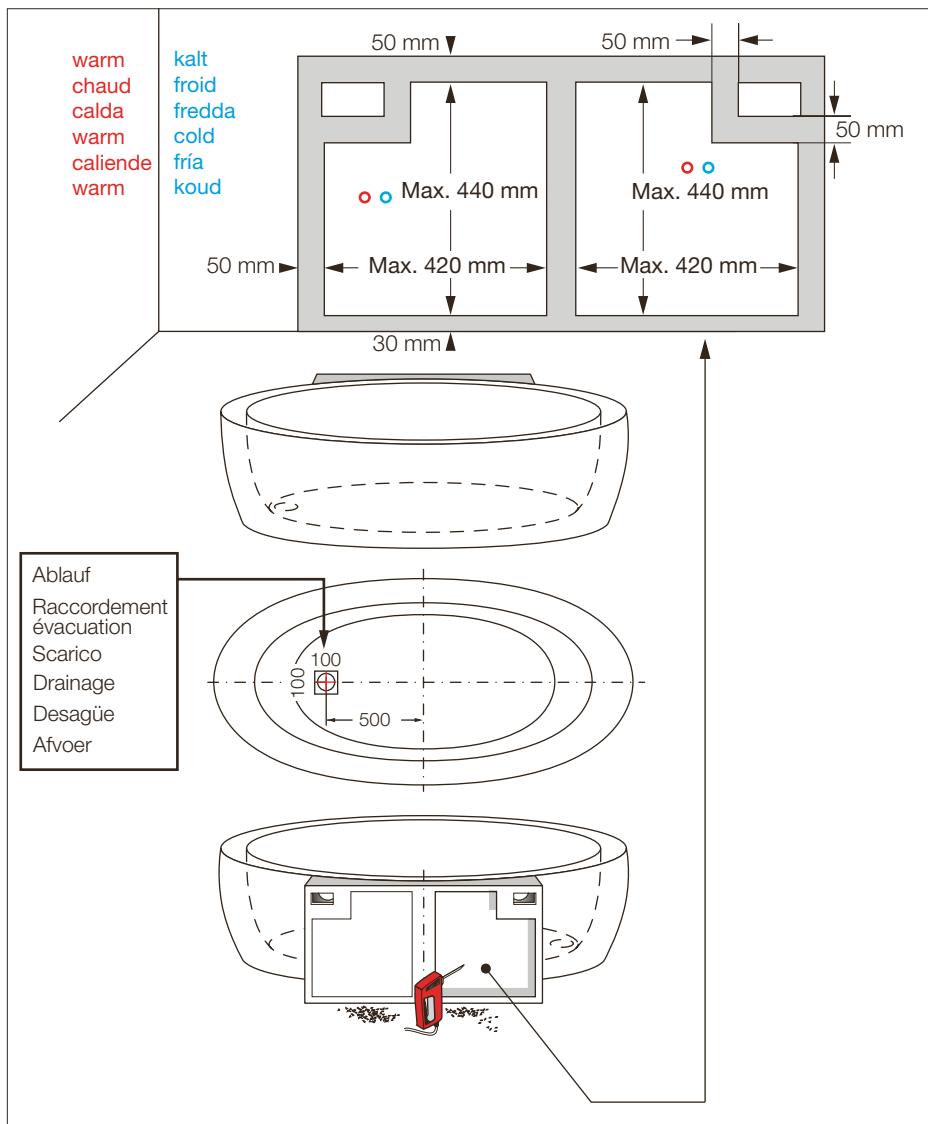
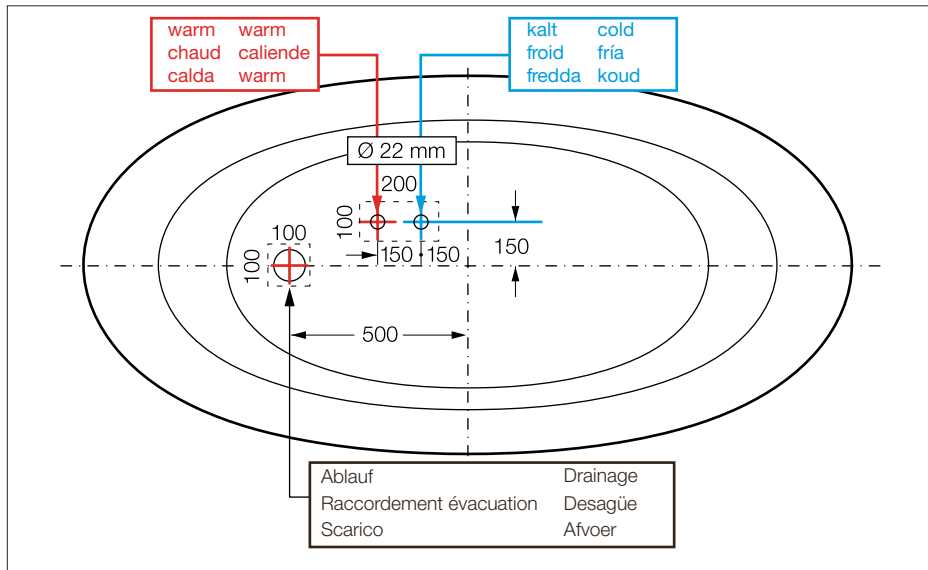

LAUFEN

ILBAGNOALESSI One

FREESTANDING BATH

Masse mm
 Dimensions mm
 Dimensioni mm
 Dimensions mm
 Dimensiones mm
 Afmetingen mm

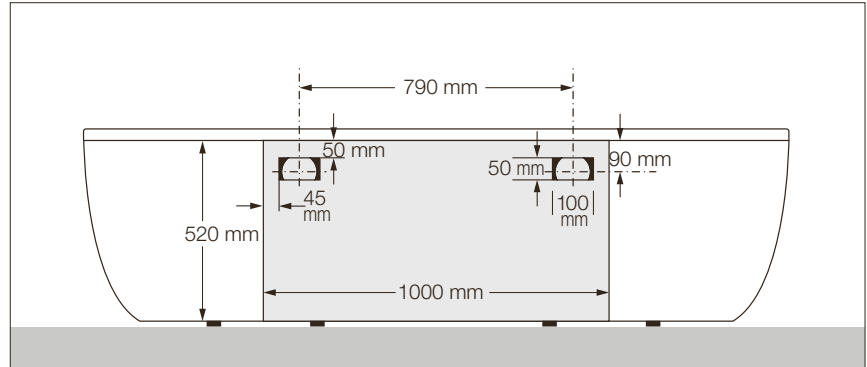

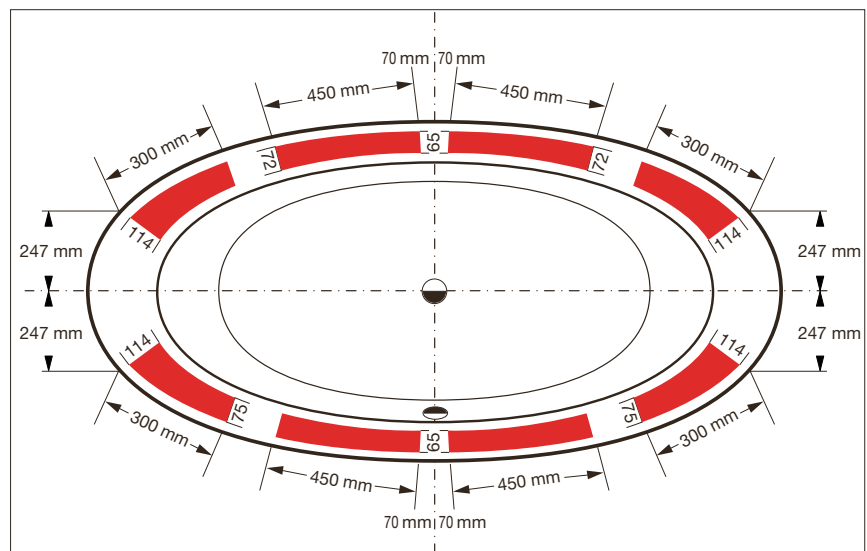

Empfohlene Armaturenordnung
 Dispositions possibles de la baignoire
 Disposizione consigliata della rubinetteria
 Recommended armature layout
 Disposición recomendada de la grifería
 Aanbevolen positie kranen

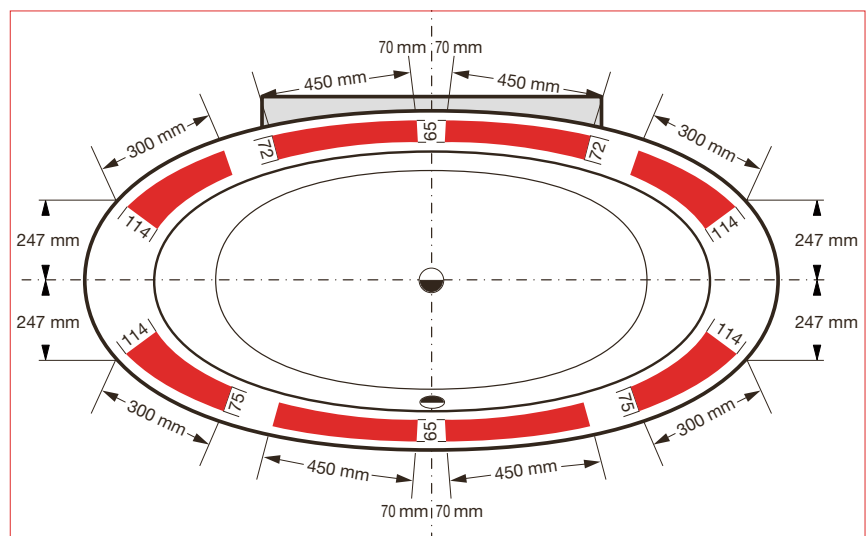

Empfohlene Armaturenordnung
 Dispositions possibles de la baignoire
 Disposizione consigliata della rubinetteria
 Recommended armature layout
 Disposición recomendada de la grifería
 Aanbevolen positie kranen

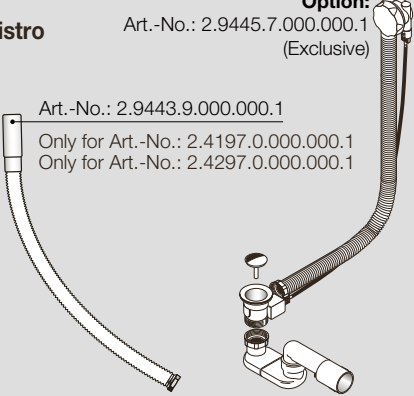

LAUFEN ILBAGNOALESSI One FREESTANDING BATH

Lieferumfang Contenu du colis Distinta dei pezzi	Parts list Alcance del suministro Toebehoren	Option: Art.-No.: 2.9445.7.000.000.1 (Exclusive)
		
Only for Art.-No.: 2.4297.0.000.000.1 Art.-No.: 2.9460.3.000.000.1 		
 Art.-No.: 2.9458.6.000.000.1		Art.-No.: 2.9443.9.000.000.1 Only for Art.-No.: 2.4197.0.000.000.1 Only for Art.-No.: 2.4297.0.000.000.1

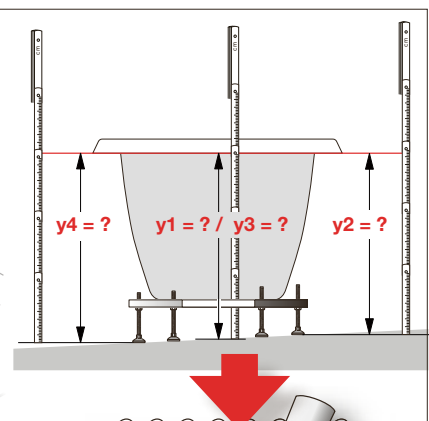
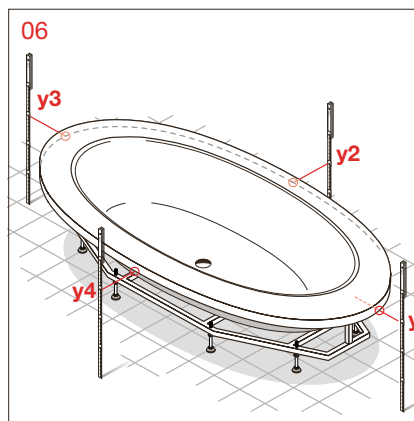
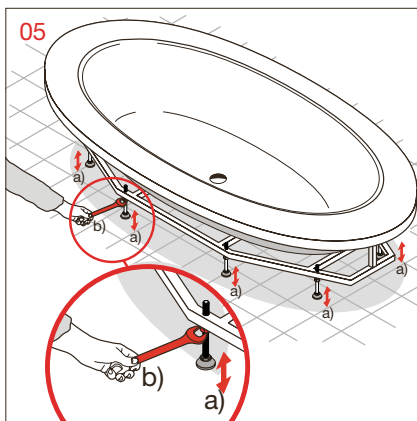
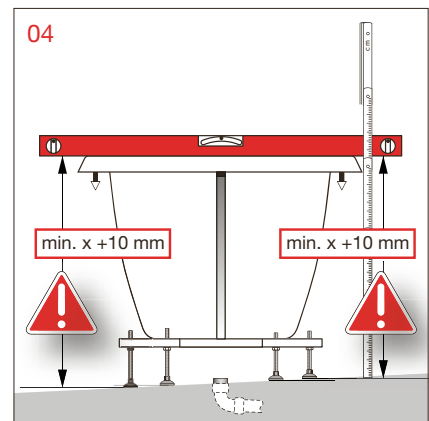
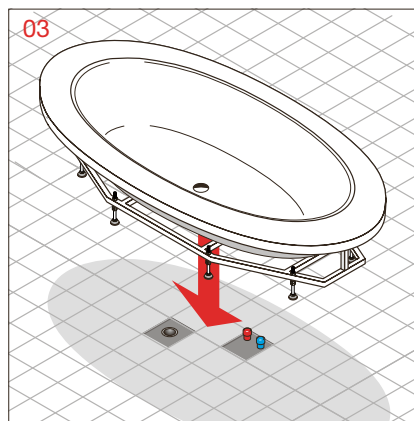
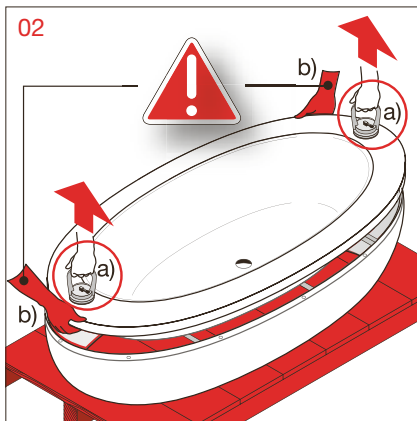
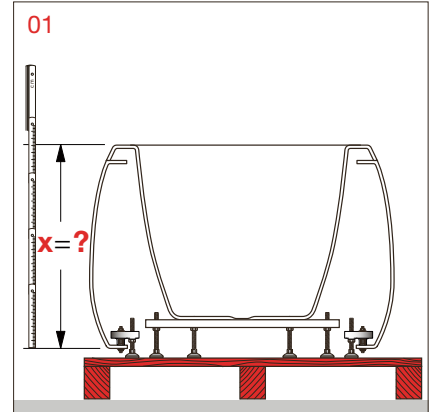
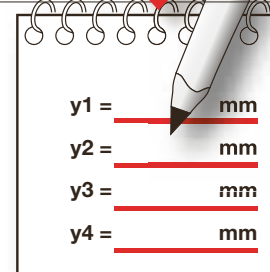



y1 = _____ mm
 y2 = _____ mm
 y3 = _____ mm
 y4 = _____ mm

LAUFEN

ILBAGNOALESSI One

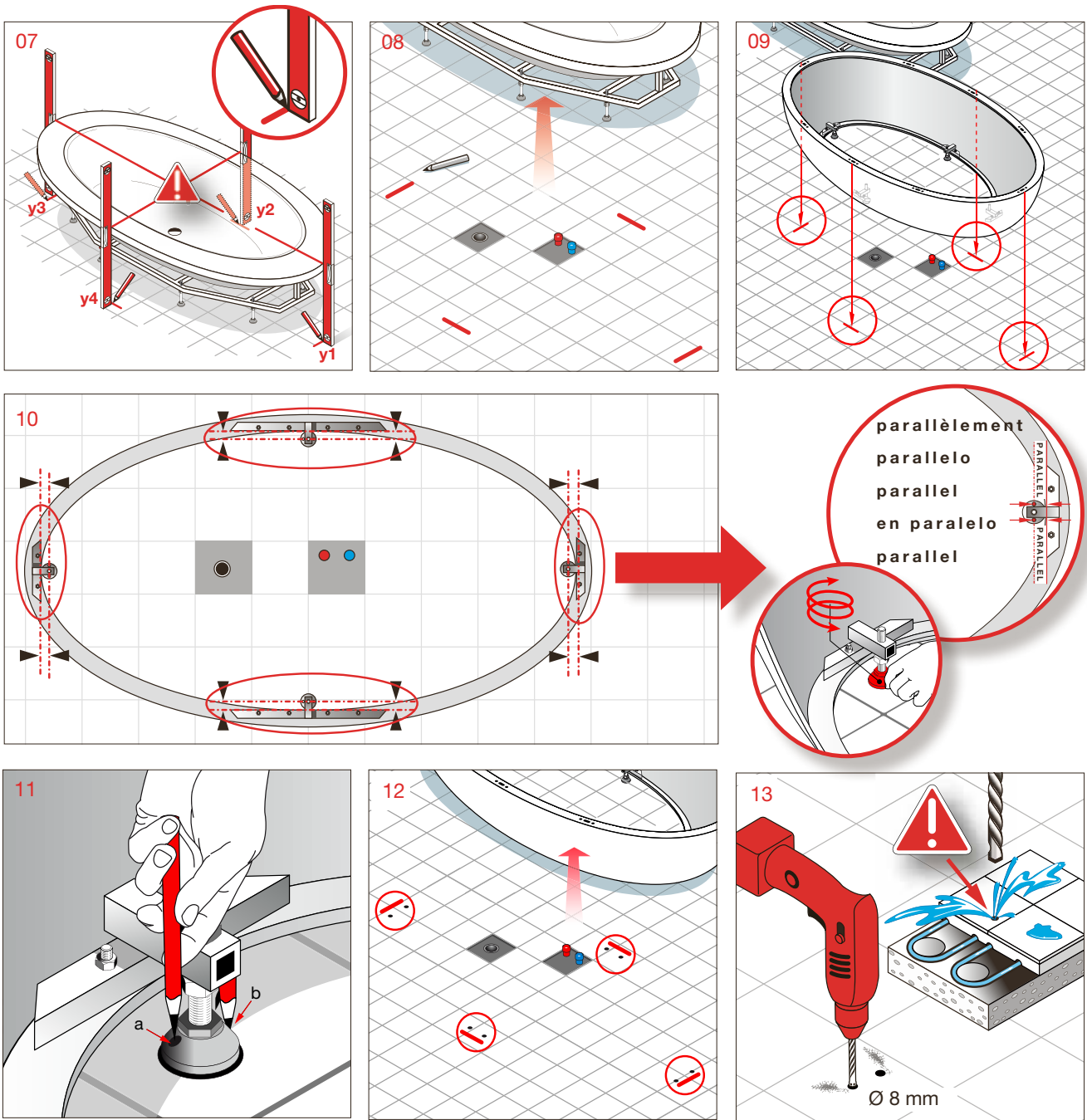
FREESTANDING BATH



LAUFEN

ILBAGNOALESSI One

FREESTANDING BATH

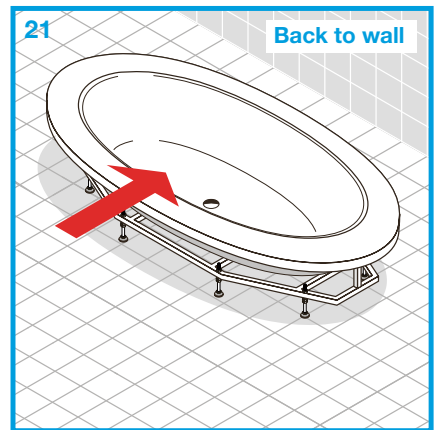
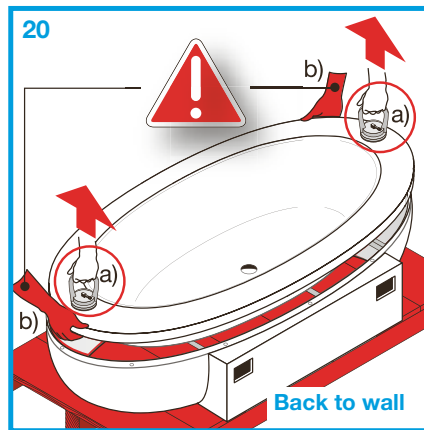
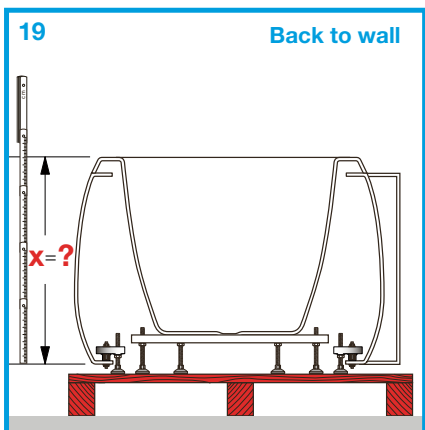
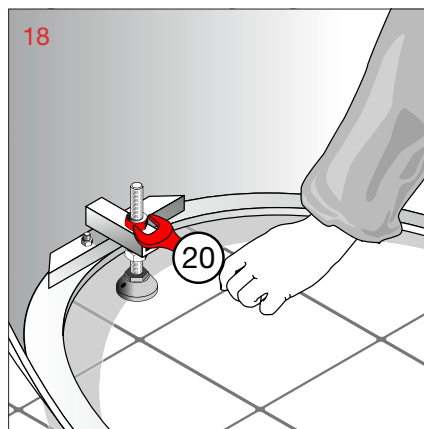
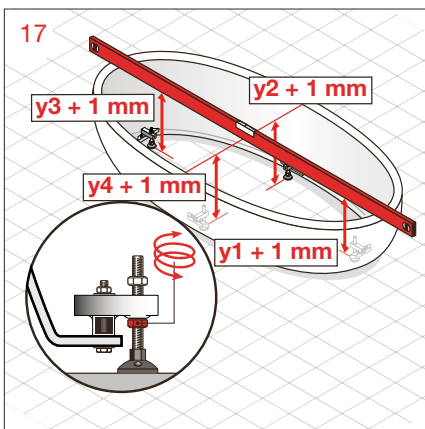
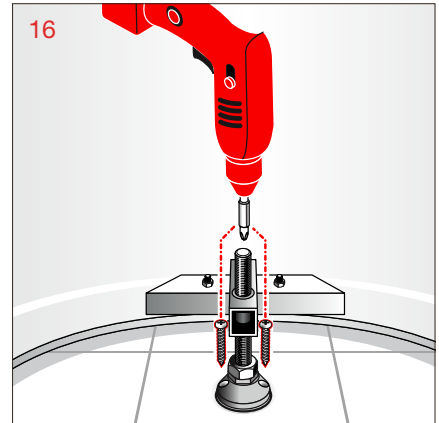
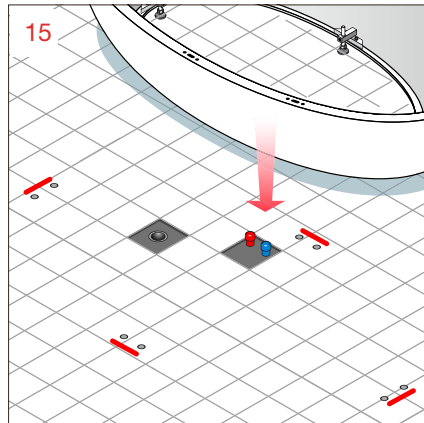
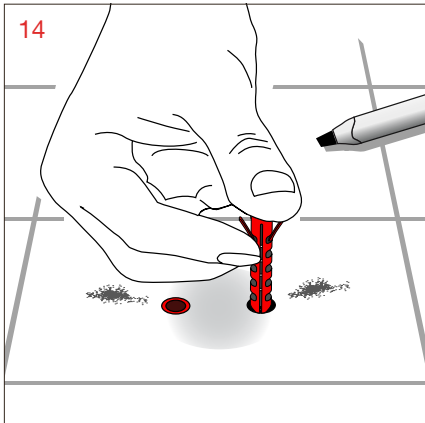

LAUFEN ILBAGNOALESSI One FREESTANDING BATH

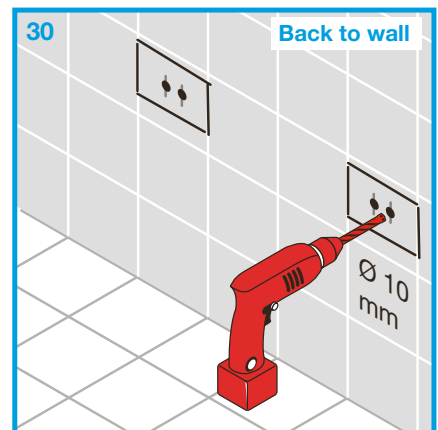
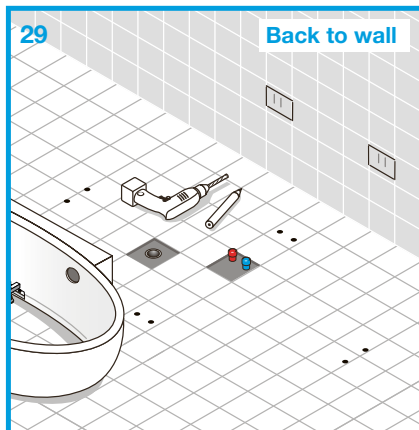
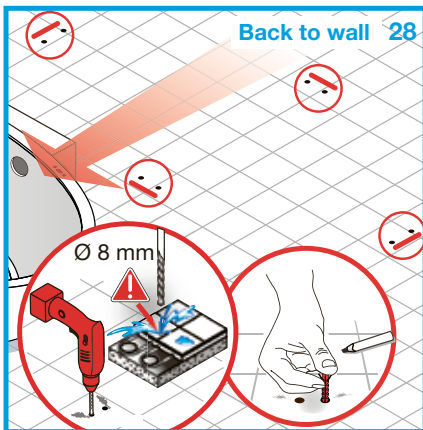
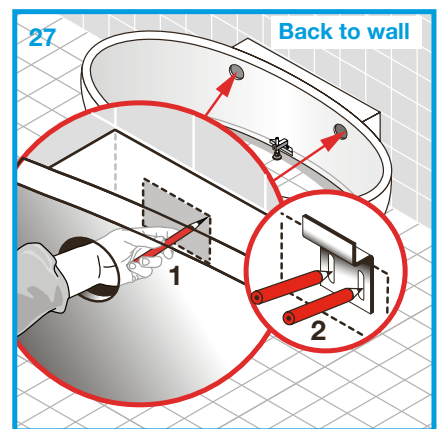
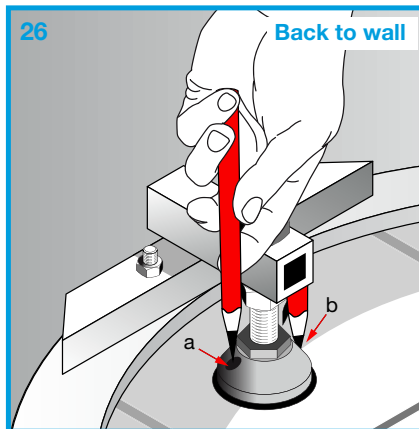
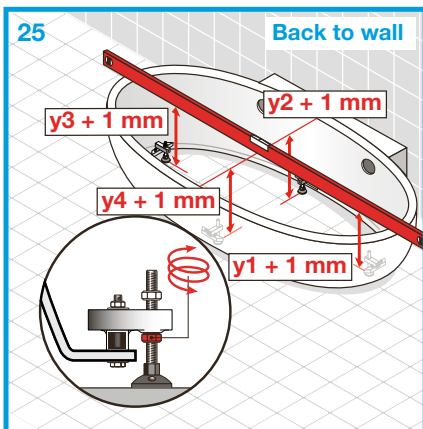
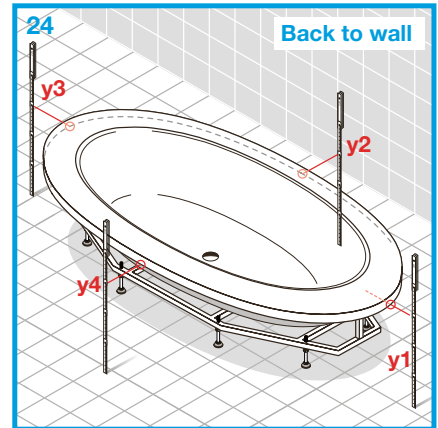
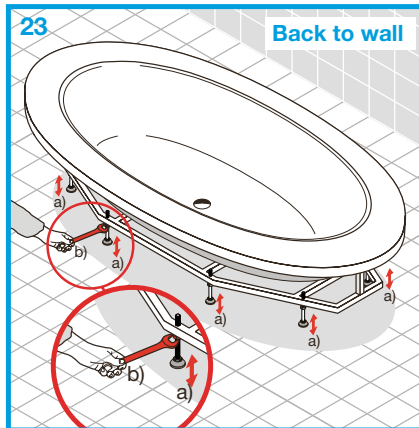
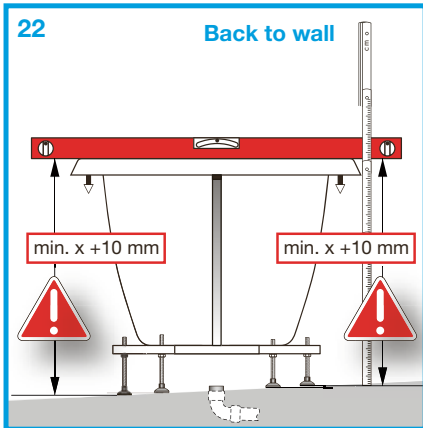

LAUFEN ILBAGNOLESSI One FREESTANDING BATH

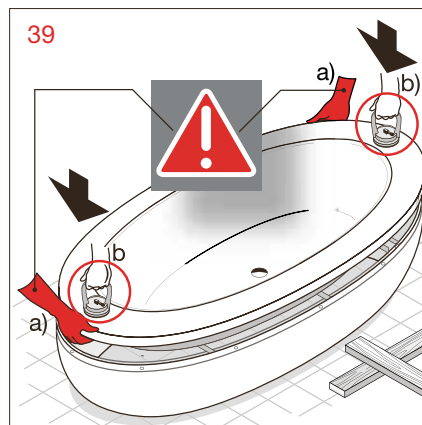
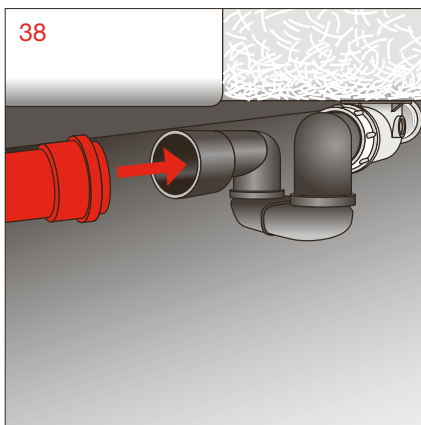
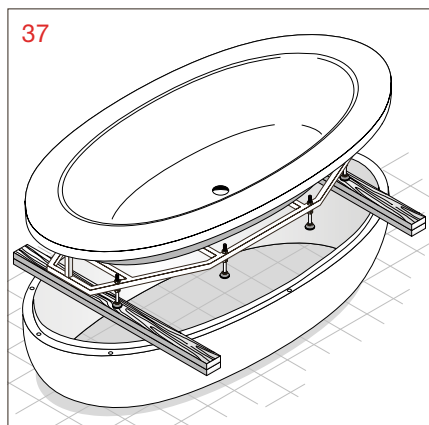
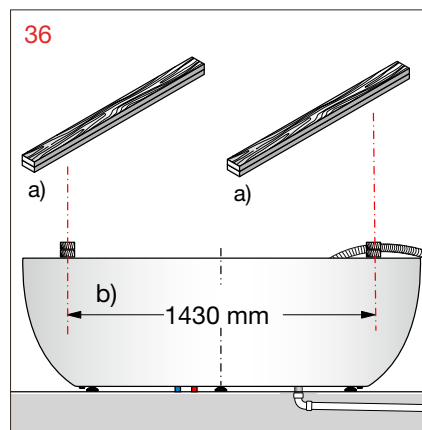
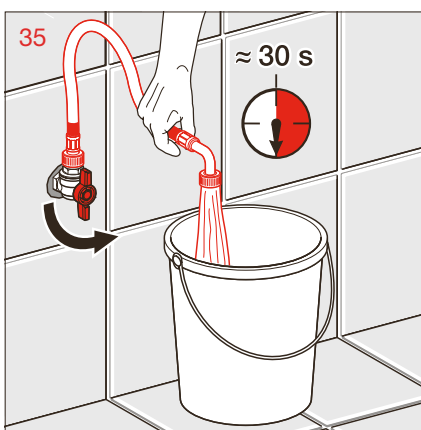
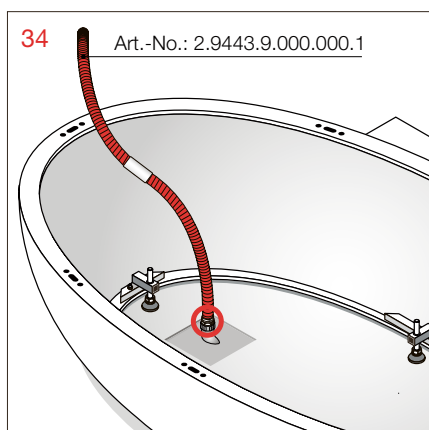
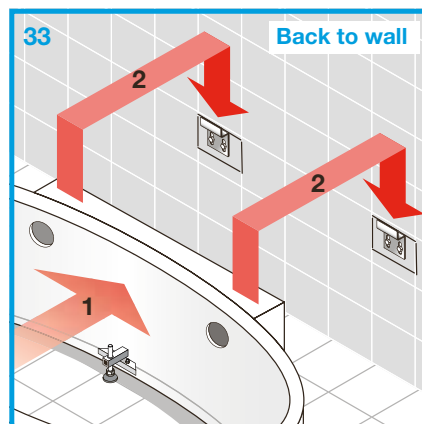
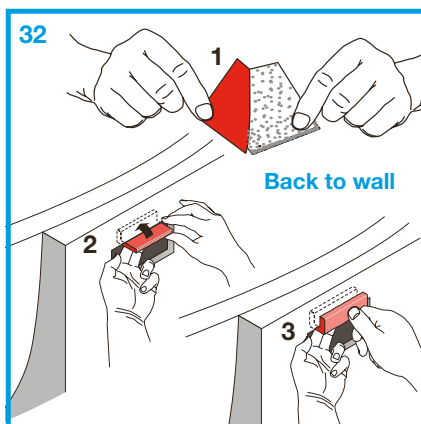
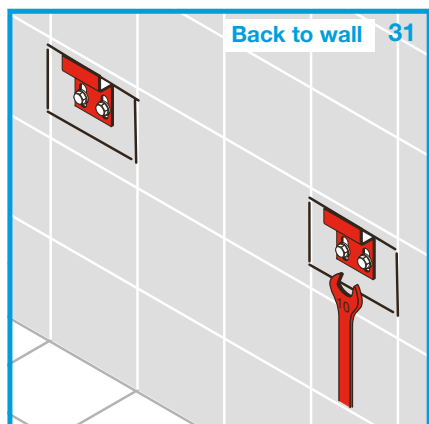

LAUFEN

ILBAGNOALESSI One

FREESTANDING BATH

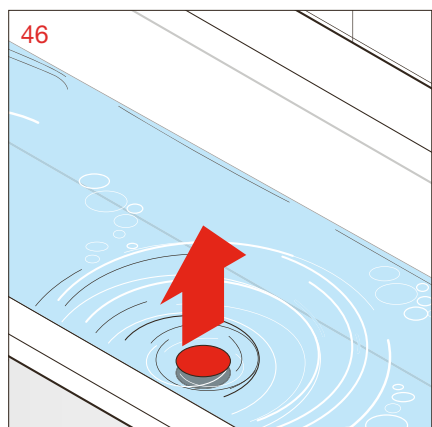
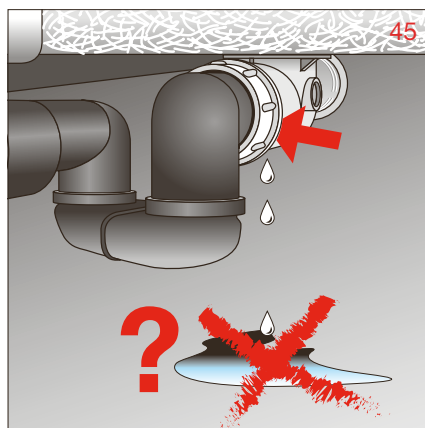
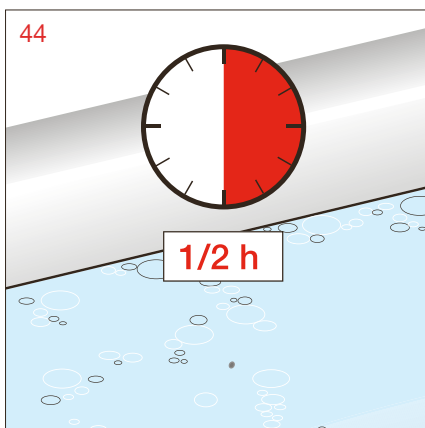
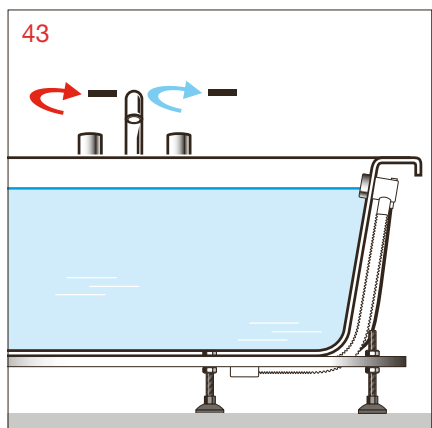
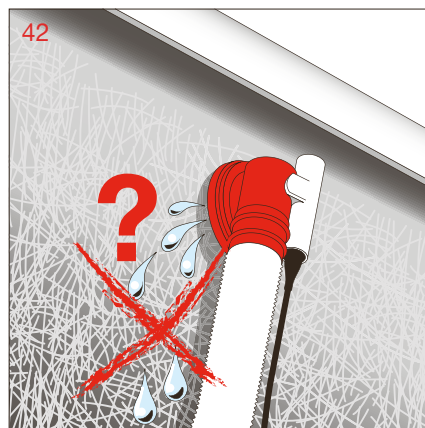
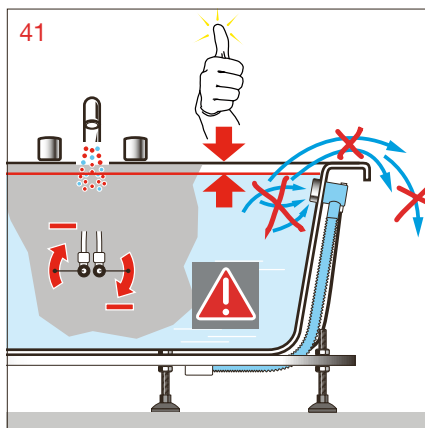
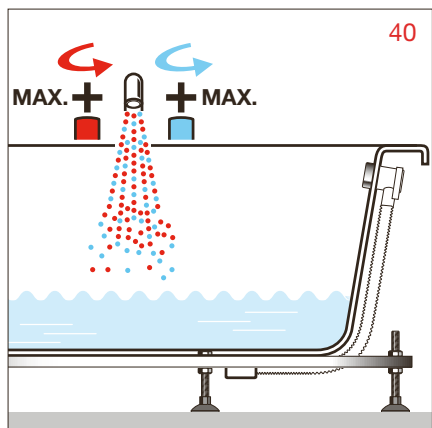

LAUFEN

ILBAGNOLESSI One

FREESTANDING BATH

GENERAL INSTRUCTIONS FOR USE

Let water out after each bath. Never leave children in the tub unsupervised.

Tub maintenance instructions

The surface is simple to clean and maintain. The smooth surface does not absorb much dirt. For regular cleaning we recommend: A sponge, soft cloth and some antistatic cleaning agent. The tub will thus retain its gloss and reject dirt. Rub down, if necessary, with a soft cloth. Avoid the use of abrasives or solvents which damage the surface of the tub. Remove heavy dirt with liquid household cleaner e.g. dishwasher detergents or liquid soap (observe dilution instructions). Remove lime marks with a decalcifier. Always rinse with plenty of clean water. Give a final polish with a soft cloth. Use no acid cleaning agents or cleaning vinegar.

Damage

Scratched surfaces should be treated by the specialist. Buff with a solvent-free polishing paste. If necessary, the surface can firstly be rubbed down with wet emery paper (N°. 800, followed by N°. 1200) before being polished. In no case are alcohol or solvents containing acetone to be used. Damage resulting from inappropriate treatment by the user will not be covered by our guarantee.