



tecumseh

packaged condensing units range.

made like no other.

**it's what's inside
that counts.**

ACPAC range.

ACPAC AP hermetic.

ACPAC APS semi-hermetic.

ACPAC APS semi-hermetic with VSD.

ACPAC A2L hermetic.

COMPAC range.

COMPAC hermetic.

COMPAC scroll.

ACPAC range.

UNDERSTANDING THE ACPAC MODELS

The ACPAC part numbers are based around a nomenclature system, which means there's thought behind the names, making it easy to decipher the model and its attributes.

Please see an example below of an ACPAC model number broken down.

ACPAC
Packaged
Refrigeration
Condensing
Units.

AP S 39.5 ML 2 -1 (XG)

When fitted with FH2 Compressor:

XC = Single Phase

XG = Three Phase

Version

Number of fans

Application

M = Medium Temperature

L = Low Temperature

ML = Medium and Low Temperature

Refrigeration Capacity in kW @ -5 °C SST/32°C
Ambient on R404A

Compressor Type

Blank = Tecumseh hermetic

S = Tecumseh semi hermetic

AP = ACPAC Packaged Refrigeration Condensing Unit

section one

ACPAC AP hermetic.

ACPAC AP hermetic.



ACPAC packaged condensing units offer a complete refrigeration solution.

The ACPAC range is designed in Australia to provide a robust, energy efficient, fully fitted packaged range with world leading hermetically sealed reciprocating and semi hermetic reciprocating compressors.

ACPAC uses premium compressors paired with large condensers to ensure reliable refrigeration when you need it most. This is the ACPAC packaged advantage.

Applications range from supermarket cooling and freezing to refrigeration in convenience stores, pubs, clubs, restaurants, cafés, food processors, and more.

Installation is quick and easy as every ACPAC is fully optioned straight out of the box.

All ACPAC units include condenser fan controls and epoxy coated condenser fins to ensure superb energy efficient performance in Australia's diverse weather conditions.

ACPAC packaged condensing units are a perfect solution for your customers' refrigeration requirements.

Standard features

- World leading Tecumseh hermetic reciprocating compressors
- Large epoxy finned condenser
- Oil Separator on every model
- Suction accumulator on all low temperature models
- Liquid Receiver
- Comprehensive electrical board fully wired to all electrical components
- Safety controls offering substantial protection
- Carel fan speed controller provides stable condenser fan operation in diverse ambient conditions.
- Copper tails for easy connections
- Galvanised powder coated enclosures not only protect the unit but provide a good looking professional finish
- Easy to read wiring diagram is permanently attached to inside panel for convenient reference
- Separate compressor and fan compartments for safe and easy maintenance
- Easy access to all serviceable components

Hermetic Reciprocating.



The Tecumseh hermetic compressor

The hermetic reciprocating compressor range from Tecumseh has built an awesome reputation in the refrigeration industry due to its proven reliability and performance.

The conservative design within this hermetic reciprocating range offers the end user a cost effective refrigeration solution with the benefits of energy efficiency, low noise and reliability.

The Tecumseh compressors are matched with large condensers to provide an ACPAC range with refrigeration capacities from 1.1 to 13.1kW using R404A or common approved HFO/HFC refrigerant blends. The range is also suitable for R134a in many applications, please refer to an Actrol Applications Engineer for specific advice.

The ACPAC hermetic reciprocating range is commonly used for refrigerated cabinets, reach-in and walk-in coolrooms and freezers for every product imaginable including butcher shops, fish shops, fruit and vegetable stores, fast food chains, food processors and many more.

Standard features

- Anti-vibration mounts supplied
- Charged with polyolester oil and dry nitrogen
- Rotalock suction valve on CAJ/TAJ models
- Rotalock suction and discharge valves on FH2 and TAG models
- Crankcase heater on FH2 and TAG models
- Oil sight glass on FH2 and TAG models
- All models suit capillary tube or expansion valve operation
- Improved COP
- Reduced energy consumption
- Reduced sound levels

Medium temperature applications - R404A/R448A/R452A

Single phase

Product Code	Unit Model	Compressor					Fan(s)				Liquid Receiver Capacity kg @ 80%
		Tecumseh Model	Displ. cm ³ /rev	Nominal HP	MOC Amps	Volts / Phase	No. Diam. mm	MOC Amps	Air Flow m ³ /hr	Volts / Phase	
2709753	AP1.7M1-5	CAJ9480Z	15.20	0.7	7.3	240/1	1x 350	0.6	2285	240/1	3.9
2709754	AP2.1M1-5	CAJ9510Z	18.30	1.0	9.2	240/1	1x 350	0.6	2285	240/1	3.9
2709755	AP2.5M1-5	CAJ9513Z	24.20	1.1	12.0	240/1	1x 350	0.6	2285	240/1	3.9
2709756	AP2.8M1-5	CAJ4517Z	25.90	1.5	13.4	240/1	1x 350	0.6	2285	240/1	3.9
2709757	AP3.9M1-5	CAJ4519Z	34.50	1.6	15.6	240/1	1x 350	0.6	2285	240/1	3.9
3508127	AP4.1M1-0-XC	FH4524Z-XC3A	43.50	2.0	15.9	240/1	1x 350	0.6	2285	240/1	3.9

Three phase

Product Code	Unit Model	Compressor					Fan(s)				Liquid Receiver Capacity kg @ 80%
		Tecumseh Model	Displ. cm ³ /rev	Nominal HP	MOC Amps	Volts / Phase	No. Diam. mm	MOC Amps	Air Flow m ³ /hr	Volts / Phase	
3508128	AP5.7M2-0-XG	FH4532Z-XG-1A	56.60	2.6	7.3	415/3	2x 350	1.2	4570	240/1	10
3508129	AP7.8M2-0-XG	FH4538Z-XG-1A	74.20	3.3	8.9	415/3	2x 350	1.2	4570	240/1	10
2709761	AP8.8M2-4	TAG4553Z	100.70	4.4	21.0	415/3	2x 350	1.2	4570	240/1	10
2709762	AP10.7M2-4	TAG4561Z	112.50	5.0	16.3	415/3	2x 350	1.2	4570	240/1	10
2709763	AP13.1M2-4	TAG4573Z	134.80	6.0	21.3	415/3	2x 350	1.2	4570	240/1	10

Dimension properties

Product Code	Unit Model	Unit connections		Weight kg	Sound Power Level dBA	Dimensions			Drawing No.
		Suction	Liquid			L mm	W mm	H mm	
2709753	AP1.7M1-5	5/8"	3/8"	68	62	1070	480	758	1
2709754	AP2.1M1-5	5/8"	3/8"	70	63	1070	480	758	1
2709755	AP2.5M1-5	5/8"	3/8"	70	64	1070	480	758	1
2709756	AP2.8M1-5	5/8"	3/8"	71	65	1070	480	758	1
2709757	AP3.9M1-5	5/8"	3/8"	71	68	1070	480	758	1
3508127	AP4.1M1-0-XC	5/8"	3/8"	81	70	1070	480	758	1
3508128	AP5.7M2-0-XG	5/8"	1/2"	105	69	1284	628	820	2
3508129	AP7.8M2-0-XG	5/8"	1/2"	118	75	1284	628	820	2
2709761	AP8.8M2-4	7/8"	5/8"	146	78	1284	628	820	2
2709762	AP10.7M2-4	7/8"	5/8"	148	78	1284	628	820	2
2709763	AP13.1M2-4	7/8"	5/8"	150	77	1284	628	820	2

ACPAC AP Hermetic.

Medium temperature applications - R404A/R448A/R452A

Capacities

Product Code	Model Number	Ambient Temperature: °C	Capacity: Watts														
			Evaporating Temperature: °C														
			R404A					R448A					R452A				
			-10	-5	0	5	10	-10	-5	0	5	10	-10	-5	0	5	10
2709753	AP1.7MI	30	1457	1763	2106	2486	2902	1387	1710	2076	2487	2944	1437	1751	2104	2497	2929
		32	1406	1702	2033	2400	2801	1335	1648	2003	2401	2844	1384	1687	2028	2407	2824
		38	1253	1519	1814	2141	2499	1192	1477	1799	2162	2565	1230	1502	1808	2147	2521
		43	1125	1366	1632	1926	2248	1075	1337	1633	1966	2337	1101	1349	1625	1932	2270
2709754	AP2.1MI	30	1770	2132	2533	2972	3449	1690	2072	2502	2980	3507	1747	2118	2531	2986	3481
		32	1710	2060	2446	2870	3330	1628	1999	2415	2879	3390	1684	2042	2441	2880	3358
		38	1528	1841	2186	2563	2972	1459	1795	2174	2595	3059	1500	1822	2179	2571	2999
		43	1375	1658	1968	2306	2672	1319	1628	1975	2361	2787	1347	1638	1960	2314	2699
2709755	AP2.5MI	30	2187	2641	3133	3659	4213	2094	2574	3103	3679	4297	2157	2622	3128	3671	4246
		32	2104	2544	3019	3525	4059	2011	2476	2989	3547	4146	2072	2521	3009	3533	4088
		38	1858	2252	2675	3124	3598	1781	2205	2670	3177	3722	1824	2228	2665	3132	3627
		43	1652	2008	2388	2791	3215	1592	1982	2409	2873	3373	1618	1984	2378	2800	3245
2709756	AP2.8MI	30	2406	2866	3363	3894	4454	2299	2791	3332	3921	4555	2370	2842	3356	3906	4490
		32	2320	2764	3243	3755	4295	2213	2690	3214	3785	4400	2281	2737	3232	3763	4327
		38	2061	2458	2884	3337	3815	1974	2408	2884	3403	3961	2021	2431	2873	3346	3848
		43	1844	2203	2584	2988	3414	1778	2177	2613	3088	-	1805	2175	2573	2998	3449
2709757	AP3.9MI	30	3285	3954	4685	5478	6329	3137	3843	4627	5491	6434	3242	3928	4681	5501	6386
		32	3172	3820	4527	5293	6115	3023	3708	4469	5307	6223	3124	3788	4516	5309	6164
		38	2827	3413	4047	4730	5462	2702	3329	4023	4787	5620	2777	3377	4032	4743	5508
		43	2536	3068	3640	4253	4909	2436	3014	3652	4353	5118	2484	3031	3624	4265	4956
3508127	AP4.1MI-0-XC	30															
		32	3625	4422	5290	6227	7230	3462	4302	5235	6262	7381	3567	4382	5273	6238	7273
		38	3168	3885	4663	5500	6396	3036	3802	4652	5589	6611	3106	3843	4646	5513	6444
		43	2796	3447	4149	4903	5709	2695	3400	4182	5044	5986	2733	3406	4135	4921	5766
3508128	AP5.7M2-0-XG	30															
		32	4298	5200	6180	7232	8350	4111	5068	6128	7289	8547	4231	5157	6164	7248	8404
		38	3799	4608	5480	6415	7409	3644	4515	5478	6533	7677	3724	4558	5461	6432	7467
		43	3382	4113	4896	5734	6623	3262	4061	4943	5910	6960	3305	4062	4879	5754	6689
3508129	AP7.8M2-0-XG	30															
		32	5699	6900	8212	9633	11159	5439	6708	8121	9678	11381	5595	6818	8160	9618	11191
		38	5055	6145	7326	8600	9967	4838	6006	7300	8726	10285	4958	6068	7279	8591	10006
		43	4510	5507	6581	7733	8967	4338	5422	6620	7938	9380	4423	5437	6538	7729	9012
2709761	AP8.8M2	30	7404	9065	10855	12756	14750	7128	8883	10817	12916	15166	7311	9006	10845	12811	14883
		32	7083	8688	10415	12248	14171	6804	8504	10377	12413	14596	6978	8616	10392	12288	14289
		38	6128	7567	9107	10738	12447	5905	7450	9151	11001	12990	6021	7492	9081	10776	12567
		43	5342	6646	8032	9495	11027	5175	6595	8155	9853	-	5236	6571	8006	9535	-
2709762	AP10.7M2	30	8578	10456	12492	14668	16964	8234	10216	12409	14803	17381	8468	10388	12481	14731	17117
		32	8230	10046	12012	14112	16327	7883	9805	11931	14252	16755	8107	9963	11985	14158	16463
		38	7190	8825	10584	12456	14430	6909	8663	10599	12714	14999	7064	8738	10553	12501	14569
		43	6326	7816	9406	11092	12866	6111	7732	9516	11464	13570	6200	7728	9375	11139	13010

Capacities

Product Code	Model Number	Ambient Temperature: °C	Capacity: Watts														
			Evaporating Temperature: °C														
			R404A					R448A					R452A				
			-10	-5	0	5	10	-10	-5	0	5	10	-10	-5	0	5	10
2709763	API3.1M2	30	10417	12488	14707	17052	19499	10008	12232	14670	17307	20124	10277	12403	14696	17133	19691
		32	10023	12026	14167	16428	18787	9612	11770	14135	16694	19430	9867	11923	14137	16490	18961
		38	8829	10625	12534	14544	16639	8498	10466	12621	14954	17453	8668	10515	12498	14603	16814
		43	7826	9447	11162	12962		7576	9386	11367	-	-	7663	9336	11126	13024	-

Capacities based on EN13215 Midpoint ratings: Return Vapour 20°C, Subcooling 3K

ACPAC AP Hermetic.

Dimensional Drawings

ACPAC Hermetic MT (Small)

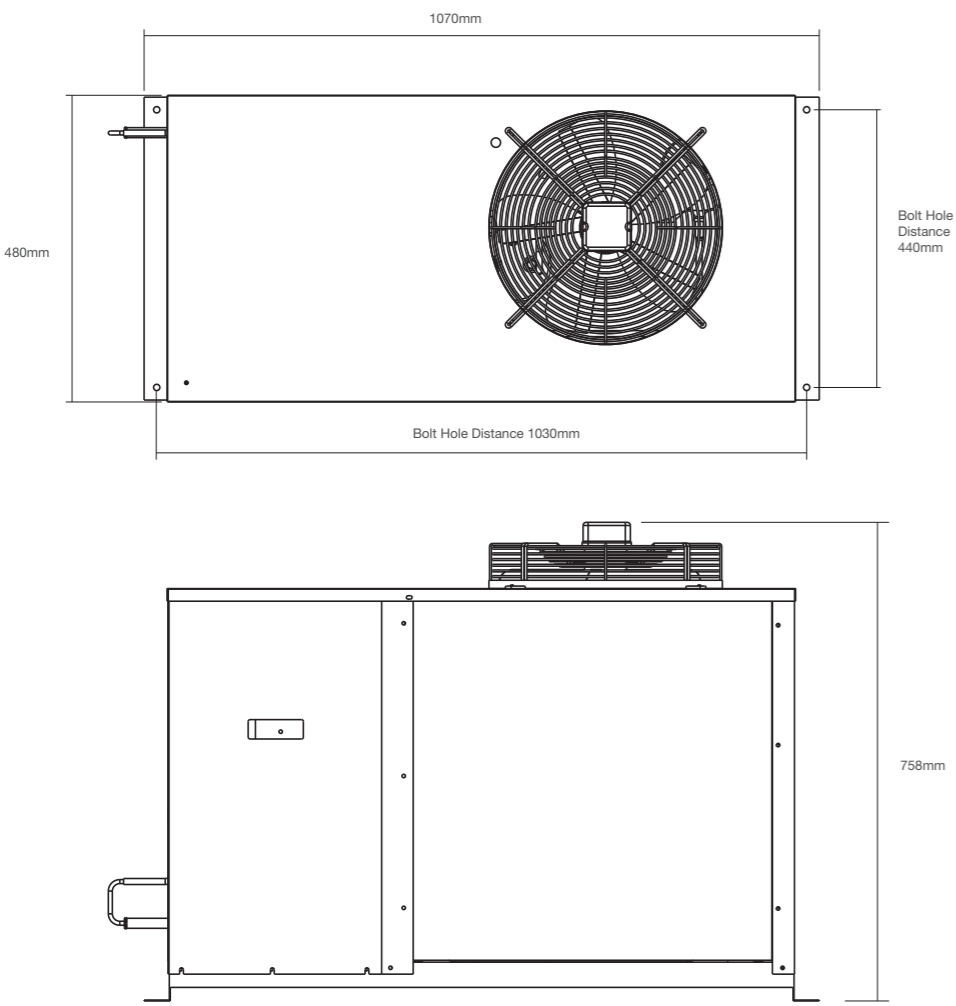

ACPAC Hermetic MT (Medium)

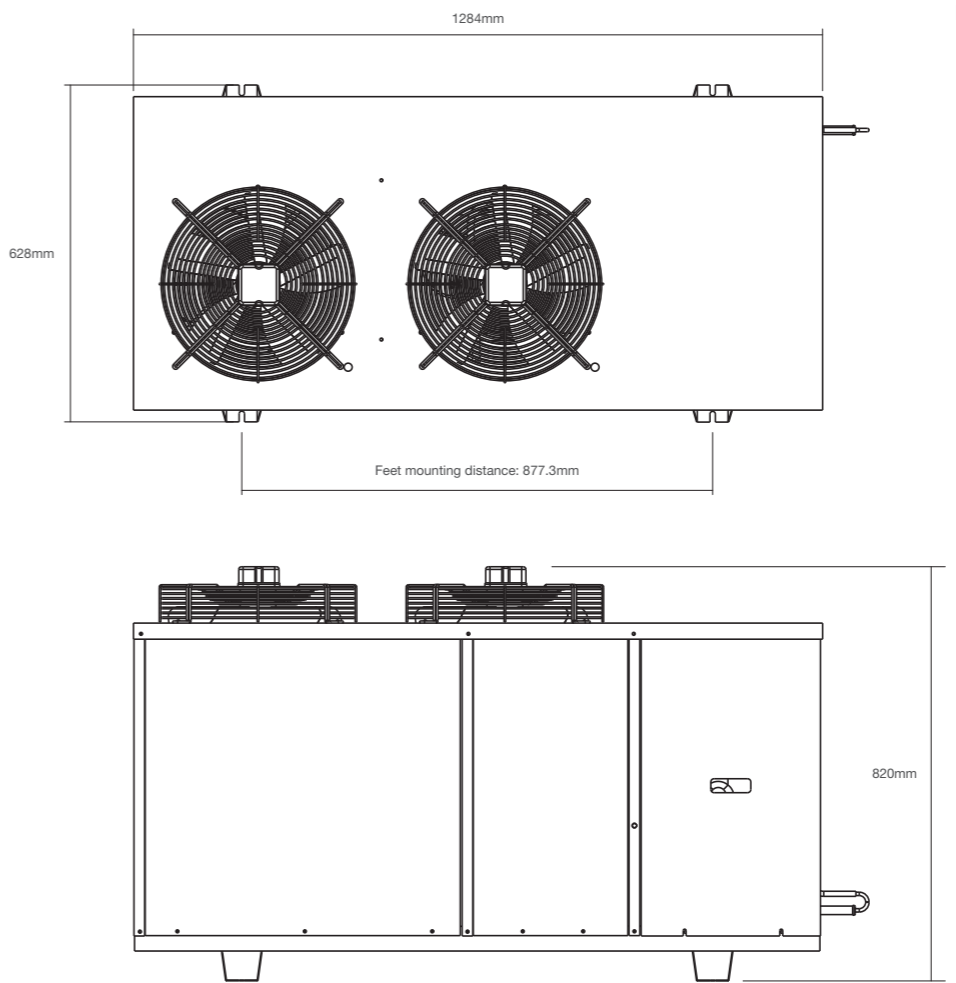

section two

ACPAC APS semi-hermetic.

ACPAC APS semi-hermetic.



ACPAC APS packaged condensing units offer a complete refrigeration solution.

The ACPAC range is designed in Australia to provide a robust energy efficient, fully fitted packaged range with world leading semi hermetic reciprocating compressors.

ACPAC uses premium compressors and large condensers in combination to ensure reliable refrigeration when you need it most. This is the ACPAC packaged advantage.

Applications are diverse and include commercial food, beverage cooling, and freezing in supermarkets, as well as refrigeration applications in convenience stores, pubs and clubs, restaurants, cafés, food processors and many more.

Installation is quick and easy as every ACPAC is fully optioned straight out of the box.

All ACPAC units include condenser fan controls and epoxy coated condenser fins to ensure superb energy efficient performance in Australia's diverse weather conditions.

ACPAC packaged condensing units are a perfect solution for your customers' refrigeration requirements.

Standard features

- World leading compressors
- Large epoxy finned condenser/s
- Oil Separator on every model
- Suction Accumulator on most models
- Liquid Receiver
- Comprehensive electrical board fully wired to all electrical components
- Safety controls offering substantial protection
- Condenser fan control provides stable operation in Australia's diverse weather conditions
- Copper tails for easy connections
- Galvanised powder coated enclosures not only protect the unit but provide a good looking professional finish every time
- Easy to read wiring diagram is permanently attached to inside panel for quick service
- Separate compressor and fan compartments for safe and easy maintenance
- Easy access to all serviceable components

Semi hermetic reciprocating.



The SH semi hermetic compressor from Tecumseh has a proven reputation for performance and reliability in refrigeration. manufactured in Italy the SH compressors are both quiet and energy efficient.

The APS ACPAC range has been designed to operate efficiently in both the hot and cold extremes of the Australian environment with large condensers and fan speed control across all models.

The ACPAC APS range available in capacities from 1.8 to 64.2kW is suitable for R134a, R404A and common compatible HFO/HFC refrigerant blends and can be applied in both medium and low temperature applications.

The APS ACPAC with the Tecumseh semi hermetic compressor is suited to an enormous range of refrigeration applications including reach-in and walk-in coolrooms and freezers for food, beverages and other stored products.

Typical applications are supermarkets, fast food outlets, pubs and clubs, restaurants and liquor stores.

Standard features

- Tecumseh SH semi-hermetic reciprocating compressor
- Kriwan INT69, INT69 Diagnose or INT TML Diagnose protection module fitted depending on compressor model
- Part Winding Start (PWS) on larger models
- Compressor thermal overload protection on all three phase models
- Cable numbering to make maintenance even easier
- Oil separator isolation valve
- Sump heaters as standard
- Flexible control lines
- Suction demountable drier shell with filter core fitted
- Removable compressor transport mounts to protect pipework during transit
- EC condenser fans on some larger models

Medium / low temperature applications – R404A/R448A/R452A/R134a/R513A

Three phase

Product Code	Unit Model	Compressor						Fan(s)				Liquid Receiver Capacity kg @ 80%
		Tecumseh Model	Displ. m ³ /hr	Nominal HP	Motor Type	MOC Amps	Volts / Phase	No. Diam. Mm	MOC Amps	Air Flow m ³ /hr	Volts / Phase	
2701982	APS4.6ML2-1	SH4526ZY	6.91	2.2	DOL	4.5	415/3	2x 350	1.4	4210	240V/1	10.0
2701983	APS6.0ML2-1	SH4536ZY	9.88	3.0	DOL	6.7	415/3	2x 350	1.4	4210	240V/1	10.0
2701984	APS8.3ML2-1	SH4550ZY	13.15	4.0	DOL	8.8	415/3	2x 350	1.4	4210	240V/1	10.0
2701985	APS11.7ML3-1	SH4567ZY	17.93	5.0	DOL	12.5	415/3	3x 350	2.1	6315	240V/1	10.0
With VSD-Ready Case												
3508157	APS14.4ML3-1	SH4591ZY	24.69	7.0	DOL	12.7	415/3	3x 350	2.1	6315	240V/1	10.0
3508158	APS19.0ML2-1	SH4610ZY	28.02	8.0	DOL	17.6	415/3	2x 500	6.0	11530	240V/1	12.0
3508159	APS25.8ML2-1	SH4615ZMZ	41.32	12.0	PWS	22.4	415/3	2x 500	6.0	11530	240V/1	12.0
3508160	APS33.6ML2-1	SH4620ZMZ	51.50	15.0	PWS	32.4	415/3	2x 500	6.0	11530	240V/1	12.0
3508168	APS38.2ML2-1	SH4622ZMZ	56.00	20.0	PWS	33.0	415/3	2x 500	6.0	11530	240V/1	12.0
3508161	APS46.5ML2-1	SH4627ZMZ	70.77	25	PWS	43.5	415/3	2x 710	3.8	25060	415V/3	25.0
3508162	APS56.4ML2-1	SH4632ZMZ	83.81	30	PWS	49.2	415/3	2x 710	3.8	25060	415V/3	25.0
3508163	APS64.2ML2-1	SH4639ZMZ	102.86	35	PWS	61.0	415/3	2x 710	3.8	25060	415V/3	25.0

Dimension properties

Product Code	Unit Model	Unit connections		Weight kg	Sound Power Level dBA	Dimensions			Drawing No.	
		Suction	Liquid			L mm	W mm	H mm		
2701982	APS4.6ML2-1	7/8"	1/2"	161	65	1425	630	772	3	
2701983	APS6.0ML2-1	7/8"	1/2"	168	67	1425	630	772	3	
2701984	APS8.3ML2-1	7/8"	1/2"	180	67	1425	630	772	3	
2701985	APS11.7ML3-1	1-1/8"	1/2"	195	70	1885	630	772	4	
With VSD-Ready Case										
3508157	APS14.4ML3-1	1-1/8"	1/2"	240	70	1885	630	772	4	
3508158	APS19.0ML2-1	1-3/8"	5/8"	290	72	1779	870	1014	5	
3508159	APS25.8ML2-1	1-3/8"	5/8"	340	75	1779	870	1014	5	
3508160	APS33.6ML2-1	1-3/8"	5/8"	386	77	1779	870	1014	5	
3508168	APS38.2ML2-1	1-3/8"	5/8"	392	77	1779	870	1014	5	
3508161	APS46.5ML2-1	2-1/8"	1-1/8"	615	78	2455	1101	1542	6	
3508162	APS56.4ML2-1	2-1/8"	1-1/8"	650	81	2455	1101	1542	6	
3508163	APS64.2ML2-1	2-1/8"	1-1/8"	670	82	2455	1101	1542	6	

VSD-Ready Casing

ACPAC units equipped with VSD-Ready cases are supplied with a purpose-built compartment designed to house a Vacon Variable Speed Drive (VSD).

Please note: The unit is not supplied with a VSD.

This compartment allows the VSD to be installed neatly inside the unit, with the controls and display mounted flush and accessible from the side of the ACPAC enclosure. This design gives customers the option to install a VSD if required for their application. When a VSD is installed, capacity data at 30Hz, 50Hz and 60Hz is provided to support system design and selection.

If a VSD is not installed, the unit operates as a standard fixed-speed system, and customers should refer to the 50Hz capacity ratings.

ACPAC APS semi-hermetic.

Capacities - R404A

(30/60 Hz values apply only when an optional, field-installed VSD is used. Otherwise, refer to 50 Hz values)

Product Code	Model Number	Frequency	Ambient Temperature: °C	Capacity: Watts							
				Evaporating Temperature: °C							
				R404A							
				-30	-25	-20	-15	-10	-5	0	5
2701982	APS4.6ML2-1	50Hz	30	1627	2133	2732	3431	4233	5141	6160	7291
			32	1566	2055	2635	3311	4088	4971	5961	7062
			38	1391	1830	2351	2962	3667	4470	5376	6387
			43	1245	1644	2118	2675	3321	4059	4895	5833
2701983	APS6.0ML2-1	50Hz	30	2306	2962	3725	4600	5588	6693	7915	9255
			32	2229	2865	3604	4450	5408	6480	7666	8967
			38	2008	2582	3249	4014	4880	5850	6928	8114
			43	1834	2358	2965	3661	4451	5337	6325	7414
2701984	APS8.3ML2-1	50Hz	30	3132	4076	5152	6368	7729	9239	10900	12711
			32	3012	3933	4978	6157	7476	8938	10545	12299
			38	2666	3518	4474	5543	6733	8051	9500	11082
			43	2395	3190	4071	5049	6133	7331	8647	10085
2701985	APSI1.7ML3-1	50Hz	30	4675	5909	7315	8899	10666	12617	14751	-
			32	4533	5732	7096	8630	10340	12227	14291	-
			38	4123	5214	6446	7827	9361	11053	12905	-
			43	3807	4803	5920	7167	8551	10076	11748	-
ACPAC VSD-Ready Case Units											
3508157	APSI4.4ML3-1V	30HZ	30	3394	4397	5571	6954	8536	10353	12429	-
			32	3274	4248	5398	6737	8280	10024	12049	-
			38	2922	3813	4857	6067	7468	9068	10881	-
			43	2615	3449	4412	5527	6810	8253	-	-
		50Hz	30	5829	7456	9320	11426	13769	16345	19144	-
			32	5621	7202	9009	11046	13312	15801	18506	-
			38	4995	6439	8074	9906	11938	14168	16592	-
			43	4470	5800	7292	8954	10791	12805	-	-
		60Hz	30	6751	8593	10675	12976	15484	-	-	-
			32	6503	8293	10311	12554	14963	-	-	-
			38	5772	7388	9215	11199	13353	-	-	-
			43	-	-	-	-	-	-	-	-

Product Code	Model Number	Frequency	Ambient Temperature: °C	Capacity: Watts							
				Evaporating Temperature: °C							
				R404A							
				-30	-25	-20	-15	-10	-5	0	5
3508158	APSI9.0ML2-1V	30HZ	30	4523	5870	7457	9310	11468	13947	16770	19913
			32	4381	5684	7226	9033	11110	13527	16284	19386
			38	3929	5135	6543	8198	10091	12306	14823	17662
			43	3551	4679	5976	7497	9234	11276	13582	16172
		50Hz	30	7188	9243	11624	14354	17451	20932	24807	-
			32	6945	8945	11258	13906	16910	20285	24044	-
			38	6215	8052	10159	12563	15285	18344	21756	-
			43	5600	7300	9236	11436	13924	16720	19842	-
		60Hz	30	8437	10814	13545	16631	20121	23973	28125	-
			32	8155	10458	13095	16104	19411	23194	27299	-
			38	7283	9400	11790	14521	17523	20898	-	-
			43	6560	8524	10716	13204	15921	19007	-	-
30HZ	30	5371	6940	8757	10831	13055	15644	18503	-		
	32	5157	6679	8443	10363	12621	15139	17918	-		
	38	4503	5907	7513	9262	11323	13628	16183	-		
	43	4007	5276	6749	8356	10254	12384	14750	-		
50Hz	30	9749	12608	15916	19690	23943	28684	33917	-		
	32	9357	12133	15344	19010	23144	27756	32850	-		
	38	8201	10725	13648	16989	20765	24988	29667	-		
	43	7260	9574	12254	15324	18801	22700	27033	-		
60Hz	30	11667	15074	19022	23526	28359	33982	40192	-		
	32	11201	14509	18340	22510	27416	35886	38922	-		
	38	9782	12832	16319	20119	24597	29602	35153	-		
	43	8705	11461	14660	18151	22274	26901	-	-		
30HZ	30	7878	10018	12498	15355	18669	22481	26807	31738		
	32	7613	9734	12140	14918	18131	21874	26135	30932		
	38	6800	8801	11058	13640	16559	19961	23860	28261		
	43	6137	8041	10143	12533	15245	18379	21885	25839		
50Hz	30	13651	17273	21339	25911	31044	36779	43150	50175		
	32	13178	16735	20704	25152	30134	35694	41867	48676		
	38	11734	15095	18780	22857	27388	32426	38011	44176		
	43	10503	13705	17154	20926	25086	29692	34792	40427		
60Hz	30	15871	20023	24665	29793	35476	41737	-	-		
	32	15325	19407	23884	28905	34378	40440	-	-		
	38	13602	17446	21610	26182	31127	36526	-	-		
	43	-	15817	19710	23900	28451	-	-	-		

ACPAC APS semi-hermetic.

Capacities - R404A

(30/60 Hz values apply only when an optional, field-installed VSD is used. Otherwise, refer to 50 Hz values)

Product Code	Model Number	Frequency	Ambient Temperature: °C	Capacity: Watts								
				Evaporating Temperature: °C								
				R404A								
				-30	-25	-20	-15	-10	-5	0	5	
3508168	APS38.2ML2-IV	30Hz	30	8505	10808	13472	16507	19951	23976	28443	33524	
			32	8083	10272	12764	15577	18769	22386	26439	30986	
			38	7193	9279	11580	14169	17074	20352	24027	28127	
		43	6425	8410	10581	12978	15650	18640	21989	25733		
		50Hz	30	14768	18652	23053	27955	33302	39386	45868	53145	
			32	14265	18086	22340	27068	32317	38120	44498	51462	
	38		12665	16285	20199	24512	29291	34491	40195	46430		
	60Hz	30	17202	21688	26694	32164	38082	44731	51702	67248		
		32	16727	21190	26103	31524	37451	43937	51055	57478		
		38	14841	19034	23582	28504	33873	39772	45542	49961		
		43	13233	17200	21481	25995	30933	36238	41029	44292		
		3508161	APS46.5ML2-IV	30Hz	30	10061	13103	16713	20968	25984	31675	38219
32					9688	12625	16139	20315	25144	30661	37104	44357
38	8554				11249	14461	18228	22606	27687	33586	40245	
43	8039			10100	13066	16548	20555	25291	30632	36753		
50Hz	30			17231	22179	27917	34485	41910	50213	59400	69474	
	32			16565	21371	26937	33304	40504	48557	57476	67264	
	38		14588	18973	24026	29797	36323	43634	51751	60687		
60Hz	30		19941	25538	31960	39165	47334	56106	-	-		
	32		19181	24588	30770	37806	45663	54166	-	-		
	38		16848	21793	27460	33769	40791	48532	-	-		
	43		-	-	-	30408	36854	-	-	-		
	3508162		APS56.4ML2-IV	30Hz	30	11518	14771	18541	22848	27715	33151	39163
		32			11093	14254	17914	22094	26814	32091	37936	44347
38		9851			12727	16051	19849	24143	28951	34286	40160	
43		8850		11490	14530	18007	21941	26358	31271	-		
50Hz		30		21158	27120	34024	41913	50822	60774	71783	83856	
		32		20379	26170	32870	40527	49175	58840	69540	81285	
		38	18093	23366	29453	36407	44270	53074	62845	73601		
60Hz		30	16251	21087	26659	33024	40228	48311	57306	67237		
		30	25020	32086	40274	49630	60203	72012	85070	99383		
		32	24097	30963	38912	47993	58245	69708	82405	96331		
		38	21399	27645	34867	43117	52443	62887	74476	-		
		43	19225	24958	31562	39115	47660	57225	-	-		
	3508163	APS64.2ML2-IV	30Hz	30	14334	18460	23097	28313	34237	40877	48316	56610
32				13807	17850	22353	27439	33132	39587	46774	54782	
38				12155	15935	20117	24757	29960	35804	42344	49574	
43			10734	14360	18306	22639	27430	32873	38871	45591		
50Hz			30	25728	32642	40435	49158	58849	69528	81206	93881	
			32	24777	31529	39111	47580	56976	67326	78644	90935	
		38	21853	28174	35180	42939	51505	60918	71207	82394		
60Hz		30	19434	25458	32045	39273	47206	55895	65383	-		
		30	30225	38234	47265	57250	68269	80325	93300	-		
		32	29106	36983	45677	55447	66073	77677	-	-		
		38	25650	32971	41079	49956	59684	70370	-	-		
		43	22712	29828	37388	45779	54758	-	-	-		

Additional compressor cooling required
Capacities based on EN13215 Midpoint ratings: Return Vapour 20°C, Subcooling 3K

Capacities - R448A

(30/60 Hz values apply only when an optional, field-installed VSD is used. Otherwise, refer to 50 Hz values)

Product Code	Model Number	Frequency	Ambient Temperature: °C	Capacity: Watts							
				Evaporating Temperature: °C							
				R448A							
				-30	-25	-20	-15	-10	-5	0	5
2701982	APS4.6ML2-1	50Hz	30	1353	1834	2407	3087	3874	4776	5811	6955
			32	1300	1769	2326	2983	3747	4624	5632	6762
			38	1134	1569	2082	2680	3379	4187	5107	6148
			43	996	1405	1875	2434	3078	3821	4674	5642
			30	2067	2748	3548	4475	5540	6749	8106	9616
2701983	APS6.0ML2-1	50Hz	32	1987	2650	3426	4326	5359	6532	7851	9319
			38	1738	2347	3054	3873	4813	5882	7086	8430
			43	1522	2087	2740	3492	4356	5339	6449	7691
			30	2898	3806	4873	6110	7559	9217	11120	13229
2701984	APS8.3ML2-1	50Hz	32	2804	3682	4721	5934	7341	8961	10800	12896
			38	2498	3317	4275	5396	6697	8209	9918	11870
			43	2243	3010	3899	4933	6160	7566	9183	11003
2701985	APSI1.7ML3-1	50Hz	30	4308	5561	7028	8734	10706	12964	15526	18406
			32	4159	5379	6807	8470	10393	12597	15102	17921
			38	3716	4838	6152	7685	9463	11510	13844	16482
ACPAC VSD-Ready Case Units											
3508157	APSI4.4ML3-IV	30Hz	30	2964	3922	5072	6467	8103	10049	12343	-
			32	2855	3792	4924	6277	7893	9783	12046	-
			38	2548	3411	4453	5702	7202	8978	11066	-
			43	2293	3096	4074	5238	6650	8305	10200	-
		50Hz	30	5129	6714	8582	10764	13289	16167	19459	-
			32	4940	6483	8302	10426	12872	15702	18929	-
			38	4396	5824	7489	9447	11703	14324	17292	-
			43	3957	5280	6824	8646	10742	13194	-	-
		60Hz	30	5956	7772	9868	12290	15015	-	-	-
			32	5738	7497	9563	11929	14599	-	-	-
			38	5108	6712	8606	10747	13218	-	-	-
			43	-	-	-	-	-	-	-	-
3508158	APSI9.0ML2-IV	50Hz	30	3951	5236	6790	8659	10887	13538	16655	20264
			32	3821	5075	6592	8417	10592	13202	16280	19857
			38	3427	4594	5999	7706	9732	12184	15076	18439
			43	3115	4201	5519	7105	9018	11348	14080	17231
60Hz	30	6326	8324	10704	13523	16843	20705	25216	-		
	32	6104	8052	10375	13126	16352	20159	24594	-		
	38	5470	7283	9424	11982	14985	18546	22675	-		
	43	4958	6646	8644	11043	13862	17228	21085	-		
60Hz	30	7444	9781	12522	15752	19512	23911	28899	-		
	32	7196	9455	12146	15303	18940	23252	28161	-		
	38	6446	8541	11012	13936	17347	21373	-	-		
	43	5831	7809	10104	12841	16040	19837	-	-		

ACPAC APS semi-hermetic.

Capacities - R448A

(30/60 Hz values apply only when an optional, field-installed VSD is used. Otherwise, refer to 50 Hz values)

Product Code	Model Number	Frequency	Ambient Temperature: °C	Capacity: Watts							
				Evaporating Temperature: °C							
				R448A							
				-30	-25	-20	-15	-10	-5	0	5
3508159	APS25.8ML2-IV	30Hz	30	5361	6708	8266	10397	12765	15601	18858	22115
			32	5180	6764	8019	9995	12396	15145	18323	21501
			38	4641	5636	7262	9072	11299	13853	16817	19781
			43	4198	5123	6628	8351	10404	12797	15570	18343
		50Hz	30	9495	12383	15788	19783	24432	29789	35899	42796
			32	9145	11953	15263	19148	23674	28897	34862	41606
			38	8113	10689	13719	17280	21442	26265	31799	38085
			43	7269	9658	12461	15758	19623	24117	29297	35207
		60Hz	30	11646	14570	18295	22999	28268	34608	41832	49056
			32	11252	14693	17737	22125	27483	36750	40755	44760
			38	10082	12472	16091	20176	25068	30842	36616	42390
			43	9119	11325	14700	18549	23143	28531	33919	39307
3508160	APS33.6ML2-IV	30Hz	30	6025	8052	10509	13468	17028	21209	26124	31761
			32	5796	7786	10179	13059	16508	20630	25469	31036
			38	5117	6945	9160	11835	15006	18828	23365	28603
			43	4557	6270	8300	10815	13782	17337	21530	26390
		50Hz	30	10535	13966	18054	22880	28536	35059	42547	51138
			32	10142	13504	17466	22139	27651	34062	41401	49705
			38	8938	12028	15679	20022	25063	30943	37794	45608
			43	7975	10840	14207	18247	22920	28427	33843	-
		60Hz	30	12315	16279	20946	26416	32737	40013	-	-
			32	11842	15724	20248	25544	31749	38814	-	-
			38	10434	13990	18167	23075	28724	35220	-	-
			43	-	12600	16422	20970	26184	-	-	-
3508168	APS38.2ML2-IV	30Hz	30	6926	9125	11803	14970	18678	23132	28168	34147
			32	6570	8657	11162	14111	17573	21628	26286	31620
			38	5839	7783	10062	12794	15974	19729	24075	29025
			43	5226	7037	9162	11687	14647	18163	22198	26821
		50Hz	30	12145	15879	20345	25498	31473	38471	46187	55025
			32	11712	15372	19683	24695	30511	37297	44894	53605
			38	10437	13811	17720	22312	27756	33830	41010	48933
			43	9363	12483	16145	20432	25392	31131	37727	43995
		60Hz	30	14205	18518	23621	29463	36194	43913	52456	61846
			32	13812	18088	23088	28887	35645	43151	51632	60987
			38	12306	16234	20791	26114	32274	39393	47327	55498
			43	10986	14663	18894	23839	29596	36127	42841	49739

Product Code	Model Number	Frequency	Ambient Temperature: °C	Capacity: Watts							
				Evaporating Temperature: °C							
				R448A							
				-30	-25	-20	-15	-10	-5	0	5
3508161	APS46.5ML2-IV	30Hz	30	9477	12491	16116	20436	25636	31655	38811	47047
			32	9172	12105	15656	19920	24966	30889	37902	46076
			38	8222	10969	14285	18243	22908	28464	35053	42619
			43	7832	10042	13124	16809	21188	26452	32573	39695
		50Hz	30	16463	21477	27437	34387	42510	51644	62125	74043
			32	15902	20833	26625	33419	41242	50287	60572	72279
			38	14232	18803	24205	30471	37655	46085	55709	65821
			43	12802	17146	22166	27997	34729	42572	50808	59439
		60Hz	30	19154	24926	31706	39447	48511	58454	-	-
			32	18510	24159	30707	38364	47105	56841	-	-
			38	16548	21769	27885	34920	42853	51953	-	-
			43	-	-	-	31997	39365	-	-	-
3508162	APS56.4ML2-IV	30Hz	30	11566	14944	18878	22631	28682	34645	41366	48789
			32	11208	14504	18342	22789	27894	33714	40277	47534
			38	10090	13176	16710	20809	25520	30900	36987	43735
			43	9215	12056	15337	19142	23519	28531	34217	40522
		50Hz	30	20507	26517	33515	41613	50900	61453	73330	86571
			32	19814	25671	32482	40359	49395	59669	71241	84154
			38	17727	23120	29365	36577	44859	54293	64950	76882
			43	15992	20992	26759	33414	41064	49798	59694	70810
		60Hz	30	25124	32	41007	49160	62303	75256	89856	105979
			32	24345	31506	39842	49503	60592	73235	87491	103253
			38	21917	28620	36297	45201	55434	67121	80343	95001
			43	20016	26189	33316	41580	51088	61975	74326	-
3508163	APS64.2ML2-IV	30Hz	30	13268	17248	21938	27287	33464	40652	48821	58156
			32	12877	16790	21378	26593	32599	39542	47534	56610
			38	11671	15343	19622	24426	29972	36389	43731	52064
			43	10592	14107	18098	22619	27799	33765	40604	48396
		50Hz	30	24045	30900	38823	47960	58386	70247	83361	98213
			32	23362	30087	37786	46690	56827	68286	81220	95599
			38	21202	27504	34672	42826	52121	62684	74542	87756
			43	19361	25295	31954	39636	48161	58004	68908	81004
		60Hz	30	28391	36430	45642	56152	68128	81677	96562	112865
			32	27559	35444	44390	54686	66342	79362	93790	109488
			38	24999	32363	40700	50133	60776	72793	86099	100779
			43	22749	29764	37552	46274	56122	67124	79468	92924

Additional compressor cooling required
Capacities based on EN13215 Midpoint ratings: Return Vapour 20°C, Subcooling 3K

ACPAC APS semi-hermetic.

Capacities - R452A

(30/60 Hz values apply only when an optional, field-installed VSD is used. Otherwise, refer to 50 Hz values)

Product Code	Model Number	Frequency	Ambient Temperature: °C	Capacity: Watts							
				Evaporating Temperature: °C							
				R452A							
				-30	-25	-20	-15	-10	-5	0	5
2701982	APS4.6ML2-1	50Hz	30	1504	1976	2554	3243	4045	4963	6000	7157
			32	1442	1899	2460	3125	3903	4796	5803	6928
			38	1267	1678	2183	2786	3492	4304	5225	6258
			43	1123	1501	1963	2515	3163	3911	4762	5720
2701983	APS6.0ML2-1	50Hz	30	2184	2814	3567	4444	5446	6574	7825	9197
			32	2106	2715	3442	4290	5259	6351	7564	8896
			38	1877	2424	3076	3839	4713	5700	6801	8013
			43	1694	2192	2786	3480	4278	5180	6190	7305
2701984	APS8.3ML2-1	50Hz	30	2893	3776	4816	6018	7386	8918	10618	12478
			32	2773	3637	4647	5812	7137	8621	10265	12067
			38	2430	3231	4157	5214	6411	7751	9235	10861
			43	2585	3051	3779	4750	5842	7063	8411	9891
2701985	APS11.7ML3-1	50Hz	30	4311	5473	6838	8410	10190	12177	14366	16555
			32	4168	5298	6623	8146	9869	11791	13908	16025
			38	3760	4791	5990	7363	8912	10639	12542	14445
			43	3460	4405	5498	6742	8145	9705	11427	13149
ACPAC VSD-Ready Case Units											
3508157	APS14.4ML3-1V	30Hz	30	3133	4074	5209	6572	8156	9993	12106	-
			32	3014	3928	5040	6359	7904	9669	11728	-
			38	2664	3501	4513	5708	7111	8730	10578	-
			43	2358	3155	4093	5198	6487	7950	9433	-
		50Hz	30	5381	6907	8714	10799	13157	15777	18646	-
			32	5175	6660	8410	10428	12708	15241	18014	-
			38	4552	5913	7501	9320	11369	13641	16129	-
			43	4033	5307	6765	8422	10279	12336	-	-
		60Hz	30	6232	7961	9980	12264	14795	-	-	-
			32	5986	7668	9625	11852	14284	-	-	-
			38	5260	6785	8562	10536	12716	-	-	-
			43	-	-	-	-	-	-	-	-
3508158	APS19.0ML2-1V	50Hz	30	4174	5437	6971	8799	10958	13462	16335	19548
			32	4032	5255	6746	8528	10605	13046	15850	19020
			38	3581	4716	6080	7713	9610	11848	14408	17310
			43	3024	4285	5545	7052	8797	10863	13213	15863
60Hz	30	6633	8564	10866	13567	16675	20204	24162	-		
	32	6392	8270	10509	13128	16143	19566	23405	-		
	38	5665	7395	9439	11820	14556	17661	21148	-		
	43	4799	6685	8571	10757	13265	16108	19302	-		
3508159	APS25.8ML2-1V	50Hz	30	7786	10017	12662	15719	19226	23139	27395	-
			32	7506	9669	12224	15202	18530	22372	26573	-
			38	6637	8633	10955	13663	16687	20120	-	-
			43	5668	7807	9945	12421	15166	18311	-	-

Product Code	Model Number	Frequency	Ambient Temperature: °C	Capacity: Watts							
				Evaporating Temperature: °C							
				R452A							
				-30	-25	-20	-15	-10	-5	0	5
3508159	APS25.8ML2-1V	30Hz	30	4958	6429	8188	10238	12475	15101	18022	20943
			32	4748	6176	7882	9785	12050	14604	17443	20282
			38	4100	5421	6980	8715	10787	13123	15733	18343
			43	3380	4672	6257	7858	9769	11932	14349	16766
		50Hz	30	9001	11681	14881	18612	22880	27689	33035	38381
			32	8616	11219	14326	17949	22098	26774	31979	37184
			38	7469	9844	12679	15988	19781	24065	28843	33621
			43	6137	8482	11361	14411	17912	21873	26299	30725
		60Hz	30	10773	13966	17786	22238	27100	32803	39147	45491
			32	10314	13416	17123	21255	26177	31618	37890	44162
			38	8908	11778	15161	18934	23432	28508	34176	39844
			43	7341	10148	13591	17070	21221	25921	-	-
3508160	APS33.6ML2-1V	30Hz	30	7263	9278	11682	14510	17836	21701	26115	31162
			32	7002	8999	11331	14079	17305	21097	25443	30354
			38	6202	8089	10277	12834	15766	19215	23193	27700
			43	5225	7221	9426	11794	14522	17703	21288	25344
		50Hz	30	12586	15997	19946	24485	29659	35502	42035	49265
			32	12119	15470	19324	23739	28762	34427	40758	47767
			38	10702	13874	17456	21505	26076	31214	36948	43299
			43	8836	12212	15942	19693	23896	28600	33842	39654
		60Hz	30	14634	18546	23054	28152	33894	40288	-	-
			32	14095	17941	22294	27282	32812	39004	-	-
			38	12405	16035	20086	24633	29636	35161	-	-
			43	-	22031	28760	34204	40310	-	-	-
3508168	APS38.2ML2-1V	30Hz	30	7842	10010	12592	15599	19060	23143	27707	32916
			32	7434	9496	11913	14702	17914	21591	25738	30407
			38	6560	8529	10763	13331	16257	19591	23355	27568
			43	5487	7551	9833	12213	14908	17954	21388	25241
		50Hz	30	13616	17275	21548	26416	31817	38018	44682	52181
			32	13118	16719	20851	25548	30846	36767	43319	50501
			38	11551	14969	18775	23062	27888	33202	39070	45507
			43	9554	13148	17123	21094	25461	30356	35707	41512
		60Hz	30	15860	20088	24952	30394	36384	43177	50366	66029
			32	15383	19589	24364	29754	35747	42378	49703	56405
			38	13536	17496	21919	26818	32251	38286	44269	-
			43	11140	15331	19965	24465	29467	34905	-	-

ACPAC APS semi-hermetic.

Capacities - R452A

(30/60 Hz values apply only when an optional, field-installed VSD is used. Otherwise, refer to 50 Hz values)

Product Code	Model Number	Frequency	Ambient Temperature: °C	Capacity: Watts								
				Evaporating Temperature: °C								
				R452A								
				-30	-25	-20	-15	-10	-5	0	5	
3508161	APS46.5ML2-IV	30Hz	30	9290	12139	15625	19818	24830	30576	37228	44848	
			32	8922	11673	15067	19179	24007	29578	36121	43524	
			38	7793	10327	13434	17152	21531	26662	32652	39445	
		43	6634	9124	12117	15563	19581	24367	29801	36049		
		50Hz	30	15911	20549	26100	32595	40049	48473	57860	68204	
			32	15254	19762	25147	31444	38673	46842	55955	65999	
	38		13292	17418	22320	28037	34597	42018	50312	59481		
	60Hz	30	18414	23662	29881	37020	45233	54161	-	-		
		32	17663	22736	28726	35694	43599	52253	-	-		
		38	15350	20008	25510	31775	38852	46735	-	-		
	3508162	APS56.4ML2-IV	30Hz	30	10631	13685	17335	21595	26483	32000	38145	44913
				32	10212	13180	16724	20861	25601	30955	36929	43512
38				8976	11686	14914	18678	22995	27878	33330	39359	
43			7659	10288	13481	16937	20903	25395	30422	35449		
50Hz			30	19530	25126	31812	39617	48564	58663	69918	82320	
			32	18759	24199	30688	38264	46949	56758	67693	79754	
		38	16488	21456	27366	34260	42167	51106	61094	72135		
60Hz		30	23094	29727	37654	46910	57527	69511	82859	97563		
		32	22182	28629	36327	45313	55608	67241	80217	94517		
		38	19500	25386	32397	40574	49951	60557	72401	-		
3508163		APS64.2ML2-IV	30Hz	30	13223	17097	21590	26758	32714	39460	47069	55585
				32	12703	16502	20866	25903	31630	38187	45539	53762
	38			11081	14642	18699	23298	28533	34473	41163	48589	
	43		9320	12939	17010	21310	26135	31667	37805	44705		
	50Hz		30	23733	30235	37797	46458	56231	67120	79111	92182	
			32	22796	29148	36509	44917	54392	64946	76567	89242	
		38	19922	25888	32701	40409	49053	58655	69222	80757		
	60Hz	30	27881	35413	44183	54105	65232	77543	90893	-		
		32	26779	34190	42637	52343	63077	74931	-	-		
		38	23385	30297	38183	47013	56842	67755	-	-		
	43	19037	26428	34742	43090	52173	-	-	-			

Additional compressor cooling required
Capacities based on EN13215 Midpoint ratings: Return Vapour 20°C, Subcooling 3K

Capacities - R134a

(30/60 Hz values apply only when an optional, field-installed VSD is used. Otherwise, refer to 50 Hz values)

Product Code	Model Number	Frequency	Ambient Temperature: °C	Capacity: Watts					
				Evaporating Temperature: °C					
				R134a					
				-15	-10	-5	0	5	10
2701982	APS4.6ML2-1	50Hz	30	1837	2341	2929	3610	4390	5275
			32	1784	2278	2855	3523	4289	5158
			38	1628	2094	2638	3267	3988	4808
			43	1503	1945	2461	3057	3740	4518
			30	2709	3438	4282	5247	6333	7544
			32	2632	3345	4171	5114	6177	7361
2701983	APS6.0ML2-1	50Hz	38	2402	3067	3838	4718	5710	6816
			43	2211	2837	3562	4390	5323	6365
			30	3547	4509	5649	6974	8490	10201
			32	3438	4379	5494	6790	8274	9948
			38	3115	3991	5029	6238	7623	9188
			43	2849	3670	4644	5779	7082	8556
2701984	APS8.3ML2-1	50Hz	30	5235	6616	8221	10068	12171	14539
			32	5084	6439	8014	9823	11882	14202
			38	4626	5907	7388	9086	11015	13189
			43	4242	5462	6864	8469	10290	12342
			30	5900	7558	9440	11573	13939	16546
			32	5700	7318	9163	11248	13546	16088
2701985	APSI1.7ML3-1	50Hz	38	5111	6624	8334	10271	12456	14812
			43	4646	6054	7675	9495	11520	13765
			30	6866	8757	10892	13278	15921	18766
			32	6627	8474	10581	12919	15490	18270
			38	5947	7671	9616	11781	14200	16823
			43	5405	7014	8844	10884	13136	15580
3508157	APSI4.4ML3-1V	30Hz	30	3420	4414	5570	6905	8429	10129
			32	3299	4272	5409	6712	8200	9877
			38	2960	3870	4927	6143	7536	9094
		50Hz	30	5900	7558	9440	11573	13939	16546
			32	5700	7318	9163	11248	13546	16088
			38	5111	6624	8334	10271	12456	14812
3508158	APSI9.0ML2-1V	30Hz	30	4550	5881	7457	9300	11464	13934
			32	4429	5732	7280	9086	11198	13635
			38	4051	5278	6734	8434	10411	12683
		50Hz	30	7465	9537	12005	14892	18224	22020
			32	7260	9291	11707	14535	17798	21516
			38	6644	8549	10810	13456	16510	19994
3508158	APSI9.0ML2-1V	60Hz	30	8852	11289	14171	17534	21415	25771
			32	8611	10991	13823	17119	20907	25192
			38	7885	10121	12768	15854	19406	23413
		43	7280	9380	11891	14785	18136	21895	

ACPAC APS semi-hermetic.

Capacities - R134a

(30/60 Hz values apply only when an optional, field-installed VSD is used. Otherwise, refer to 50 Hz values)

Product Code	Model Number	Frequency	Ambient Temperature: °C	Capacity: Watts					
				Evaporating Temperature: °C					
				R134a					
				-15	-10	-5	0	5	10
3508159	APS25.8ML2-IV	30Hz	30	6407	8232	10308	12685	15420	18501
			32	6205	7994	10029	12370	15055	18080
			38	5605	7286	9204	11416	13974	16844
			43	5101	6702	8540	10638	13064	15812
		50Hz	30	11465	14525	18071	22123	26700	31817
			32	11107	14110	17590	21569	26065	31094
			38	10047	12873	16153	19910	24163	28928
			43	9179	11855	14966	18535	22582	27125
		60Hz	30	13481	17037	21148	25834	31112	36944
			32	13061	16552	20589	25193	30381	36115
			38	11840	15109	18890	23238	28148	33545
			43	10784	13900	17514	21651	26295	31449
3508160	APS33.6ML2-IV	30Hz	30	8246	10372	12882	15819	19236	23168
			32	8032	10125	12586	15463	18833	22684
			38	7399	9381	11697	14410	17541	21180
			43	6859	8759	10950	13490	16475	19928
		50Hz	30	14581	18243	22513	27439	33063	39418
			32	14206	17803	21989	26816	32324	38547
			38	13077	16475	20410	24935	30093	35922
			43	12131	15361	19085	23357	28223	33723
		60Hz	30	17131	21387	26310	31959	38345	45510
			32	16692	20874	25701	31241	37497	44518
			38	15370	19298	23821	29029	34848	41419
			43	14242	18002	22289	27144	32672	38880
3508168	APS38.2ML2-IV	30Hz	30	9246	11667	14518	17863	21780	26316
			32	9009	11395	14189	17477	21327	25770
			38	8312	10568	13184	16291	19866	24056
			43	7716	9879	12369	15280	18690	22642
		50Hz	30	16513	20722	25638	31399	38024	45565
			32	16082	20228	25064	30692	37201	44617
			38	14844	18750	23266	28589	34618	41572
			43	13767	17499	21799	26757	32469	39065
		60Hz	30	19466	24373	30125	36777	44389	53120
			32	18959	23794	29434	35931	43468	51888
			38	17504	22034	27317	33445	40397	48324
			43	16216	20571	25542	31281	37869	45394

Product Code	Model Number	Frequency	Ambient Temperature: °C	Capacity: Watts					
				Evaporating Temperature: °C					
				R134a					
				-15	-10	-5	0	5	10
3508161	APS46.5ML2-IV	30Hz	30	11091	14287	18036	22343	27274	32870
			32	10722	13854	17499	21738	26557	32030
			38	9668	12590	15974	19925	24390	29501
			43	8840	11556	14744	18442	22658	27530
		50Hz	30	19504	24975	31289	38470	46535	55494
			32	18868	24213	30383	37403	45291	54058
			38	17016	21985	27725	34264	41623	49816
			43	15539	20198	25582	31722	38642	46358
		60Hz	30	22870	29177	36451	44655	53863	63941
			32	22130	28322	35379	43435	52405	62321
			38	19975	25697	32272	39783	48126	57355
			43	18225	23596	29817	36827	44684	53393
3508162	APS56.4ML2-IV	30Hz	30	12804	16327	20471	25276	30784	37077
			32	12447	15898	19955	24659	30075	36237
			38	11366	14618	18418	22837	27965	33745
			43	10468	13555	17162	21332	26168	31666
		50Hz	30	22530	28558	35539	43516	52523	62590
			32	21890	27796	34635	42449	51276	61143
			38	19974	25516	31928	39256	47540	56811
			43	18389	23626	29682	36606	44437	53212
		60Hz	30	26400	33383	41406	50567	60775	72107
			32	25654	32498	40361	49265	59261	70469
			38	23400	29779	37123	45536	54927	65375
			43	21518	27593	34542	42384	51264	61069
3508163	APS64.2ML2-IV	30Hz	30	15861	20015	24883	30446	36820	44099
			32	15444	19528	24312	29757	36017	43140
			38	14200	18054	22585	27642	33537	40231
			43	13159	16829	21124	25949	31463	37795
		50Hz	30	28657	35788	44082	53610	64426	76569
			32	27925	34925	43054	52383	62968	74849
			38	25718	32327	39960	48691	58582	69679
			43	23870	30152	37370	45603	54917	65361
		60Hz	30	28657	35788	44082	53610	64426	76569
			32	27925	34925	43054	52383	62968	74849
			38	25718	32327	39960	48691	58582	69679
			43	23870	30152	37370	45603	54917	65361

Additional compressor cooling required
Capacities based on EN13215 Midpoint ratings: Return Vapour 20°C, Subcooling 3K

ACPAC APS semi-hermetic.

Capacities - R513A

(30/60 Hz values apply only when an optional, field-installed VSD is used. Otherwise, refer to 50 Hz values)

Product Code	Model Number	Frequency	Ambient Temperature: °C	Capacity: Watts					
				Evaporating Temperature: °C					
				R513A					
				-15	-10	-5	0	5	10
2701982	APS4.6ML2-1	50Hz	30	2059	2607	3244	3980	4815	5749
			32	1995	2533	3158	3879	4697	5622
			38	1824	2331	2917	3597	4374	5252
			43	1695	2174	2734	3377	4117	4947
2701983	APS6.0ML2-1	50Hz	30	2914	3649	4497	5458	6533	7723
			32	2827	3545	4372	5310	6360	7523
			38	2567	3233	4001	4872	5847	6927
			43	2353	2978	3697	4513	5426	6439
2701984	APS8.3ML2-1	50Hz	30	3911	4923	6107	7493	9042	10776
			32	3788	4775	5936	7281	8813	10515
			38	3423	4338	5433	6696	8121	9724
			43	3123	3993	5012	6199	7565	9070
2701985	APSI1.7ML3-1	50Hz	30	5647	7048	8657	10485	12541	14833
			32	5480	6852	8425	10212	12222	14461
			38	4978	6262	7728	9391	11261	13345
			43	4559	5769	7146	8706	10458	12413
ACPAC VSD-Ready Case Units									
3508157	APSI4.4ML3-1V	30Hz	30	3662	4674	5843	7181	8698	10374
			32	3529	4517	5665	6968	8443	10092
			38	3154	4072	5129	6334	7701	9215
			43	2854	3703	4694	5811	7089	8509
		50Hz	30	6318	8004	9903	12038	14384	16946
			32	6098	7739	9596	11676	13947	16437
			38	5445	6969	8677	10590	12729	15010
			43	4927	6336	7940	9720	11680	13830
		60Hz	30	7353	9274	11426	13811	16429	19220
			32	7089	8962	11082	13412	15950	18668
			38	6336	8072	10011	12148	14511	17048
			43	5732	7339	9149	11142	13319	15655
30Hz	30	4911	6271	7847	9698	11849	14305		
	32	4773	6102	7647	9457	11553	13962		
	38	4343	5587	7025	8719	10675	12924		
	43	3988	5154	6518	8095	9940	12049		
50Hz	30	8013	10099	12576	15442	18747	22469		
	32	7780	9821	12242	15057	18277	21934		
	38	7074	8997	11254	13875	16878	20277		
	43	6520	8307	10410	12868	15706	18876		
60Hz	30	9480	11935	14819	18158	21981	26230		
	32	9207	11609	14429	17697	21422	25598		
	38	8392	10628	13259	16307	19784	23673		
	43	7717	9809	12299	15124	18416	22080		

Product Code	Model Number	Frequency	Ambient Temperature: °C	Capacity: Watts					
				Evaporating Temperature: °C					
				R513A					
				-15	-10	-5	0	5	10
3508159	APS25.8ML2-1V	30Hz	30	6940	8788	10884	13276	15999	19070
			32	6714	8521	10571	12922	15590	18602
			38	6029	7748	9654	11867	14369	17218
			43	5471	7095	8903	11006	13370	16085
		50Hz	30	12328	15421	18981	23018	27542	32559
			32	11926	14956	18444	22402	26840	31764
			38	10738	13576	16850	20571	24750	29395
			43	9770	12449	15543	19067	23031	27444
		60Hz	30	14457	18054	22186	26817	31987	37725
			32	13988	17513	21546	26086	31158	36820
			38	12600	15893	19682	23979	28703	34022
			43	11471	14584	18143	22215	26706	31724
3508160	APS33.6ML2-1V	30Hz	30	8859	11002	13520	16450	19841	23718
			32	8617	10723	13186	16050	19389	23180
			38	7912	9870	12173	14876	17959	21523
			43	7303	9177	11362	13883	16793	20160
		50Hz	30	15596	19256	23477	28327	33824	39986
			32	15172	18760	22907	27637	33058	39093
			38	13912	17263	21142	25568	30580	36249
			43	12855	16054	19692	23859	28569	33898
		60Hz	30	18278	22512	27373	32882	39139	46043
			32	17784	21936	26695	32091	38208	44967
			38	16312	20168	24639	29676	35339	41639
			43	15035	18743	22938	27647	33015	38950
3508168	APS38.2ML2-1V	30Hz	30	10301	12829	15883	19393	23528	28264
			32	9752	12121	14918	18168	21889	26100
			38	8957	11196	13816	16877	20324	24269
			43	8285	10429	12933	15784	19054	22745
		50Hz	30	18054	22340	27463	33181	39815	47217
			32	17580	21803	26787	32437	38879	46127
			38	16117	20174	24774	30129	36170	42854
			43	14975	18778	23164	28218	33877	40137
		60Hz	30	21142	26058	31923	38395	45607	53533
			32	20795	25840	31576	38071	45257	53244
			38	19142	23871	29370	35559	42492	50168
			43	17734	22271	27412	33221	39722	46791

ACPAC APS semi-hermetic.

Capacities - R513A

(30/60 Hz values apply only when an optional, field-installed VSD is used. Otherwise, refer to 50 Hz values)

Product Code	Model Number	Frequency	Ambient Temperature: °C	Capacity: Watts					
				Evaporating Temperature: °C					
				R513A					
				-15	-10	-5	0	5	10
3508161	APS46.5ML2-1V	30Hz	30	11858	15087	18854	23156	28052	33574
			32	11442	14598	18253	22480	27253	32642
			38	10253	13184	16554	20468	24862	29860
			43	9328	12035	15197	18840	22966	27705
		50Hz	30	20854	26372	32708	39868	47861	56683
			32	20135	25515	31692	38678	46479	55092
			38	18049	23022	28732	35199	42427	50423
			43	16398	21038	26370	32409	39167	46652
		60Hz	30	24453	30810	38104	46280	55399	65311
			32	23616	29845	36904	44917	53780	63513
			38	21188	26907	33446	40868	49056	58054
			43	19231	24577	30735	37624	45292	53731
3508162	APS56.4ML2-1V	30Hz	30	13776	17342	21510	26310	31774	37979
			32	13372	16857	20931	25622	30988	37051
			38	12153	15419	19216	23603	28657	34315
			43	11145	14239	17826	21947	26696	32057
		50Hz	30	24242	30334	37344	45298	54216	64113
			32	23518	29475	36330	44109	52833	62518
			38	21358	26918	33312	40571	48718	57773
			43	19581	24817	30833	37663	45336	53872
		60Hz	30	28404	35459	43509	52639	62733	73860
			32	27561	34460	42336	51191	61061	72053
			38	25022	31414	38731	47062	56288	66481
			43	22912	28983	35881	43609	52301	61827
3508163	APS64.2ML2-1	30Hz	30	16962	21129	25998	31540	37868	45071
			32	16485	20573	25348	30759	36958	43989
			38	15068	18903	23397	28384	34180	40737
			43	13892	17530	21768	26502	31885	38046
		50Hz	30	30648	37781	46058	55537	66259	78257
			32	29808	36795	44889	54147	64614	76323
			38	27289	33848	41397	50000	59706	70554
			43	25202	31409	38510	46574	55654	65796
		60Hz	30	30648	37781	46058	55537	66260	78257
			32	29808	36796	44888	54147	64614	76322
			38	27290	33847	41397	49999	59705	70555
			43	25201	31408	38511	46574	55655	65795

■ Additional compressor cooling required
 Capacities based on EN13215 Midpoint ratings: Return Vapour 20°C, Subcooling 3K

Dimensional Drawings

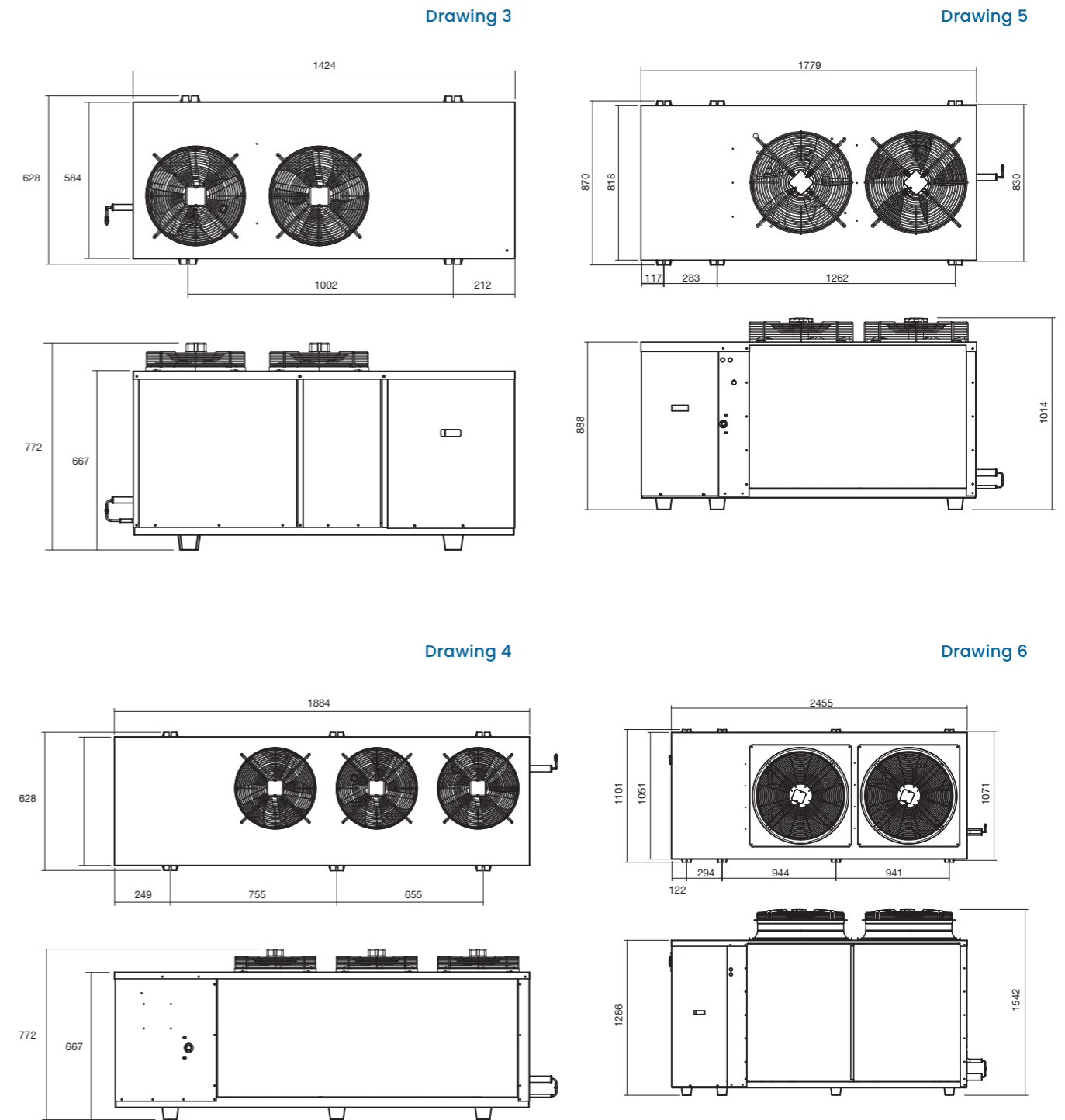

section three

ACPAC APS semi-hermetic.

(with VSD)

Semi-hermetic reciprocating with variable speed drive.



The variable speed drive (VSD) models of the APS semi-hermetic ACPAC range include a fully programmed vsd to adjust the compressor speed to maintain the desired evaporating pressure.

In extreme ambient temperatures the VSD models will take action to ensure the compressor pressures are maintained within the design operating envelope, this is called HLPS.

The APS VSD models are quick and easy to install and commission and are suitable for R134a, R404A and common compatible HFO/HFC refrigerant blends.

ACPAC APS VSD is well suited for refrigerated reach-in and walk-in coolrooms and freezers for every product imaginable including butcher shops, fish shops, fruit and vegetable stores, fast food chains, food processors and many more.

Standard features

- Variable Speed Drive (VSD) optimised for HVAC-R applications
- Controls system capacity to match load, reducing energy use and operating costs.
- Removable keypad that displays up to nine parameters on a single screen
- Pre-programmed to enable fast commissioning and trouble free operation
- High Limit Pressure Safety feature. The HLPS feature maintains operation within the compressor's operating envelope while maximising capacity in high ambient conditions.
- The VSD monitors and maintains the compressor within its maximum operating current
- Oil boost feature – during extended low-speed operation, the VSD periodically increases speed to boost refrigerant velocity and improve oil return.
- The EC fans on the larger APS units are controlled via an integrated 0-10V controller

ACPAC APS semi-hermetic (with VSD).

Medium / low temperature applications - R404A/R448A/R452A/R134a/R513A

Three phase

Product Code	Unit Model	Compressor						Fan(s)				Liquid Receiver Capacity kg @ 80%
		Tecumseh Model	Displ. m ³ /hr	Nominal HP	Motor Type	MOC Amps	Volts / Phase	No. Diam. Mm	MOC Amps	Air Flow m ³ /hr	Volts / Phase	
3508003	APS6.0ML2-2VSD	SH4536ZYZ	9.88	2	DOL	6.7	415/3	2 x 350	2 x 0.65	4210	240V/1	10
3508005	APS11.7ML3-2VSD	SH4567ZYZ	17.93	4	DOL	12.5	415/3	3 x 350	3 x 0.65	6315	240V/1	10
3508007	APS25.8ML2-1VSD	SH4615ZMZ	41.32	12	DOL	22.4	415/3	2 x 500	2 x 3.3	11530	240V/1	12
3508011	APS56.4ML2-1VSD	SH4632ZMZ	83.81	30	DOL	49.2	415/3	2 x 710	2 x 1.5	25060	415/3	25

Dimension properties

Product Code	Unit Model	Unit connections		Weight kg	Sound Power Level dBA	Dimensions			Drawing No.
		Suction	Liquid			L mm	W mm	H mm	
3508003	APS6.0ML2-2VSD	7/8"	1/2"	175	67	1420	630	820	7
3508005	APS11.7ML3-2VSD	1-1/8"	1/2"	205	70	1880	630	820	8
3508007	APS25.8ML2-1VSD	1-3/8"	5/8"	350	75	1779	870	1014	9
3508011	APS56.4ML2-1VSD	2-1/8"	1-1/8"	670	81	2455	1101	1542	10

Vacon VSD models

Vacon VSD Product code	Vacon Flow Drive Model	Vacon Frame Number	Dimensions (WxHxD)(mm)	Weight Kg
3425001	0100-3L-0009-5-FLOW+IP54	MR4	128 x 328 x 190	6
3425003	0100-3L-0016-5-FLOW+IP54	MR5	144 x 419 x 214	10
3425005	0100-3L-0031-5-FLOW+IP54	MR5	144 x 419 x 214	10
3425008	0100-3L-0061-5-FLOW+IP54	MR6	195 x 557 x 229	20

Capacities - R404A

Model Number	Frequency Hz	Ambient Temperature: °C	Capacity: Watts							
			Evaporating Temperature: °C							
			R404A							
			-30	-25	-20	-15	-10	-5	0	5
APS6.0ML2-2VSD	30	30	1402	1800	2265	2795	3394	4065	4793	5616
		32	1356	1742	2190	2696	3286	3937	4655	5441
		38	1219	1572	1977	2441	2966	3555	4207	4922
		43	1118	1435	1804	2227	2704	3242	3839	4497
	50	30	2306	2962	3725	4600	5588	6693	7915	9255
		32	2229	2865	3604	4450	5408	6480	7666	8967
		38	2008	2582	3249	4014	4880	5850	6928	8114
		43	1834	2358	2965	3661	4451	5337	6325	7414
	60	30	2776	3561	4479	5526	6709	8034	9471	11098
		32	2683	3445	4331	5330	6495	7781	9200	10755
		38	2411	3108	3909	4827	5868	7032	8323	-
		43	2212	2841	3570	4409	5356	6425	7610	-
APS11.7ML3-2VSD	30	30	2567	3251	4011	4894	5844	6934	8103	-
		32	2489	3154	3903	4746	5683	6699	7851	-
		38	2272	2870	3547	4305	5146	6067	7092	-
		43	2099	2644	3258	3944	4703	5543	6461	-
	50	30	4675	5909	7315	8899	10666	12617	14751	-
		32	4533	5732	7096	8630	10340	12227	14291	-
		38	4123	5214	6446	7827	9361	11053	12905	-
		43	3807	4803	5920	7167	8551	10076	11748	-
	60	30	5576	7062	8713	10631	12695	15061	17602	-
		32	5407	6852	8478	10310	12346	14552	17054	-
		38	4935	6235	7704	9351	11179	13198	15405	-
		43	4559	5744	7078	8567	10216	12040	-	-
APS25.8ML2-1VSD	30	30	5371	6940	8757	10831	13055	15644	18503	-
		32	5157	6679	8443	10363	12621	15139	17918	-
		38	4503	5907	7513	9262	11323	13628	16183	-
		43	4007	5276	6749	8356	10254	12384	1475	-
	50	30	9749	12608	15916	19690	23943	28684	33917	-
		32	9357	12133	15344	19010	23144	27756	32850	-
		38	8201	10725	13648	16989	20765	24988	29667	-
		43	7260	9574	12254	15324	18801	22700	27033	-
	60	30	11667	15074	19022	23526	28359	33982	40192	-
		32	11201	14509	1834	22510	27416	35886	38922	-
		38	9782	12832	16319	20119	24597	29602	35153	-
		43	8705	11461	14660	18151	22274	26901	-	-
APS56.4ML2-1VSD	30	30	11518	14771	18541	22848	27715	33151	39163	45752
		32	11093	14254	17914	22094	26814	32091	37936	44347
		38	9851	12727	16051	19849	24143	28951	34286	40160
		43	8850	11490	14530	18007	21941	26358	31271	-
	50	30	21158	27120	34024	41913	50822	60774	71783	83856
		32	20379	26170	32870	40527	49175	58840	69540	81285
		38	18093	23366	29453	36407	44270	53074	62845	73601
		43	16251	21087	26659	33024	40228	48311	57306	67237
	60	30	25020	32086	40274	49630	60203	72012	85070	99383
		32	24097	30963	38912	47993	58245	69708	82405	96331
		38	21399	27645	34867	43117	52443	62887	74476	-
		43	19225	24958	31562	39115	47660	57225	-	-

Additional compressor cooling required
Capacities based on EN13215 Midpoint ratings: Return Vapour 20°C, Subcooling 3K

ACPAC APS semi-hermetic (with VSD).

Capacities - R448A

Product Code	Model Number	Frequency Hz	Ambient Temperature: °C	Capacity: Watts								
				Evaporating Temperature: °C								
				R448A								
				-30	-25	-20	-15	-10	-5	0	5	
3508003	APS6.0ML2-2VSD	30	30	1276	1705	2217	2816	3515	4326	5259	6306	
			32	1227	1645	2143	2725	3408	4192	5097	6123	
			38	1079	1464	1914	2449	3068	3787	4615	5557	
			43	946	1305	1726	2209	2786	3444	4204	5075	
		50	30	2067	2748	3548	4475	5540	6749	8106	9616	
			32	1987	2650	3426	4326	5359	6532	7851	9319	
			38	1738	2347	3054	3873	4813	5882	7086	8430	
			43	1522	2087	2740	3492	4356	5339	6449	7691	
		60	30	2447	3252	4184	5252	6477	7842	9384	11058	
			32	2351	3130	4041	5073	6262	7596	9085	10705	
			38	2058	2773	3593	4544	5619	6838	8194	9696	
			43	1803	2460	3226	4089	5084	6196	7459	-	
3508005	APS11.7ML3-2VSD	30	30	2409	3121	3958	4948	6112	7447	9000	10736	
			32	2322	3017	3840	4805	5939	7240	8747	10435	
			38	2079	2716	3471	4361	5404	6625	8026	9604	
			43	1875	2473	3168	4001	4962	6126	7424	8893	
		50	30	4308	5561	7028	8734	10706	12964	15526	18406	
			32	4159	5379	6807	8470	10393	12597	15102	17921	
			38	3716	4838	6152	7685	9463	11510	13844	16482	
			43	3352	4395	5615	7041	8701	10617	12811	15300	
		60	30	5091	6559	8264	10238	12514	15113	18049	21356	
			32	4910	6346	8007	9946	12168	14694	17552	20776	
			38	4391	5700	7237	9009	11067	13419	16089	19113	
			43	3958	5183	6614	8253	10153	12377	14873	17710	
3508007	APS25.8ML2-1VSD	30	30	5361	6708	8266	10397	12765	15601	18858	22115	
			32	5180	6764	8019	9995	12396	15145	18323	21501	
			38	4641	5636	7262	9072	11299	13853	16817	19781	
			43	4198	5123	6628	8351	10404	12797	15570	18343	
		50	30	9495	12383	15788	19783	24432	29789	35899	42796	
			32	9145	11953	15263	19148	23674	28897	34862	41606	
			38	8113	10689	13719	17280	21442	26265	31799	38085	
			43	7269	9658	12461	15758	19623	24117	29297	35207	
		60	30	11646	14570	18295	22999	28268	34608	41832	49056	
			32	11252	14693	17737	22125	27483	33750	40755	47660	
			38	10082	12472	16091	20176	25068	30842	36616	42390	
			43	9119	11325	14700	18549	23143	28531	33919	39307	
3508011	APS56.4ML2-1VSD	30	30	11566	14944	18878	22631	28682	34645	41366	48789	
			32	11208	14504	18342	22789	27894	33714	40277	47534	
			38	10090	13176	16710	20809	25520	30900	36987	43735	
			43	9215	12056	15337	19142	23519	28531	34217	40522	
		50	30	20507	26517	33515	41613	50900	61453	73330	86571	
			32	19814	25671	32482	40359	49395	59669	71241	84154	
			38	17727	23120	29365	36577	44859	54293	64950	76882	
			43	15992	20992	26759	33414	41064	49798	59694	70810	
		60	30	25124	32461	41007	49160	62303	75256	89856	105979	
			32	24345	31506	39842	49503	60592	73235	87491	103253	
			38	21917	28620	36297	45201	55434	67121	80343	95001	
			43	20016	26189	33316	41580	51088	61975	74326	-	

Additional compressor cooling required
Capacities based on EN13215 Midpoint ratings: Return Vapour 20°C, Subcooling 3K

Capacities - R452A

Product Code	Model Number	Frequency Hz	Ambient Temperature: °C	Capacity: Watts								
				Evaporating Temperature: °C								
				R452A								
				-30	-25	-20	-15	-10	-5	0	5	
3508003	APS6.0ML2-2VSD	30	30	1356	1755	2244	2819	3491	4261	5128	6107	
			32	1306	1696	2167	2725	3371	4119	4963	5905	
			38	1167	1515	1936	2438	3022	3697	4460	5317	
			43	1054	1368	1757	2211	2739	3355	4055	4837	
		50	30	2184	2814	3567	4444	5446	6574	7825	9197	
			32	2106	2715	3442	4290	5259	6351	7564	8896	
			38	1877	2424	3076	3839	4713	5700	6801	8013	
			43	1694	2192	2786	3480	4278	5180	6190	7305	
		60	30	2585	3318	4195	5204	6341	7623	9000	10549	
			32	2490	3203	4044	5014	6123	7355	8714	10195	
			38	2222	2860	3612	4489	5485	6613	7844	-	
			43	2008	2588	3277	4078	4984	6014	-	-	
3508005	APS11.7ML3-2VSD	30	30	2413	3080	3873	4799	5869	7080	8446	9812	
			32	2338	2981	3757	4650	5692	6865	8185	9505	
			38	2105	2702	3394	4209	5144	6209	7401	8593	
			43	1934	2481	3121	3854	4706	5659	6739	7819	
		50	30	4311	5473	6838	8410	10190	12177	14366	16555	
			32	4168	5298	6623	8146	9869	11791	13908	16025	
			38	3760	4791	5990	7363	8912	10639	12542	14445	
			43	3460	4405	5498	6742	8145	9705	11427	13149	
		60	30	5085	6442	8029	9834	11866	14116	16577	19038	
			32	4918	6230	7778	9517	11498	13678	16040	18402	
			38	4432	5637	7023	8601	10371	12332	14443	16554	
			43	4081	5195	6456	7870	9481	11244	-	-	
3508007	APS25.8ML2-1VSD	30	30	4958	6429	8188	10238	12475	15101	18022	20943	
			32	4748	6176	7882	9785	12050	14604	17443	20282	
			38	4100	5421	6980	8715	10787	13123	15733	18343	
			43	3380	4672	6257	7858	9769	11932	14349	16766	
		50	30	9001	11681	14881	18612	22880	27689	33035	38381	
			32	8616	11219	14326	17949	22098	26774	31979	37184	
			38	7469	9844	12679	15988	19781	24065	28843	33621	
			43	6137	8482	11361	14411	17912	21873	26299	30725	
		60	30	10773	13966	17786	22238	27100	32803	39147	45491	
			32	10314	13416	17123	21255	26177	31618	37890	44162	
			38	8908	11778	15161	18934	23432	28508	34176	39844	
			43	7341	10148	13591	17070	21221	25921	-	-	
3508011	APS56.4ML2-1VSD	30	30	10631	13685	17335	21595	26483	32000	38145	44913	
			32	10212	13180	16724	20861	25601	30955	36929	43512	
			38	8976	11686	14914	18678	22995	27878	33330	39359	
			43	7659	10288	13481	16937	20903	25395	30422	35449	
		50	30	19530	25126	31812	39617	48564	58663	69918	82320	
			32	18759	24199	30688	38264	46949	56758	67693	79754	
			38	16488	21456	27366	34260	42167	51106	61094	72135	
			43	14054	18877	24733	31063	38325	46547	55750	65946	
		60	30	23094	29727	37654	46910	57527	69511	82859	97563	
			32	22182	28629	36327	45313	55608	67241	80217	94517	
			38	19500	25386	32397	40574	49951	60557	72401	-	
			43	16639	22348	29282	36792	45405	55135	-	-	

Additional compressor cooling required
Capacities based on EN13215 Midpoint ratings: Return Vapour 20°C, Subcooling 3K

ACPAC APS semi-hermetic (with VSD).

Capacities - R134a

Product Code	Model Number	Frequency Hz	Ambient Temperature: °C	Capacity: Watts							
				Evaporating Temperature: °C							
				R134a							
				-30	-25	-20	-15	-10	-5	0	5
3508003	APS6.0ML2-2VSD	30	30	1679	2144	2685	3313	4031	4839	5128	6107
			32	1632	2087	2617	3233	3934	4723	4963	5905
			38	1488	1920	2414	2982	3635	4378	4460	5317
			43	1368	1774	2243	2779	3393	4090	4055	4837
		50	30	2709	3438	4282	5247	6333	7544	7825	9197
			32	2632	3345	4171	5114	6177	7361	7564	8896
			38	2402	3067	3838	4718	5710	6816	6801	8013
			43	2211	2837	3562	4390	5323	6365	6190	7305
		60	30	3203	4054	5035	6150	7402	8781	9000	10549
			32	3112	3942	4907	5995	7224	8560	8714	10195
			38	2841	3619	4511	5524	6670	7932	7844	-
			43	2617	3347	4193	5149	6222	7403	-	-
3508005	APS11.7ML3-2VSD	30	30	2906	3719	4663	5746	6989	8419	8446	9812
			32	2822	3620	4548	5603	6825	8219	8185	9505
			38	2562	3316	4194	5188	6334	7638	7401	8593
			43	2348	3065	3899	4836	5922	7160	6739	7819
		50	30	5235	6616	8221	10068	12171	14539	14366	16555
			32	5084	6439	8014	9823	11882	14202	13908	16025
			38	4626	5907	7388	9086	11015	13189	12542	14445
			43	4242	5462	6864	8469	10290	12342	11427	13149
		60	30	6166	7782	9646	11791	14208	16925	16577	19038
			32	5989	7574	9411	11498	13863	16526	16040	18402
			38	5436	6950	8660	10642	12851	15349	14443	16554
			43	5003	6419	8061	9910	11998	14338	-	-
3508007	APS25.8ML2-1VSD	30	30	6407	8232	10308	12685	15420	18501	18022	20943
			32	6205	7994	10029	12370	15055	18080	17443	20282
			38	5605	7286	9204	11416	13974	16844	15733	18343
			43	5101	6702	8540	10638	13064	15812	14349	16766
		50	30	11465	14525	18071	22123	26700	31817	33035	38381
			32	11107	14110	17590	21569	26065	31094	31979	37184
			38	10047	12873	16153	19910	24163	28928	28843	33621
			43	9179	11855	14966	18535	22582	27125	26299	30725
		60	30	13481	17037	21148	25834	31112	36944	39147	45491
			32	13061	16552	20589	25193	30381	36115	37890	41162
			38	11840	15109	18890	23238	28148	33545	34176	39844
			43	10784	13900	17514	21651	26295	31449	-	-
3508011	APS56.4ML2-1VSD	30	30	12804	16327	20471	25276	30784	37077	38145	44913
			32	12447	15898	19955	24659	30075	36237	36929	43512
			38	11366	14618	18418	22837	27965	33745	33330	39359
			43	10468	13555	17162	21332	26168	31666	30422	35449
		50	30	22530	28558	35539	43516	52523	62590	69918	82320
			32	21890	27796	34635	42449	51276	61143	67693	79754
			38	19974	25516	31928	39256	47540	56811	61094	72135
			43	18389	23626	29682	36606	44437	53212	55750	65946
		60	30	26400	33383	41406	50567	60775	72107	82859	97563
			32	25654	32498	40361	49265	59261	70469	80217	94517
			38	23400	29779	37123	45536	54927	65375	72401	-
			43	21518	27593	34542	42384	51264	61069	-	-

Additional compressor cooling required
Capacities based on EN13215 Midpoint ratings: Return Vapour 20°C, Subcooling 3K

Capacities - R513A

Product Code	Model Number	Frequency Hz	Ambient Temperature: °C	Capacity: Watts							
				Evaporating Temperature: °C							
				R513A							
				-30	-25	-20	-15	-10	-5	0	5
3508003	APS6.0ML2-2VSD	30	30	1814	2286	2835	3465	4184	4981	5128	6107
			32	1763	2221	2757	3373	4075	4860	4963	5905
			38	1602	2030	2526	3102	3753	4481	4460	5317
			43	1467	1870	2336	2869	3474	4165	4055	4837
		50	30	2914	3649	4497	5458	6533	7723	7825	9197
			32	2827	3545	4372	5310	6360	7523	7564	8896
			38	2567	3233	4001	4872	5847	6927	6801	8013
			43	2353	2978	3697	4513	5426	6439	6190	7305
		60	30	3436	4295	5273	6376	7608	8954	9000	10549
			32	3334	4171	5127	6206	7411	8728	8714	10195
			38	3028	3810	4689	5697	6818	8045	7844	-
			43	2779	3504	4340	5279	6314	7465	-	-
3508005	APS11.7ML3-2VSD	30	30	3154	3989	4929	6010	7245	8643	8446	9812
			32	3060	3877	4797	5856	7063	8422	8185	9505
			38	2775	3542	4405	5388	6512	7768	7401	8593
			43	2540	3260	4081	4995	6055	7252	6739	7819
		50	30	5647	7048	8657	10485	12541	14833	14366	16555
			32	5480	6852	8425	10212	12222	14461	13908	16025
			38	4978	6262	7728	9391	11261	13345	12542	14445
			43	4559	5769	7146	8706	10458	12413	11427	13149
		60	30	6639	8270	10140	12246	14603	17203	16577	19038
			32	6448	8041	9860	11927	14223	16764	16040	18402
			38	5848	7351	9049	10966	13092	15448	14443	16554
			43	5367	6764	8370	10156	12151	14382	-	-
3508007	APS25.8ML2-1VSD	30	30	6940	8788	10884	13276	15999	19070	18022	20943
			32	6714	8521	10571	12922	15590	18602	17443	20282
			38	6029	7748	9654	11867	14369	17218	15733	18343
			43	5471	7095	8903	11006	13370	16085	14349	16766
		50	30	12328	15421	18981	23018	27542	32559	33035	38381
			32	11926	14956	18444	22402	26840	31764	31979	37184
			38	10738	13576	16850	20571	24750	29395	28843	33621
			43	9770	12449	15543	19067	23031	27444	26299	30725
		60	30	14457	18054	22186	26817	31987	37725	39147	45491
			32	13988	17513	21546	26086	31158	36820	37890	41162
			38	12600	15893	19682	23979	28703	34022	34176	39844
			43	11471	14584	18143	22215	26706	31724	-	-
3508011	APS56.4ML2-1VSD	30	30	13776	17342	21510	26310	31774	37979	38145	44913
			32	13372	16857	20931	25622	30988	37051	36929	43512
			38	12153	15419	19216	23603	28657	34315	33330	39359
			43	11145	14239	17826	21947	26696	32057	30422	35449
		50	30	24242	30334	37344	45298	54216	64113	69918	82320
			32	23518	29475	36330	44109	52833	62518	67693	79754
			38	21358	26918	33312	40571	48718	57773	61094	72135
			43	19581	24817	30833	37663	45336	53872	55750	65946
		60	30	28404	35459	43509	52639	62733	73860	82859	97563
			32	27561	34460	42336	51191	61061	72053	80217	94517
			38	25022	31414	38731	47062	56288	66481	72401	-
			43	22912	28983	35881	43609	52301	61827	-	-

Capacities based on EN13215 Midpoint ratings: Return Vapour 20°C, Subcooling 3K

ACPAC APS semi-hermetic (with VSD).

Dimensional Drawings

Drawing 7

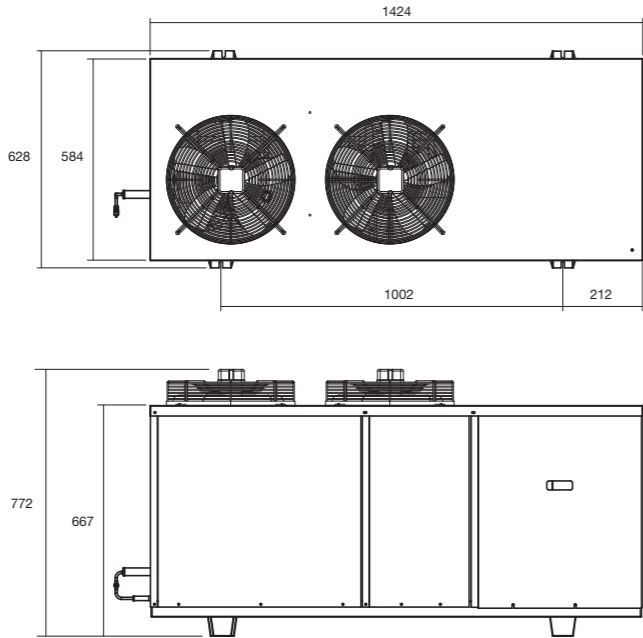

Drawing 9

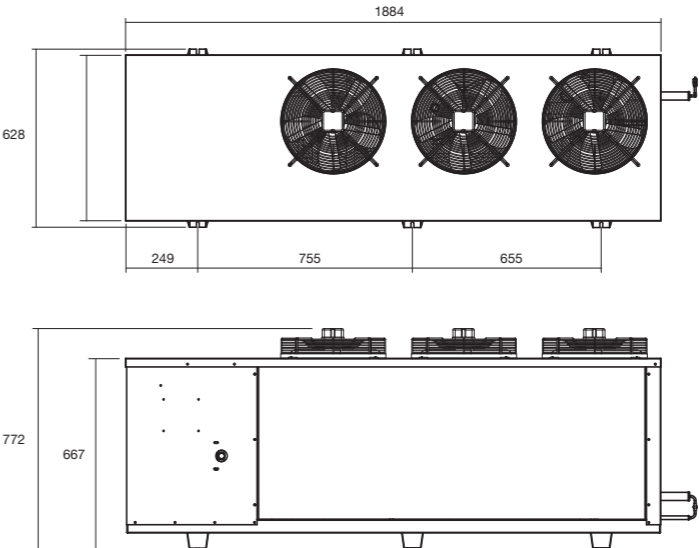

Drawing 8

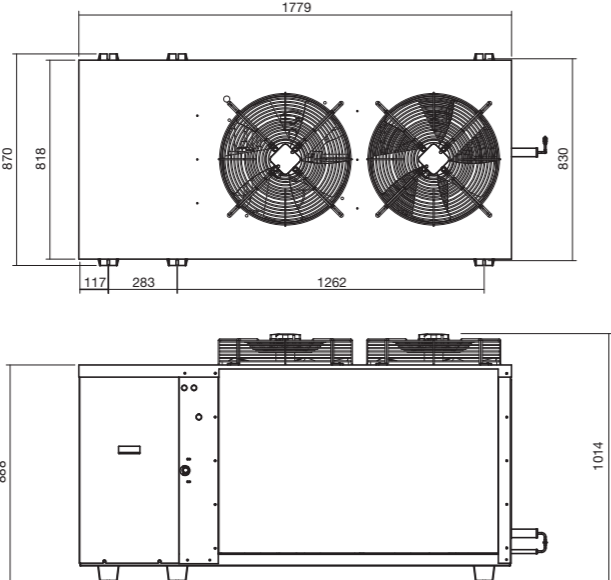

Drawing 10

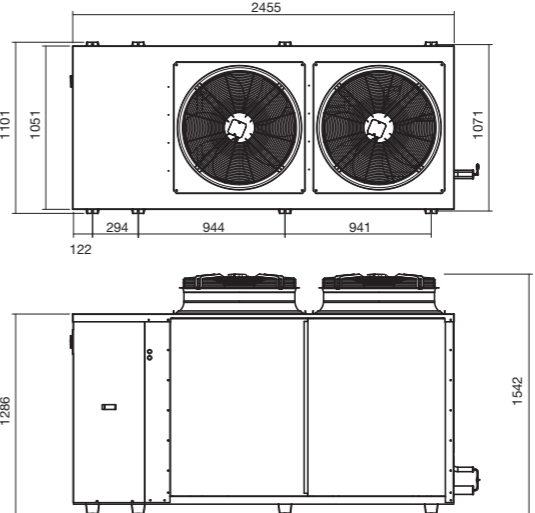

section four

A2L ACPAC hermetic.

ACPAC A2L Hermetic.



The complete refrigeration solution

The Tecumseh A2L ACPAC range is designed in Australia to provide a robust energy efficient, fully fitted packaged range with Tecumseh's world leading hermetically sealed A2L reciprocating compressors.

A2L ACPAC uses premium Tecumseh A2L compressors and large A2L optimised to ensure reliable refrigeration when you need it most.

Applications are diverse and include commercial food, beverage cooling, and freezing in supermarkets, as well as refrigeration applications in convenience stores, pubs and clubs, restaurants, cafés, food processors and many more.

Installation is quick and easy as every A2L ACPAC is fully fitted straight out of the box, and requires no further skills to use with A2L.

All A2L ACPAC units include condenser fan controls and epoxy coated condenser fins to ensure superb energy efficient performance in Australia and New Zealand's diverse weather conditions.

A2L ACPAC packaged condensing units are a perfect solution for your customers' refrigeration requirements, working towards a cleaner future.

Sustainable <150GWP solution. Approved for R455A & R454C.

Rigorously and Independently tested to stringent international electrical standards for compliance, safety and performance.

Larger electrical box for easier maintenance and servicing. A2L approved electrical components are enclosed within a robust and spacious enclosure.

Standard features

- World leading compressors.
- Large epoxy finned condenser/s.
- Liquid Receiver.
- Comprehensive electrical board fully wired to all electrical components.
- Multiple safety controls offering substantial protection.
- Carel fan speed controller provides stable condenser fan operation in diverse ambient conditions.
- Copper tails for easy connections.
- Galvanised powder coated enclosures not only protect the unit but provide a good looking professional finish.
- Easy to read wiring diagram is conveniently attached to inside panel for quicker servicing.
- Separate compressor and fan compartments for safe and easy maintenance.
- Easy access to all serviceable components.
- Fitted with EC Fans as standard.

ACPAC A2L Hermetic.

Medium temperature

Product Code	Unit Model	Compressor						Fan(s)				Liquid Receiver Capacity kg @ 80%
		Tecumseh Model	Displ. cm ³ /rev	Nominal HP	Motor Type	MOC Amps	Volts / Phase	No. Diam. Mm	MOC Amps	Air Flow m ³ /hr	Volts / Phase	
3508097	AP1.7M1-P-FZ	AJ4480P-FZ	24.20	1.1	CSR	6.94	220 - 240V 1PH	350	1.2	3600	230V 1PH	2.35
3508148	AP2.8M1-P-FZ	AJ4517P-FZ	25.95	1.4	CSR	7.62	220 - 240V 1PH	350	1.2	3600	230V 1PH	2.35
3508149	AP4.1M1-P-XC	FH4524P-XC	43.30	2.0	CSR	10.30	220 - 240V 1PH	350	1.2	3600	230V 1PH	2.35
3508098	AP5.7M2-P-XG	FH4532P-XG	50.60	2.6	TRI	4.33	380 - 420V 3PH	350 x 2	2.4	3600 x 2	230V 1PH	3.9
3508151	AP7.8M2-P-XG	FH4538P-XG	63.00	3.3	TRI	5.73	380 - 420V 3PH	350 x 2	2.4	3600 x 2	230V 1PH	3.9
3508155	AP8.8M2-P-TZ	AG4553P-TZ	100.70	4.4	TRI	7.72	400V 3PH	350 x 2	2.4	3600 x 2	230V 1PH	3.9
3508156	AP13.1M2-P-TZ	AG4573P-TZ	134.80	6.1	TRI	11.30	400V 3PH	350 x 2	2.4	3600 x 2	230V 1PH	3.9

Product Code	Unit Model	Unit connections		Weight kg	Sound Power Level dBA	Dimensions			Drawing No.
		Suction	Liquid			L mm	W mm	H mm	
3508097	AP1.7M1-P-FZ	5/8" (15.9)	3/8" (9.52)	71	65	1070	480	758	11
3508148	AP2.8M1-P-FZ	5/8" (15.9)	3/8" (9.52)	71	65	1070	480	758	11
3508149	AP4.1M1-P-XC	5/8" (15.9)	3/8" (9.52)	81	65	1070	480	758	11
3508098	AP5.7M2-P-XG	5/8" (15.9)	3/8" (9.52)	105	65	1284	628	772	12
3508151	AP7.8M2-P-XG	5/8" (15.9)	3/8" (9.52)	118	65	1284	628	772	12
3508155	AP8.8M2-P-TZ	7/8" (22.2)	1/2" (12.7)	146	65	1284	628	772	12
3508156	AP13.1M2-P-TZ	7/8" (22.2)	1/2" (12.7)	150	65	1284	628	772	12

R455A Medium / High Temperature application

Product Code	Model	Ambient Temperature: °C	Saturated Suction Temperature: °C						
			-15	-10	-5	0	5	10	15
3508097	AP1.7M1-P-FZ	32	1172	1481	1765	2122	2483	2858	3236
		35	1104	1377	1679	2003	2347	2740	3108
		38	1028	1289	1575	1905	2240	2586	2932
		43	911	1154	1420	1729	2041	2364	2687
3508148	AP2.8M1-P-FZ	32	1861	2313	2801	3364	3882	4370	4958
		35	1734	2158	2658	3144	3624	4188	4614
		38	1629	2034	2475	2986	3453	3891	4432
		43	1446	1814	2214	2690	3117	3515	3861
3508149	AP4.1M1-P-XC	32	2891	3718	4584	5519	6636	7696	8776
		35	2705	3457	4275	5242	6197	7186	8427
		38	2483	3243	4028	4872	5893	6855	7827
		43	2150	2856	3579	4351	5163	6189	7092
3508098	AP5.7M2-P-XG	32	3916	4855	5838	6968	7944	8843	9921
		35	3563	4470	5521	6478	7550	8472	9239
		38	3301	4182	5092	6146	7008	7866	8868
		43	2827	3651	4662	5502	6306	7105	7956
3508151	AP7.8M2-P-XG	32	5859	6898	8081	9358	10868	12196	13434
		35	5410	6406	7667	8907	10182	11430	12896
		38	5073	6031	7125	8303	9704	10920	12037
		43	4351	5349	6371	7468	8585	9912	10935
3508155	AP8.8M2-P-TZ	32	5649	7077	8680	10588	12302	14309	15756
		35	5166	6522	8214	9853	11778	13336	14644
		38	4789	6101	7579	9355	10933	12806	14114
		43	4005	5322	6702	8376	9850	11178	12396
3508156	AP13.1M2-P-TZ	32	9102	10753	12935	14955	17449	19356	20911
		35	8294	10134	11955	14256	16192	17923	20185
		38	7726	9269	11311	13169	14957	17196	18990
		43	6653	8115	9741	11799	13453	15592	17018

ACPAC A2L Hermetic.

R454C Medium / High Temperature application

Product Code	Model	Ambient Temperature: °C	Saturated Suction Temperature: °C						
			-15	-10	-5	0	5	10	15
3508097	AP1.7M1-P-FZ	32	1013	1284	1535	1850	2170	2501	2836
		35	957	1198	1462	1749	2053	2399	2726
		38	894	1123	1375	1665	1961	2266	2573
		43	797	1010	1245	1517	1791	2075	2359
3508148	AP2.8M1-P-FZ	32	1646	2043	2471	2963	3414	3838	4350
		35	1542	1917	2358	2785	3205	3697	4068
		38	1455	1817	2207	2659	3069	3452	3927
		43	1299	1632	1990	2415	2792	3143	3446
3508149	AP4.1M1-P-XC	32	2602	3361	4152	5004	6016	6976	7950
		35	2436	3127	3875	4756	5623	6518	7639
		38	2236	2936	3655	4425	5353	6223	7101
		43	1939	2591	3255	3962	4701	5631	6445
3508098	AP5.7M2-P-XG	32	3512	4386	5286	6313	7198	8010	8981
		35	3206	4040	5002	5875	6847	7680	8370
		38	2971	3783	4618	5579	6362	7138	8040
		43	2546	3310	4240	5008	5740	6462	7228
3508151	AP7.8M2-P-XG	32	5274	6232	7314	8476	9844	11045	12159
		35	4871	5791	6945	8075	9232	10359	11682
		38	4570	5457	6462	7538	8810	9908	10915
		43	3929	4855	5796	6800	7815	9016	9937
3508155	AP8.8M2-P-TZ	32	5164	6432	7855	9556	11084	12884	14188
		35	4749	5947	7442	8886	10588	11964	13125
		38	4434	5591	6887	8445	9819	11461	12604
		43	3768	4941	6146	7601	8862	9993	11028
3508156	AP13.1M2-P-TZ	32	8064	9598	11627	13531	15878	17705	19217
		35	7352	9049	10749	12899	14735	16394	18549
		38	6855	8281	10174	11919	13614	15732	17452
		43	5915	7260	8771	10688	12252	14272	15647

Capacities based on EN13215 Dewpoint ratings: Return Vapour 20°C, Subcooling 3K

Dimensional Drawings

Drawing 11

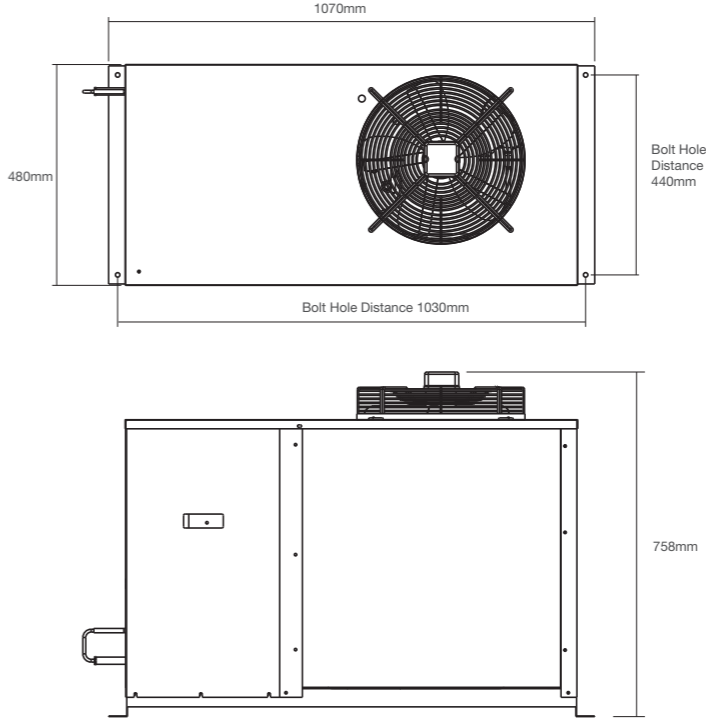

Drawing 12

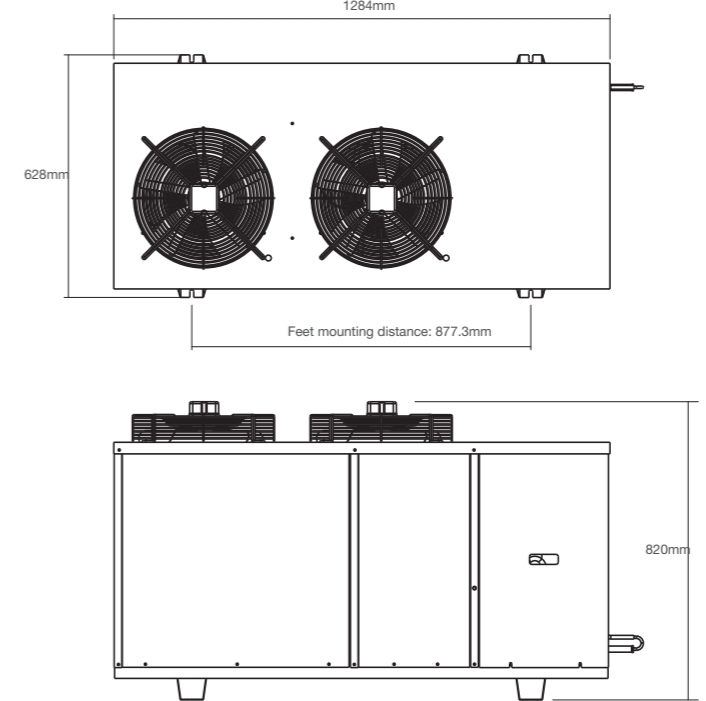

COMPAC range.

UNDERSTANDING THE COMPAC MODELS

The COMPAC part numbers are based around a nomenclature system, which means there's a thought behind the names, making it easy to decipher the model and its attributes.

Please see an example below of an COMPAC model number broken down.

COMPAC Nomenclature

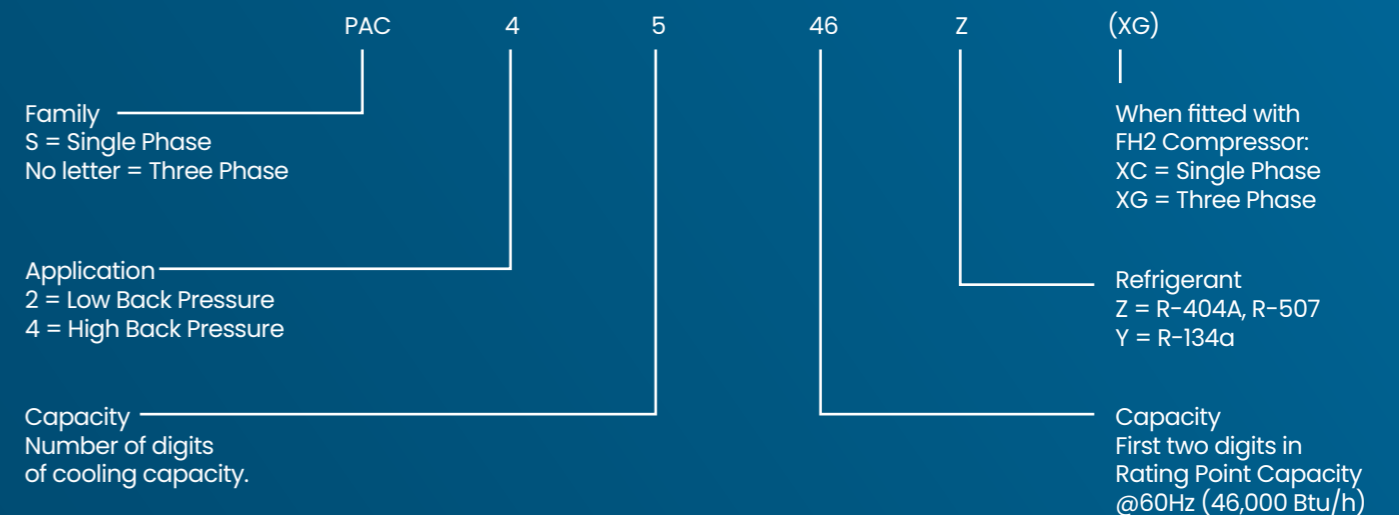

section five

COMPAC hermetic.

COMPAC hermetic.



Hermetically sealed reciprocating compressors.

The COMPAC is a range of fully fitted packaged units with world leading Tecumseh hermetically sealed reciprocating compressors. Designed with space constraints in mind, the horizontal discharge condenser configuration suits unit placement in car parks, roofs, on the side of buildings and mounted above one another without restricting airflow.

Installation is quick and easy, as every COMPAC is optioned straight out of the box. Once installed, you can relax knowing the premium compressors and large condensers will deliver reliable refrigeration when you need it most. Every COMPAC is built with high quality, corrosion resistant components, and extensive testing is completed on each unit, to ensure long life in the field.

Standard features

- Compactness. Housing is designed to optimise spacing and functionality
- Housing has a maximum length of 913mm for all models
- Powder coated steel casing
- Light in weight
- Easily serviceable as the mechanical and electrical components are in the same compartment
- Fan cycle control
- Factory leak tested
- World leading compressors
- Large epoxy finned curved condenser
- Oil separator on every model
- Suction accumulator on low temperature models
- Comprehensive electrical board fully wired to all electrical components
- Separate compressor and fan compartment for safe and easy maintenance
- Safety controls offering substantial protection

COMPAC Hermetic.

Medium temperature applications - R404A/R448A/R452A

Single phase

Product Code	Unit Model	Compressor					Fan(s)				Liquid Receiver Capacity kg @ 80%
		Tecumseh Model	Displ. cm ³ /rev	Nominal HP	MOC Amps	Volts / Phase	No. Diam. Mm	MOC Amps	Air Flow m ³ /hr	Volts / Phase	
3508016	PACS4517Z-EVO	CAJ4517Z	25.9	1.50	12.7	240/1	1 x 450	1.15	5050	240/1	3.9
3508018	PACS4519Z-EVO	CAJ4519Z	34.5	1.60	15.6	240/1	1 x 450	1.15	5050	240/1	3.9
3508132	PACS44524Z-EVO-XC	FH4524Z-XC	43.5	2.00	18.1	240/1	1 x 450	1.15	5050	240/1	3.9
3508134	PACS4532Z-EVO-XC	FH4532Z-XC	56.6	2.60	22.4	240/1	1 x 450	1.15	5050	240/1	3.9
3508136	PAC4538Z-EVO-XC	FH4540Z	74.2	3.30	27.0	240/1	1 x 500	1.75	6720	240/1	3.9

Three phase

Product Code	Unit Model	Compressor					Fan(s)				Liquid Receiver Capacity kg @ 80%
		Tecumseh Model	Displ. cm ³ /rev	Nominal HP	MOC Amps	Volts / Phase	No. Diam. Mm	MOC Amps	Air Flow m ³ /hr	Volts / Phase	
3508017	PAC4517Z-EVO	TAJ4517Z	25.9	1.50	4.4	415/3	1 x 450	1.15	5050	240/1	3.9
3508019	PAC4519Z-EVO	TAJ4519Z	34.5	1.60	6.2	415/3	1 x 450	1.15	5050	240/1	3.9
3508133	PAC4524Z-EVO-XG	FH4524Z-XG	43.5	2.00	7.7	415/3	1 x 450	1.15	5050	240/1	3.9
3508135	PAC4532Z-EVO-XG	FH4532Z-XG	56.6	2.60	9.0	415/3	1 x 450	1.15	5050	240/1	3.9
3508137	PAC4538Z-EVO-XG	FH4538Z-XG	74.2	3.30	9.2	415/3	1 x 500	1.75	6720	240/1	3.9
3508026	PAC4546Z-EVO	TAG4546Z	90.2	3.80	12.1	415/3	1 x 500	1.75	6720	240/1	3.9
3508027	PAC4553Z-EVO	TAG4553Z	100.7	4.40	14.0	415/3	2 x 450	2.30	10100	240/1	9.5
3508028	PAC4561Z-EVO	TAG4561Z	112.5	5.00	15.3	415/3	2 x 450	2.30	10100	240/1	9.5
3508029	PAC4568Z-EVO	TAG4568Z	124.4	5.70	17.8	415/3	2 x 450	2.30	10100	240/1	9.5
3508030	PAC4573Z-EVO	TAG4573Z	134.8	6.00	19.0	415/3	2 x 450	2.30	10100	240/1	9.5

Dimension properties

Product Code	Unit Model	Unit connections		Weight	Sound Power Level	Dimensions			Drawing No.
		Suction	Liquid			L mm	W mm	H mm	
3508016	PACS4517Z-EVO	5/8"	3/8"	69	65	913	416	633	13
3508017	PAC4517Z-EVO	5/8"	3/8"	67	65	913	416	633	13
3508018	PACS4519Z-EVO	5/8"	3/8"	69	68	913	416	633	13
3508019	PAC4519Z-EVO	5/8"	3/8"	67	68	913	416	633	13
3508132	PACS44524Z-EVO-XC	5/8"	3/8"	81	70	913	416	633	13
3508133	PAC4524Z-EVO-XG	5/8"	3/8"	77	70	913	416	633	13
3508134	PACS4532Z-EVO-XC	5/8"	3/8"	78	71	913	416	633	13
3508135	PAC4532Z-EVO-XG	5/8"	3/8"	78	71	913	416	633	13
3508136	PACS4538Z-EVO-XC	7/8"	1/2"	94	72	913	416	792	14
3508137	PAC4538Z-EVO-XG	7/8"	1/2"	91	72	913	416	792	14
3508026	PAC4546Z-EVO	7/8"	1/2"	102	73	913	416	792	14
3508027	PAC4553Z-EVO	7/8"	1/2"	125	75	913	416	1149	15
3508028	PAC4561Z-EVO	7/8"	1/2"	125	75	913	416	1149	15
3508029	PAC4568Z-EVO	7/8"	1/2"	126	75	913	416	1149	15
3508030	PAC4573Z-EVO	7/8"	1/2"	127	76	913	416	1149	15

Capacities

Product Code	Model Number	Ambient Temperature: °C	Capacity: Watts														
			Evaporating Temperature: °C														
			R404A					R448A					R452A				
			-10	-5	0	5	10	-10	-5	0	5	10	-10	-5	0	5	10
3508016	PACS4517Z	30	2683	3251	3890	4604	5394	2548	3141	3817	4581	5437	2646	3228	3887	4625	5444
		32	2592	3142	3761	4451	5214	2462	3038	3695	4437	5269	2554	3118	3756	4470	5263
		38	2318	2814	3370	3990	4675	2204	2731	3330	4008	4768	2277	2787	3362	4005	4720
		43	2087	2539	3043	3604	4224	1992	2478	3030	3654	4355	2046	2511	3033	3618	4268
		30	3406	4122	4916	5789	6743	3246	3996	4840	5782	6823	3364	4097	4915	5818	6808
3508018	PACS4519Z	32	3293	3987	4756	5601	6523	3138	3868	4689	5604	6617	3248	3960	4752	5627	6586
		38	2944	3574	4267	5025	5851	2811	3481	4231	5068	5993	2895	3542	4257	5045	5908
		43	2647	3222	3850	4535	5281	2538	3157	3849	4619	5472	2597	3187	3838	4553	5336
		30	3874	4756	5730	6795	7951	3711	4633	5668	6820	8089	3832	4735	5737	6839	8039
		32	3730	4588	5533	6566	7685	3575	4474	5482	6604	7840	3686	4564	5537	6606	7770
3508132	PACS44524Z-EVO-XC	38	3291	4074	4932	5865	6875	3160	3989	4917	5949	7087	3242	4044	4928	5898	6953
		43	2917	3637	4420	5269	6187	2813	3583	4444	5400	6456	2866	3603	4413	5298	6262
		30	4984	6010	7093	8246	9479	4764	5840	7007	8278	9661	4915	5965	7082	8281	9569
		32	4791	5798	6855	7975	9169	4585	5644	6787	8028	9377	4722	5752	6844	8009	9258
		38	4197	5150	6130	7152	8230	4041	5050	6124	7278	8525	4132	5106	6118	7185	8320
3508134	PACS4532Z-EVO-XC	43	3690	4599	5515	6457	7439	3581	4552	5571	6655	7820	3629	4557	5506	6493	7533
		30	6107	7409	8819	10327	11922	5864	7230	8736	10374	12138	6049	7380	8828	10384	12037
		32	5912	7174	8539	9995	11534	5678	7009	8473	10065	11779	5849	7141	8543	10049	11646
		38	5307	6454	7683	8986	10357	5108	6335	7678	9134	10699	5233	6409	7677	9031	10465
		43	4777	5831	6949	8127	9361	4618	5762	7008	8354	9798	4697	5780	6938	8169	9468
3508026	PAC4546Z	30	6853	8484	10275	12214	14286	6586	8296	10212	12326	14631	6771	8437	10277	12280	14432
		32	6553	8132	9865	11740	13745	6301	7962	9822	11879	14122	6469	8082	9863	11803	13889
		38	5664	7085	8642	10326	12130	5462	6974	8672	10554	12614	5577	7030	8634	10384	12269
		43	4939	6228	7637	9161	10795	4785	6175	7737	9474	11382	4852	6171	7627	9217	10935
		30	8135	10102	12293	14703	17321	7794	9842	12162	14756	17620	8039	10046	12294	14778	17490
3508027	PAC4553Z	32	7792	9693	11809	14136	16665	7466	9452	11701	14218	17000	7692	9633	11805	14207	16830
		38	6767	8476	10370	12450	14713	6496	8299	10342	12630	15167	6659	8405	10355	12509	14867
		43	5921	7473	9186	11063	13105	5706	7362	9236	11339	13675	5811	7398	9165	11117	13256
		30	9009	11063	13333	15806	18469	8624	10775	13191	15871	18807	8896	10996	13326	15879	18641
		32	8648	10636	12827	15215	17786	8282	10369	12713	15314	18166	8533	10564	12817	15285	17955
3508028	PAC4561Z	38	7572	9362	11326	13460	15758	7269	9172	11305	13674	16277	7450	9283	11307	13522	15921
		43	6678	8311	10090	12016	14088	6440	8197	10161	12342	14742	6554	8228	10067	12075	14252
		30	10333	12549	14986	17633	20478	9898	12245	14875	17789	20982	10206	12483	15001	17751	20722
		32	9954	12110	14476	17045	19805	9542	11833	14400	17245	20363	9825	12041	14487	17160	20047
		38	8813	10784	12937	15268	17772	8479	10603	12981	15617	18513	8679	10708	12941	15377	18011
3508029	PAC4568Z	43	7858	9672	11644	13775	16062	7604	9589	11810	14273	16982	7722	9593	11646	13885	16305
		30	11009	13313	15833	18556	21466	10545	12989	15714	18717	21986	10868	13231	15831	18655	21687
		32	10606	12837	15273	17905	20715	10162	12538	15187	18106	21285	10460	12749	15265	17998	20931
		38	9377	11387	13573	15927	18442	9007	11179	13599	16267	19180	9219	11285	13550	16007	18648
		43	8337	10161	12135	14259	16526	8045	10047	12276	14737	17428	8174	10053	12107	14335	16732

Capacities based on EN13215 Midpoint ratings: Return Vapour 20°C, Subcooling 3K

COMPAC Hermetic.

Low temperature applications - R404A/R448A/R452A

Single phase

Product Code	Unit Model	Compressor					Fan(s)				Liquid Receiver Capacity kg @ 80%
		Tecumseh Model	Displ. cm ³ /rev	Nominal HP	MOC Amps	Volts / Phase	No. Diam. Mm	MOC Amps	Air Flow m ³ /hr	Volts / Phase	
3508139	PACS2480Z-XC	FH2480Z-XC3A	54.3	2.00	11.1	240/1	1 x 450	1.15	5050	240/1	3.9
3508141	PACS2511Z-XC	FH2511Z-XC3A	68.0	2.75	12.2	240/1	1 x 450	1.15	5050	240/1	3.9

Three phase

Product Code	Unit Model	Compressor					Fan(s)				Liquid Receiver Capacity kg @ 80%
		Tecumseh Model	Displ. cm ³ /rev	Nominal HP	MOC Amps	Volts / Phase	No. Diam. Mm	MOC Amps	Air Flow m ³ /hr	Volts / Phase	
3508140	PAC2480Z-EVO	FH2480Z-XG1A	54.3	2.0	3.6	415/3	1 x 450	1.15	5050	240/1	3.9
3508142	PAC2511Z-XG	FH2511Z-XG1A	68.0	2.8	5.2	415/3	1 x 450	1.15	5050	240/1	3.9
3508035	PAC2513Z-EVO	TAG2513Z	100.7	3.2	6.4	415/3	1 x 500	1.75	6720	240/1	3.9
3508036	PAC2516Z-EVO	TAG2516Z	112.5	4.0	7.1	415/3	1 x 500	1.75	6720	240/1	3.9
3508037	PAC2522Z-EVO	TAG2522Z	134.8	5.5	9.1	415/3	2 x 450	2.3	10100	240/1	9.5
3508038	PAC2525Z-EVO	TAG2525Z	145	6.2	9.8	415/3	2 x 450	2.3	10100	240/1	9.5

Dimension properties

Product Code	Unit Model	Unit connections		Weight	Sound Power Level	Dimensions			Drawing No.
		Suction	Liquid			L mm	W mm	H mm	
3508139	PACS2480Z-XC	5/8"	3/8"	86	69	913	416	633	13
3508140	PAC2480Z-XG	5/8"	3/8"	82	69	913	416	633	13
3508141	PACS2511Z-XC	5/8"	3/8"	86	70	913	416	633	13
3508142	PAC2511Z-XG	5/8"	3/8"	82	70	913	416	633	13
3508035	PAC2513Z-EVO	7/8"	1/2"	104	71	913	416	792	14
3508036	PAC2516Z-EVO	7/8"	1/2"	103	71	913	416	792	14
3508037	PAC2522Z-EVO	7/8"	1/2"	130	76	913	416	1149	15
3508038	PAC2525Z-EVO	7/8"	1/2"	129	77	913	416	1149	15

Capacities

Product Code	Model Number	Ambient Temperature: °C	Capacity: Watts																	
			Evaporating Temperature: °C																	
			R404A					R448A					R452A							
			-30	-25	-23.3	-20	-15	-30	-25	-23.3	-20	-15	-40	-35	-30	-25	-23.3	-20	-15	-10
3508139	PACS2480Z-XC	32	1861	2423	2625	3031	3687	1386	1935	2144	2585	3345	711	1128	1631	2230	2458	2935	3754	4693
		35	1759	2308	2506	2906	3559	1288	1819	2021	2448	3184	628	1035	1523	2103	2322	2783	3573	4481
		38	1663	2198	2392	2787	3437	1190	1703	1898	2311	3023	543	938	1412	1972	2183	2628	3391	4267
		43	1516	2027	2215	2600	3245	1026	1510	1695	2083	2756	400	776	1223	1749	1948	2366	3082	3906
3508140	PAC2480Z-XG	32	1940	2530	2741	3168	3864	1393	1913	2110	2522	3229	757	1159	1639	2203	2416	2860	3618	4483
		35	1836	2414	2622	3045	3739	1298	1803	1994	2397	3088	675	1066	1532	2081	2288	2720	3457	4301
		38	1739	2303	2508	2926	3619	1204	1696	1882	2275	2949	594	973	1425	1958	2159	2579	3297	4120
		43	1592	2133	2331	2742	3431	1054	1522	1701	2077	2728	458	819	1249	1756	1947	2348	3035	3826
3508141	PACS2511Z-XC	32	2440	3236	3535	4157	5216	1928	2686	2977	3598	4683	958	1520	2232	3110	3452	4182	5460	6965
		35	2306	3084	3376	3988	5037	1801	2534	2818	3421	4480	860	1401	2079	2921	3247	3944	5170	6615
		38	2181	2937	3224	3826	4864	1674	2384	2660	3247	4279	763	1281	1929	2733	3043	3710	4884	6268
		43	1988	2710	2987	3571	4592	1464	2138	2400	2960	3949	603	1084	1682	2421	2707	3322	4406	5693
3508142	PAC2511Z-XG	32	2440	3236	3535	4157	5216	1903	2662	2956	3583	4683	1020	1562	2242	3072	3393	4074	5263	6654
		35	2306	3084	3376	3988	5037	1773	2500	2783	3388	4452	925	1443	2092	2890	3199	3855	5002	6349
		38	2181	2937	3224	3826	4864	1648	2346	2618	3201	4231	834	1328	1948	2714	3010	3641	4748	6053
		43	1988	2710	2987	3571	4592	1452	2105	2359	2908	3884	690	1144	1718	2430	2706	3297	4339	5576
3508035	PAC2513Z-EVO	32	2829	3940	4364	5256	6782	2139	3110	3489	4300	5719	996	1674	2539	3615	4033	4920	6465	8258
		35	2587	3644	4047	4896	6350	1949	2874	3236	4010	5372	856	1501	2324	3349	3747	4596	6076	7798
		38	2353	3354	3738	4545	5929	1767	2645	2990	3730	5036	721	1333	2115	3090	3469	4278	5695	7348
		43	1988	2903	3254	3993	5267	1485	2293	2612	3298	4517	511	1072	1788	2684	3034	3781	5096	6643
3508036	PAC2516Z-EVO	32	3382	4472	4879	5727	7169	2593	3572	3946	4735	6106	1386	2147	3053	4124	4531	5386	6864	8585
		35	3196	4259	4660	5495	6923	2448	3406	3774	4556	5922	1282	2012	2889	3937	4338	5184	6655	8382
		38	3021	4058	4450	5271	6686	2312	3250	3614	4387	5752	1186	1886	2734	3760	4155	4991	6456	8190
		43	2754	3743	4120	4920	6313	2111	3018	3374	4137	5502	1046	1697	2498	3486	3869	4691	6148	7897
3508037	PAC2522Z-EVO	32	4298	5760	6319	7499	9542	3296	4602	5111	6200	8127	1790	2719	3880	5313	5868	7053	9136	11595
		35	4020	5417	5951	7079	9034	3079	4331	4821	5869	7728	1628	2522	3635	5008	5541	6679	8684	11057
		38	3745	5078	5587	6663	8530	2866	4067	4537	5546	7338	1465	2324	3390	4706	5217	6309	8237	10525
		43	3292	4519	4987	5978	7704	2524	3644	4083	5027	6714	1192	1996	2987	4208	4683	5700	7503	9656
3508038	PAC2525Z-EVO	32	4624	6085	6626	7739	9578	3546	4872	5375	6430	8224	1951	2960	4180	5628	6174	7312	9235	11391
		35	4314	5709	6225	7287	9039	3305	4580	5064	6079	7811	1760	2733	3905	5294	5818	6911	8756	10830
		38	4009	5339	5831	6842	8508	3072	4297	4763	5741	7413	1573	2509	3633	4966	5467	6515	8286	10283
		43	3527	4754	5206	6134	7666	2716	3863	4300	5220	6799	1277	2156	3204	4443	4910	5886	7542	9423

EN13215 ratings
Return gas 20°C | Superheat 55k | Subcooling 3k

COMPAC Hermetic.

Medium temperature applications - R134a/R513A

Single phase

Product Code	Unit Model	Compressor					Fan(s)				Liquid Receiver Capacity kg @ 80%
		Tecumseh Model	Displ. cm ³ /rev	Nominal HP	MOC Amps	Volts / Phase	No. Diam. Mm	MOC Amps	Air Flow m ³ /hr	Volts / Phase	
3508064	PACS4476Y-EVO	CAJ4476Y	21.8	0.7	7.5	240/1	1 x 450	1.15	5050	240/1	3.9
3508065	PACS4492Y-EVO	CAJ4492Y	25.9	0.75	9.6	240/1	1 x 450	1.15	5050	240/1	3.9
3508067	PACS4511Y-EVO	CAJ4511Y	32.7	1	9.3	240/1	1 x 450	1.15	5050	240/1	3.9
3508143	PACS4518N-EVO-XC	FH4518N-XC	53.2	1.5	11.1	240/1	1 x 450	1.15	5050	240/1	3.9
3508145	PACS4525N-EVO-XC	FH4525N-XC	74.2	2	14.4	240/1	1 x 450	1.15	5050	240/1	3.9

Three phase

Product Code	Unit Model	Compressor					Fan(s)				Liquid Receiver Capacity kg @ 80%
		Tecumseh Model	Displ. cm ³ /rev	Nominal HP	MOC Amps	Volts / Phase	No. Diam. Mm	MOC Amps	Air Flow m ³ /hr	Volts / Phase	
3508066	PAC4492Y-EVO	TAJ4492Y	25.9	0.75	3.5	415/3	1 x 450	1.15	5050	240/1	3.9
3508068	PAC4511Y-EVO	TAJ4511Y	32.7	1	3.7	415/3	1 x 450	1.15	5050	240/1	3.9
3508144	PAC4518N-EVO-XG	FH4518N-XG	53.2	1.5	5.2	415/3	1 x 450	1.15	5050	240/1	3.9
3508146	PAC4525N-EVO-XG	FH4525N-XG	74.2	2	7.2	415/3	1 x 450	1.15	5050	240/1	3.9
3508073	PAC4528Y-EVO	TAG4528Y	90.2	2.3	11.2	415/3	1 x 500	1.75	6720	240/1	3.9
3508074	PAC4534Y-EVO	TAG4534Y	100.7	2.8	11.5	415/3	1 x 500	1.75	6720	240/1	3.9
3508075	PAC4537Y-EVO	TAG4537Y	112.5	3	11.2	415/3	1 x 500	1.75	6720	240/1	3.9
3508076	PAC4543Y-EVO	TAG4543Y	124.4	3.6	11.4	415/3	1 x 500	1.75	6720	240/1	3.9

Dimension properties

Product Code	Unit Model	Unit connections		Weight	Sound Power Level	Dimensions			Drawing No.
		Suction	Liquid			L mm	W mm	H mm	
3508064	PACS4476Y-EVO	1/2"	3/8"	67	68	913	465	633	13
3508065	PACS4492Y-EVO	5/8"	3/8"	67	68	913	465	633	13
3508066	PAC4492Y-EVO	5/8"	3/8"	66	68	913	465	633	13
3508067	PACS4511Y-EVO	5/8"	3/8"	67	68	913	465	633	13
3508068	PAC4511Y-EVO	5/8"	3/8"	66	68	913	465	633	13
3508143	PACS4518N-EVO-XC	5/8"	3/8"	78	68	913	465	633	13
3508144	PAC4518N-EVO-XG	5/8"	3/8"	77	68	913	465	633	13
3508145	PAC4525N-EVO-XC	5/8"	3/8"	79	70	913	465	633	13
3508146	PAC4525N-EVO-XG	5/8"	3/8"	78	70	913	465	633	13
3508073	PAC4528Y-EVO	7/8"	1/2"	102	72	913	478	792	14
3508074	PAC4534Y-EVO	7/8"	1/2"	102	72	913	478	792	14
3508075	PAC4537Y-EVO	7/8"	1/2"	102	72	913	478	792	14
3508076	PAC4543Y-EVO	7/8"	1/2"	102	72	913	478	792	14

Medium temperature applications - R134a/R513A

Capacities

Product Code	Model Number	Ambient Temperature: °C	Capacity: Watts									
			Evaporating Temperature: °C									
			R134a					R513A				
			-10	-5	0	5	10	-10	-5	0	5	10
3508064	PACS4476Y	30	1136	1439	1788	2184	2632	1173	1477	1830	2239	2706
		32	1099	1396	1737	2125	2563	1131	1428	1774	2173	2629
		38	985	1263	1581	1943	2351	1006	1281	1602	1973	2398
		43	887	1148	1447	1787	2171	899	1158	1458	1806	2204
3508065	PACS4492Y	30	1388	1758	2182	2664	3205	1508	1856	2248	2685	3167
		32	1345	1705	2119	2588	3116	1461	1799	2179	2602	3068
		38	1213	1547	1929	2362	2849	1318	1629	1975	2356	2775
		43	1100	1414	1771	2175	2628	1196	1487	1806	2156	2537
3508067	PACS4511Y	30	1795	2238	2739	3299	3918	1948	2361	2817	3317	3858
		32	1744	2176	2665	3211	3814	1891	2293	2736	3220	3743
		38	1587	1989	2441	2944	3501	1720	2089	2492	2930	3400
		43	1452	1829	2251	2720	3237	1573	1917	2288	2688	3116
3508068	PAC4511Y	30	1778	2224	2727	3289	3911	1929	2347	2807	3309	3854
		32	1726	2162	2653	3202	3808	1871	2278	2725	3213	3740
		38	1566	1972	2426	2933	3493	1695	2069	2477	2919	3395
		43	1431	1810	2233	2705	3225	1547	1893	2268	2671	3105
3508069	PACS4518Y	30	2477	3201	4032	4975	6032	2571	3292	4122	5063	6119
		32	2396	3107	3922	4847	5884	2482	3189	4000	4921	5954
		38	2143	2813	3580	4450	5424	2207	2869	3626	4485	5447
		43	1922	2557	3283	4105	5027	1969	2593	3305	4111	5014
3508070	PAC4518Y	30	2484	3214	4054	5010	6085	2579	3305	4144	5099	6172
		32	2405	3120	3943	4879	5931	2491	3202	4021	4953	6001
		38	2159	2829	3598	4473	5456	2223	2884	3644	4508	5479
		43	1947	2578	3301	4124	5050	1995	2614	3323	4130	5036
3508071	PACS4525Y	30	3597	4532	5585	6757	8043	3720	4641	5680	6836	8102
		32	3483	4398	5429	6574	7831	3596	4496	5509	6636	7871
		38	3136	3991	4951	6018	7188	3219	4055	4993	6033	7173
		43	2840	3644	4546	5547	6646	2901	3683	4558	5528	6590
3508072	PAC4525Y	30	3520	4435	5477	6645	7939	3637	4540	5568	6722	7999
		32	3393	4288	5305	6447	7714	3501	4380	5383	6508	7755
		38	3024	3854	4800	5864	7047	3103	3915	4840	5881	7036
		43	2727	3504	4391	5391	6505	2785	3541	4403	5374	6454
3508073	PAC4528Y	30	3194	4434	5864	7460	9194	4274	5389	6664	8101	9698
		32	3090	4297	5691	7246	8938	4118	5203	6443	7839	9393
		38	2779	3887	5171	6607	8171	3656	4655	5792	7071	8493
		43	2520	3545	4738	6075	7532	3276	4208	5262	6446	7762
3508074	PAC4534Y	30	4143	5484	7021	8723	10562	4701	5915	7297	8845	10557
		32	4008	5314	6812	8472	10265	4529	5711	7054	8559	10223
		38	3603	4804	6185	7718	9374	4019	5107	6338	7716	9238
		43	3264	4378	5663	7090	8633	3600	4614	5755	7029	8436

COMPAC Hermetic.

Capacities

Product Code	Model Number	Ambient Temperature: °C	Capacity: Watts									
			Evaporating Temperature: °C									
			R134a					R513A				
			-10	-5	0	5	10	-10	-5	0	5	10
3508075	PAC4537Y	30	4708	6160	7825	9666	11646	5177	6500	7998	9667	11501
		32	4554	5968	7591	9386	11316	4987	6275	7731	9354	11137
		38	4091	5392	6888	8545	10327	4424	5610	6945	8430	10061
		43	3705	4912	6303	7845	9504	3960	5066	6304	7678	9184
3508076	PAC4543Y	30	4876	6400	8192	10200	12371	5653	7079	8685	10463	12401
		32	4715	6200	7946	9902	12017	5445	6834	8395	10123	12007
		38	4234	5599	7207	9010	10958	4829	6109	7540	9121	10843
		43	3833	5098	6592	8268	10076	4322	5515	6843	8304	9893

Capacities based on EN13215 Midpoint ratings: Return Vapour 20°C, Subcooling 3K

Dimensional Drawings

Drawing 13

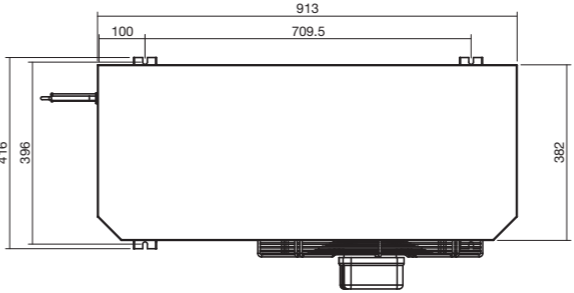

Drawing 14

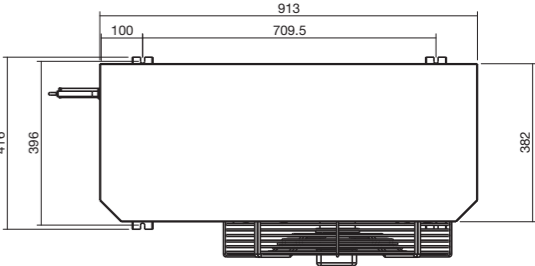

Drawing 15

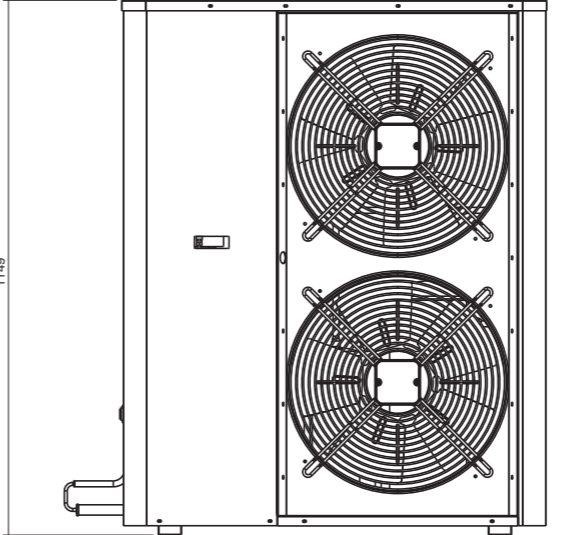
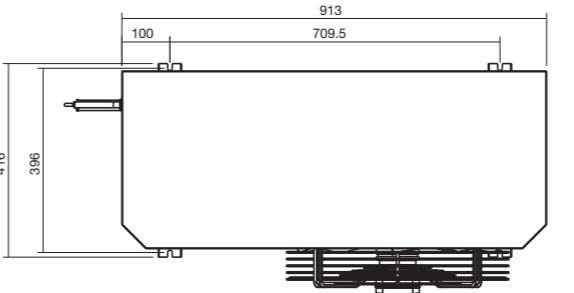

section six

COMPAC scroll.

COMPAC scroll.



The smooth operators.

The Compac Scroll series is a range of fully fitted packaged units featuring world leading Tecumseh Scroll compressors. The Scroll compressor allows for an ultra smooth and efficient operation due to the true rotating motion which enables dynamic balancing. Designed with space constraints in mind, the horizontal discharge condenser configuration suits unit placement in car parks, roofs, on the side of buildings and mounted above one another without restricting airflow.

Installation is simple as every COMPAC is optioned straight out of the box. Once installed, you can relax knowing the premium compressors and large condensers will deliver reliable refrigeration when you need it most.

Every COMPAC is built with high quality, corrosion resistant components, and extensive testing is completed on each unit, to ensure long life in the field. What's more, electronic overload protects against phase loss, imbalance, reversal, locked rotor and over-current to ensure excellent compressor protection.

Standard features

- Small footprint. Housing is designed to optimise spacing
- Large epoxy finned condenser
- Oil separator on every model
- Suction accumulator on all models
- Powder coated galvanised steel casing
- Light weight design
- Easy servicing - mechanical & electrical components in same compartment
- Factory leak tested
- Fan cycle control
- Electrical panel is fully wired to all electrical components
- Separate compressor and fan compartment for safe and easy maintenance
- Safety controls offering substantial protection
- Integrated discharge check valve prevents reverse rotation on shutdown, eliminating noise from pressure equalisation through the scroll set.

COMPAC scroll.

Medium temperature applications - R404A/R448A/R452A/R134a/R513A

Product Code	Unit Model	Compressor					Fan(s)				Liquid Receiver Capacity kg @ 80%
		Tecumseh Model	Displ. cm ³ /rev	Nominal HP	MOC Amps	Volts / Phase	No. Diam. Mm	MOC Amps	Air Flow m ³ /hr	Volts / Phase	
3508116	PASS4524Z-1	VSE9515ZFZ	5.8	2.0	16.2	240/1	1 x 450	1.15	5050	240/1	3.9
3508117	PAS4530Z-3	VSE9519ZXG	7.3	2.5	6.4	415/3	1 x 500	1.75	6720	240/1	3.9
3508118	PAS4548Z-3	VSE9530ZXG	11.8	4.0	10.3	415/3	1 x 500	1.75	6720	240/1	3.9
3508119	PAS4560Z-3	VSE9538ZXG	14.5	5.0	12.2	415/3	2 x 450	2.30	10100	240/1	9.5
3508120	PAS4572Z-3	VSE9545ZXG	17.1	6.0	14.3	415/3	2 x 450	2.30	10100	240/1	9.5
3508121	PAS4584Z-3	VSE9548ZXG	18.8	7.0	17.1	415/3	2 x 500	3.50	13440	240/1	9.5
3508122	PAS4596Z-3	VSE9558ZXG	21.4	8.0	18.4	415/3	2 x 500	3.50	13440	240/1	9.5
3508123	PAS4611Z-3	VSE9566ZXG	25.3	9.0	21.0	415/3	2 x 500	3.50	13440	240/1	9.5
3508124	PAS4612Z-3	VSE9576ZXG	29.1	10.0	23.6	415/3	2 x 500	3.50	13440	240/1	9.5
3508125	PAS4614Z-3	VSE9595ZXG	34.3	12.0	27.6	415/3	4 x 500	7.00	26880	240/1	12

Dimension properties

Product Code	Unit Model	Unit connections		Weight kg	Sound Power Level dBA	Dimensions			Drawing No.
		Suction	Liquid			L mm	W mm	H mm	
3508116	PASS4524Z-1	5/8"	3/8"	80	71	913	416	638	13
3508117	PAS4530Z-3	7/8"	1/2"	82	73	913	416	792	14
3508118	PAS4548Z-3	7/8"	1/2"	83	73	913	416	792	14
3508119	PAS4560Z-3	7/8"	1/2"	110	73	913	416	1149	15
3508120	PAS4572Z-3	7/8"	1/2"	112	74	913	416	1149	15
3508121	PAS4584Z-3	7/8"	1/2"	140	75	913	416	1271	16
3508122	PAS4596Z-3	1-1/8"	1/2"	140	75	913	416	1271	16
3508123	PAS4611Z-3	1-1/8"	1/2"	140	75	913	416	1271	16
3508124	PAS4612Z-3	1-1/8"	1/2"	141	75	913	416	1271	16
3508125	PAS4614Z-3	1-1/8"	5/8"	178	79	1715	520	1290	17

Medium temperature applications - R404A/R448A/R452A/R134a/R513A

Capacities

Product Code	Model Number	Ambient Temperature: °C	Capacity: Watts														
			Evaporating Temperature: °C														
			R404A					R448A					R452A				
			-15	-10	-5	0	5	-15	-10	-5	0	5	-15	-10	-5	0	5
3508116	PASS4524Z-1	30	3627	4331	5129	6027	7031	3554	4263	5077	6007	7061	3520	4253	5090	6036	7094
		32	3543	4225	4999	5871	6843	3475	4169	4963	5869	6899	3430	4145	4960	5881	6911
		38	3279	3900	4600	5388	6269	3220	3867	4605	5446	6401	3150	3813	4564	5410	6356
		43	3044	3611	4250	4968	5772	2982	3593	4287	5076	5972	2902	3522	4221	5006	5883
3508117	PAS4530Z-3	30	4366	5221	6194	7294	8526	4275	5135	6124	7256	8546	4240	5129	6148	7304	8602
		32	4265	5095	6040	7106	8302	4182	5022	5988	7093	8352	4133	5001	5994	7120	8383
		38	3953	4709	5566	6533	7617	3882	4667	5564	6590	7759	3801	4607	5523	6558	7720
		43	3675	4368	5151	6034	7026	3601	4344	5189	6152	7250	3507	4262	5116	6078	7156
3508118	PAS4548Z-3	30	6862	8145	9581	11175	12929	6736	8044	9527	11201	13077	4508	5539	6704	8002	9432
		32	6696	7940	9331	10874	12571	6578	7856	9302	10934	12765	4353	5350	6477	7736	9124
		38	6178	7303	8554	9941	11469	6067	7257	8598	10109	11804	3896	4795	5815	6957	8221
		43	5711	6734	7869	9125	10510	5587	6710	7968	9383	10969	3532	4352	5285	6332	7496
3508119	PAS4560Z-3	30	8579	10219	12070	14143	16443	8411	10072	11969	14125	16559	6347	7812	9466	11312	13349
		32	8377	9968	11763	13772	16001	8222	9845	11696	13799	16174	6124	7541	9140	10925	12898
		38	7748	9193	10815	12629	14644	7609	9124	10842	12792	14996	5473	6748	8187	9795	11575
		43	7185	8505	9982	11632	13468	7035	8466	10082	11911	13978	4956	6117	7426	8891	10514
3508120	PAS4572Z-3	30	10046	11932	14045	16395	18982	9860	11780	13959	16422	19185	7904	9676	11665	13869	16284
		32	9806	11634	13680	15954	18460	9632	11507	13632	16034	18729	7647	9364	11291	13427	15768
		38	9052	10706	12550	14596	16852	8889	10636	12608	14832	17329	6880	8434	10178	12112	14236
		43	8373	9879	11552	13407	15455	8192	9842	11693	13776	16115	6257	7677	9270	11038	12984
3508121	PAS4584Z-3	30	9734	11777	13988	16362	18891	9760	11941	14427	17232	20368	9386	11442	13683	16096	18670
		32	9390	11369	13509	15807	18256	9446	11571	13997	16739	19808	9031	11020	13188	15523	18015
		38	8357	10145	12076	14146	16354	8522	10483	12731	15283	18155	7974	9769	11723	13829	16079
		43	7499	9129	10885	12767	14776	7779	9604	11705	14103	16813	7114	8753	10535	12455	14509
3508122	PAS4596Z-3	30	12350	14555	16984	19634	22499	12142	14421	16971	19809	22947	10789	13060	15552	18246	21120
		32	12037	14170	16515	19072	21837	11836	14060	16544	19308	22365	10400	12592	14999	17602	20380
		38	11047	12959	15050	17328	19793	10839	12903	15198	17746	20565	9244	11207	13363	15697	18195
		43	10146	11871	13749	15792	18007	9902	11843	13988	16364	18990	8304	10082	12035	14151	16420
3508123	PAS4611Z-3	30	15692	18620	21897	25532	29526	15405	18392	21777	25595	29873	13275	16157	19367	22894	26725
		32	15313	18152	21325	24841	28707	15044	17961	21263	24986	29159	12820	15607	18713	22128	25839
		38	14128	16694	19548	22709	26188	13873	16590	19651	23098	26962	11459	13969	16767	19850	23209
		43	13058	15393	17980	20842	23996	12774	15338	18211	21438	25055	10338	12624	15174	17987	21058
3508124	PAS4612Z-3	30	17469	20677	24245	28179	32476	17160	20448	24156	28318	32957	15048	18239	21780	25653	29837
		32	17040	20147	23599	27402	31556	16748	19957	23572	27629	32152	14530	17615	21037	24781	28828
		38	15692	18492	21588	24995	28721	15405	18392	21739	25489	29672	12985	15757	18829	22193	25835
		43	14471	17011	19808	22882	26250	14145	16959	20097	23603	27512	11720	14238	17026	20079	23389
3508125	PAS4614Z-3	30	20720	24677	29143	34140	39683	20317	24326	28902	34102	39970	19007	23323	28166	33529	39403
		32	20233	24073	28402	33244	38615	19860	23777	28242	33314	39041	18310	22498	27202	32418	38136
		38	18714	22199	26111	30483	35339	18378	22033	26179	30882	36195	16237	20050	24348	29130	34392
		43	17351	20536	24098	28075	32498	16990	20444	24342	28753	33735	14554	18064	22032	26463	31355

COMPAC scroll.

Capacities

Product Code	Model Number	Ambient Temperature: °C	Capacity: Watts											
			Evaporating Temperature: °C											
			R134a						R513A					
			-15	-10	-5	0	5	10	-15	-10	-5	0	5	10
3508116	PASS4524Z-1	30	1940	2429	3012	3685	4442	5277	2122	2625	3216	3890	4642	5466
		32	1898	2381	2957	3622	4370	5194	2073	2568	3150	3815	4557	5369
		38	1769	2230	2782	3418	4134	4923	1921	2386	2938	3570	4277	5053
		43	1662	2100	2626	3235	3920	4677	1795	2229	2749	3349	4022	4762
3508117	PAS4530Z-3	30	2325	2912	3614	4423	5334	6340	2546	3150	3862	4674	5580	6574
		32	2276	2856	3549	4348	5249	6242	2487	3082	3784	4585	5479	6461
		38	2123	2676	3340	4107	4971	5924	2306	2867	3532	4295	5149	6089
3508118	PAS4548Z-3	30	3720	4651	5758	7030	8452	10012	4060	5012	6127	7394	8798	10329
		32	3639	4557	5649	6903	8306	9843	3964	4899	5996	7242	8625	10132
		38	3390	4262	5303	6498	7835	9299	3670	4545	5578	6756	8066	9495
		43	3184	4010	4999	6139	7414	8812	3429	4242	5212	6324	7565	8922
3508119	PAS4560Z-3	30	4610	5768	7149	8739	10523	12486	5039	6228	7624	9213	10981	12914
		32	4510	5654	7017	8587	10347	12284	4922	6091	7465	9031	10773	12679
		38	4204	5294	6596	8096	9780	11631	4560	5658	6957	8442	10099	11914
		43	3950	4984	6225	7658	9268	11040	4261	5285	6508	7915	9490	11219
3508120	PAS4572Z-3	30	5438	6800	8420	10282	12365	14650	5937	7330	8963	10818	12877	15121
		32	5319	6663	8261	10097	12152	14405	5797	7166	8772	10597	12624	14834
		38	4956	6233	7757	9508	11467	13615	5368	6650	8163	9890	11811	13909
		43	4655	5865	7314	8984	10854	12905	5015	6208	7630	9261	11082	13075
3508121	PAS4584Z-3	30	6054	7561	9349	11397	13678	16170	6597	8132	9925	11955	14199	16634
		32	5920	7405	9167	11184	13432	15885	6439	7944	9706	11701	13907	16301
		38	5512	6920	8594	10512	12647	14976	5958	7362	9015	10894	12976	15238
		43	5176	6507	8096	9918	11951	14167	5565	6868	8415	10184	12149	14290
3508122	PAS4596Z-3	30	6814	8503	10503	12786	15323	18084	7416	9129	11128	13383	15869	18557
		32	6661	8325	10294	12542	15039	17754	7236	8916	10877	13091	15533	18173
		38	6200	7773	9641	11773	14139	16710	6692	8254	10090	12170	14466	16953
		43	5822	7306	9075	11098	13345	15787	6251	7696	9410	11363	13526	15873
3508123	PAS4611Z-3	30	8512	10641	13174	16080	19331	22895	9290	11466	14016	16909	20119	23615
		32	8326	10425	12923	15790	18995	22507	9070	11207	13714	16562	19721	23163
		38	7756	9751	12130	14863	17917	21262	8398	10397	12758	15449	18441	21704
		43	7285	9174	11436	14040	16953	20145	7845	9705	11921	14461	17295	20393
3508124	PAS4612Z-3	30	9535	11913	14736	17970	21579	25524	10396	12819	15654	18865	22417	26278
		32	9325	11668	14451	17639	21194	25079	10148	12526	15311	18467	21961	25758
		38	8683	10907	13553	16585	19966	23658	9391	11611	14227	17204	20504	24095
		43	8156	10257	12769	15654	18874	22391	8772	10834	13285	16088	19208	22609
3508125	PAS4614Z-3	30	11465	14525	18071	22123	26700	31817	11511	14581	18139	22205	26800	31939
		32	11107	14110	17590	21569	26065	31094	11154	14166	17659	21653	26167	31219
		38	10047	12873	16153	19910	24163	28928	10094	12931	16225	19999	24272	29063
		43	9179	11855	14966	18535	22582	27125	9227	11915	15041	18628	22698	27269

Capacities based on EN13215 Midpoint ratings: Return Vapour 20°C, Subcooling 3K

Dimensional Drawings

COMPAC Scroll (Small)

COMPAC Scroll (Medium)

COMPAC Scroll (Large)

Drawing 13

Drawing 14

Drawing 15

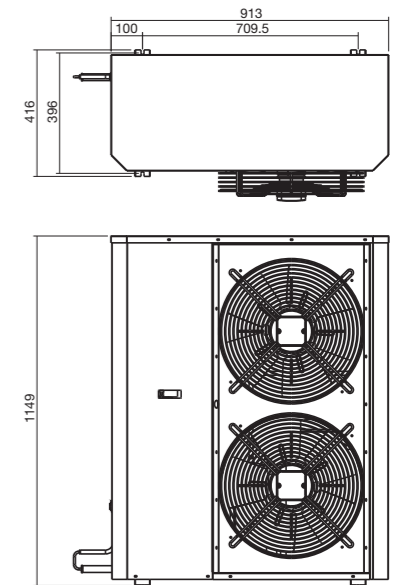
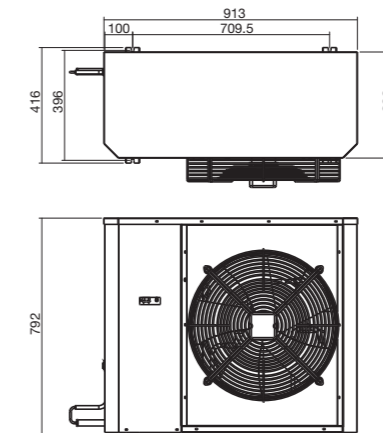
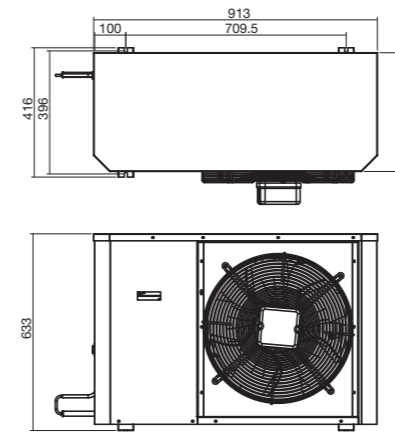

COMPAC Scroll (X Large)

COMPAC Scroll (XX Large)

Drawing 16

Drawing 17

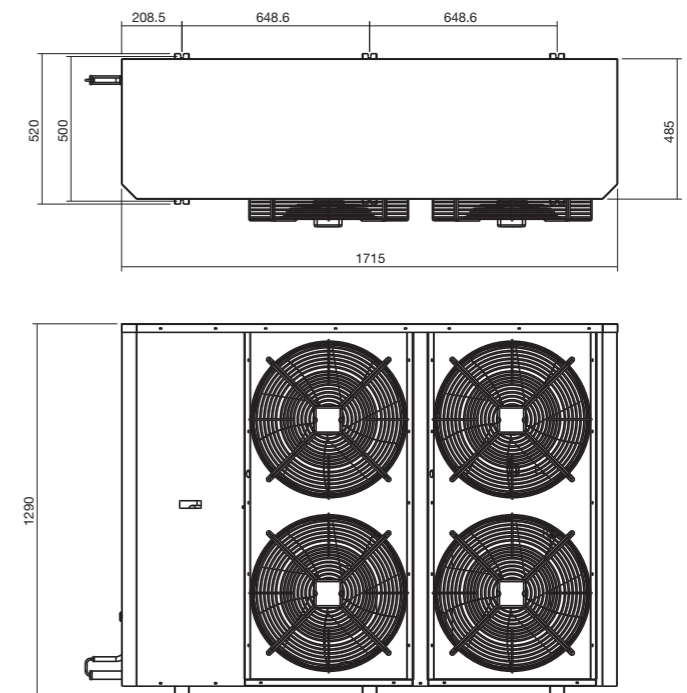
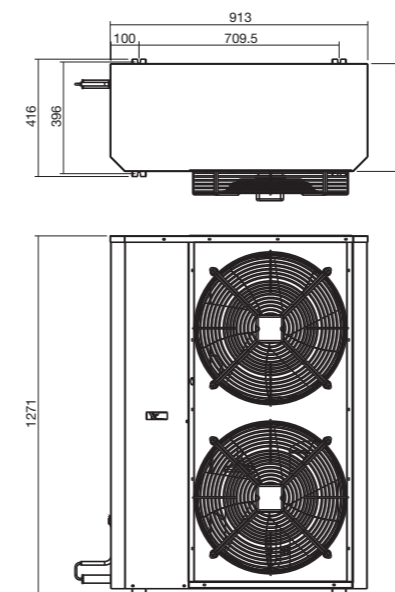

ACTROL

Visit actrol.com.au for your nearest branch.

The manufacturer/distributor reserves the right to vary specifications or delete models from their range without prior notification. The manufacturer/distributor takes no responsibility for printing errors. All dimensions are nominal only.

V1 [BROCHURE CODE: 2110999]



tecumseh

ACTROL