



>B< Press

Fitting System



110 Years of Innovation

For more than 110 years, Conex Bänninger has been the recognised leader in plumbing fittings, accessories and valves globally – offering a range of innovative and highly versatile jointing solutions.

Since opening its doors in Giessen, Germany in 1909, Conex Bänninger has produced over 20 billion copper fittings, establishing an unrivalled reputation for outstanding quality, first class customer service and market leading expertise.

>B< Press is a versatile press fitting system for use with hard, half hard or annealed copper tube. The unique press indicator ensures a secure, life long, leak-proof joint every time.

Fast Facts

> OVER 20 BILLION FITTINGS SOLD WORLDWIDE
SINCE 1909

> CONEX BÄNNINGER >B< MARK INTRODUCED IN 1920

> OVER 900 STAFF WORKING ACROSS THE GLOBE

> CAPACITY TO PRODUCE 500 MILLION PIECES A YEAR

Contents

Key Features	4
Applications, Warranty, Approvals & Certifications	6
Fittings 15-50mm	12
>B< Press Valves	48
XL Fittings 65-100mm	58
Installation Requirements	74
The Tools	82
Frequently Asked Questions	93

> Key Features <

The >B< Press system moves beyond just being a quality fitting, it gives you the total press solution.

Designed for Australia

Developed in partnership with Reece, Conex Bänninger and Rothenberger to meet the specific needs of Australian plumbers.



Tool Service Support

To ensure optimal performance, your Rothenberger press tools can be serviced through the Reece Tool Service Department.



Extensive Testing

>B< Press fittings undergo rigorous internal testing to ensure they meet Australian standards and piping tolerances.



Training and Certification

Reece supports you with training and certification as well as expert advice whenever you need it.



>B< Press Water fittings are WaterMark approved and certified to AS3688.

>B< Press Gas fittings are OceanaMark approved and certified to AS3688.

Flame Free

Takes away the risk of fire on site and eliminates the need for a hot works permit and heavy equipment.



Lower Installed Cost

A professional fitting which is quick and simple to install, saving time and money.



Higher Productivity

Installation can be completed during working hours or public access by a single employee.



Superior Performance

Corrosion resistant, with a design life of 50 years that can be relied on long after installation.



Permanent Connection

A secure, permanent joint ensures the fitting cannot be tampered with.



Fully Certified

Extensive third-party certification offers peace of mind to the client, specifier and installer.



360 Detect Unpressed Indicator

>B< Press 15-50mm water fittings now come with our innovative '360 Detect' indicator making it easier than ever to identify an unpressed fitting during testing.



> Applications, Warranty, Approvals & Certifications <





Applications



>B< Press Water fittings are suitable for:

- Drinking water
- Heating water (non solar)
- Chilled water



>B< Press Gas fittings are suitable for:

- Natural gas and LPG
- Compressed air (with or without oil content)
- Fuel lines



>B< Press High Temperature fittings are suitable for:

- Solar hot water



Warranty

A 25 year warranty covers against faults caused by defective manufacture of the fittings. It does not cover faults arising from incorrect installation.

The warranty covers installation with type A and B copper tube conforming to AS1432 but does not cover any faults arising from competitor fittings used on the same installation nor faults caused by damaged >B< Press fittings (through excessive pressure, for example) where competitor fittings created non-compliant conditions.

All >B< Press fittings must be installed by a licensed plumber.

Approvals & Certifications



Conex Bänninger is an ISO 9000 quality assured company. In addition to WaterMark approvals in Australia, Conex Bänninger has approvals from numerous national and international bodies including DVGW, KIWA, GASTEC, WRAS and AENOR, plus many well-known others.



IAPMO R&T OCEANA

7-11 Fullard Road, Narra Warren, Victoria 3555, Australia



IAPMO R&T Oceana is a product certification body which inspects and arranges for the independent laboratory testing of samples taken from the manufacturer's stock or from the market or a combination of both, to verify compliance of the requirements of applicable Standards and Specifications. This activity is coupled with periodic surveillance of the certified product taken from the market place or the manufacturer's factory. This certification is subject to the conditions set forth in the characteristics below and is not to be construed as any recommendation, assurance or guarantee by IAPMO R&T Oceana of the product acceptance by Authorities Having Jurisdiction. The IAPMO R&T Oceana "OceanaMark" Product Certification Scheme is a JAS-ANZ accredited ISO Guide 67 Type 5 Product Certification Scheme.

OCEANAMARK LICENCE

IAPMO R&T Oceana hereby grants to:

Conex Universal Limited

Global House, 95 Vantage Point, The Pensnett Estate, Kingswinford, West Midlands, DY6 7FT, United Kingdom

the right to use the OceanaMark in accordance with IAPMO R&T Oceana Pty Ltd "Mark Rules" on the product as described in the attached OceanaMark Schedule. The Certificate is granted subject to IAPMO R&T Oceana Pty Ltd "Governance Rules".

Evaluated to:

AS 3688:2016

Water supply and gas systems-Metallic fittings and end-connectors

Manufacturer:

Refer to Licence Holder

Licence No.: OMK22197

First Certified: 15 June 2017

Certification Date: 17 November 2021

Expiry Date: 16 November 2026

CEO, The IAPMO Group

This OceanaMark certification is for the period indicated herein and is void after the date shown above. Any change in material, manufacturing process, marking or design without having first obtained the approval of IAPMO R&T Oceana, or any evidence of non-compliance with applicable Standards, Specifications or of inferior workmanship, may be deemed sufficient cause for revocation of this certification. Reproduction of or reference to this certificate for advertising purposes may be made only by specific written permission of IAPMO R&T Oceana. Any alteration of this certificate could be grounds for revocation of this certification.

IAPMO R&T OCEANA

7-11 Fullard Road, Narre Warren, Victoria 3885, Australia



IAPMO R&T Oceana is a product certification body which inspects and arranges for the independent laboratory testing of samples taken from the manufacturer's stock or from the market or a combination of both, to verify compliance of the requirements of applicable Standards and Specifications. This activity is coupled with periodic surveillance of the manufacturer's factory and any major subcontractor's sites as well as the assessment of the manufacturer's Quality Assurance System. This certification is subject to the conditions set forth in the characteristics below and is not to be construed as any recommendation, assurance or guarantee by IAPMO R&T Oceana of the product acceptance by Authorities Having Jurisdiction.

CERTIFICATE OF CONFORMITY

IAPMO R&T Oceana hereby grants to:

Conex Universal Limited

Global House, 95 Vantage Point, The Pensnett Estate, Kingswinford, West Midlands, DY6 7FT, United Kingdom

the right to use the WaterMark in accordance with the ABCB Manual for the WaterMark Certification Scheme - Australian Standards, WaterMark Technical Specifications, and the Plumbing Code of Australia, only in respect of the certified product as described in the WaterMark Certificate of Conformity - Schedule of Certified Product (Refer also IAPMO Product Listing Directory). The Certificate is granted subject to the rules governing the WaterMark Certification Scheme and the Terms and Conditions of the Approved User Agreement and IAPMO Oceana's WaterMark Governance Rules.

Evaluated to:

AS 5830.1-2012

In-line ball valves for use in plumbing water supply systems - Metal-bodied

Manufacturer:

Refer to Licence Holder

Licence No.: WM-022503

First Certified: 1 December 2016

Certification Date: 1 December 2021

Expiry Date: 30 November 2026

CEO, The IAPMO Group

This WaterMark certification is for the period indicated herein and is void after the date shown above. Any change in material, manufacturing process, marking or design without having first obtained the approval of IAPMO R&T Oceana, or any evidence of non-compliance with applicable Standards, Specifications or of inferior workmanship, may be deemed sufficient cause for revocation of this certification. Reproduction of or reference to this certificate for advertising purposes may be made only by specific written permission of IAPMO R&T Oceana. Any alteration of this certificate could be grounds for revocation of this certification.

This certificate is issued by a JAS-ANZ accredited Conformity Assessment Body. The ABCB and JAS-ANZ do not in any way warrant, guarantee or represent that the product the subject of this Certificate conforms to the WaterMark Certification Scheme Rules, nor accepts any liability arising out of the use of the product. The ABCB disclaims to the extent permitted by law, all liability (including negligence) for claims of losses, expenses, damages and costs arising as a result of the use of the product(s) referred to in this Certificate.

> Fittings 15-50mm <





Product Features

O-Ring

>B< Press fittings for water applications are identified with a black O-ring. For natural gas and LPG applications, fittings are identified by a yellow coloured O-ring and a yellow mark on the fitting body. For high temperature applications, fittings are identified with a red coloured O-ring and a red mark on the fitting.

***Important note:** The O-ring colour and identification must meet the application. O-ring in the fittings are not to be removed or changed.

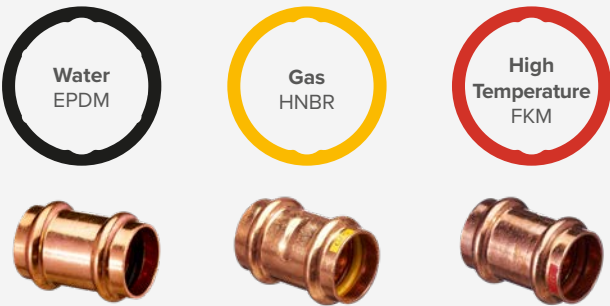

Section through >B< Press fitting

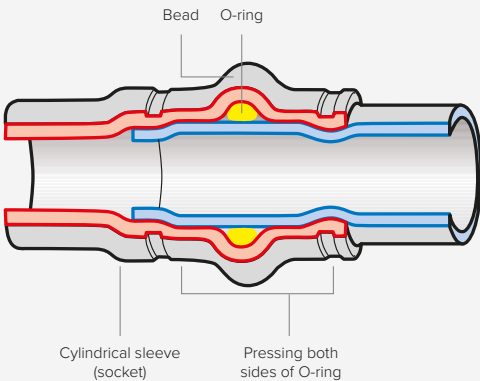

Pressing Indicator (PI) Feature

The unique pressing indicator is a specially designed O-ring. It has reduced sections that allows media past the sealing element of any unpressed connection, thereby providing a visible leakage point during the commissioning of the system.

Unpressed fittings are identified by pressurising the system with a pressure range of 100kPa to 500kPa for water (prior to the final pressure testing) and 2.2kPa to 300kPa for gas.

When the fitting is pressed, the O-ring material compresses, filling the gaps, creating a leak free joint.

Testing and Commissioning Installations

All fitting connections in a system should remain visible and accessible until leak and pressure tested.

WATER SYSTEMS

To ensure that all press joints have been successfully completed, a low pressure test is applied as follows:

- After flushing, fill the system with water and check for visible leaks.
- No leak. Apply a test pressure of between 100 and no more than 500kPa.
- No leak. Final testing should be conducted in accordance with AS/NZS 3500.

GAS SYSTEMS

If a joint has not been pressed, it will not hold pressure when tested at 2.2 to 300kPa.

Test as per the normal requirements of AS/NZS 5601.

Product Features

NEW >B< Press 360 Detect

All 15-50mm >B< Press water fittings are now fitted with our innovative 360 Detect unpressed fitting indicator.

Engineered with an improved leak path design and a more robust material, 360 Detect greatly improves the identification of unpressed fittings. Providing a positive leakage point at a larger flow rate through unpressed fittings during testing. Greatly increasing the ease with which installers can identify any unpressed fitting.

This innovation is your built in quality control to ensure unpressed joints are immediately identified - eliminating the risk of undetected connections and providing long term reassurance every fitting is secure.

Key product features

- Enhanced leak path design
- Greater flow rates through leak paths
- More robust o-ring material



Key benefits

- Built in quality control you can trust
- Easier identification of unpressed fittings
- Total reassurance every fitting is secured
- Reducing your risk when it matters most

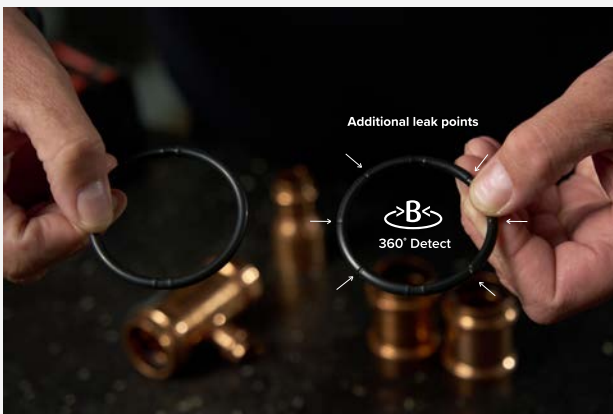

**Two stage pressure testing is still recommended per the standard

Technical Data

>B< Press and >B< Press XL are suitable for use with hard, half hard or annealed type A and B copper tube complying with AS1432.

Water Supply Systems

Application / Medium	Comments
Hot and cold potable water	Australian WaterMark approved. WaterMark certification for all plumbing products is restricted to 1400kPa at 95°C.
Fire services	Capable of the required test pressure of 1700kPa or 1.5 times the design pressure as specified by AS2419.1
Rainwater	
Pump circulated hot water systems	Compliant with EN12828
Chilled water and cooling systems	Water and water-glycol mixtures, mixing ratio max. 50/50
Steam	Low pressure steam equipment
Solar collectors	
Industrial and process water	Treated, softened, partially de-ionised water with a pH of 6.5 ≤ 9.5

Anti-Freeze / Corrosion Protection / Inhibitors

Application / Medium	Comments	
	Product	Manufacturer
Anti-freeze cooling concentration 50%	Antifrogen N	Clariant
	Antifrogen L	Clariant
	Antifrogen Sol (solar systems)	Clariant
	Ethylene Glycol (Ethan-1,2-diol)	Various
	Propylene Glycol (1,2-Propandiol)	Various
	Tyfoxit	Tyforop-Chemie
	Tyfocop	Tyforop-Chemie
	Antifrogen N	Clariant
	Antifrogen L	Clariant
	Antifrogen Sol (solar systems)	Clariant
	Ethylene Glycol (Ethan-1,2-diol)	Various
	Propylene Glycol (1,2-Propandiol)	Various
	Tyfoxit	Tyforop-Chemie
	Tyfocop	Tyforop-Chemie

✓ Indicates compatibility. (Consultation required for unlisted mediums)

***Note:** Installations need to comply to the relevant standards and local regulations. The maximum constant or standard operating pressure and temperature are shown. For testing or short spikes, higher pressure and temperature may be applicable.

****Note:** >B< Press Water and Gas valves have alternative applications data and pressure and temperature ratings. Please refer to pages 48-51 for more information.

	P (kPa)	T (°C)	>B< Press Water	>B< Press Gas	>B< Press HT
	1600	110	✓	✗	✓
	1600	110	✓	✗	✓
	1600	Ambient	✓	✗	✓
	1600	110	✓	✗	✓
	600	-10	✓	✗	
	≤100	120	✓	✗	✓
	1600	160	✗	✗	✓
	1600	110	✓	✗	✓

	P (kPa)	T (°C)	>B< Press Water	>B< Press Gas	>B< Press HT
	1600	-25 to 110	✓	✗	✗
			✓	✗	✗
			✓	✗	✗
			✓	✗	✗
			✓	✗	✗
			✓	✗	✗
			✓	✗	✗
	1600	-15 to 160	✗	✗	✓
			✗	✗	✓
			✗	✗	✓
			✗	✗	✓
			✗	✗	✓
			✗	✗	✓
			✗	✗	✓

Technical Data

Oils, Cooling Materials and Lubricants

Application / Medium	Comments
Engine oils and lubricants (Petroleum-based)	Consultation required
Engine oils (Synthetic based)	
Bio Diesel	
Heating oil, Diesel in acc. with EN590	

Gas

Application / Medium	Comments
Natural Gas Liquid Gas Propane Butane Methane	The scope of AS5601 for all gas systems is restricted to 200kPa.
Argon	For welding
Forming Gas, Dry / Welding Inert Gas	Ar+CO ² (e.g. Cargon)
Vacuum	
Carbon Dioxide (dry gas)	
Carbon Dioxide (wet gas)	
Nitrogen (gas)	
Helium	May leak at <0.001cm ³ /min
Neon	
Xenon	
Synthetic air	
Krypton	
Oxygen	
Acetylene	
Hydrogen	May leak at <0.001cm ³ /min
Carbon Monoxide	XL not compatible
Compressed air	Oil concentration <25mg/m ³ Oil concentration >25mg/m ³

Special Media

Application / Medium	Comments
Acetone (liquid)	
Condensate	From gas condenser boiler or steam
Ethanol	
Urea	
Methanol	
Sodium Hydroxide	
Ammonia	

	P (kPa)	T (°C)	>B< Press Water	>B< Press Gas	>B< Press HT
	1000	70	✗	✓	✗
			✗	✗	✓
	Not compatible				
	500	-20 to 40	✗	✓	✓

	P (kPa)	T (°C)	>B< Press Water	>B< Press Gas	>B< Press HT
	1000	-20 to 70	✗	✓	✗
	1600	70	✓	✓	✓
	1600	70	✓	✓	✓
	-80	Ambient	✓	✓	✓
	1600	Ambient	✓	✓	✓
	Not compatible				
	1600	70	✓	✓	✓
	1600	70	✓	✓	✓
	1600	70	✓	✓	✓
	1600	70	✓	✓	✓
	1600	70	✓	✓	✓
	1600	70	✓	✓	✓
	1000	60	✓	✓	✓
	Not compatible				
	500	70	✓	✓	✓
	1600	70	✓	✓	✓
	1600	70	✓	✓	✓
	1600	70	✗	✓	✓

	P (kPa)	T (°C)	>B< Press Water	>B< Press Gas	>B< Press HT
	500	-10 to 40	✓	✗	✗
	1600	110	✓	✗	✓
	1600	25	✓	✗	✓
	Not compatible				
	Not compatible				
	Not compatible				
	Not compatible				

Installation Instructions

To install >B< Press, a Rothenberger Romax mechanical tool with compatible sized jaw to fit each size fitting is required. When pressure is exerted through the press tool, a permanent joint is made and the fitting cannot be disassembled or re-used.



Step 1 – Cut the pipe

- It is important to ensure that the pipe is cut completely square.
- Tube ends should be clean and free from scratches not less than the socket length.

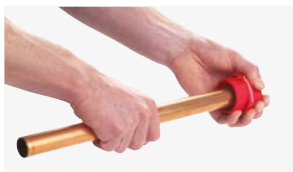

Step 2 – Remove burrs

- Make sure that the internal and external tube end is free from burrs or sharp edges by using a deburring tool in one direction clockwise to prevent damage to the O-ring.
- Then wipe the tube end clean to avoid damaging the O-ring on tube insertion.



Step 3 – Ensure the O-ring is seated and lubricated

- Before inserting the copper tube, ensure that the O-ring is seated correctly, free from damage and lubricated.
- If O-ring is dry, a small amount of water can be used to provide lubrication.



Step 4 – Mark insertion depth

- The tube must be fully inserted into the fitting until it reaches the tube stop.
- Mark insertion depth to ensure that any tube movement is detected, which is especially important if the joints are to be pressed at a later time.

Note: As repair couplings do not have a tube stop, both ends of the tube must meet in the middle of the fitting.



Alternatively, use depth gauge

- Insert tube into correct socket in depth gauge.
- Check window to see the tube is fully inserted.
- Mark the insertion depth on the tube.



Step 6 – Complete the joint with the compression tool

- Ensure that the correct size jaw for the fitting is inserted into the tool. The jaws must be placed square on the fitting.
- Press and hold the trigger/button to begin the compression cycle of the tool. The tool automatically stops when the cycle has been completed.
- Release the button and then remove the jaws from around the fitting. (For further information, refer to complete Romax instructions.)

Note: Do not crimp any >B< Press fitting more than once. You must use an approved tool to maintain your warranty.



Step 5 – Ensure pipe is inserted up to the tube stop

- To assemble the joint, the tube must be inserted into the fitting up to the tube stop. The pressing operation should only be undertaken when the tube reaches the tube stop. Rotate the tube slightly to ease the tube over the O-ring.

IMPORTANT

IT IS IMPORTANT TO KEEP THE FITTING FREE OF ANY DUST OR DIRT AND TO ENSURE THE O-RING STAYS LUBRICATED AND PROTECTED FROM DAMAGE. SELECT THE CORRECT SIZE OF TUBE AND FITTING FOR THE JOB. ENSURE THAT BOTH ARE CLEAN AND FREE FROM DAMAGE AND IMPERFECTIONS.



STRAIGHT CONNECTOR

Product Code	Size (D1)	L	Z
406728	15mm	39	3
406729	18mm	49	3
406730	20mm	47	3
406731	25mm	49	3
406732	32mm	53	3
406733	40mm	64	2
406734	50mm	80	2

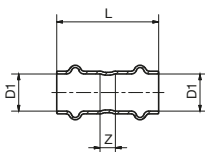

REPAIR COUPLER

Product Code	Size (D1)	L
406735	15mm	39
406736	18mm	49
406737	20mm	47
406738	25mm	49
406739	32mm	53
406740	40mm	64
406741	50mm	80

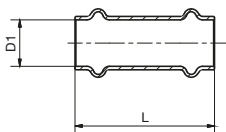

REDUCING COUPLING

Product Code	Size (D1 x D2)	L	Z
406900	18 x 15mm	43	2
406707	20 x 15mm	47	7
406901	20 x 18mm	48	4
406708	25 x 15mm	54	13
406709	25 x 20mm	52	7
406710	32 x 20mm	59	13.5
406711	32 x 25mm	55	7
406712	40 x 25mm	67	13
406713	40 x 32mm	62	6
406714	50 x 25mm	86	24
406715	50 x 32mm	83	19
406716	50 x 40mm	83	13

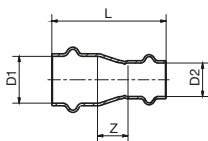

FITTING REDUCER

Product Code	Size (D1 x D2)	L	Z
406719	20 x 15mm	50	32
406720	25 x 15mm	55	37
406721	25 x 20mm	54	32.5
406722	32 x 20mm	62	40
406723	32 x 25mm	57	34
406724	40 x 25mm	68	45.5
406725	40 x 32mm	65	40
406726	50 x 32mm	84	59
406727	50 x 40mm	86	55

***Note:** Reduces >B< Press Fitting, not to be soldered.

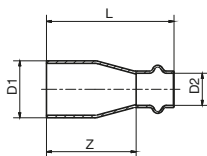



MALE COUPLING

Product Code	Size (D1 x R)	L	Z	S
406902	15mm x 1/2" BSP	43	25	22
406903	15mm x 3/4" BSP	47	29	27
406904	18mm x 1/2" BSP	46	23	24
406905	20mm x 1/2" BSP	48	26	27
406906	20mm x 3/4" BSP	48	26	27
406907	25mm x 3/4" BSP	50	27	27
406908	25mm x 1" BSP	54	31	34
406909	32mm x 1 1/4" BSP	59	34	43
406910	40mm x 1 1/2" BSP	67	36	50
406911	50mm x 2" BSP	80	41	62

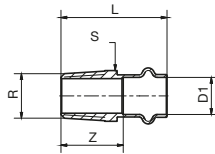

FEMALE COUPLING

Product Code	Size (D1 x Rp)	L	Z	S
406912	15mm x 1/2" BSP	41	8	26
406913	18mm x 1/2" BSP	44	6	26
406914	20mm x 3/4" BSP	45	7	31
406915	25mm x 1" BSP	50	8	39
406916	32mm x 1 1/4" BSP	56	10	48
406917	40mm x 1 1/2" BSP	63	11	55
406918	50mm x 2" BSP	76	11	70

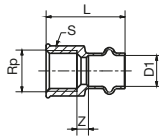

FLANGE ADAPTOR (TABLE E)

Product Code	Size (D1)	L	Z	K	D2	D3
406898	40mm	79	48	98	14	135
406899	50mm	85	46	114	18	150

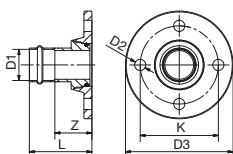

ELBOW - 90 DEGREE

Product Code	Size (D1)	L	Z
406648	15mm	32	14
406649	18mm	38	15
406650	20mm	43	21
406651	25mm	53	30
406652	32mm	60	35
406653	40mm	76	45
406654	50mm	100	61

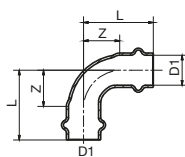

ELBOW M&F - 90 DEGREE

Product Code	Size (D1)	L1	Z	L2
406642	15mm	32	14	34
406643	20mm	43	21	46
406644	25mm	53	30	55
406645	32mm	60	35	62
406646	40mm	76	45	78
406647	50mm	100	61	102

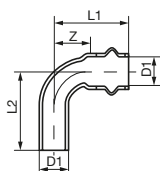



ELBOW - 45 DEGREE

Product Code	Size (D1)	L	Z
406661	15mm	24	6.5
406662	20mm	31	9.5
406663	25mm	35	12.5
406664	32mm	39	14.5
406665	40mm	50	19.5
406666	50mm	64	25.5

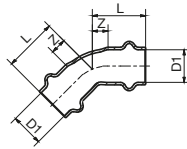

ELBOW M&F - 45 DEGREE

Product Code	Size (D1)	L1	Z	L2
406657	25mm	35	12	37
406658	32mm	39	14	41
406659	40mm	50	19	52
406660	50mm	64	25	66

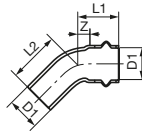

THREADED ELBOW - MALE 90 DEGREE

Product Code	Size (D1 x R)	L1	Z	L2	S
406895	15mm x 1/2" BSP	32	14	42	22
406897	20mm x 3/4" BSP	43	21	51	27
406896	15mm x 3/4" BSP	32.5	14.5	46	27

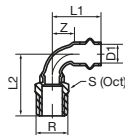

THREADED ELBOW - FEMALE 90 DEGREE

Product Code	Size (D1 x Rp)	L1	Z	L2	L3	S
406893	15mm x 1/2" BSP	32	14	25	15	22
406894	20mm x 3/4" BSP	43	21	33	16	27

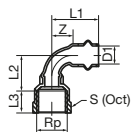

TEE

Product Code	Size (D1 x D2 x D3)	L1	L2	L3	Z1	Z2	Z3
406673	15mm	33	33	28	15	15	10
406674	18mm	40	40	34	17	17	11
406678	20mm	42	42	36	20	20	14
406681	25mm	47	47	40	24	24	17
406685	32mm	49	49	46	24	24	21
406689	40mm	58	58	58	27	27	27
406692	50mm	73	73	73	34	34	34

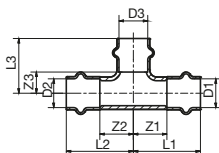



REDUCING TEE

Product Code	Size (D1 x D2 x D3)	L1	L2	L3	Z1	Z2	Z3
406676	20 x 20 x 15mm	39	39	31.5	17	17	14
406677	20 x 15 x 20mm	42	40	36	20	22	14
406675	20 x 15 x 15mm	39	40	32	17	22	14
406679	25 x 25 x 15mm	38	38	35	15	15	17
406680	25 x 25 x 20mm	42	42	39	19	19	17
406682	32 x 32 x 15mm	39	39	39	14	14	21
406683	32 x 32 x 20mm	43	43	44	18	18	22
406684	32 x 32 x 25mm	46	46	44	21	21	21
406686	40 x 40 x 20mm	49	49	47	18	18	25
406687	40 x 40 x 25mm	50	50	48	19	19	25
406688	40 x 40 x 32mm	53	53	52	22	22	27
406690	50 x 50 x 25mm	59	59	56	20	20	33
406691	50 x 50 x 40mm	66	66	64	27	27	33

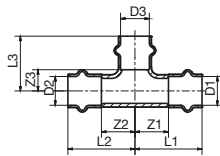

FEMALE ADAPTOR TEE

Product Code	Size (D1 x D1 x R1)	L	Z	L1	Z1
406694	15 x 15mm x 1/4"	33	15.5	29.7	18.7
406695	15 x 15mm x 3/8"	33	15.5	31	19.7
406939	15 x 15mm x 1/2"	33	15.5	36.5	21.5
406940	20 x 20mm x 1/4"	39	17.5	33.7	22.7
406941	25 x 25mm x 1/4"	38	16	36.7	25.7
406701	32 x 32mm x 1/4"	39	14	40.7	29.7

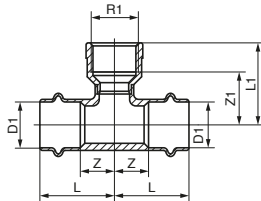

VALVE ADAPTOR

Product Code	Size (D1 x R1)	L	Z
406635	15mm x 3/4"	45	22.6
405158	20mm x 1"	52	26
406638	25mm x 1 1/2"	55	27
406640	32mm x 1 1/2"	61	31
406634	15mm x 1/2"	41	19.6
406636	20mm x 3/4"	56.5	30.5
406637	25mm x 1"	60.5	33.5
406639	32mm x 1 1/4"	66.5	37
406641	40mm x 1 1/2"	80.7	44.5

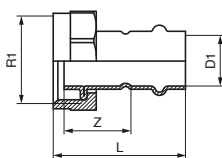

END CAP

Product Code	Size (D1)	L	Z
406742	15mm	20	18
406743	18mm	22	20
406744	20mm	24	22
406745	25mm	25	23
406746	32mm	27	25
406747	40mm	33	31
406748	50mm	41	39

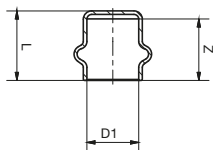



WALL PLATE ELBOW - FEMALE

Product Code	Size (D1 x Rp)	L1	Z	L2	L3	L4
406931	15mm x 1/2" BSP	42	24	24	15	18
406932	20mm x 3/4" BSP	47	25	27	16	24

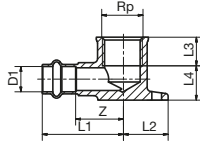

WALL PLATE ELBOW - MALE

Product Code	Size (D1 x Rp)	L1	Z	L2	L3	L4
406933	15mm x 1/2" BSP	22	24	30	52	42

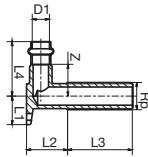

WALL PLATE ELBOW - MALE LONG THREADED

Product Code	Size (D1 x Rp)	L1	Z	L2	L3	L4
406934	15mm x 1/2" BSP	22	25	30	150	42
406935	20mm x 3/4" BSP	22	26	40	150	47

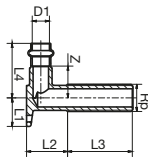

FEMALE UNION

Product Code	Size (D1 x Rp)	L	Z	S1	S2
406919	15mm x 1/2" BSP	55	22	30	28
406920	20mm x 3/4" BSP	68	30	37	34
406921	25mm x 1" BSP	64	22	46	42
406922	32mm x 1 1/4" BSP	83	38	53	50
406923	40mm x 1 1/2" BSP	94	42	65	57
406924	50mm x 2" BSP	106	42	83	72

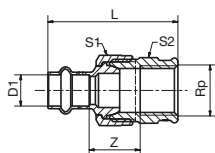

MALE UNION

Product Code	Size (D1 x R)	L	Z	S1	S2
406925	15mm x 1/2" BSP	63	46	29	27
406926	20mm x 3/4" BSP	77	55	37	34
406927	25mm x 1" BSP	84	61	46	43
406928	32mm x 1 1/4" BSP	93	68	53	50
406929	40mm x 1 1/2" BSP	106	75	65.5	64
406930	50mm x 2" BSP	124	85	83	80

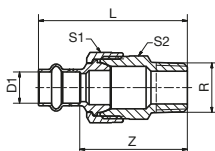

TAP CONNECTOR - STRAIGHT

Product Code	Size	L	Z	S
406717	15mm x 1/2" BSP	42	27	27
406718	20mm x 3/4" BSP	52	33	36

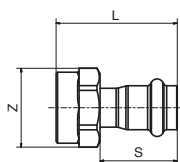



TAP CONNECTOR - BENT

Product Code	Size	L	Z	S
406655	15mm x 1/2" BSP	45	35	24
406656	20mm x 3/4" BSP	55	46	31

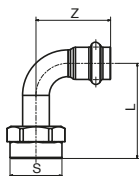

AUSPEX ADAPTOR

Product Code	Size (ØA x ØB)	C	D	E
1544580	16 x 15mm	11	17.5	37.5
1544581	20 x 20mm	11	21.5	44
1544582	25 x 25mm	12	22.5	49

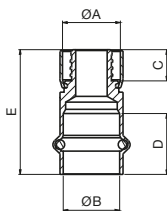

REHAU ADAPTOR

Product Code	Size (D1 x D2)	L	Z
405111	15 x 16mm	42	24
405112	20 x 20mm	54	32
405117	25 x 25mm	64	41

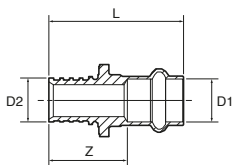

CROSS OVER BEND

Product Code	Size (D1)	L	Z	H1
406670	15mm	127	94	22
406671	20mm	143	101	20
406672	25mm	164	116	22

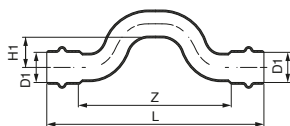

RETURN BEND

Product Code	Size (D1)	L	Z	L1
406667	15mm	37	20	36
406668	20mm	56	34	63
406669	25mm	60	38	68

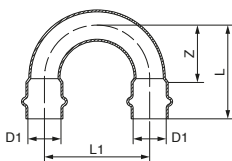



STRAIGHT CONNECTOR

Product Code	Size (D1)	L	Z
404697	15mm	39	3
404698	20mm	47	3
404699	25mm	49	3
404700	32mm	53	3
404701	40mm	64	2
404702	50mm	80	2

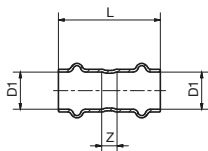

REPAIR COUPLER

Product Code	Size (D1)	L
404757	15mm	39
404758	20mm	47
404759	25mm	49
404760	32mm	53
404761	40mm	64
404762	50mm	80

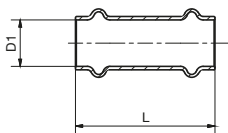

REDUCING COUPLING

Product Code	Size (D1 x D2)	L	Z
404728	20 x 15mm	47	7
404729	25 x 15mm	54	13
404730	25 x 20mm	52	7
404731	32 x 25mm	55	7
404732	40 x 25mm	67	13
404733	40 x 32mm	62	6
404734	50 x 25mm	86	24
404735	50 x 32mm	83	19
404736	50 x 40mm	83	13

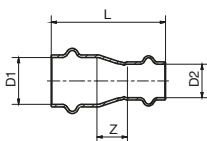

FITTING REDUCER

Product Code	Size (D1 x D2)	L	Z
404748	20 x 15mm	50	32
404749	25 x 15mm	55	37
404750	25 x 20mm	54	32.5
404751	32 x 20mm	62	40
404752	32 x 25mm	57	34
404753	40 x 25mm	68	45.5
404754	40 x 32mm	65	40
404755	50 x 32mm	84	59
404756	50 x 40mm	86	55

***Note:** Reduces >B< Press Fitting, not to be soldered.

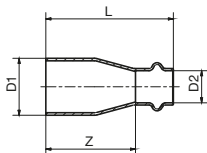



MALE COUPLING

Product Code	Size (D1 x R)	L	Z	S
406853	15mm x 1/2" BSP	43	25	22
406854	15mm x 3/4" BSP	47	29	27
406855	20mm x 1/2" BSP	48	26	27
406856	20mm x 3/4" BSP	48	26	27
406857	25mm x 3/4" BSP	50	27	27
406858	25mm x 1" BSP	54	31	34
406859	32mm x 1 1/4" BSP	59	34	43
406860	40mm x 1 1/2" BSP	67	36	50
406861	50mm x 2" BSP	80	41	62

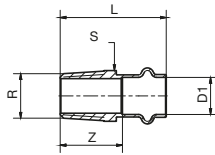

FEMALE COUPLING

Product Code	Size (D1 x Rp)	L	Z	S
406862	15mm x 1/2" BSP	41	8	26
406863	20mm x 3/4" BSP	45	7	31
406864	25mm x 1" BSP	50	8	39
406865	32mm x 1 1/4" BSP	56	10	48
406866	40mm x 1 1/2" BSP	63	10	55
406867	50mm x 2" BSP	76	11	70

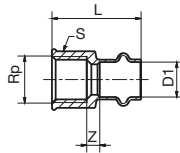

FLANGE ADAPTOR (TABLE E)

Product Code	Size (D1)	L	Z	K	D2	D3
406793	40mm	79	48	98	14	135
406794	50mm	85	46	114	18	150

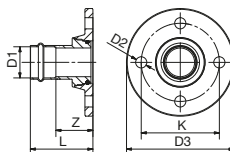

ELBOW - 90 DEGREE

Product Code	Size (D1)	L	Z
404703	15mm	32	14
404704	20mm	43	21
404705	25mm	53	30
404706	32mm	60	35
404707	40mm	76	45
404708	50mm	100	61

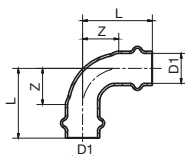

ELBOW M&F - 90 DEGREE

Product Code	Size (D1)	L1	Z	L2
404917	15mm	32	14	34
404918	20mm	43	21	46
404919	25mm	53	30	55
404920	32mm	60	35	62
404921	40mm	76	45	78
404922	50mm	100	61	102

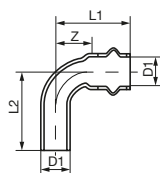

ELBOW - 45 DEGREE

Product Code	Size (D1)	L	Z
405172	15mm	23.5	6.5
405173	20mm	31	9.5
404769	25mm	35	12.5
404770	32mm	39	14.5
404771	40mm	50	19.5
404772	50mm	64	25.5

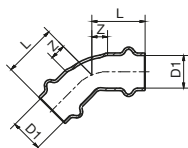



ELBOW M&F - 45 DEGREE

Product Code	Size (D1)	L1	Z	L2
404910	25mm	35	12	37
404911	32mm	39	14	41
404912	40mm	50	19	52
404913	50mm	64	25	66

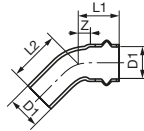

ELBOW - MALE 90 DEGREE

Product Code	Size (D1 x R)	L1	Z	L2	S
406851	15mm x 1/2" BSP	32	14	42	22
406852	20mm x 3/4" BSP	43	21	51	27

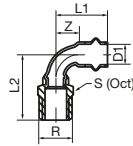

ELBOW - FEMALE 90 DEGREE

Product Code	Size (D1 x Rp)	L1	Z	L2	L3	S
406849	15mm x 1/2" BSP	32	14	25	15	22
406850	20mm x 3/4" BSP	43	21	33	16	27

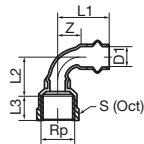

TEE

Product Code	Size (D1 x D2 x D3)	L1	L2	L3	Z1	Z2	Z3
404709	15mm	33	33	28	15	15	10
404710	20mm	42	42	36	20	20	14
404711	25mm	47	47	40	24	24	17
404712	32mm	49	49	46	24	24	21
404713	40mm	58	58	58	27	27	27
404714	50mm	73	73	73	34	34	34

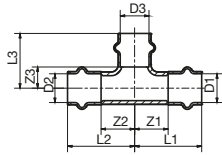

REDUCING TEE

Product Code	Size (D1 x D2 x D3)	L1	L2	L3	Z1	Z2	Z3
404715	20 x 20 x 15mm	39	39	31.5	17	17	14
404726	20 x 15 x 20mm	42	40	36	20	22	14
404727	20 x 15 x 15mm	39	40	32	17	22	14
404716	25 x 25 x 15mm	38	38	35	15	15	17
404717	25 x 25 x 20mm	42	42	39	19	19	17
404718	32 x 32 x 15mm	39	39	39	14	14	21
404719	32 x 32 x 20mm	43	43	44	18	18	22
404720	32 x 32 x 25mm	46	46	44	21	21	21
404721	40 x 40 x 20mm	49	49	47	18	18	25
404722	40 x 40 x 25mm	50	50	48	19	19	25
404723	40 x 40 x 32mm	53	53	52	22	22	27
404724	50 x 50 x 25mm	59	59	56	20	20	33
404725	50 x 50 x 40mm	66	66	64	27	27	33

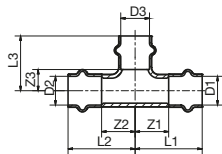



END CAP

Product Code	Size (D1)	L	Z
404787	15mm	20	18
404788	20mm	24	22
404789	25mm	25	23
404790	32mm	27	25
404791	40mm	33	31
404792	50mm	41	39

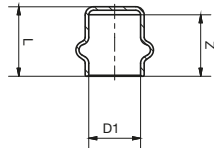

WALL PLATE ELBOW - MALE

Product Code	Size	Z	L2	L3	L4
406882	15mm x 1/2" BSP	24	30	52	42

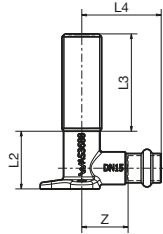

*Note: As per AS/NZS 5601.1 Gas Installations

A brass external parallel thread to a brass internal parallel thread may be used, provided that the joint is welded or a suitable permanent quick-setting thread compound is used and a means of disconnection is provided immediately downstream. Wherever possible, the fitting should be secured against disturbance.

WALL PLATE ELBOW - FEMALE

Product Code	Size (D1 x Rp)	L1	Z	L2	L3	L4
406880	15mm x 1/2" BSP	42	24	24	15	18
406881	20mm x 3/4" BSP	47	25	27	16	24

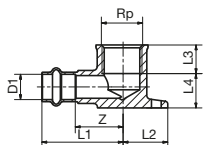

FEMALE UNION

Product Code	Size (D1 x Rp)	L	Z	S1	S2
406868	15mm x 1/2" BSP	55	22	30	28
406869	20mm x 3/4" BSP	68	30	37	34
406870	25mm x 1" BSP	65	23	46	42
406871	32mm x 1 1/4" BSP	83	38	53	50
406872	40mm x 1 1/2" BSP	94	42	65	57
406873	50mm x 2" BSP	106	42	83	72

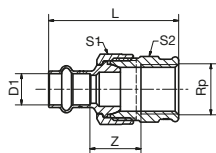



MALE UNION

Product Code	Size (D1 x R)	L	Z	S1	S2
406874	15mm x 1/2" BSP	63	46	29	27
406875	20mm x 3/4" BSP	77	55	37	34
406876	25mm x 1" BSP	84	61	46	43
406877	32mm x 1 1/4" BSP	93	68	53	50
406878	40mm x 1 1/2" BSP	106	75	65.5	64
406879	50mm x 2" BSP	124	85	83	80

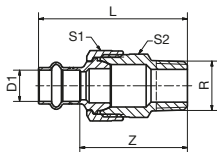

REHAU ADAPTOR

Product Code	Size (D1 x D2)	L	Z
405113	15 x 16mm	42	24
405114	20 x 20mm	54	32
405116	25 x 25mm	64	41

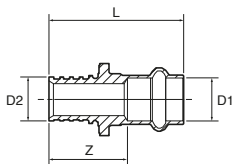

>B< PRESS DEPTH GAUGE

Product Code

406067



INSTALLATION TAG

Product Code Size

2130197 90 x 55mm



>B< LUBRICANT OIL

Product Code Size

406047 100ml





STRAIGHT CONNECTOR

Product Code	Size (D1)	L	Z
404926	15mm	39	3
404927	20mm	47	3
404928	25mm	49	3

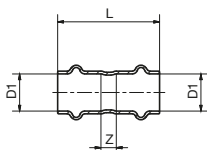

REDUCING COUPLING

Product Code	Size (D1 x D2)	L	Z
405133	20 x 15mm	47	7
404935	25 x 15mm	54	13
404936	25 x 20mm	52	7

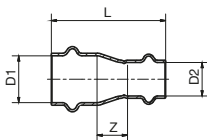

MALE COUPLING

Product Code	Size (D1 x R)	L	Z	S
406887	15mm x 1/2" BSP	43	25	22
406888	20mm x 3/4" BSP	48	26	27
406889	25mm x 1" BSP	54	31	34

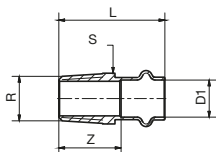

FEMALE COUPLING

Product Code	Size (D1 x Rp)	L	Z	S
406890	15mm x 1/2" BSP	41	8	26
406891	20mm x 3/4" BSP	45	7	31
406892	25mm x 1" BSP	50	8	39

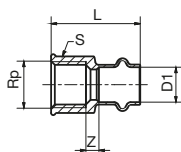

ELBOW - 90 DEGREE

Product Code	Size (D1)	L	Z
404929	15mm	32	14
404930	20mm	43	21
404931	25mm	53	30

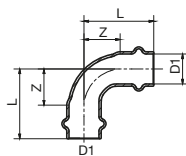

TEE

Product Code	Size (D1 x D2 x D3)	L1	L2	L3	Z1	Z2	Z3
404932	15mm	33	33	28	15	15	10
404933	20mm	42	42	36	20	20	14
404934	25mm	47	47	40	24	24	17

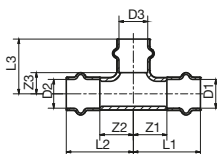

***Note:** When installing High Temperature fittings for solar applications, the fittings should not be left in 'dry' installations as the temperature can exceed the performance of the fittings. Solar panels/tubes should be covered during installation until such time as the system is commissioned with water.

> B < Press Valves





Technical Data

>B< Press Quarter Turn Ball Valves are suitable for use with hard, half hard or annealed type A and B copper tube complying with AS1432.

PRESSURE AND TEMPERATURE RATING

Valve series	Size (DN)	PN
Water (blue handle)	15 to 50	16
Gas (yellow handle)	15 to 50	10

Valves should only be installed in a system where the normal pressure and temperature does not exceed the stated rating of the valve. The maximum allowable pressure in valves as specified in standards is for non-shock conditions. Systems which create water hammer or impact should be avoided.

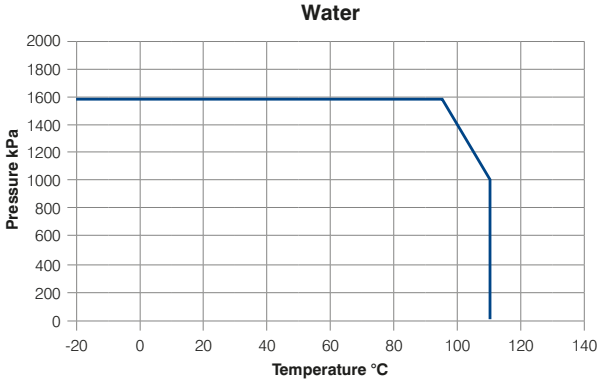

Water Supply Systems

Application / Medium	Comments
Hot and cold potable water	Australian WaterMark approved. WaterMark certification for all plumbing products is restricted to 1400kPa at 95°C.
Pump circulated hot water systems	Capable of the required test pressure of 1700kPa or 1.5 times the design pressure as specified by AS2419.1
Chilled water	
Steam	

Maximum Operating Parameters

1600 kPa from -20° to 95°C

1050 kPa from -20° to 100°C

Where system testing will subject a valve to pressures in excess of the working pressure rating, such testing should be within the “shell test pressure” for the body, to a maximum of 1.5 times the PN rating given for the valve. Any such test should be carried out with the valve in the fully open condition.

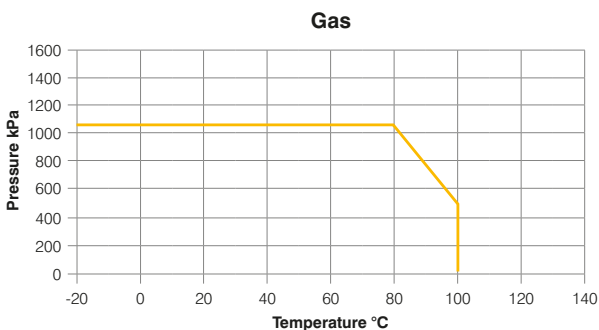

✓ Indicates compatibility. (Consultation required for unlisted mediums)

***Note:** Installations need to comply to the relevant standards and local regulations.

	P (kPa)	T (°C)	>B< Press Water Ball Valves	>B< Press Gas Ball Valves
	1600	95	✓	✗
	1600	95	✓	✗
	1000	5	✓	✗
Not compatible				

Technical Data

Anti-Freeze / Corrosion Protection / Inhibitors

Application / Medium	Comments	
	Product	Manufacturer
Anti-freeze cooling concentration 50%	Antifrogen N	Clariant
	Antifrogen L	Clariant
	Antifrogen Sol (solar systems)	Clariant
	Ethylene Glycol (Ethan -1, 2-diol)	Various
	Propylene Glycol (1,2-Propandiol)	Various
	Tyfoxit	Tyforop-Chemie
	Tyfocop	Tyforop-Chemie

Oils, cooling materials and lubricants

Application / Medium	Comments
Engine oils and Lubricants (Petroleum-based)	Consultation required
Heating oil, Diesel in acc. with EN590	

Gas

Application / Medium	Comments
Natural Gas Liquid gas Propane Butane Methane	The scope of AS5601 for all gas systems is restricted to 200kPa
Nitrogen	
Oxygen	Not compatible
Compressed Air	Oil Concentration <25mg/m3
	Oil Concentration >25mg/m3

	P (kPa)	T (°C)	>B< Press Water Ball Valves	>B< Press Gas Ball Valves
	1600	-20 to 95	✓	✗
			✓	✗
			✓	✗
			✓	✗
			✓	✗
			✓	✗
			✓	✗

	P (kPa)	T (°C)	>B< Press Water Ball Valves	>B< Press Gas Ball Valves
	1000	100	✗	✓
	500	-20 to 40	✗	✓

	P (kPa)	T (°C)	>B< Press Water Ball Valves	>B< Press Gas Ball Valves
	1050	-20 to 100	✗	✓
	1050	100	✗	✓
	1050	100	✓	✓
	1050	100	✗	✓



LEVER BALL VALVES

Product Code	Size	A	B	C
405361	15mm	74	50	103
405362	20mm	88.5	61	125
405363	25mm	94.5	65	125
405364	32mm	113	72	125
405365	40mm	136.5	91	182
405366	50mm	169	99	182

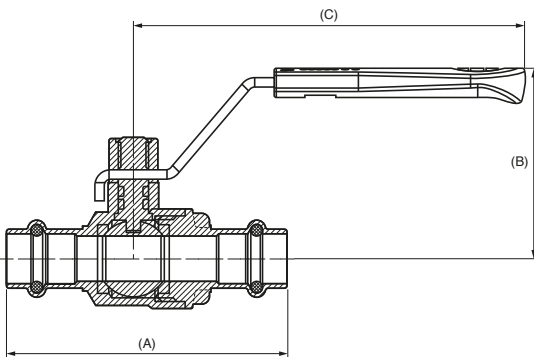

T-HANDLE BALL VALVES

Product Code	Size	A	B
405371	15mm	74	38.5
405372	20mm	88.5	43.7

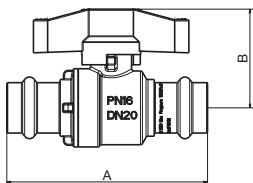

FEMALE T-HANDLE BALL VALVES

Product Code	Size	A	B
405369	15mm x 1/2" BSP	66	38.5
405370	20mm x 3/4" BSP	77	43.7

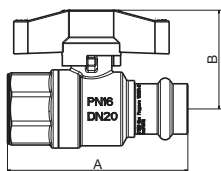

MALE T-HANDLE BALL VALVES

Product Code	Size	A	B
405367	15mm x 1/2" BSP	69.5	38.5
405368	20mm x 3/4" BSP	82	43.7

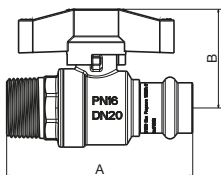



LEVER BALL VALVES

Product Code	Size	A	B	C
1005706	15mm	74	50	103
1005707	20mm	88.5	61	125
1005708	25mm	94.5	65	125
1005709	32mm	113	72	125
1005710	40mm	136.5	91	182
1005711	50mm	169	99	182

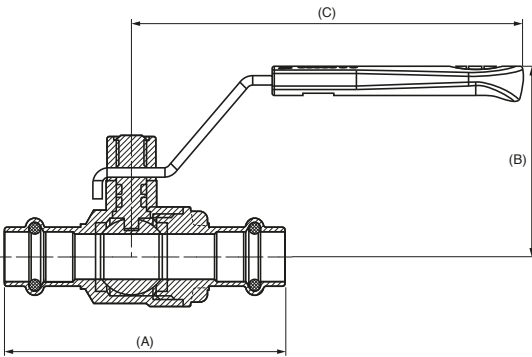

T-HANDLE BALL VALVES

Product Code	Size	A	B
1005750	15mm	74	38.5
1005751	20mm	88.5	43.7

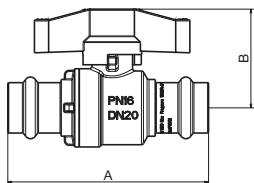

FEMALE T-HANDLE BALL VALVES

Product Code	Size	A	B
1005754	15mm x 1/2" BSP	66	38.5
1005755	20mm x 3/4" BSP	77	43.7

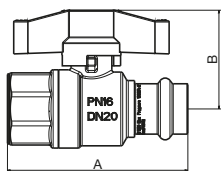

MALE T-HANDLE BALL VALVES

Product Code	Size	A	B
1005762	15mm x 1/2" BSP	69.5	38.5
1005763	20mm x 3/4" BSP	82	43.7

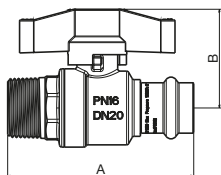

> XL Fittings 65-100mm <





Section through >B< Press XL fitting

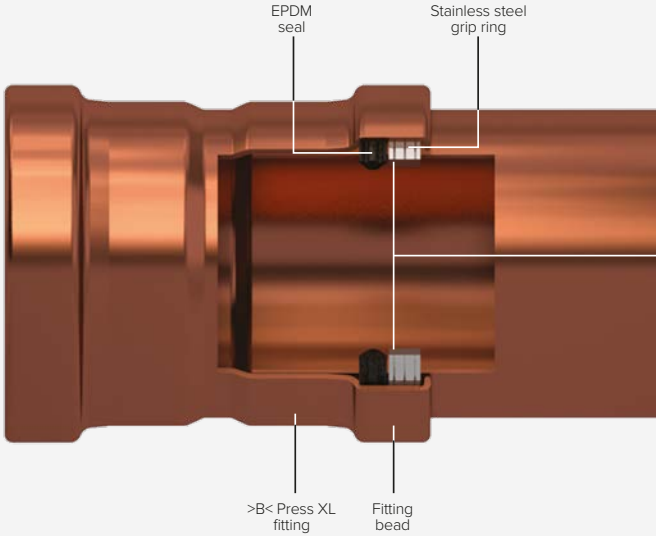

Product Features

>B< Press XL has only two internal parts, the grip ring and the seal. Both parts have an internal diameter larger than the tube, which allows for easy tube insertion and pre-press leak indication.



Stainless Steel Grip Ring

The full circumference grip ring ensures all round equal grip on the tube and an even seal compression between the tube and fitting after pressing.



Copper
tube

The stainless steel grip ring pressed on top, forcing the grip ring teeth against the tube, making a high strength connection.



Triple Point Seal

The triple point seal on the pressed fitting body counters any pressing distortion and gives greater seal contact area on the tube. The seal is self setting to ensure correct functioning, security and longevity. The seal is also not easily displaced by tube insertion.

Installation Instructions

To install >B< Press XL, a Rothenberger Romax 3000/4000 mechanical tool with actuator and compatible sized jaw to fit each size fitting is required. When pressure is exerted through the press tool, a permanent joint is made and the fitting cannot be disassembled or re-used.



Step 1 – Cut the pipe

- We recommend you use a Rothenberger pipe cutter. It is important to ensure that the pipe is cut completely square.
- Tube ends should be clean and free from scratches not less than the socket length.



Step 2 – Remove burrs

- Make sure that the internal and external tube end is free from burrs or sharp edges by using a file or deburring tool in one direction clockwise.
- Then wipe the tube end clean to avoid damaging the seal on tube insertion.



Step 3 – Inspect the fitting

- Keep fittings in original wrapping until required.
- Make sure the fitting is protected against dirt and contamination before use.
- Make sure the fitting and the bag are marked up for the correct application (Water or Gas).
- Select the correct size fittings for the tube.
- Before inserting the tube, check seal and grip ring for correct placement.



Step 4 – Insert the tube

- The tube must be fully inserted into the fitting until it reaches the tube stop in order to make a perfect joint.
- Marking insertion depth will ensure that any tube movement is detected, which is especially important if the joints are to be pressed at a later time. The depth marking must be visible on the pressed fitting.

Tube size Insertion depth

DN65	43 mm
DN80	50 mm
DN100	60 mm



Step 5 – Fit the pressing ring

- Using the appropriate size pressing ring, open the pressing ring, locate on the fitting bead and close the pressing ring.



Step 6 – Engage the actuator and check insertion depth

- With the actuator fitted in the press tool, open the actuator and locate the actuator into the aperture of the pressing ring.
- Check for any tube movement prior to pressing.



Step 7 – Press the joint

- Press and hold the trigger/button to begin the compression cycle of the tool. The tool automatically stops when the cycle has been completed.
- Release the button and then remove the jaws from around the fitting.



Step 8 – Joint completion

- Remove the actuator from the press ring, remove the press ring from the tube and remove the label to indicate the joint is pressed and complete.

Note: You must use an approved tool to maintain your warranty.

IMPORTANT

IT IS IMPORTANT TO KEEP THE FITTING FREE OF ANY DUST OR DIRT AND TO ENSURE THE SEAL STAYS LUBRICATED AND PROTECTED FROM DAMAGE. SELECT THE CORRECT SIZE OF TUBE AND FITTING FOR THE JOB. ENSURE THAT BOTH ARE CLEAN AND FREE FROM DAMAGE AND IMPERFECTIONS.



STRAIGHT CONNECTOR

Product Code	Size (D1)	L	Z
404793	65mm	92	4
404794	80mm	106	4
404795	100mm	126	4

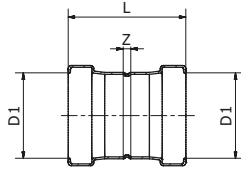

REPAIR COUPLER

Product Code	Size (D1)	L
405121	65mm	110
405122	80mm	125
405123	100mm	144

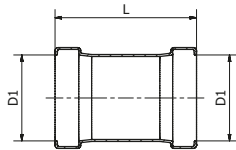

REDUCING COUPLING

Product Code	Size (D1 x D2)	L	Z
404822	65 x 32mm	101	30
404823	65 x 40mm	100	25
404824	65 x 50mm	100	24
404825	80 x 40mm	117	40
404826	80 x 50mm	119	36
404827	80 x 65mm	119	25
404828	100 x 50mm	142	43
404829	100 x 65mm	134	31
404830	100 x 80mm	135	25

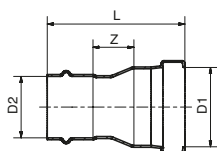

FITTING REDUCER

Product Code	Size (D1 x D2)	L	Z
404831	65 x 40mm	106	75
404832	65 x 50mm	103	64
404833	80 x 50mm	122	83
404834	80 x 65mm	131	87
404835	100 x 50mm	145	106
404836	100 x 65mm	139	96
404837	100 x 80mm	136	86

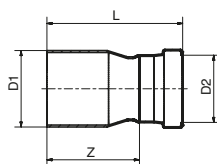



MALE COUPLING

Product Code	Size (D1 x R)	L	Z	S
404943	65mm x 2 1/2"	121	78	85
404944	80mm x 3"	126	78	95
404945	100mm x 4"	150	91	125

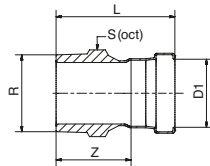

FEMALE COUPLING

Product Code	Size (D1 x Rp)	L	Z	S
404946	65mm x 2 1/2"	112	31	85
404947	80mm x 3"	114	33	95
404948	100mm x 4"	138	37	125

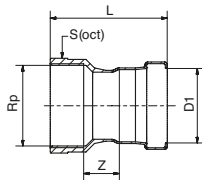

ELBOW - 90 DEGREE

Product Code	Size (D1 x D2)	L	Z
404796	65mm	126	82
404797	80mm	150	98
404798	100mm	192	132

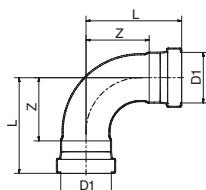

ELBOW M&F - 90 DEGREE

Product Code	Size (D1)	L	Z	L2
404857	65mm	132	88	146
404858	80mm	150	98	148
404859	100mm	192	132	212

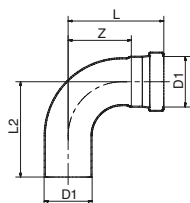



ELBOW - 45 DEGREE

Product Code	Size (D1)	L	Z
404838	65mm	82	38
404839	80mm	95	45
404840	100mm	118	57

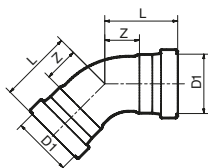

ELBOW M&F - 45 DEGREE

Product Code	Size (D1)	L1	Z	L2
404848	65mm	82	38	93
404849	80mm	95	45	100
404850	100mm	117	57	130

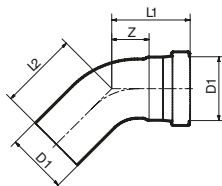

TEE

Product Code	Size (D1 x D2 x D3)	L1	L2	L3	Z1	Z2	Z3
404799	65mm	89	89	104	45	45	46
404800	80mm	101	101	111	50	50	52
404801	100mm	128	128	135	67	67	67

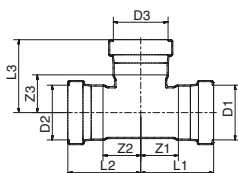

REDUCING TEE

Product Code	Size (D1 x D2 x D3)	L1	L2	L3	Z1	Z2	Z3
404802	65 x 65 x 50mm	84	84	90	40	40	44
404803	80 x 80 x 50mm	90	90	96	39	39	50
404804	80 x 80 x 65mm	93	93	108	42	42	52
404805	100 x 100 x 50mm	105	105	108	44	44	63
404806	100 x 100 x 65mm	105	105	123	44	44	66
404807	100 x 100 x 80mm	112	112	124	51	51	66

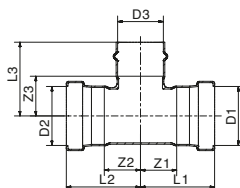

END CAP

Product Code	Size (D1)	L	Z	Rp
404841	65mm	86	21	3/4"
404842	80mm	98	28	3/4"
404843	100mm	115	39	3/4"

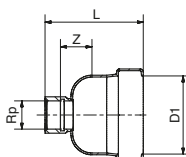

*Note: You will need a 20mm threaded plug to cap off the end.



STRAIGHT CONNECTOR

Product Code	Size (D1)	L	Z
404867	65mm	92	4
404868	80mm	106	4
404869	100mm	126	4

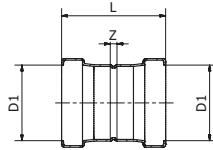

REPAIR COUPLER

Product Code	Size (D1)	L
405130	65mm	110
405131	80mm	125
405132	100mm	144

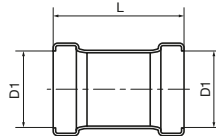

REDUCING COUPLING

Product Code	Size (D1 x D2)	L1	Z
404888	65 x 32mm	101	30
404889	65 x 40mm	100	25
404890	65 x 50mm	100	24
404891	80 x 40mm	117	40
404892	80 x 50mm	119	36
404893	80 x 65mm	119	25
404894	100 x 50mm	142	49
404895	100 x 65mm	134	31
404896	100 x 80mm	135	25

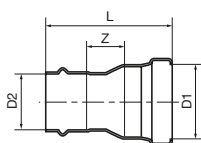

FITTING REDUCER

Product Code	Size (D1 x D2)	L	Z
404897	65 x 40mm	106	75
404898	65 x 50mm	103	66
404899	80 x 50mm	122	89
404900	80 x 65mm	131	87
404901	100 x 50mm	145	112
404902	100 x 65mm	139	96
404903	100 x 80mm	136	86

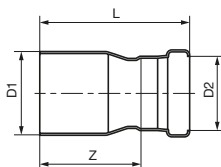



MALE COUPLING

Product Code	Size (D1 x R)	L	Z	S
405124	65mm x 2 1/2"	121	78	85
405125	80mm x 3"	126	78	95
405126	100mm x 4"	150	91	125

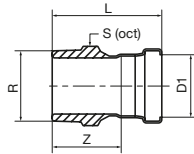

FEMALE COUPLING

Product Code	Size (D1 x Rp)	L	Z	S
405127	65mm x 2 1/2"	112	31	85
405128	80mm x 3"	114	33	95
405129	100mm x 4"	138	37	125

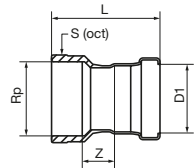

ELBOW - 90 DEGREE

Product Code	Size (D1 x D2)	L	Z
404870	65mm	126	82
404871	80mm	150	98
404872	100mm	192	132

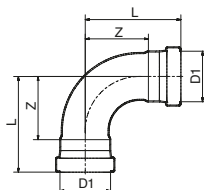

ELBOW M&F - 90 DEGREE

Product Code	Size (D1)	L	Z	L2
404923	65mm	132	88	146
404924	80mm	150	98	148
404925	100mm	192	132	212

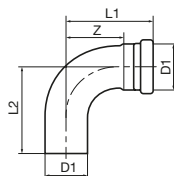



ELBOW - 45 DEGREE

Product Code	Size (D1)	L	Z
404904	65mm	82	38
404905	80mm	95	45
404906	100mm	118	57

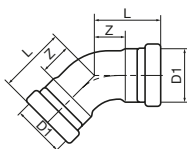

ELBOW M&F - 45 DEGREE

Product Code	Size (D1)	L1	Z	L2
404914	65mm	82	38	93
404915	80mm	95	45	100
404916	100mm	117	57	130

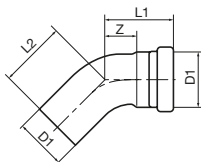

TEE

Product Code	Size (D1 x D2 x D3)	L1	L2	L3	Z1	Z2	Z3
404873	65mm	89	89	104	45	45	46
404874	80mm	101	101	111	50	50	52
404875	100mm	128	128	135	67	67	67

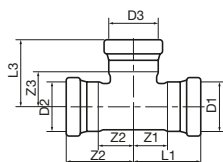

REDUCING TEE

Product Code	Size (D1 x D2 x D3)	L1	L2	L3	Z1	Z2	Z3
404876	65 x 65 x 50mm	84	84	90	40	40	44
404877	80 x 80 x 50mm	90	90	96	39	39	50
404878	80 x 80 x 65mm	90	90	96	39	39	50
404879	100 x 100 x 50mm	105	105	108	44	44	63
404880	100 x 100 x 65mm	105	105	123	44	44	66
404881	100 x 100 x 80mm	112	112	124	51	51	66

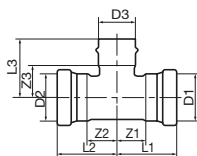

END CAP

Product Code	Size (D1)	L	Z	Rp
404907	65mm	86	21	3/4"
404908	80mm	98	28	3/4"
404909	100mm	115	39	3/4"

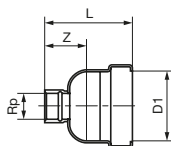

*Note: You will need a 20mm threaded plug to cap off the end cap.

› Installation Requirements ‹





Design Considerations

Pipework support

All pipework should be supported by the use of appropriate clips, brackets or supports. Please refer to requirements listed in AS/NZS 3500 for specific details in relation to the particular application.

Distance between fittings

Due to the reforming of the tube profile when pressed, it is advised that a minimum distance is allowed between each fitting.

Tube Size	Minimum Clearance F (mm)
15mm	5
20mm	5
25mm	5
32mm	10
40mm	15
50mm	20
65mm	15
80mm	15
100mm	15

F – Clearance Between Fitting Ends

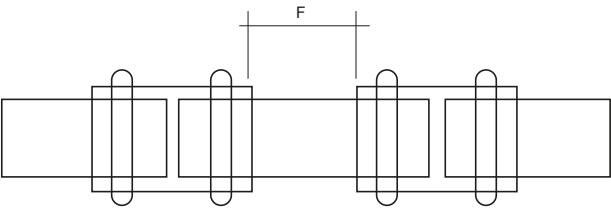

Minimum clearance requirements

The following minimum clearances are required from structural components to allow operation of tool for press fitting.

Tube Size	Minimum Clearance (mm)	
	Romax Compact/Compact TT	Romax 3000/4000
15-25mm	35	45
32-50mm	-	45
65-100mm	-	45

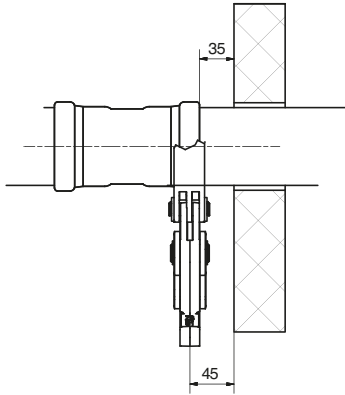

Tube Size	Minimum Clearance (mm)				
	A	B	C	D	E
65mm	90	130	90	90	150
80mm	95	145	95	100	165
100mm	110	165	110	115	190

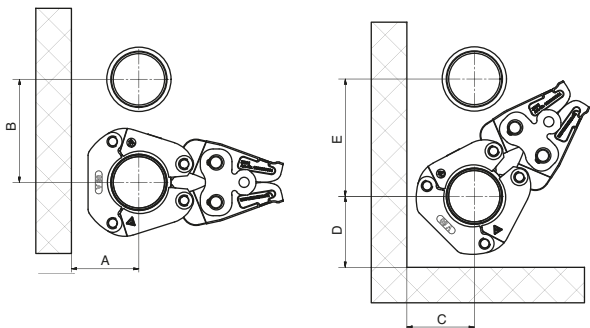

Pipework protection

Copper has a high resistance against corrosion. However, in some cases external protection may be necessary against corrosive conditions. Please refer to AS/NZS 3500 and AS/NZS 5601 for full pipework protection requirements for water and gas installations, respectively.

Localised annealing

To ensure proper sealing of both the brazed and >B< Press fitting, the following minimum distances must be maintained between the two fittings.

Tube Size	Minimum Clearance F (mm)
15mm	5
20mm	5
25mm	5
32mm	10
40mm	15
50mm	20
65mm	15
80mm	15
100mm	15

Note: It is important that there is no residual solder or other foreign debris on the tubing to be inserted into the >B< Press fitting. The surface condition on the area of press joint should be as tube standard AS 1432.

Brazing near >B< Press fittings

Caution – Brazing or soldering near >B< Press joints should be avoided as this may cause the seal to degrade due to heat transfer. The table below states the minimum distance away from the press joint which is acceptable to braze. If this distance cannot be maintained, then adequate precautions must be taken such as fabricating the brazed section prior to assembly with the press fittings, wrapping in a wet rag or applying a heat barrier (such as Rectorseal Hot Block), to prevent heat transfer to the press fitting during brazing.

Tube Size	Minimum Clearance F (mm)
15mm	350
20mm	500
25mm	650
32mm	800
40mm	1000
50mm	1300
65mm	1600
80mm	2000
100mm	2500

Flushing of water installations

When the installation is complete, it is essential to flush with water to remove dust and debris in accordance with AS/NZS 3500.

Testing and commissioning installations

The unique pressing indicator is a specially designed O-ring. It has a reduced section in two positions that allows water or air past the sealing element of any unpressed connection, thereby providing a visible leakage point during the commissioning of the system. Unpressed fittings are identified by pressurising the system with a pressure range of 100kPa to 500kPa for water and 2.2kPa to 300kPa for gas. When the fitting is pressed, the O-ring material compresses, filling the gaps, creating a leak free joint. During installation and before putting >B< Press into service, it is advisable to make a certain number of checks including:

All fitting connections in a system should remain visible and accessible until leak and pressure tested.

WATER SYSTEMS

To ensure that all press joints have been successfully completed, a low pressure test is applied as follows:

- After flushing, fill the system with water and check for visible leaks.
- No leak. Apply a test pressure of between 100 and no more than 500kPa.
- No leak. Final testing should be conducted in accordance with AS/NZS 3500.

GAS SYSTEMS

If a joint has not been pressed, it will not hold pressure when tested at 2.2 to 300kPa.

Test as per the normal requirements of AS/NZS 5601.

> The Tools <





**The following tools are
the only tools approved
for use on Conex Bänninger
>B< Press fittings:**

- Rothenberger Romax Compact TT
- Rothenberger Romax 4000
- Rothenberger Romax Compact
- Rothenberger Romax 3000
- Viega Picco
- Viega PT3-AH, 4B, 5B, 6

Recommended Tools

Rothenberger press tools and jaws have been specifically engineered for >B< Press

With strict Australian piping tolerances, it is imperative that your tool works in unison with your press fittings. Therefore, it is recommended to use Rothenberger press tools when installing >B< Press for the best press solution.

Rothenberger Romax Compact TT



Application sizes: 15-32mm >B< Press Fittings

- Compact, lightweight, twin cylinder design – optimised for one hand operation.
- CFT® – technology for constant axial 19kN shearing force.
- Safety latch to ensure jaw cannot come out during operation.
- Easy to use LED status indication – flashing red when battery charge is low and will lock the machine.
- Simple and safe operation design with hold start button – tool automatically stops once press cycle is complete.
- Safety yellow button – press to release pressure and stop press cycle.
- Convenient 20,000 cycle interval between service requirements.
- Head positioning up to 270° rotation – easy fitting in difficult locations.
- Li-Ion battery technology – long lasting operation between charges.
- Patented AIR COOLED charging technology.

Rothenberger Romax Compact TT Tool Kits



Rothenberger Romax Compact TT Tool and Jaw Kits

Code	Description
8078100	Rothenberger Compact TT Tool Only
8078107	Rothenberger Compact TT >B< Press Tool Kit 15-25mm
8078050	Rothenberger Compact TT >B< Press Jaw & Case Set 32-40mm

Specifications

Battery voltage – 18V

Battery capacity – 2Ah and 4Ah

Max piston force – 19kN

Pressing time – 3 seconds

Dimensions (LxWxH) – 8cm
x 14.3cm x 33.6cm

Weight (less jaws) – 2.5kg

Working range:

Copper System 15 - 40mm

Typical A-rate noise level – 71dB(A)

Battery re-charge time
periods – 2Ah = 40 minutes,
4Ah = 80 minutes

Rothenberger Romax[®]

4000 model



Application sizes: 15-100mm >B< Press Fittings

Ergonomically designed and better weight distribution compared to the 3000 – reducing fatigue during extended use.

- Wide application range.
- Fast pressing – automatic cycle complete in 4 seconds.
- Easy to use LED status indication – flashing red when battery charge is low and will lock the machine, remains ON when tool has reached 40,000 cycles of use and requires servicing.
- Bright white - light LEDs to illuminate work space during pressing cycle.
- Simple and safe operation design – hold start button – tool automatically stops once press cycle is complete.
- Safety yellow button – press to release pressure and stop press cycle.
- Long 40,000 cycle interval between service requirements.
- Head positioning up to 270° rotation – easy fitting in difficult locations.
- Li-Ion battery technology – long lasting operation between charges.

Romax 4000 Tool Kits



Rothenberger Romax 4000 Tool and Jaw Kits

Code	Description
7701304	Rothenberger 4000 Tool Only 18v
7701000	Rothenberger 4000 >B< Press Tool Kit 15-50mm
7701206	Rothenberger 3000/4000 >B< Press Jaw Set 65-100mm

Specifications

Battery voltage – 18V

Battery capacity – 2Ah and 4Ah

Rated power consumption
– 540 Watts

Max piston force – 32kN

Pressing time – 4 secs (nominal)

Dimensions (LxWxH)
– 447x125x75mm

Weight (less jaws) – 3.54 kg

Working range:

Copper System 15 - 100mm

Typical A-rate noise level – 71dB(A)

Battery re-charge time periods
2Ah = 40 minutes, 4Ah
= 80 minutes

Rothenberger XL Press Jaws & Actuator

For Romax® Press Tools



An actuator and appropriately sized jaw are required to press >B< Press XL fittings.

To complete a press, the jaw is opened and located on the fitting bead. The actuator is connected to the tool, ensuring the locking pin is fully engaged. With the actuator fitted in the press tool, open the actuator and locate the actuator into the aperture of the pressing ring. To perform the press, hold the trigger of the tool until the press cycle of the tool is automatically completed.

XL Press Jaws For Romax® Press Tools

- Made of forged, highly resilient special steel
- Compact design
- Long-term corrosion protection
- Optimised for minimal space requirements



Actuator For Romax® Press Tools

- Precision-manufactured contours for optimum and reliable pressings
- Made of forged, highly resilient special steel
- Long-term corrosion protection



Critical Operating Instructions - Tool & Jaw

Only operate the Rothenberger press tool and jaws as per instructions in your 'User Operating Manual, Instructions for Use'. Proper usage includes compliance with the operating manual, inspection and servicing conditions and adherence to all relevant safety regulations. The equipment must only be used by qualified tradespeople that have a trained understanding on how to use the press tool and jaw system properly. Failure to do so will lead to safety risk, poor workmanship, and incorrect use of the press tool and jaw that is not covered under warranty. Only use Rothenberger press tool and jaws with compatible press fittings that have been tested and approved by Rothenberger and associated fitting and pipe manufacturers (>B< Press, Auspex, Duopex).

- Always start with a safety check, reminding yourself of the yellow emergency stop button to deactivate a press cycle.
- Charge battery fully before first use for optimal number of 'presses per charge'.
- LED flashes red to indicate when you have a flat battery.
- Insert battery correctly until it clicks into place and LED light flashes briefly to indicate contact made.
- Insert press jaw and close bolt down correctly. Only use the correct jaw to tool to fitting combination.
- Open the jaw by squeezing from the base of the jaw NOT the front tip (it can crush your fingers!).
- Place jaw squarely on fitting. Align with bead.
- Half engage the start button for the handy LED lights.
- Fully engage the start button for a full press cycle. Activate the press tool and jaw only on a fitting.
- Take the time to ensure the correct pipe preparation – cut pipe square, deburr, remove sharp edges and oxidation and mark insertion depth. These pipe prep steps are critical for a correct press and quality workmanship.
- Follow all installation instructions supplied by the fitting and pipe manufacturers. Imperfect pipe joints must only be pressed again using a new fitting, DO NOT re-press the same fitting.
- During the press cycle, visually check that the press jaw fully closes at the end of the press cycle.
- After pressing, check the installation with appropriate testing equipment and ensure it is leak-proof.

Regular Maintenance Instructions

Tool & Jaw

Tool – Always clean and grease and store in case

Your Rothenberger Tool is one of the lightest and most ergonomic designed tools that delivers the most consistent press force (CFT® - Constant Force Technology). With regular maintenance and service it generates up to 3.2 tonnes of force in your hand, so it requires regular care and maintenance.



1. Clean and grease the piston ram and drive rolls ALWAYS after every use to maintain performance – especially the internal guide rail OR all the 'moving metallic parts'.
- Watch heavy water areas. Do not expose power tools to rain or wet conditions. Always store in case.



2. Ensure the jaw locking bolt is closed correctly by fully inserting the bolt through the jaw and rotating the bolt arm down 180 degrees.
- **Note:** The bolt is only secured when fully inserted and rotated into the downward position.



Battery – Always clean contact points and store in a charged state



1. Clean contact points on battery and only store battery in a charged state, plus it's always ready for use.
- Do not force the press tool – it will do the job better and safer at the rate for which it was designed.
 - Accidents are caused by poorly maintained press tools and jaws. Take the time to maintain properly.

Jaws – Always clean, apply lubricant spray and store in case



1. Clean jaws ALWAYS after every use. Keep the inside jaw profile free of any grease and grit.
- Jaws must be maintained with liquid lubricant spray. Do not use spray on the tool, only the jaws.
 - Ensure any excess spray is removed. Always store in case.



Servicing and Warranty - Tool and Jaw

Rothenberger prides itself on leading edge design, the highest quality, and leading after-sale service support. With ownership of your Rothenberger Tool comes our commitment to support you. We want to help you look after your tool, so you don't compromise your reputation.

- Simply return your Rothenberger press tool and jaw set to your local Reece branch – they will sort out the rest.
- A qualified tool service technician will inspect and service your tool to ensure high performance and safety.
- Comprehensive spare parts are readily available locally to support your Rothenberger tool and jaws.
- Jaws will also be checked at the annual service interval for any damage, defects and general wear and tear that could affect the press performance or safety.

Warranty Coverage

- After 1 year or 20,000 (Romax Compact/Compact TT) or 40,000 (Romax 3000/4000) presses the LED lights up red after each press.
- A press cycle count will be made as part of your annual tool and jaw servicing and report.
- If a serial number sticker is damaged, the warranty will be null and void.
- The warranty does not cover damage caused by incorrect use of the equipment.
- Tool 4 years, only with regular 1 year or cycle count servicing (like servicing your car!).
- Battery 12 months, jaws 12 months.

> Frequently Asked Questions <

Q. How long has Conex Bänninger been around?

A. Since 1909.

Q. Where are the products manufactured?

A. Poland and Spain.

Q. What grades of copper tube do the fittings suit?

A. Annealed, half hard and hard drawn type A and B plumbing tube to AS1432.

Q. How do you install >B< Press fittings?

A. Please see 'Installation Instructions' section on pages 20-21 for >B< Press, and pages 60-61 for >B< Press XL.

Q. Can you press a fitting more than once?

A. No, >B< Press fittings can be pressed only once.

Q. Can you rotate a >B< Press fitting once installed?

A. No, once pressed, they cannot be rotated.

Q. Can >B< Press be dismantled and reused?

A. No, this is a permanent installation.

Q. Can the O-rings from Water and Gas fittings be swapped?

A. No, the O-ring is integral to the seal of the fitting. Swapping the O-ring increases the risk of damage and therefore O-rings are not to be interchanged. Water and Gas O-rings are also made from different materials and are therefore not suitable for the same applications.

Q. What pipe preparation is required?

A. Please see 'Installation Instructions' on pages 20-21 for >B< Press and pages 60-61 for >B< Press XL.

Q. When using with older pipes, how do you prepare the surface?

A. The surface should be prepared in the same way as with new pipe. Provided there is no corrosion, the tube dimensions comply with AS 1432 (type A & B) and the fittings are installed correctly, there are no warranty issues. *Note: Warranty is limited to faults due to the manufacturing defects of the fittings – not incorrect installation or installation on faulty or corroded pipe.

- Q. What applications can >B< Press be used in?
- A. >B< Press fittings are suitable for use across a wide range of applications, depending on medium, temperature and pressure. Please see 'Technical Data' section on pages 16-19.
-

- Q. What pressure do you need to test to and for how long to show any leaks?
- A. Unpressed fittings are identified by pressurising the system with a pressure range of 100kPa to 500kPa for water and 2.2kPa to 300kPa for gas. Final testing of the system should be conducted in accordance with AS/NZS 3500 and/or AS/NZS 5601.
-

- Q. If a fitting leaks on installation, can you weld the fitting rather than cutting out the joint and having to replace missing tube?
- A. No, if a fitting that has been pressed is leaking, the fitting must be cut out and replaced. You should not attempt to weld the fitting as you will melt the O-ring, destroying the sealing element.
-

- Q. What material is the O-ring made of?
- A. The O-ring is manufactured from a high quality:
- Black Ethylene Propylene Diene Monomer (EPDM) material for Water fittings
 - Yellow Hydrogenated Nitrile Butadiene Rubber (HNBR) material for Gas fittings
 - Red Fluorocarbon (FKM) material for High Temperature fittings
-

- Q. Can it be used with medical gas?
- A. No, the fittings are not recommended for use with medical gas.
-

- Q. Can it be exposed to direct sunlight and heat?
- A. Yes – please see table on pages 16-19 for limitations due to pressure and temperature.
-

- Q. Does the clipping of fittings/jobs differ from a welded copper application?
- A. No, the same type of clips can be used. See 'Pipework support' on page 76.
-

- Q. Can the fittings be placed in ground with all types of soils?
- A. Yes – however, whilst copper has a high resistance against corrosion, in some cases external protection may be necessary against corrosive conditions. Refer to AS/NZS 3500 and AS/NZS 5601 for full pipework protection requirements.
-

Q. Can the fittings be used for solar installations?

A. >B< Press Water fittings are not recommended for solar installations. >B< Press High Temperature fittings are recommended for these installations.

Q. What is the recommended space between fittings?

A. Please see 'Distance between fittings' section on page 76.

Q. Can the fittings be used on compressed air or oil lines?

A. >B< Press Water fittings are recommended for compressed air (oil free) and >B< Press Gas fittings are suitable for all compressed air applications.

Q. What are the benefits of >B< Press fittings?

A. >B< Press is a flame-free solution, that is fast, simple and reliable to install. Please see 'Key Features' section on pages 4-5.

Q. Are there any restrictions in regards to where flanges can be used?

A. Providing the selection of the sealing gasket considers the same system parameters and application, flanges may be used in all situations that other >B< Press fittings cater for.

Q. Can you braze (silver soldering) near a >B< Press connection?

A. Please see 'Brazing near >B< Press fittings' section on page 78.

Q. Can >B< Press handle suction or negative pressure?

A. Yes, >B< Press fittings are tested at a vacuum test pressure of -80kPa at ambient temperature.

Q. Can >B< Press be installed on pipes where the mains line won't shut off?

A. Yes, the fitting can be used in wet conditions and after pressing, will provide a watertight joint.

Q. Do I need to lubricate the O-ring?

A. No, the O-ring is prelubricated. Additional lubricants could impact on the life of the O-ring and void the warranty. If the O-ring appears dry, a small amount of water can be used to lubricate it.

- Q. Can >B< Press fittings be used on chrome tube?
- A. Yes, provided that the tube complies with AS1432. However, it is recommended to test a piece first as some splitting of the chrome may occur.
-

- Q. When pressed on small size fittings, (particularly elbows) a small amount of rotational movement can be induced to the joint. Will this affect the security of the joint?
- A. No, some rotational movement is quite acceptable, the joint will not leak nor will it come apart under the pressure loading and during system operation. Some joint movement is good as it will allow for expansion and contraction in the pipework system.
-

- Q. How should >B< Press fittings be stored?
- A. Fittings should be stored in a cool, dry place in their original packaging. This protects the fittings from contamination, damage and dirt and conserves the lubrication on the O-rings prior to installation.
-

- Q. What is the warranty on >B< Press fittings?
- A. >B< Press has a 25 year warranty from the date of purchase. This covers against faults caused by defective manufacture of fittings. It does not cover faults arising from incorrect installation. All >B< Press fittings must be installed by a licensed plumber.
-

- Q: What fittings have the new 360 Detect o-ring?
- A: 15-50mm water and hi temp fittings. See page 16 for more details
-

For more information, visit
www.conexbanninger.com.au

Download this guide:



Reece. Works for you.™

Call **1800 032 566** or visit www.reece.com.au for your nearest Reece store.

The manufacturer/distributor reserves the right to vary specifications or delete models from their range without prior notification. The manufacturer/distributor takes no responsibility for printing errors. All measurement and content details in this brochure are subject to a tolerance of $\pm 3\%$.

V8 [BROCHURE CODE 2130196]

Conex Bänninger

