

# mizu

## Mizu Bloc Overhead Shower 250mm Brushed Nickel (3 Star)

29712

### SPECIFICATIONS

Recommended Use	Residential;Commercial
Colour Finish	Brushed Nickel
Primary Material	Stainless Steel
Recommended Pressure Range	150 - 500 kPa as per AS3500
Max Continuous Working Temperature (deg C)	65
Min Continuous Working Temperature (deg C)	5

### WARRANTY

Residential & Commercial Use (Years)	25
Spare Parts & Labour (Years)	1

Please refer to Mizu Warranty page for full Terms and Conditions

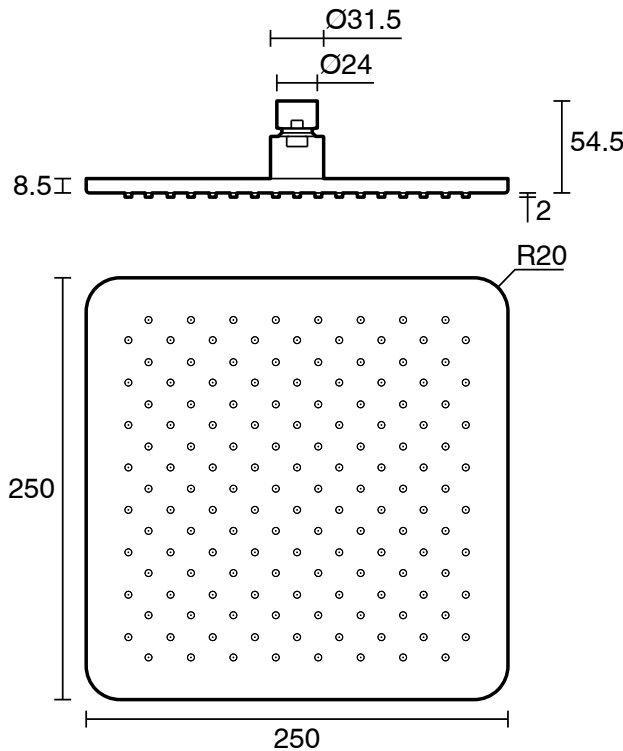
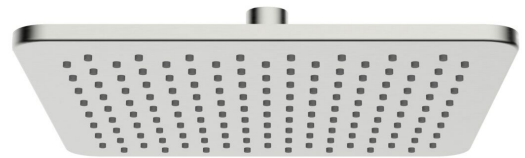

Dimensions are nominal measurements only.

### CLEANING RECOMMENDATIONS:

We recommend the use of soapy water or approved cleaners. This product should not be cleaned with abrasive materials. Damage caused by any improper treatment is not covered by the product warranty. Refer to Warranty Conditions

**Disclaimer:** Products in this specification manual must by regulation be installed by licensed and registered trade people. The manufacturer/distributor reserves the right to vary specifications or delete models from their range without prior notification. Dimensions are nominal measurements only. Dimensions and set-outs listed are correct at time of publication however the manufacturer/distributor takes no responsibility for printing errors.

Published 01/04/2026

To see the complete Mizu range go to [www.reece.com.au](http://www.reece.com.au)

