



Touch



Motion

Touch Motion BC

Code	Product
48158	Billi Eco TM Small BC 10P - Brushed Chrome
48159	Billi Eco TM Small BC 10P - Chrome
48160	Billi Eco TM Small BC 10P - Matte Black
48161	Billi Quadra Compact TM Med BC 20P - Brushed Chrome
48162	Billi Quadra Compact TM Med BC 20P - Chrome
48163	Billi Quadra Compact TM Med BC 20P - Matte Black
48164	Billi Quadra 420 TM Med BC 25P - Brushed Chrome
48165	Billi Quadra 420 TM Med BC 25P - Chrome
48166	Billi Quadra 420 TM Med BC 25P - Matte Black
48167	Billi Quadra 440 TM Med BC 40P - Brushed Chrome
48168	Billi Quadra 440 TM Med BC 40P - Chrome
48169	Billi Quadra 440 TM Med BC 40P - Matte Black
48170	Billi Quadra 460 TM LGE BC 60P - Brushed Chrome
48171	Billi Quadra 460 TM LGE BC 60P - Chrome
48172	Billi Quadra 460 TM LGE BC 60P - Matte Black
48173	Billi Quadra 4100 TM XLGE BC 100P - Brushed Chrome
48174	Billi Quadra 4100 TM XLGE BC 100P - Chrome
48175	Billi Quadra 4100 TM XLGE BC 100P - Matte Black
48176	Billi Quadra 4180 TM XLGE BC 180P - Brushed Chrome
48177	Billi Quadra 4180 TM XLGE BC 180P - Chrome
48178	Billi Quadra 4180 TM XLGE BC 180P - Matte Black

Touch Motion BCS

Code	Product
48179	Billi OmniOne Pro20 TM Med BCS 10P - Brushed Chrome
48180	Billi OmniOne Pro20 TM Med BCS 10P - Chrome
48181	Billi OmniOne Pro20 TM Med BCS 10P - Matte Black
48182	Billi OmniOne Pro60 TM LGE BCS 60P - Brushed Chrome
48183	Billi OmniOne Pro60 TM LGE BCS 60P - Chrome
48184	Billi OmniOne Pro60 TM LGE BCS 60P - Matte Black

Built for performance. Backed by BWT.

Billi systems use world-leading BWT filtration for reliable, high-quality water and system protection. RFD technology ensures filters are replaced on time helping maintain safe, clean drinking water. NSF tested. WaterMark certified. Built for installs you can trust.

Billi replacement filters come in a range of options designed to reduce:

- ✓ Sediment
- ✓ Chlorine
- ✓ Parasitic Cysts (0.2 micron models)
- ✓ Taste & odour

Delivering cleaner, healthier, better-tasting water.



Certifications



Billi Australia Pty Ltd
1/21-35 Radford Road,
Reservoir, Victoria 3073
Australia

P 1800 812 321
W www.billi.com.au



XT Motion)))

First of it's kind – Touch & Motion Sensor Tap



Features



Dual Control Options

Contactless & Tactile for a seamless experience.



Sparkling Water Integration

Adds a premium, health-conscious option



First-to-Market Technology

Touch Motion is uniquely engineered to meet the highest standards of convenience, hygiene and safety.



Smart Design

The smartest, most hygienic hydration tap for modern commercial and healthcare spaces.



3-in1 Tap

3 in 1 hydration with boiling, chilled and sparkling options



New Experience

Not just another tap - it's a whole new interaction experience

Ideal Environments

Healthcare & Aged Care

Engineered for clinical and aged care settings where hygiene is essential. The Touch Motion touchless technology provides a hygienic hydration solution for staff, patients, and residents.

Workplace & Commercial

Designed for high-traffic modern offices and commercial hubs. Scalable systems provide reliable, hygienic hydration for teams ranging from 10 to 180 people.

Finishes & Specifications

Touch Motion



Touch Motion represents Billi's dedication to merging advanced design with functionality, making it an essential addition to any modern space

AVAILABLE FINISHES



Chrome



Brushed



Matte Black

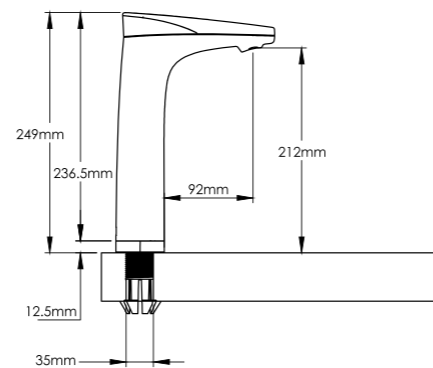

Function



Boiling, chilled & sparkling



Safety Lock



Sparkling



Chilled



Boiling



Boiling & chilled



Safety Lock



Chilled



Boiling

Underbench Specifications

Available with Boiling, Chilled & Boiling, Chilled & Sparkling systems in small - extra large capacities.

Billi Eco



Eco

- ✓ Air-Cooled System
- ✓ Smallest Footprint

Model	Size	Suggested no. of people
Eco	SML	10

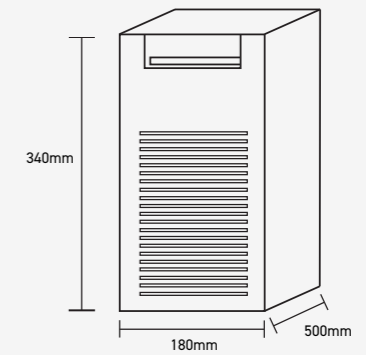

Billi Quadra



Quadra

- ✓ Scalable capacity
- ✓ Watercooled System
- ✓ Greentag Certified with EPD

Quadra Compact

- ✓ Small footprint
- ✓ Watercooled technology
- ✓ Greentag certified

Model	Size	Suggested no. of people
Quadra Compact	SML	20
Quadra 420	MED	25
Quadra 440	MED	40
Quadra 460	LGE	60
Quadra 4100	X-LGE	100
Quadra 4180	X-LGE	180

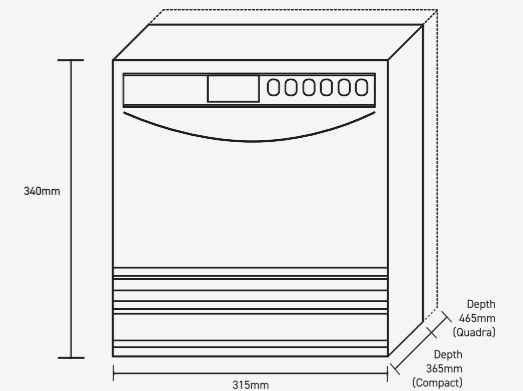

Billi OmniOne



OmniOne

- ✓ Advanced all in one technology
- ✓ Watercooled
- ✓ Whisper quiet
- ✓ Touch screen control
- ✓ Adjustable temps

Model	Size	Suggested no. of people
OmniOne Pro20	SML	20
OmniOne Pro60	MED	60

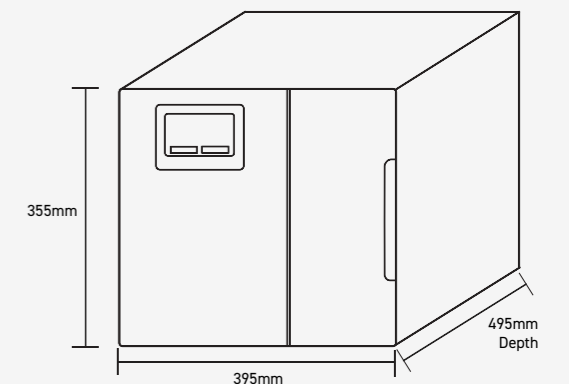

Site Preparation

Water Supply: A single 15mm 1/2") stop-tap with a male thread should be installed in an easily accessible position.

Water supply must be microbiologically safe to drink, with a minimum dynamic water pressure of 250kPa

Power Supply: Standard 10 amp AU power outlet. Unit is supplied with 1 metre flex cord and plug