

THERMANN™

INSTALLER'S AND OWNER'S GUIDE

IMPORTANT INFORMATION

Failure to follow these instructions may affect the Warranty

270L Heat Pump Water Heater

Installation Details
Owner's Information
Warranty

Models

270THMB36 | 270THMB36P

Note – an 'H' at the end of the model number indicates that the water heater has been pre-fitted with a hard-water anode (available in all models).



IMPORTANT SAFETY INFORMATION

WARNING - THIS APPLIANCE MAY DELIVER WATER AT HIGH TEMPERATURE. REFER TO THE PLUMBING CODE OF AUSTRALIA (PCA), LOCAL REQUIREMENTS AND INSTALLATION INSTRUCTIONS TO DETERMINE IF ADDITIONAL DELIVERY TEMPERATURE CONTROL IS REQUIRED.

WARNING - FOR CONTINUED SAFETY OF THIS APPLIANCE IT MUST BE INSTALLED, OPERATED AND MAINTAINED IN ACCORDANCE WITH THE MANUFACTURER'S INSTRUCTIONS.

This water heater is not intended for use by persons (including children) with reduced physical, sensory or mental capabilities, or lack of experience and knowledge, unless they have been given supervision or instruction concerning use of the water heater by a person responsible for their safety.

Children should be supervised to ensure they do not interfere with the water heater. Ensure animals are supervised so they do not interfere with the water heater.



THIS APPLIANCE USES R290 (PROPANE) REFRIGERANT, WHICH IS A FLAMMABLE GAS CLASS 3 ACCORDING TO ISO 817 AND MUST BE HANDLED BY A REFRIGERATION MECHANIC WITH APPROPRIATE AUSTRALIAN REFRIGERANT HANDLING LICENCE.

WARNING: RISK OF FIRE / FLAMMABLE MATERIAL. IF THE REFRIGERANT IS LEAKED, TOGETHER WITH AN EXTERNAL IGNITION SOURCE, THERE IS A POSSIBILITY OF IGNITION.

DO NOT STORE CHEMICALS OR FLAMMABLE MATERIALS, OR SPRAY AEROSOLS NEAR THIS WATER HEATER.

DO NOT STORE ANY COMBUSTIBLE MATERIAL NEAR THIS WATER HEATER.

DO NOT MODIFY THIS WATER HEATER.

DO NOT OPERATE THE WATER HEATER WITH ANY PANELS OR COVERS REMOVED.

DO NOT USE MEANS TO ACCELERATE THE DEFROSTING PROCESS OR TO CLEAN, OTHER THAN THOSE RECOMMENDED BY THE MANUFACTURER.

THE APPLIANCE SHALL BE STORED IN A ROOM WITHOUT CONTINUOUSLY OPERATING IGNITION SOURCES.

FOR EXAMPLE, OPEN FLAMES, AN OPERATING GAS APPLIANCE OR AN OPERATING ELECTRIC HEATER.

DO NOT PIERCE OR BURN.

BE AWARE THAT REFRIGERANTS MAY NOT CONTAIN AN ODOUR.

DO NOT INSERT YOUR FINGER, A STICK, OR OTHER OBJECTS INTO THE

IMPORTANT SAFETY INFORMATION

AIR INLET & OUTLET GRILLS. THIS MAY CAUSE INJURY, SINCE THE FAN INSIDE ROTATES AT HIGH SPEEDS DURING OPERATION.

WARNING – IF THE WATER HEATER IS NOT USED FOR TWO WEEKS OR MORE, A QUANTITY OF HYDROGEN (WHICH IS HIGHLY FLAMMABLE) MAY ACCUMULATE INSIDE THE WATER HEATER TANK. TO DISSIPATE THIS GAS SAFELY, IT IS RECOMMENDED THAT A HOT TAP BE TURNED ON FOR SEVERAL MINUTES AT A SINK, BASIN OR BATH, BUT NOT A DISHWASHER, CLOTHES

WASHER OR OTHER APPLIANCE. DURING THIS PROCEDURE THERE MUST BE NO SMOKING, OPEN FLAME OR ANY OTHER ELECTRICAL APPLIANCE OPERATING NEARBY. IF HYDROGEN IS DISCHARGED THROUGH THE TAP IT WILL PROBABLY MAKE A SOUND SIMILAR TO AIR ESCAPING.

RELIEF VALVE:

The Pressure & Temperature Relief (PTR) Valve must be installed with the brass reducer directly into a RP $\frac{3}{4}$ "(DN20) socket marked "RELIEF VALVE".

The PTR Valve rating is 1,000 kPa and 10 kW.

The valve must not be tampered with or removed. The water heater must not be operated unless this valve is fitted and in working order.

The drain line from the PTR Valve must be installed in a continuously downward direction and in a frost free environment.

The PTR Valve is to be operated regularly to remove lime deposits and to verify it is not blocked. The drain line fitted to the PTR Valve must be left open to the atmosphere.

DANGER: FAILURE TO OPERATE THE PTR VALVE EASING LEVER AT LEAST ONCE EVERY SIX MONTHS MAY RESULT IN THE WATER HEATER EXPLODING. CONTINUOUS LEAKAGE OF WATER FROM THE VALVE MAY INDICATE A PROBLEM WITH THE WATER HEATER.

The PTR Valve should be checked by a licensed tradesperson for adequate performance, or replaced at intervals not exceeding 5 years, or less in areas where local regulations apply or in poor water quality areas.

It is normal for water to drip from the drain line fitted to the PTR Valve during heating cycles.

Continuous leakage of water from the PTR Valve may be caused by excessive water supply pressure, a faulty PTR Valve or a faulty thermostat.

Turn off the water heater and contact Customer Service

- 1300 412 612 (Australia);
- 0800 081 909 or contact your local Reece branch (New Zealand).

IMPORTANT SAFETY INFORMATION

OVER-TEMPERATURE ENERGY CUT-OUT:

The operation of the over-temperature energy cut-out on the thermostat indicates a possibly dangerous situation. Do NOT reset the overtemperature energy cut-out until the water heater has been serviced by a licensed tradesperson.

ELECTRICAL SAFETY:

This water heater is designed for single phase 230 - 240V a.c. supply only. The electrical connection must comply with Local Supply Authority Regulations and AS/NZS 3000 (known as the Wiring Rules). A means for disconnection must be incorporated in the fixed wiring in accordance with the Wiring Rules.

Any electrical covers should be removed only by a licensed tradesperson, and only after the electrical supply to the water heater has been isolated.

Warning- Do not replace the heating element with one of higher heating capacity.

In addition to the PTR Valve, the water heater is fitted with a thermostat and over-temperature energy cut-out.

These devices must not be tampered with or removed. Replacement of these devices must only be carried out by a licensed tradesperson or the manufacturer.

The water heater must not be operated unless these devices are fitted and in working order.

COLD WATER CONNECTION:

The water heater is intended to be permanently connected to the water supply main, and not connected by a hose-set.

This water heater is designed for direct connection to water supply pressures of up to 800 kPa.

Where the mains pressure can exceed or fluctuate beyond this pressure, a pressure reducing valve must be fitted in the cold water inlet supply.

Instructions explaining how the water heater can be drained can be found on page 7.

IMPORTANT SAFETY INFORMATION

INSTALLATION REQUIREMENTS

General:

This water heater must be installed by a licensed tradesperson, and in accordance with:

- In Australia, the Plumbing Code of Australia (PCA);
- In New Zealand, Clause G12 of the New Zealand Building Code (NZBC);
- AS/NZS 3000 Electrical Installations (known as the Australian / New Zealand Wiring Rules); and
- Local authority regulations.

Outside Australia and New Zealand, please refer to local plumbing and building codes and regulations.

Failure to comply with these requirements may affect the warranty.

AS/NZS 3500.4 Plumbing and Drainage – Heated Water Services provides a Deemed-to-Satisfy Solution for the PCA and a Verification Method for Clause G12 of the NZBC. Other methods of compliance are available. It is recommended that installations conform with AS/NZS 3500.4.

Note for Victoria:

This water heater must be installed by a licensed person as required by the Victorian Building Act (1993).

Only a licensed person will provide a compliance certificate, showing that the work complies with all the relevant Standards. Only a licensed person will have insurance protecting their workmanship.

Pool Heating:

This water heater must **not** be used for pool heating.

Location:

The water heater is only suitable for outdoor installation.

Ensure the compliance plate and associated warnings are clearly visible.

The water heater must be accessible without the use of a ladder or scaffold. Adequate clearance must be available for service to the electrical cover, refrigeration components, controller, relief valve and sacrificial anodes.

Avoid positioning the water heater near bedrooms or neighbours' bedrooms as the water heater may operate during the night.

The water heater should be located as close as possible to the most frequently used hot water outlet.

Circulated Hot Water Systems:

This water heater should not be installed as part of a circulated hot water flow and return system.

If a circulated flow and return system is required, it is recommended that a backup electric storage water heater is installed in the recirculation line.

Please consult Customer Service if required on

- 1300 412 612 (Australia);
- 0800 081 909 or contact your local Reece branch (New Zealand).

IMPORTANT SAFETY INFORMATION

Water Heater Support:

The water heater must be installed on a flat, solid supporting surface. The pipework must not be used to support the water heater.

Where the water heater is subjected to wet conditions, a plinth should be installed under the water heater.

A properly drained safe tray must be installed where property damage could occur from water spillage. Refer to AS/NZS 3500.4 for further information.

Clearances:

Before installation, please ensure that you leave the space as shown below for maintenance. Make sure there are no obstructions placed around the water heater to ensure adequate air flow.

See adjacent diagram.

Transport and Handling:

When moving the water heater, it must be kept in a vertical orientation at all times.

Never tilt the water heater more than 30° from vertical.

Tilting beyond 30° will severely affect the operation of the water heater and may void the warranty on the refrigeration components.

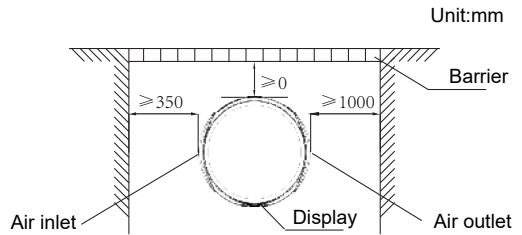

CAUTION: 1. The installation shall comply with AS/NZS 3500.4.
2. The minimum space of installation is 10 cubic meter.

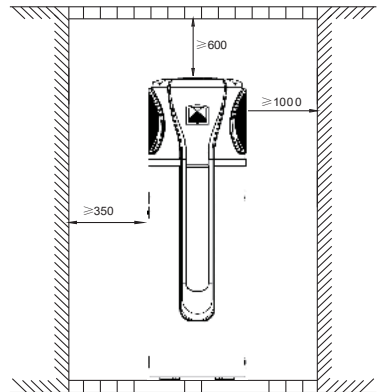

CONTENTS

Important Safety Information	i
Installation Requirements	iv
Plumbing Connections	2
Specifications	5
Filling and Draining	7
Electrical Connection	8
Wiring Diagram	9
Installation	10
Commissioning	11
Principle of Operation	12
Display Operation Guide	13
Mode Settings	16
Temperature Settings	24
Date & Time Settings	26
Timer Settings	29
Lock Settings	35
System Maintenance	36
Troubleshooting	39
Considering a Service Call?	41
Service & Decommissioning	43
Warranty	48

Specifications and materials may change without notice.

Effective for all Thermann 270L Heat Pump Water Heaters manufactured and sold after 1st January 2026.

PLUMBING CONNECTIONS

Water Supply:

This water heater has been manufactured to suit the water conditions of most Australian and New Zealand metropolitan supplies.

Please note certain water supplies can have a detrimental effect on the water heater and its life expectancy. If you are unsure about the water supply, you can obtain information from the local water supply authority.

The water heater is designed for use in areas where the Total Dissolved Solids (TDS) content of the water supply is less than 2500mg/L. The Tank Failure Warranty does not apply in areas where the TDS exceeds 2500mg/L.

In areas where the TDS exceeds 600mg/L, it is possible the magnesium alloy anode (supplied in standard water heaters) may become over-reactive. To alleviate this, a hard water model is recommended, or the magnesium alloy anode should be replaced with an

aluminium alloy anode. Aluminium alloy anodes are available from your local Reece branch.

The pH level of water supply should be between 6.5 to 9.5. Outside of this range, warranty is void.

Water can also be very corrosive, the measure of this is the saturation index. If the water saturation index is greater than 0.40, an expansion control valve should be fitted. Warranty does not apply if the Saturation Index (LSI) is less than -1.0 or greater than +0.8. LSI figures stated above are calculated with a water temperature of 80°C. Please consult Customer Service for advice if required

- 1300 412 612 (Australia);
- 0800 081 909 or contact your local Reece branch (New Zealand).

Cold Water Connection:

The water heater is intended to be permanently connected to the water supply main, and not connected by a hose-set.

Cold Water Connection Diagram:

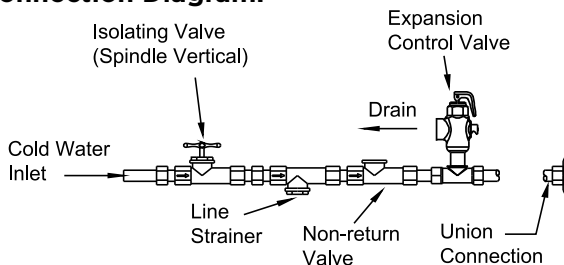

Note: a combined isolating valve/non-return valve/line strainer may be used.

The expansion control valve is only required where local regulations demand, although it is recommended in areas where the water saturation index is greater than 0.40.

PLUMBING CONNECTIONS

An approved isolating valve, non-return valve, line strainer (optional but recommended) and union must be fitted between the water supply main and a RP $\frac{3}{4}$ "(DN20) socket marked "INLET" at the bottom of the water heater. See the diagram below for details.

All fittings must be approved by the relevant Authority. Plastic pipes or fittings shall not be used between the isolating valve and the inlet.

Water Supply Pressure:

This water heater is designed for direct connection to water supply pressures of up to **800 kPa**.

Where the mains pressure can exceed or fluctuate beyond this pressure, a pressure reducing valve must be fitted in the cold water inlet supply.

Note for New Zealand, South Australia and Western Australia: It is a requirement in these locations that an expansion control valve be fitted on the cold water supply line between the non-return valve and the water heater.

Hot Water Connection:

The hot water pipe can be connected to the RP $\frac{3}{4}$ "(DN20) socket marked "OUTLET" at the top of the water heater.

It is recommended that all hot water pipes are insulated. Hot water pipes installed outdoors should be insulated with UV stabilised insulation.

Plastic pipes or fittings shall not be used within 1 metre of the outlet although they may be used downstream of a

temperature control valve. Refer to AS/NZS 3500.4 for further details.

Temperature Protection:

Water heaters can produce very hot water. To reduce the risk of scald injury, it is mandatory under the requirements of AS/NZS 3500.4 that an approved temperature control device is fitted to the hot water supply to outlets used primarily for personal hygiene. This device should be checked at regular intervals to ensure its operation and settings remain correct.

We recommend using a high performance tempering valve.

Relief Valve:

The Pressure & Temperature Relief (PTR) Valve is supplied with the water heater.

The PTR Valve rating is 1,000 kPa.

The PTR Valve rating is also shown on the compliance plate. The Pressure & Temperature Relief (PTR) Valve must be installed with the brass reducer directly into a RP $\frac{3}{4}$ "(DN20) socket marked "RELIEF VALVE". Ensure that a sealing material is applied to the PTR Valve to prevent water leaks.

The PTR Valve and its drain line must not be sealed or blocked.

The PTR Valve is not intended to enable connection of the water heater to supplementary energy sources such as solar panels or slow combustion stoves. Refer to AS/NZS 3500.4 for guidance on these types of installations.

PLUMBING CONNECTIONS

It is normal for the valve to leak a small amount of water during heating cycles.

Relief Valve Drain Line:

The drain line from the PTR Valve must be made of copper and run in accordance with the requirements of AS/NZS 3500.4. It must be installed in a continuously downward direction and in a frost free environment.

A separate drain line must be run for this valve. The drain line must not be directly connected to any other copper piping.

Condensate Drain Line:

A condensate drain point is located on the side of the water heater near the hot water outlet. A drain line must be connected to this point and run so that it discharges clear of the water heater.

The Condensate Drain Line must not be connected to the Relief Valve Drain Line although they may both discharge to the same point.

SPECIFICATIONS

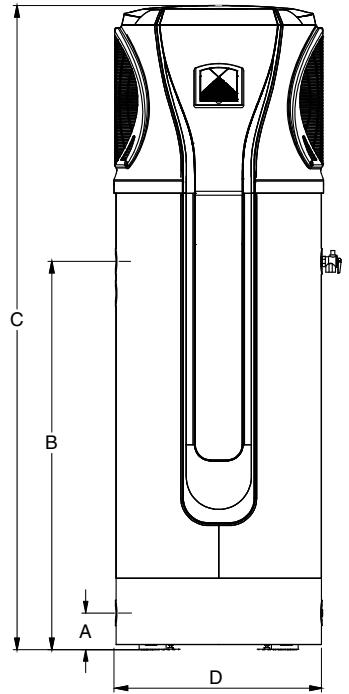
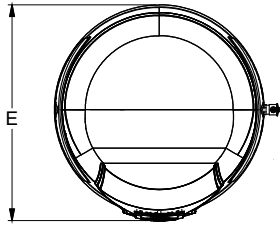

Nominal Dimensions (mm)	
Model	270THMB36 / P
Inlet/Drainage Height (A)	115
Outlet Height (B)	1211
Total Height (C)	2010
Nominal Diameter (D)	Ø640
Total Depth including Cover (E)	673

Specifications		
Model	270THMB36	270THMB36P
Storage Capacity (L)	270	270
Rated Heating Capacity (kW)	3.6	3.6
Max Current (A)	15.6	9.9
Electric Element Rating (W)	2400	1000
Refrigerant Type / Mass (g)	R290 / 680	R290 / 680
Net Weight (kg)	114	114
Max. Refrigerant Circuit Pressure (kPa)	3200	3200
Relief Valve Rating	1000kPa/10kW	1000kPa/10kW

SPECIFICATIONS

Model	270THMB36	270THMB36P
Power Supply (/)	230 - 240V ~/50Hz	
Moisture Resistance (IPX)	IPX4	
Rated Heating Capacity - Heat pump (kW)	3.6	
Auxiliary Electrical Heating (kW)	2.4	1
Rated Power Input (kW)	3.48	2.1
Rated Current Input (A)	14.5	8.8
Refrigerant / Proper Input (g)	R290 / 680g	
Unit Dimension (L/W/H) (mm)	Ø640 × 2010	
Rated Outlet Water Temperature (°C)	60	
Water Inlet/Outlet Pipe (inch)	3/4"	
Compressor	Rotary	

Measurement conditions: Instant heating; Ambient temperature 20°C /15°C ,

Water inlet 15°C Water outlet 55°C

Working range:

(1) Ambient temperature is -5°C to 43°C (Heat Pump).

(2) The max temperature of water tank is 70°C .

Operating parameters:

The range of the operating water temperatures: 10-60°C.

The range of the operating water pressures: 150 to 800 kPa.

Max. inlet water pressure: 800 kPa.

FILLING AND DRAINING

Filling the Water Heater:

The water heater must be filled with water before turning on the electrical supply.

1. Open all hot water taps.
2. Open the isolating valve at the cold water inlet slowly and allow the water heater to fill until water flows through the system.
3. Close each hot water tap after the air is expelled from its line.
4. Open the Pressure & Temperature Relief Valve for approximately 10 seconds by lifting the easing lever on the valve. Confirm water is relieved to waste through the relief valve drain pipe.
5. Lower the lever gently and check it closes correctly.

Draining the Water Heater:

1. Turn off the electricity supply to the water heater.
2. Turn off the cold water supply to the water heater at the isolating valve.
3. Gently operate the easing lever on the Pressure & Temperature Relief (PTR) Valve to release the pressure in the water heater.
4. Disconnect the cold water inlet union and attach a drain hose to the water heater. If an isolation valve is installed on the drainage connection of the water heater, it can be used to drain the water heater.
5. Gently operate the easing lever on the PTR Valve to let air into the water heater and allow water to escape through the hose.

ELECTRICAL CONNECTION

General:

This water heater is designed for single phase 230 - 240V a.c. supply only. The electrical connection must comply with Local Supply Authority Regulations and AS/NZS 3000.

Connection of the electrical wiring must only be carried out by a licensed tradesperson.

The water heater has been designed for connection to a continuous supply tariff or a suitable extended controlled load tariff. Contact Customer Service for more information on

- 1300 412 612 (Australia);
- 0800 081 909 or contact your local Reece branch (New Zealand).

For hard-wired models, the heater is supplied with a 2.5m long power cord which can be connected to a fixed wiring terminal.

A means for disconnection must be incorporated in the fixed wiring in accordance with the Wiring Rules.

Plug-in models are supplied with a 3m power cord to plug into a 10A GPO.

It is highly recommended to add means of cable protection to the power cord to offer protection from gardening equipment, vermin etc.

Cable connection

This unit requires an isolating switch as required by local bylaws.

If the power cord is damaged, it must be replaced by a qualified electrician.

Ensure the water heater is filled with water before turning on the electricity supply.

Warning- Do not replace the heating element with one of a higher heating capacity.

WIRING DIAGRAM

- AT: Ambient temperature
- BTT: Bottom of tank temperature
- COMP: Compressor
- CT: Coil temperature
- EEV: Electronic expand valve
- ET: Exhaust temperature
- FM: Fan motor
- HP: High pressure protection
- SUT: Suction temperature
- TTT: Top of tank temperature
- 4V: 4 way valve
- HT: Heater

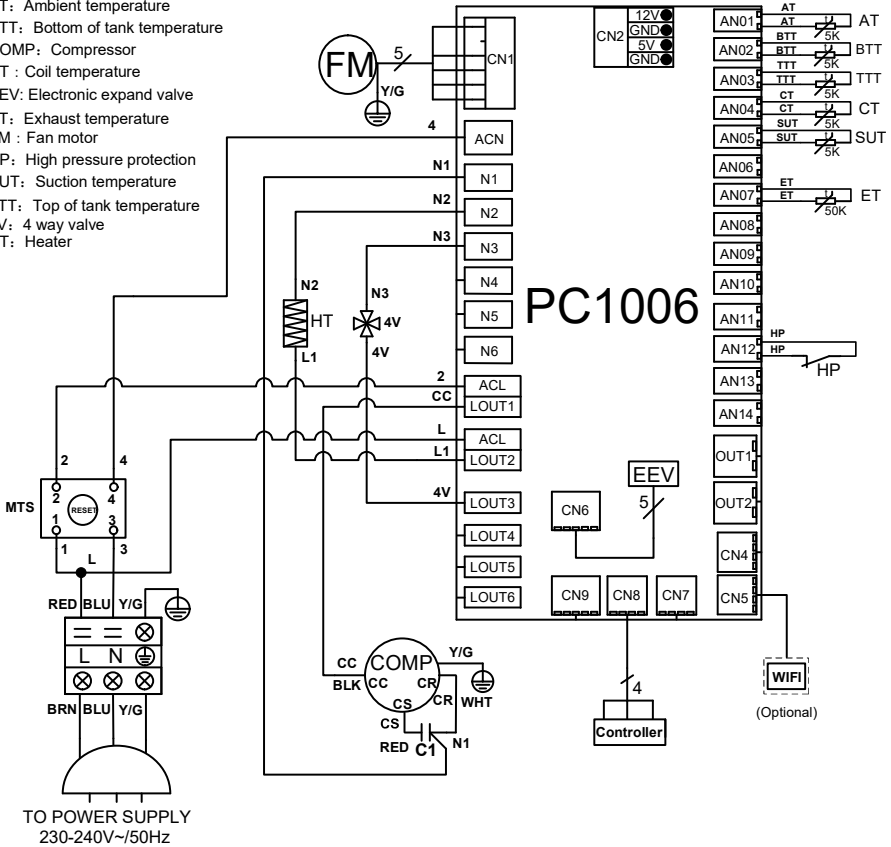

INSTALLATION

For continued safety of this appliance it must be installed, operated and maintained in accordance with the manufacturer's instructions.

If the water supply pressure exceeds the max inlet pressure, a pressure reducing valve is to be fitted when installing the unit.

The water may drip from the discharge pipe of the pressure relief valve and this pipe must be left open to the atmosphere.

The pressure relief valve should be operated regularly to remove lime deposits and verify that it is not blocked.

A discharge pipe connected to the pressure relief valve is to be installed in a continuously downward direction and in a frost-free environment.

Facilities for draining and filling of systems shall be provided where these are required for servicing purposes. The drainage facilities, where fitted, shall be at the lowest point in the closed circuit.

Transportation

The unit is to be stored and/or transported in its packaging in the upright position and without water charge. For transport over a short distance, and provided due care is exercised, an inclination angle of up to 30 degree is permitted. Both during transport and storage, ambient temperatures of 0°C to 40°C are permissible.

Transport using a forklift

When transported by a forklift, the unit must be secured to the pallet.

The lifting height should be kept to a minimum. Due to its top-heaviness, the unit must be secured to prevent tipping over. To prevent any damage, the unit must be placed on a level surface.

Manual transport

For manual transport, the wooden pallet can be used for bottom part.

Care must be taken that the maximum permissible inclination angle of 30 degrees is not exceeded. If transport in an inclined position cannot be avoided, the unit should be placed into operation one hour after it has been moved into final position.

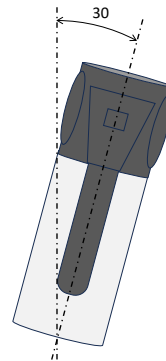

CAUTION High center of gravity!

COMMISSIONING

Initial Operation:

1. Completely fill the water heater with water before turning on the electrical supply. This can be done by opening all hot water outlets in the house and opening the inlet valves to the water heater.



Check the water supply to the tank and pipe connections for possible leaks.

Check that all power connections are secure before switching on.

2. Turn on the electrical supply.

Switch on the unit using the controller.

The parameters have been pre-set to a temperature of 60°C.

3. Press " and hold for 2 seconds in the standby interface of the wired controller to turn on the unit and at this time the main display area shows the water outlet temperature.
4. The fan will start within 5 seconds of pressing "". The compressor will start a minute after the fan turns ON.
5. You may choose to start a one-shot electric heating boost in parallel by pressing " on the display. This will accelerate the heating and will help in achieving the temperature faster.

PRINCIPLE OF OPERATION

Principle of Operation:

A heat pump water heater works in a similar way to a reverse cycle air conditioner. Heat is extracted from the outside air and transferred to the water in the tank. It does not need to be located in direct sunlight to work.

A heat pump water heater can efficiently produce hot water on cloudy and overcast days as well as during the night.

The length of time that the water heater will operate each day will vary depending on the amount of hot water being used and the ambient temperature and humidity.

Generally, the water heater will run longer in winter and at night when the air is cooler due to less heat energy in the air to absorb.

The controller monitors the water temperature and the ambient air temperature. Providing the ambient conditions are suitable, when the water temperature drops, the controller starts the heat pump module to begin heating the water.

Freeze Protection

The water heater is equipped with an active-defrost function which automatically melts ice formed on the evaporator coil during cold ambient conditions.

The water heater also has an anti-freeze function which prevents the water in the tank from icing up during vacation mode.





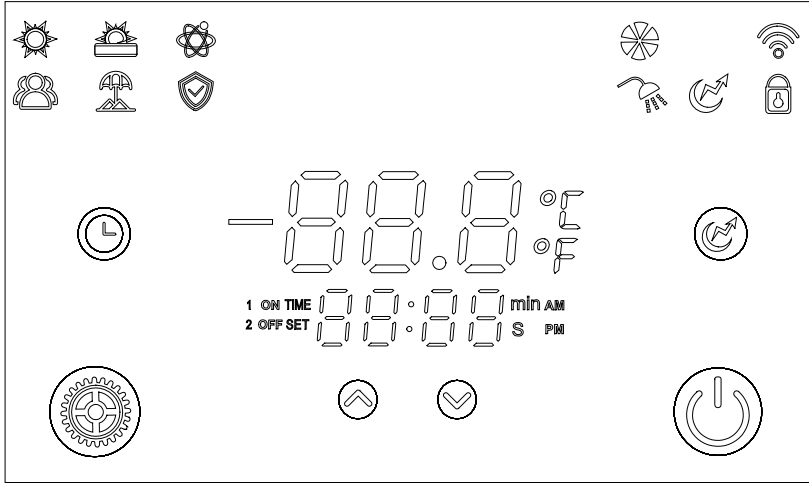

Damage caused by freezing is not covered by the warranty when the water heater is not connected to power.

WARNING: Power must be available to the water heater at all times for the anti-freeze function to work.

DISPLAY OPERATION GUIDE













Function of key

Button	Name	Function
	ON/OFF	Turn on/off the unit
	Mode	Switch unit running modes or save setting parameters
	Clock	Set the clock or the timer
	Electric Heater	Turn on/off the electric heater or switch fan modes
	Upward	Select options to increase values
	Downward	Select options to decrease values
	Eco Heating Mode	Shows that the unit is in heating mode

DISPLAY OPERATION GUIDE

Status Icons

Icon	Name	Function
	Vacation Mode	Shows that the unit is in Vacation Mode
	Standard Heating Mode	Shows that the unit is in heating mode
	Intelligent Mode	Shows that the unit is in Intelligent mode
	High Requirement Mode	Shows that the unit is in High Requirement Mode
	High temperature disinfection	Indicates that the unit is in the high temperature disinfection mode
	Fan	Shows that the fan is on
	Wi-Fi	Indicates Wi-Fi connection
	Set temperature achieved	Shows that the water temperature has reached the target point and the unit will shut off automatically
	Electric Boost mode	Shows that the electric boost mode is on
	Lock	Shows that the keyboard is locked
	Centigrade	Shows that the temperature in main display area in °C

DISPLAY OPERATION GUIDE

Status Icons

Icon	Name	Function
	Fahrenheit	Shows that the temperature in main display area or auxiliary display area is in °F
1 ON 2 OFF	Reserved	Reserved
TIME	Time	Light up when the time is displayed
SET	Parameter setting	Shows that the parameter is adjustable
min	Minute	Shows that the main display area displays the minute
S	Second	Shows that the main display area displays the second
AM	AM	Indicating that the time period is set at 0-12h.
PM	PM	Indicating that the time period is set at 12-24h.

MODE SETTINGS

Turn ON/OFF the unit

To unlock the keyboard, see page 35, "Mode setting - Unlock / lock the keyboard".

Press "⏻" and hold for 2 seconds in the standby interface on the wired controller to turn on the unit and at this time the main display area shows the water outlet temperature.

Press "⏻" and hold for 2 seconds on the interface of the wired controller to turn off the unit and at this time the main display area shows OFF.

Note: The ON/OFF button can only be used to turn on/off the unit in standby or the interface of the wired controller.

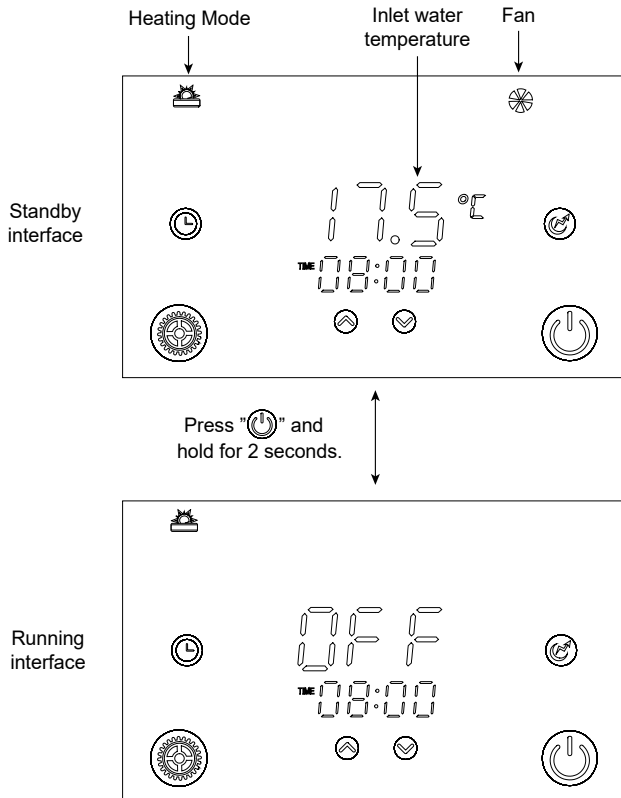

MODE SETTINGS

Mode selection

Press "☀️" to select Standard heating mode, Eco heating mode, Intelligent heating mode, High demand heating mode and Vacation heating mode.

Standard heating mode

The heat pump water heater will start heating the stored water to the target temperature. The heating element will not start immediately. After 250 minutes, the controller will determine if the stored water has reached the target temperature. If it hasn't, the heating element will switch on to help heat the stored water.

Standard heating Mode

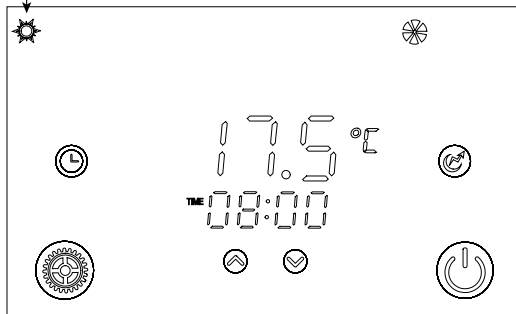

Temperature is adjustable between 60°C and 70°C. If the temperature setting is less than 65°C, the heat pump will heat the tank up to set point (or 60°C if ambient temperature is outside the range of -6°C to 25°C).

If the temperature setting is more than 65°C, the heat pump will heat the tank up to 65°C (60°C if ambient temperature is outside the range of -6°C to 25°C) and the heating element will heat the tank the set point. Once the set temperature is reached, the heat pump will start heating again once the tank temperature drops below 57°C (52°C if the ambient is outside the range of -6°C to 25°C).

MODE SETTINGS

Eco heating mode

The heat pump water heater will heat the stored water to reach the target temperature. The heating element will not switch on unless the ambient is outside the range of -5°C to 43°C .

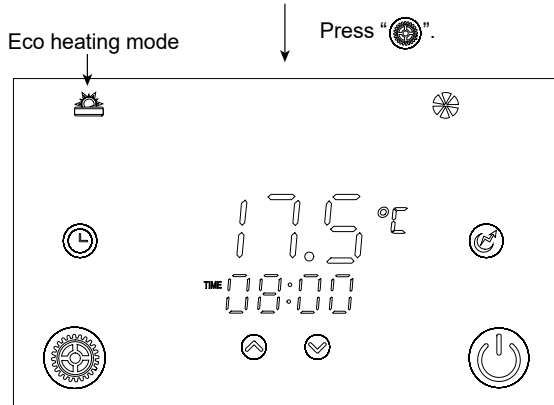

Temperature is adjustable between 60°C and 70°C . If the temperature setting is less than 65°C , the heat pump will heat the tank up to set point (or 60°C if ambient temperature is outside the range of -6°C to 25°C).

If the temperature setting is more than 65°C , the heat pump will heat the tank up to 65°C (60°C if ambient temperature is outside the range of -6°C to 25°C). Since, heating element is not utilised, the maximum temperature achievable in this mode is 65°C . Once the set temperature is reached, the heat pump will start heating again once the tank temperature drops below 57°C (52°C if the ambient is outside the range of -6°C to 25°C).

MODE SETTINGS

Intelligent heating mode

The heat pump will automatically determine which mode best suits the ambient temperature. It will switch between Economy mode, Standard mode and High Demand mode.

When the ambient temperature reaches is above 25°C, the heat pump will enter Eco heating mode.

When the ambient temperature is between -6°C to 25°C, the heat pump will switch to the Standard heating mode. After 250 minutes, the heating element will determine whether to start up according to return differential temperature.

When ambient temp reaches is below -6°C, the heat pump will enter High Demand heating mode, where the heating element will determine whether to start up according to return differential temperature.

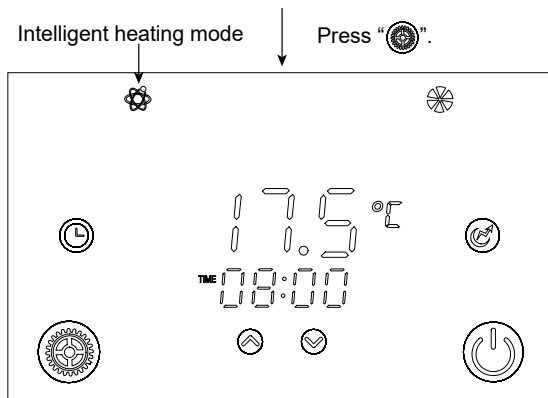

Temperature adjustment and heating behaviour in this mode follows which mode of operation is chosen based on the ambient temperature. Refer to the explanation of corresponding modes.

MODE SETTINGS

High Demand heating mode

The difference between the standard heating mode and the high requirement mode is a 250 minute delay of turning on the heating element.

In the High Demand heating mode, heating element will start without delay, which can help user to heat water quickly in a shorter timeframe.

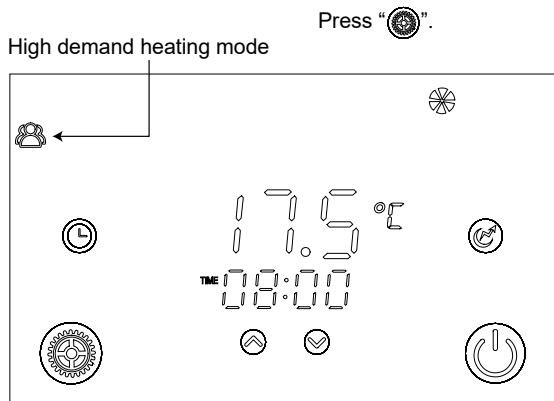

Temperature is adjustable between 60°C and 70°C. If the temperature setting is less than 65°C, the heat pump and heating element together will heat the tank up to set point (or 60°C if ambient temperature is outside the range of -6°C to 25°C).

If the temperature setting is more than 65°C, the heat pump and heating element together will heat the tank up to 65°C (60°C if ambient temperature is outside the range of -6°C to 25°C) and the heating element will heat the tank the set point.

Once the set temperature is reached, the heat pump and heating element will start heating again once the tank temperature drops below 57°C (52°C if the ambient is outside the range of -6°C to 25°C).

MODE SETTINGS

Vacation mode

When selecting Vacation mode, you need to set a vacation time. The unit will keep operating in the set mode prior to the scheduled vacation time. Once it has reached the end of the vacation time, the heat pump will exit the vacation mode and run in it's previous mode.

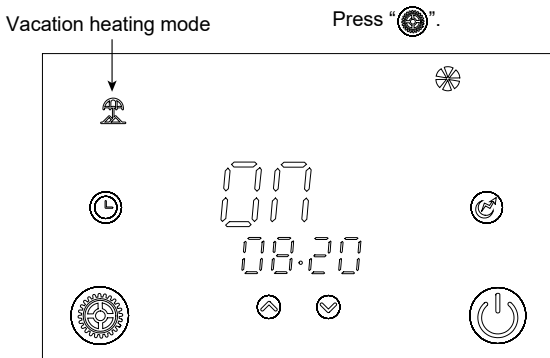

Instructions on how to set up Vacation mode can be found on the next page.

MODE SETTINGS

Vacation mode

On departure day, activate the Vacation mode by turning off the water heater at the controller and follow the instructions below to set the "Turn back ON" date.

Press "⌚" and hold for 2 seconds to enter the timer setting interface. The date parameter will start to flash. Then set the date in the same way as "Set date & time" found on page 26.

Example: Set the "Turn back ON" date for September 28 (Note : Don't forget to turn the unit off before going on vacation).

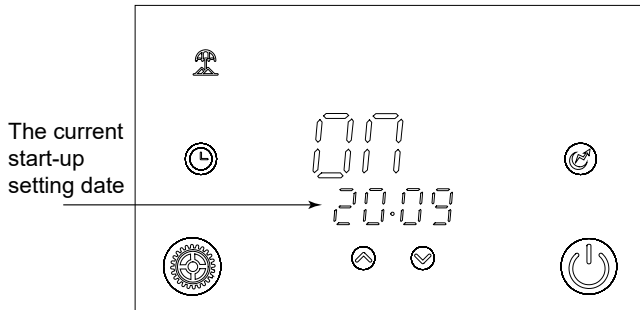

Press "⌚" and hold for 2s, then press "↑" or "↓" to set the date to September 28 and press "⌚" to confirm.

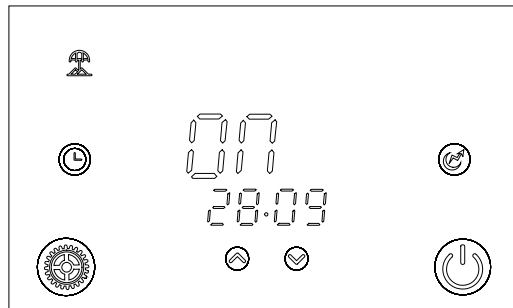

MODE SETTINGS

Boost mode

The Boost mode turns the heating element on for only one heating cycle when the unit is heating or on standby.

Press "⏻" once to turn on the electric heating element and press "⏻" again to turn it off.

Boost heating mode

When the unit is turned off, pressing "⏻" will turn on the boost heating mode.

At this time, the "⏻" is lit up, and the main display area shows "OFF" and the outlet water temperature. Short press "⏻" again to turn off the boost heating mode, and the main display area will still show "OFF".

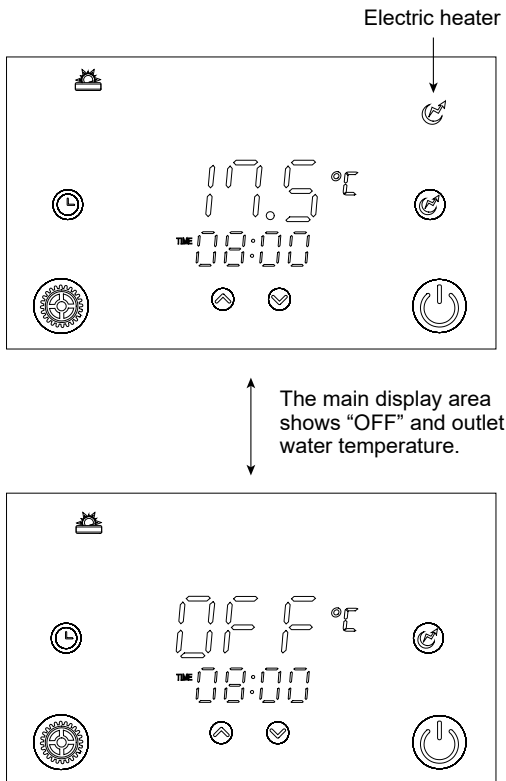

TEMPERATURE SETTINGS

Target temperature checking and setting

In the standby or running interface, press "▲" or "▼" once to check the target temperature of the outlet water. Press "▲" or "▼" again to change the target temperature. After making the changes to the parameter, press "⊙" to confirm or "⏻" to cancel the changes, then return to the previous interface. If no operations are performed on the keypad for 15 seconds, the controller exits the parameter modification menu by timeout and the changes are confirmed.

Example: Change the target temperature from 60°C to 65°C when the actual outlet water temperature is 17.5°C.

After setting the temperature, the controller detects through the temperature sensing that the internal temperature of the water tank has reached the set temperature, and then controls the entire machine to stop heating. The lower the target temperature setting, the more economical it is.

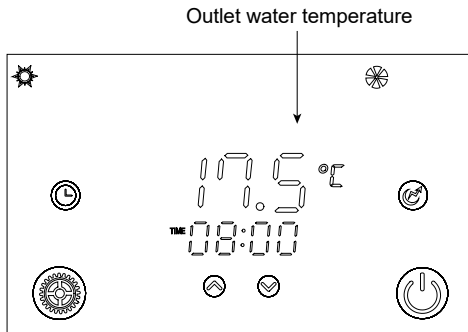

TEMPERATURE SETTINGS

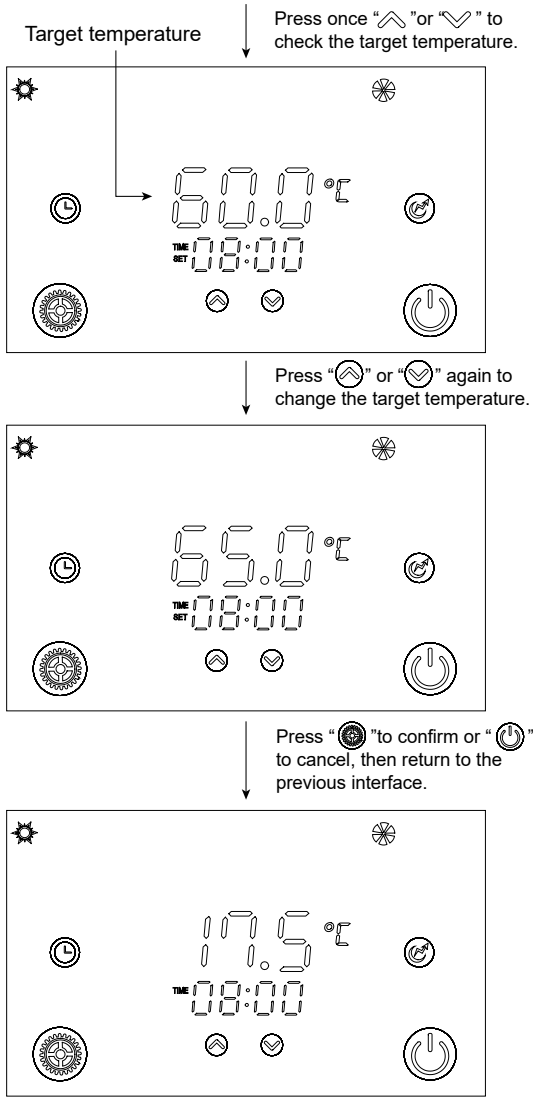

DATE & TIME SETTINGS

Set date & time

The following instructions allow you to set the date and time. Press "⌚" once and the hour parameter will flash, then press "⬆️" or "⬇️" to change it. After making the changes to the parameter, press "⌚" to confirm, then change the minute parameter as well as the date parameter in the same way.

If no operations are performed on the keypad for 15 seconds, the controller will exit the parameter modification menu by timeout and the changes are confirmed.

Note: Set the date in the same way when in vacation mode.

Example: Change the time and date from 18:30 on August 4th to 17:40 on September 8th.

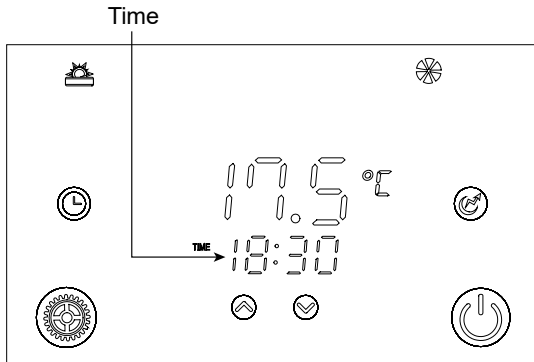

Press "⌚" once then press "⬆️" or "⬇️" to change the hour parameter and press "⌚" to confirm.

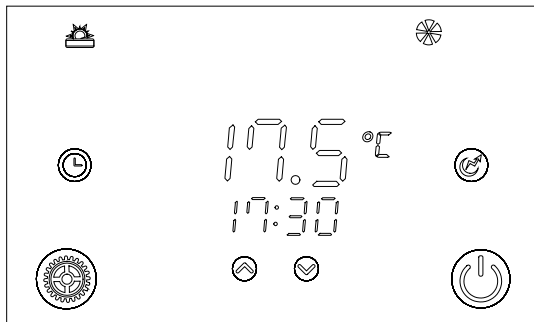

DATE & TIME SETTINGS

↓ Press “▲” or “▼” to change the minute parameter.

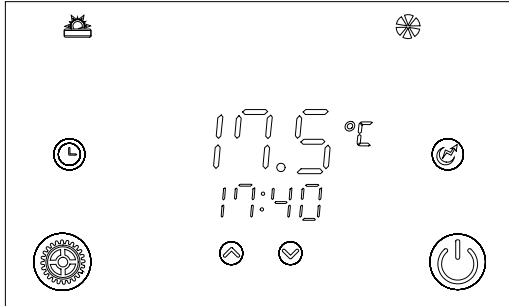

The date is flashing ↓ Press “⊙” to confirm.

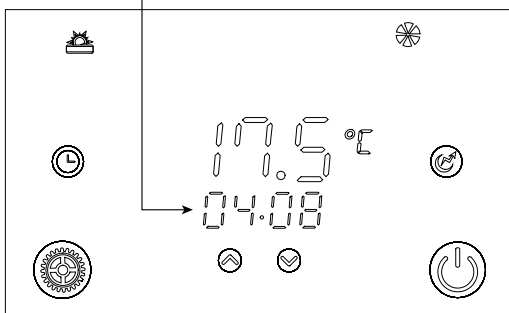

↓ press “▲” or “▼” to change the day parameter and press “⊙” to confirm.

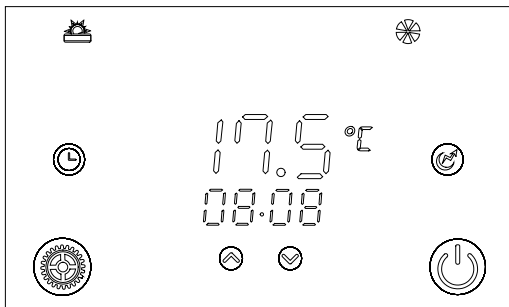

DATE & TIME SETTINGS

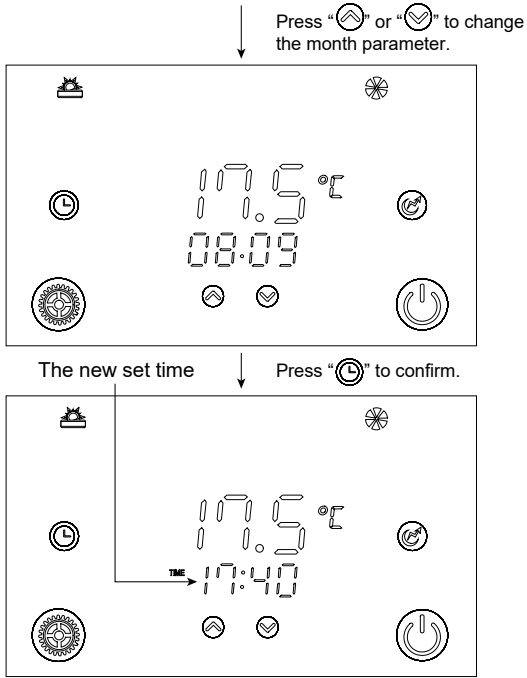

TIMER SETTINGS

Timer setting

You can set up to two timers when the heat pump is in the Heating mode.

Press "⌚" and hold for 2 seconds, the "1 and ON" will flash, and then you can set the turn on time of timer1 as the "Set time & date" section shows. After finishing, "1 and OFF" will flash, that means you can set the turn off time for timer1.

The "2 and ON" will flash after finishing the timer1 setting, you can set the turn on time for timer2. After finishing, the "2 and OFF" will flash, and then you can set the turn off time for timer2. Press "⌚" again to save and go back to the interface.

If you don't need to set the timer2, you can press the "⌚" to save after finishing the timer1 setting. You will find the "2 and ON" will flash. Wait for 15 seconds with no operation, the program will revert back to the interface automatically.

Note: You can sequentially press "⌚" for 2 seconds to enter the turn off time for timer1 or timer2. Or press "⬆" or "⬇" to rotate through the display.

Timer Cancel: Press "⌚" and hold for 2 seconds to enter the interface, and then press "⏻" to cancel the operation.

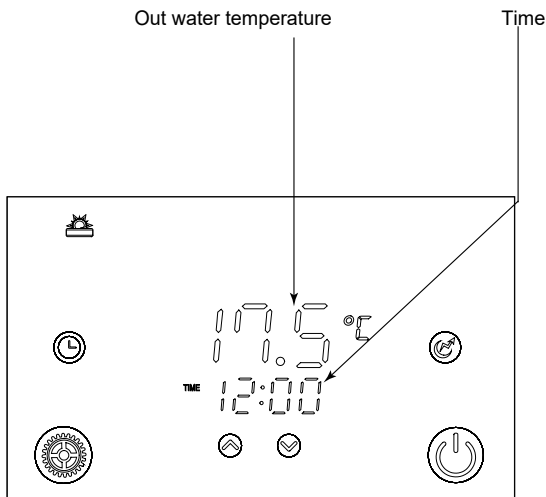

TIMER SETTINGS

Period 1 ON time ↓ Press "⌚" and hold for 2S

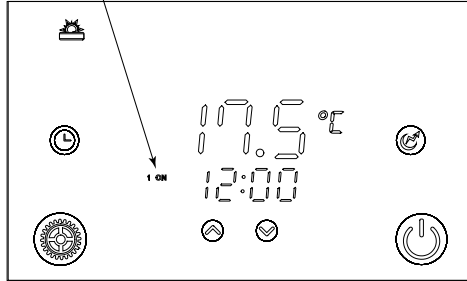

Press "⌚" and hold for 2 seconds to enter into the next setting without confirm the previous one.

Period 1 OFF time

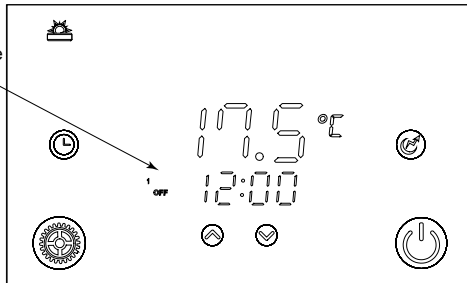

Press "⌚" and hold for 2 seconds to enter into the next setting without confirm the previous one.

Period 2 ON time

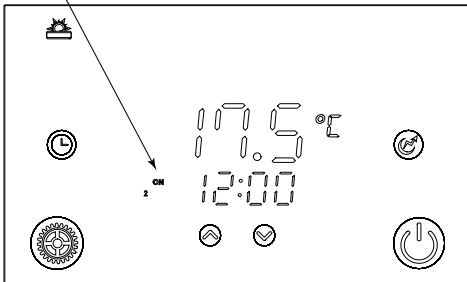

Press "⌚" and hold for 2 seconds to enter into the next setting without confirm the previous one.

TIMER SETTINGS

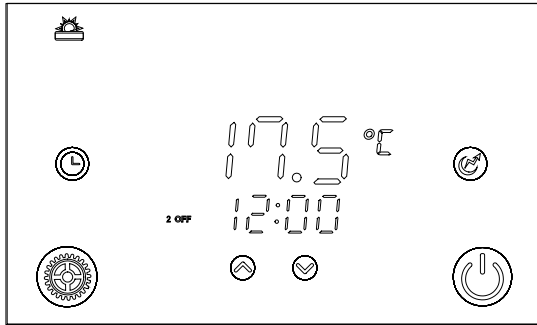

Set the hour

Period 2 OFF time

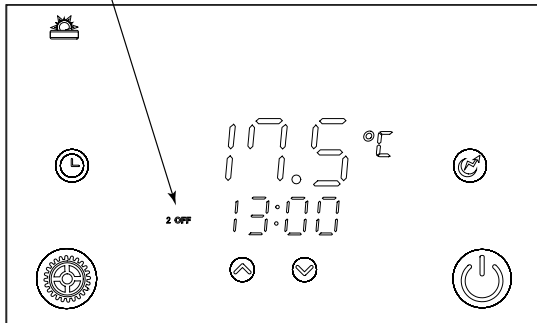

Set the minute



TIMER SETTINGS

↓ Press “⌚” to confirm the time

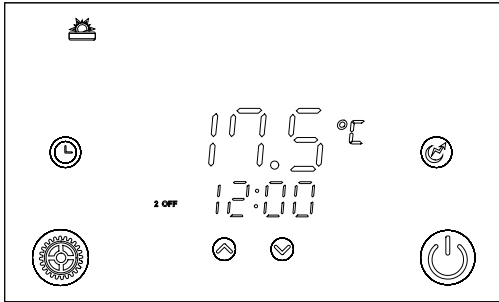

Example: Running period 1: 8:00~10:00; Running period 2: 16:30~20:00.

Out water temperature Current time

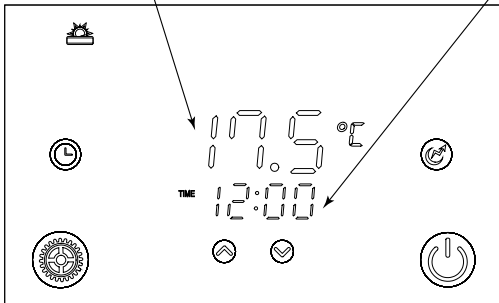

↓ Press “⌚” and hold for 2S



TIMER SETTINGS

↓ Confirm the time after setting
Period 1 OFF time

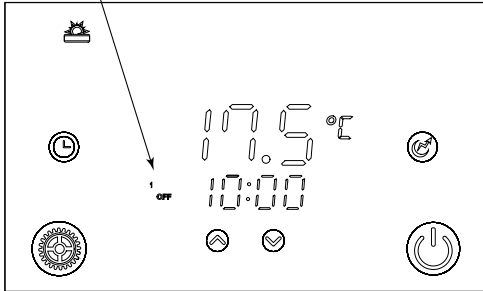

↓ Confirm the time after setting
Period 2 ON time

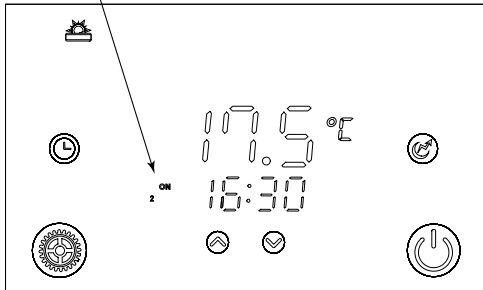

↓ Confirm the time after setting

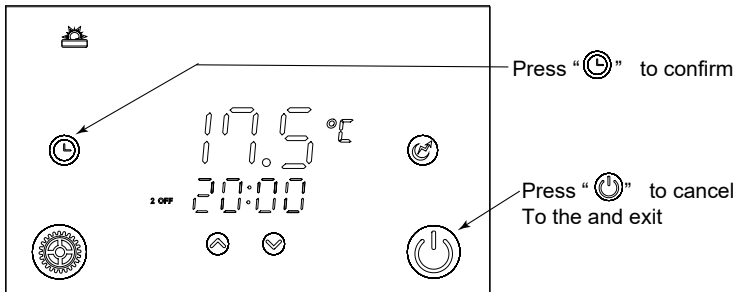

TIMER SETTINGS

To cancel the timer setting:

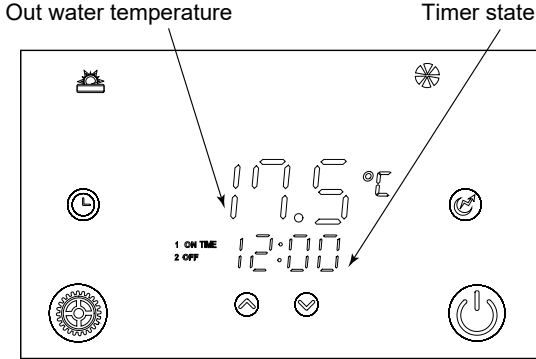

The "1 ON" icon and time are flashing

Press "⌚" and lasting for 2s

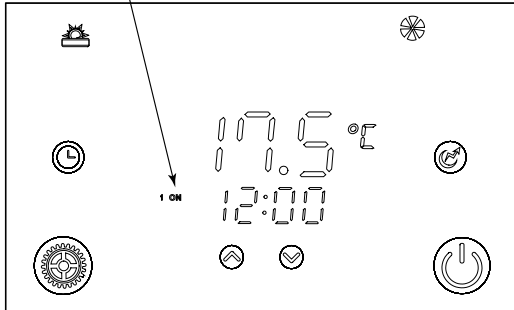

Press "⏻" to cancel all the operation

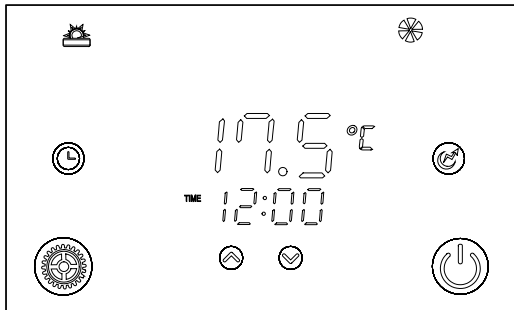

LOCK SETTINGS

Unlock / lock the keyboard

Press "⏻" and hold for 5 seconds to unlock the keyboard. Press "⏻" and hold for 5 seconds again to lock the keyboard.

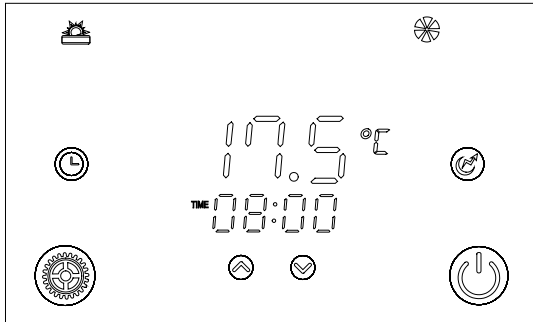

↑ ↓ Press "⏻" and hold for 5s.

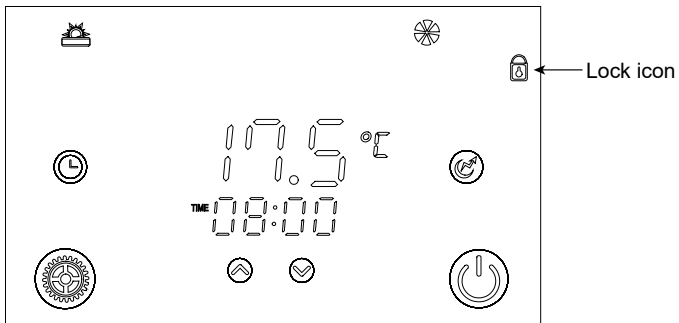

Forced Defrost

Pressing and holding the "⏻" for 10 seconds turns on the forced defrost function. After pressing the "⏻" button, the "🔒" icon turns on and then turns off. Then the compressor starts defrosting without the fan operating.

SYSTEM MAINTENANCE

Anode Replacement:

The water heater is equipped with two anodes.

Follow these steps to replace the Long Vertical anode;

1. Ensure that any electrical supply to the water heater is disconnected.
2. Close the isolating valve on the cold water inlet and release any pressure in the water heater by lifting the lever on the PTR valve.
3. Remove the front cover holding the display, by removing the 4 screws holding it against the case and pulling it up.
4. Flip the front cover carefully and keep lifting. Remove the display unit by removing the 6 screws.
5. Remove the fan guard by removing the 3 screws. *Don't remove the cover for the other side.
6. Remove the top cover by removing the 4 screws.
7. Remove the PCB kit by removing 3 screws. *Don't need to remove the plastic cover for PCB.
8. Remove the rubber lid and replace the anode by using 19mm socket wrench.
9. Re-install all the items by reversing the procedure above and connect the power to the water heater.

Follow these steps to replace the Short Horizontal anode;

- a) Follow the same step as the Long Vertical instructions for steps 1 and 2.
- b) Drain some hot water by opening the valve marked "DRAINAGE". *There is no need to drain the whole tank.
- c) Replace the anode located below the hot water outlet and marked "Mg. ANODE". *Be careful not to get scalded as hot water may flow out of the tank if it's not drained to below the anode connection point.

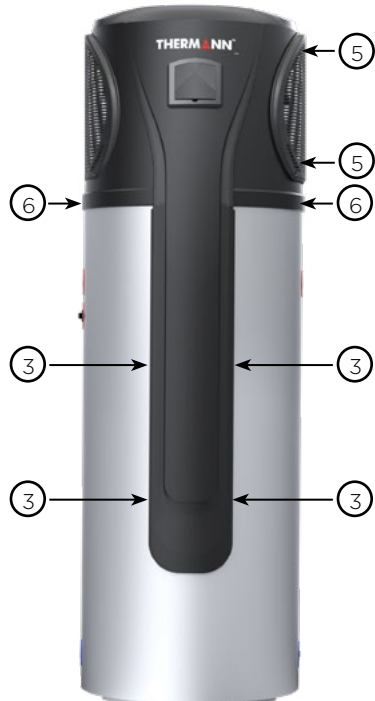

SYSTEM MAINTENANCE

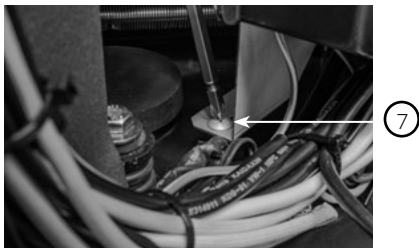
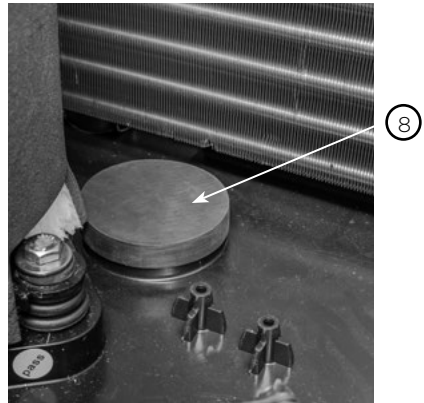
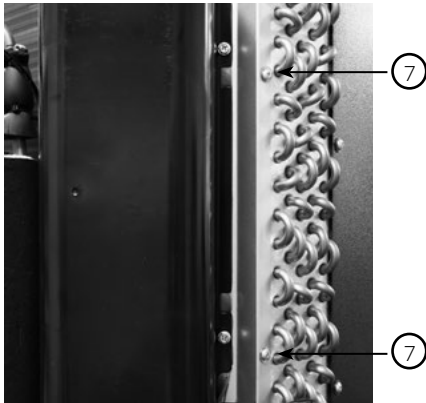
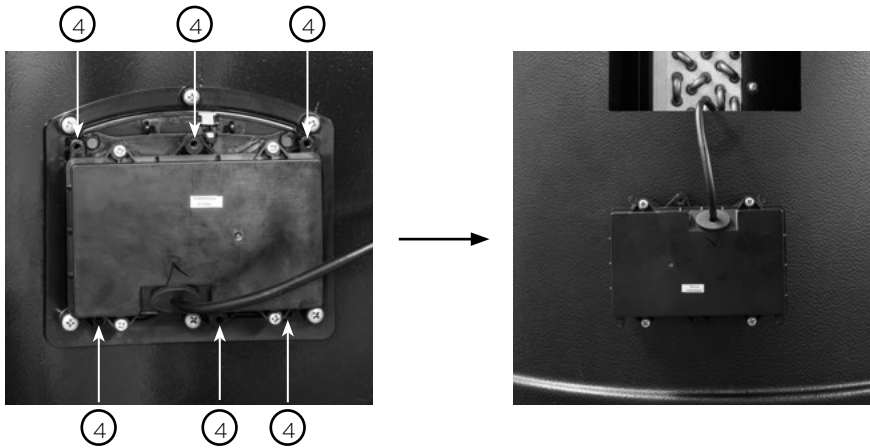

SYSTEM MAINTENANCE

Regular servicing will help to extend the life of the water heater, and keep it operating safely and efficiently.

The conditions applying to your water heater warranty are set out on page 48 of this manual.

Six Month Service:

This service may be carried out by the owner.

1. Stand clear of the Pressure & Temperature Relief (PTR) Valve drain pipe outlet.
2. Open the PTR Valve for approximately 10 seconds by lifting the easing lever on the valve. Confirm water discharges to waste through the drain pipe.
3. Lower the easing lever gently and check it closes correctly.
4. Repeat the above process for the expansion control valve (if installed).
5. Check that the grill on top of the water heater and the louvres are free of debris or other obstructions.

Other than this, personally inspecting or servicing any part of the water heater is not recommended.

Five Year Service:

This service should only be carried out by a licensed tradesperson.

In locations where the water has Total Dissolved Solids (TDS) exceeding 600mg/L, this service is recommended every 3 years.

This service should include the following:

- Replace the PTR Valve.
- Replace both anodes.
- Inspect and flush the expansion control valve (if installed).
- Clean any debris or residue from the condensate gutter and confirm that the condensate drain line is clear.
- Clean any dust or build up from the evaporator and louvres.
- Clean the fan blades and grill.

Drain and flush the water heater.

Replacement parts are available from your local Reece branch.

TROUBLESHOOTING

1. Why is the compressor not running when I start up the heat pump?

When the heat pump is powered on after the last shut-down, it will take 3 minutes for the compressor to run. This is to protect the unit.

2. Why does the outlet water temperature slowly increase on the display?

On start up, the water temperature is different at the base and at the top of the tank. When the stored water is all at the same temperature, it will warm the water faster.

3. Why does the outlet water temperature on the display decrease when the heat pump is in heating mode?

If the water temperature at the top of the tank is much higher than the water at the bottom, the water temperature will decrease a little because of the convection between hot water and cold water in the tank.

4. Why does the heat pump not start to heat immediately when the outlet water temperature decreases?

The water temperature will decrease because of the heat loss from the tank when not used for a long time. In order to avoid the continual ON/OFF, the unit does not start up until the water temperature decreases by more than a few degrees.

5. Why does the outlet water temperature suddenly decrease?

The water in the tank can have different temperatures.

The cold water may reach the upper sensor when the hot water has been used up.

6. Why is hot water still available when the water out temperature on the display decreases substantially?

Because the upper sensor is positioned near the top of the tank, where $\frac{1}{5}$ of hot water is available.

The displayed temperature reduces as the outlet water temperature reduces.

7. Why is the heating time so long?

The heat pump operates by drawing heat from the ambient air, saves energy and has low power consumption. The average heating time is 2-6 hours depending on the inlet water temperature, water consumption and the ambient temperature.

TROUBLESHOOTING

Common error codes and corrective actions are described below.

Call Customer Service if required on

- 1300 412 612 (Australia);
- 0800 081 909 or contact your local Reece branch (New Zealand).

Display	Error Description	Corrective action
P01	Bottom water temperature sensor failure (sensor is open or short circuit)	Check or change the tank bottom temperature sensor.
P02	Top tank water temperature sensor failure (sensor is open or short circuit)	Check or change the tank top tank temperature sensor.
P03	Discharge temperature sensor failure (sensor is open or short circuit)	Check or change the discharge temperature sensor.
P04	Ambient temperature sensor failure (sensor is open or short circuit)	Check or change the ambient temperature sensor
P05	Coil temperature sensor failure (sensor is open or short circuit)	Check or change the pipe temperature sensor
P07	Suction temperature sensor failure (sensor is open or short circuit)	Check or change the suction temperature sensor.
P82	Discharge overheating protection	Check if the refrigerant system has leak points or is blocked.
E01	High pressure protection (The exhaust pressure is high, high pressure switch action)	Check the high pressure switch or check if the refrigerant system is blocked.
E08	Communication failure (Wired remote control with master signal failure)	Check the connection line between the wired remote control and motherboard.
E09	Winter frost protection	The water temperature is too low, please pay attention to anti-freezing.
E11	DC motor stalling	Check the motor and its connector.
E43	High pressure switch three times protection	Check the high pressure switch or check if the refrigerant system is blocked
E45	Discharge overheating three times protection	Check if the refrigerant system has leak points or is blocked.

CONSIDERING A SERVICE CALL?

Please review this section. Although there are no user serviceable components in the water heater, the information contained in this section may enable you to avoid the cost of a service call.

Please do not remove any covers or attempt to make any adjustments.

Water Discharge from Condensation Drain Line:

Water may be expected to drain from the Condensate Drain Line when the water heater is operating. This is similar to the condensation produced by an air conditioner. The amount of condensation produced will depend on ambient conditions such as temperature and humidity.

No Hot Water:

Ensure the power supply circuit breaker has not "tripped". If the water heater is connected to a controlled load tariff, ensure this is operating correctly.

Ensure that timers are not set to limit the heating duration for the unit.

Ensure that there are no errors displayed on the controller display.

High Energy Bills or Insufficient Hot Water:

- Often the hot water usage of showers, washing machines and dishwashers can be under estimated. Review these appliances to determine if the daily usage is greater than the capability of the water heater.
- If necessary check the shower flow rates with a bucket, measuring the

amount of water used over a period of time. If it is not possible to adjust water usage patterns, an inexpensive flow control valve can easily be fitted to the shower outlet.

- Check that the grills on the sides of the water heater are free of debris or other obstructions.
- The water heater may take longer to reheat during the night or the colder months as the air is usually cooler. It is possible that the water heater may not fully recover from a period of heavy usage during the previous day. Consider using the Boost mode to reheat the water faster.
- Is there a leaking hot water pipe or dripping hot water tap? A small leak can waste a large quantity of hot water. Replace faulty tap washers and arrange for your plumber to rectify any leaking pipe work.
- Is the Pressure & Temperature Relief Valve discharging too much water?
See below.

Continuous Trickle of Water from Pressure & Temperature Relief (PTR) Valve:

This is most likely due to a build up of foreign matter. In this case, try gently raising the easing lever on the PTR Valve for a few seconds, then release gently.

This may dislodge a small particle of foreign matter and rectify the fault.

CONSIDERING A SERVICE CALL?

Water Discharge from PTR Valve:

It is not unusual for a small quantity of water to discharge during the heating of water in the storage tank. The amount of discharge will depend on hot water usage and the size of the storage tank.

As a guide, it will discharge about 2% of the volume of the water heated.

Continuous leakage of water from the PTR Valve may indicate a problem with the water heater. Turn off the water heater and contact Customer Service

- 1300 412 612 (Australia);
- 0800 081 909 or contact your local Reece branch (New Zealand).

If the water supply pressure exceeds the maximum inlet water pressure, a pressure reducing valve has to be fitted to the installation.

If after checking the above points, the problem has not been identified, please consult Customer Service:

- ***1300 412 612 (Australia);***
- ***0800 081 909 or contact your local Reece branch (New Zealand).***

SERVICE & DECOMMISSIONING

ANY REFRIGERATION WORK MUST ONLY BE UNDERTAKEN BY APPROPRIATELY LICENSED TRADESPERSONS.

Checks to the area

Prior to beginning work on systems containing flammable refrigerants, conduct safety checks to ensure that the risk of ignition is minimised.

Work procedure

Work shall be undertaken under a controlled procedure so as to minimise the risk of a flammable gas or vapour being present while the work is being performed.

All maintenance staff and others working in the local area shall be instructed on the nature of work being carried out. Work in confined spaces shall be avoided.

Checking for presence of refrigerant

The area shall be checked with an appropriate refrigerant detector prior to and during work, to ensure the technician is aware of potentially toxic or flammable atmospheres. Ensure that the leak detection equipment being used is suitable for use with all applicable refrigerants, i.e. non-sparking, adequately sealed or intrinsically safe.

Presence of fire extinguisher

If any hot work is to be conducted on the refrigerating equipment or any associated parts, appropriate fire extinguishing equipment shall be available to hand. Have a dry powder

or CO₂ fire extinguisher adjacent to the charging area.

No ignition sources

No person carrying out work in relation to a **refrigerating system** which involves exposing any pipe work shall use any sources of ignition in such a manner that it can lead to the risk of fire or explosion.

All possible ignition sources, including cigarette smoking, should be kept sufficiently far away from the site of installation, repairing, removing and disposal, during which refrigerant can possibly be released to the surrounding space. Prior to work taking place, the area around the equipment is to be surveyed to make sure that there are no flammable hazards or ignition risks. "No Smoking" signs shall be displayed.

Ventilated area

Ensure that the area is in the open or that it is adequately ventilated before breaking into the system or conducting any hot work. A degree of ventilation shall continue during the period that the work is carried out. The ventilation should safely disperse any released refrigerant and preferably expel it externally into the atmosphere.

SERVICE & DECOMMISSIONING

Checks to the refrigerating equipment

Where electrical components are being changed, they shall be fit for the purpose and to the correct specification. At all times the manufacturer's maintenance and service guidelines shall be followed. If in doubt, consult the manufacturer's technical department for assistance.

Checks to electrical devices

Repair and maintenance to electrical components shall include initial safety checks and component inspection procedures. If a fault exists that could compromise safety, then no electrical supply shall be connected to the circuit until it is satisfactorily dealt with. If the fault cannot be corrected immediately but it is necessary to continue operation, an adequate temporary solution shall be used. This shall be reported to the owner of the equipment so all parties are advised.

Initial safety checks shall include:

- that capacitors are discharged: this shall be done in a safe manner to avoid possibility of sparking;
- that no live electrical components and wiring are exposed while charging, recovering or purging the system;
- that there is continuity of earth bonding.

Sealed electrical components

Sealed electrical components shall not be repaired.

Cabling

Check that cabling will not be subject to wear, corrosion, excessive pressure, vibration, sharp edges or any other adverse environmental effects. The check shall also take into account the effects of aging or continual vibration from sources such as compressors or fans.

Detection of flammable refrigerants

Under no circumstances shall potential sources of ignition be used in the searching for or detection of refrigerant leaks. A halide torch (or any other detector using a naked flame) shall not be used.

The following leak detection methods are deemed acceptable for all refrigerant systems.

Electronic leak detectors may be used to detect refrigerant leaks but, in the case of flammable refrigerants, the sensitivity can be inadequate, or can need re-calibration. (Detection equipment shall be calibrated in a refrigerant-free area.) Ensure that the detector is not a potential source of ignition and is suitable for the refrigerant used. Leak detection equipment shall be set at a percentage of the LFL of the refrigerant and shall be calibrated to the refrigerant employed, and the

SERVICE & DECOMMISSIONING

appropriate percentage of gas (25% maximum) is confirmed.

Leak detection fluids are also suitable for use with most refrigerants but the use of detergents containing chlorine shall be avoided as the chlorine can react with the refrigerant and corrode the copper pipe-work.

NOTE Examples of leak detection methods are

- bubble method,
- fluorescent agent method.

If a leak is suspected, all naked flames shall be removed/extinguished.

If a leakage of refrigerant is found which requires brazing, all of the refrigerant shall be recovered from the system, or isolated (by means of shut-off valves) in a part of the system remote from the leak.

Refrigerant removal and circuit evacuation

For **flammable refrigerants** it is important that best practice is followed when breaking into the refrigerant circuit to make repairs or for any other purpose since flammability is a consideration. The following procedure shall be adhered to:

- safely remove refrigerant following local and national regulations;
- evacuate;
- purge the circuit with inert gas;
- evacuate;

- continuously flush with inert gas when using flame to open circuit;
- open the circuit.

The **refrigerant charge** shall be recovered into the correct recovery cylinders.

Compressed air or oxygen shall not be used for purging refrigerant systems.

NOTE An example of an inert gas is dry nitrogen.

Purging of the refrigerant circuit shall be achieved by breaking the vacuum in the system with inert gas and continuing to fill until the working pressure is achieved, then venting to atmosphere, and finally pulling down to a vacuum. This process shall be repeated until no refrigerant is within the system. The system shall be vented down to atmospheric pressure to enable work to take place.

Ensure that the outlet of the vacuum pump is not close to any potential ignition sources and that ventilation is available.

Charging procedures

In addition to conventional charging procedures, the following requirements shall be followed.

- Ensure that contamination of different refrigerants does not occur when using charging equipment. Hoses or lines shall be as short as possible to minimise the amount of refrigerant contained in them.

SERVICE & DECOMMISSIONING

- Cylinders shall be kept in an appropriate position according to the instructions.
- Ensure that the refrigerating system is earthed prior to charging the system with refrigerant.
- Label the system when charging is complete (if not already labelled).
- Extreme care shall be taken not to overflow the **refrigerating system**.

Prior to recharging the system, it shall be pressure-tested with the appropriate purging gas. The system shall be leak-tested on completion of charging but prior to commissioning. A follow up leak test shall be carried out prior to leaving the site.

Decommissioning

Before carrying out this procedure, it is essential that the technician is completely familiar with the equipment and all its detail. It is recommended good practice that all refrigerants are recovered safely. Prior to the task being carried out, an oil and refrigerant sample shall be taken in case analysis is required prior to re-use of recovered refrigerant. It is essential that electrical power is available before the task is commenced.

- 1) Become familiar with the equipment and its operation.
- 2) Isolate system electrically.
- 3) Before attempting the procedure, ensure that:
 - a) mechanical handling equipment

is available, if required, for handling refrigerant cylinders;

- b) all personal protective equipment is available and being used correctly;
 - c) the recovery process is supervised at all times by a competent person;
 - d) recovery equipment and cylinders conform to the appropriate standards.
- 4) Pump down refrigerant system, if possible.
 - 5) If a vacuum is not possible, make a manifold so that refrigerant can be removed from various parts of the system.
 - 6) Make sure that the cylinder is situated on the scales before recovery takes place.
 - 7) Start the recovery machine and operate in accordance with instructions.
 - 8) Do not overfill cylinders (no more than 80% volume liquid charge).
 - 9) Do not exceed the maximum working pressure of the cylinder, even temporarily.
 - 10) When the cylinders have been filled correctly and the process completed, make sure that the cylinders and the equipment are removed from site promptly and all isolation valves on the equipment are closed off.
 - 11) Recovered refrigerant shall not be charged into another refrigerating

SERVICE & DECOMMISSIONING

system unless it has been cleaned and checked.

Labelling

Equipment shall be labelled stating that it has been de-commissioned and emptied of refrigerant. The label shall be dated and signed.

Recovery

When removing refrigerant from a system, either for servicing or decommissioning, it is required to follow good practice so that all refrigerants are removed safely.

When transferring refrigerant into cylinders, ensure that only appropriate refrigerant recovery cylinders are employed. Ensure that the correct number of cylinders for holding the total system charge is available. All cylinders to be used are designated for the recovered refrigerant and labelled for that refrigerant (i.e. special cylinders for the recovery of refrigerant). Cylinders shall be complete with pressure-relief valve and associated shut-off valves in good working order.

Empty recovery cylinders are evacuated and, if possible, cooled before recovery occurs.

The recovery equipment shall be in good working order with a set of instructions concerning the equipment that is at hand and shall be suitable for the recovery of the **flammable refrigerant**.

Consult manufacturer if in doubt. In addition, a set of calibrated weighing scales shall be available and in good working order. Hoses shall be complete with leak-free disconnect couplings and in good condition.

The recovered refrigerant shall be processed according to local legislation in the correct recovery cylinder, and the relevant waste transfer note arranged. Do not mix refrigerants in recovery units and especially not in cylinders.

If compressors or compressor oils are to be removed, ensure that they have been evacuated to an acceptable level to make certain that **flammable refrigerant** does not remain within the lubricant. The compressor body shall not be heated by an open flame or other ignition sources to accelerate this process. Draining of oil from a system shall be carried out safely.

WARRANTY

Thermann 270L Heat Pump Water Heater - Warranty Summary:

Your water heater is specified with a warranty as set out in the table below.

The fault must appear within the defined time period, which commences from the date of installation (or manufacturing date of the unit if proof of the date of installation is not available) in order to be covered.

Thermann 270L Heat Pump Water Heater Warranty [#]		Tank Warranty*	Refrigeration Component ¹ Warranty	Other Components ² Warranty
Single Family Dwelling	Parts	5 years	5 years	1 year
	Labour	5 years	5 years	1 year
All Other Applications	Parts	3 years	3 years	1 year
	Labour	1 year	1 year	1 year

(1) Refrigeration Components include but are not limited to: compressor, condenser, expansion valve, heat exchanger, evaporator and associated pipe work. (2) Other Components include but are not limited to: sensors, thermostats, valves, electric heating elements, anodes.* Inner Storage Cylinder.

The benefits provided to you by this warranty are in addition to any other rights #Where an incentive is being applied for under the Victorian Energy Upgrades (VEU) Program, through the Solar Victoria's Solar Home Program or NSW Energy Savings Scheme (ESS), a separate warranty applies. See page 49.

Other Components² Warranty:

Dux Manufacturing Limited ("Dux") warrants against defects in the water heater arising from faulty materials or workmanship.

During the period (as specified in the table above), Dux will repair or replace any failed component² free of charge including reasonable labour costs incurred during normal business working hours.

Refrigeration Component¹ Warranty:

Dux warrants against failure of refrigeration components¹ arising from faulty materials or workmanship (as specified in the table above).

During this period Dux will repair or replace any failed refrigeration component free of charge including reasonable labour costs incurred during normal business working hours.

Tank Failure Warranty:

Dux warrants against failure of the storage tank, in accordance with its application (as specified in the table above). Conditions apply.

During the period of coverage (as specified in the table above), Dux will repair or replace the tank free of charge including reasonable labour costs incurred during normal business working hours.

WARRANTY

Victorian Energy Upgrades (VEU) Warranty:

Without limiting the periods shown in the table on page 48, a 5 year product warranty applies where Victorian Energy Efficiency Certificates (VEECs) have been created for an eligible water heater installation activity (activity 1, 3 or 44) when installed from 1st February 2025.

For further details call 1300 412 612. Proof of VEEC assignment is required to be provided at the time of booking the service call.

Solar Victoria's Solar Home Program Warranty:

Without limiting the periods shown in the table on page 48, a 5 year 'Whole of Product' warranty applies where a rebate has been received under Solar Victoria's Solar Homes Program for a water heater installed from 1st July 2023.

The 5 year 'Whole of Product' warranty will also include labour coverage for installations from 1st September 2025.

For further details call 1300 412 612. Rebate proof of receipt is required to be provided at the time of booking the service call.

NSW Energy Savings Scheme (ESS) Warranty:

Without limiting the periods shown in the table on page 48, a warranty against defects covering at least five years from the date of installation, purchase or

supply is applicable where NSW Energy Savings Scheme (ESS) Certificates have been created for an eligible water heater installation activity from 1st December 2025.

For further details call 1300 412 612. Proof that NSW Energy Savings Certificates (ESCs) were created for the heat pump installation are required to be provided at the time of booking the service call.

Warranty Conditions:

The warranty only applies to the water heater itself and the components supplied with the water heater by Dux. The warranty does not cover components including non-genuine spare parts supplied by others, including the installer.

Dux may reject a claim under this warranty in its sole discretion if a third party solar diverter is connected to the water heater.

The tank failure warranty does not apply if the water heater has been connected to a water supply where the Total Dissolved Solids (TDS) content is greater than 2500mg/L.

For TDS between 600mg/L and 2500mg/L, a hard water version with Aluminium anodes must be used. Warranty does not apply for heaters with Magnesium anodes when TDS is greater than 600mg/L

Warranty also does not apply if the Saturation Index (LSI) is less than -1.0 or greater than +0.8. LSI figures

WARRANTY

stated above are calculated with a water temperature of 80°C.

These warranties do not apply to defects that are a result of, without limitation, the following:

- failure to install the water heater in accordance with the installation instructions or statutory requirements;
- faulty plumbing or water supply including excessive pressure;
- faulty power supply;
- damage caused by freezing is not covered by the warranty when not connected to power;
- use of the water heater in a manner contrary to this manual or other instructions provided by Dux;
- alterations or repair of the water heater other than by an accredited and licensed service agent or technician;
- accidental damage or abuse;
- where the water heater has been tilted more than 30 degrees from vertical;
- if the water pH is less than 6.5 or greater than 9.5;
- where penetrations damage the heat exchanger coil on the tank, or the inner tank cylinder, warranty will be void.

If the water heater is installed in a position that does not comply with the installation instructions or statutory requirements, then this warranty does not cover major dismantling or removal of

cupboards, doors, walls or special equipment and/or excessive labour, at the determination of Dux, to make the water heater accessible for repair or replacement.

Where the Dux water heater is located outside the metropolitan area of a capital city and is more than 100km from a Dux office or Dux agent, the Owner will be responsible under the warranty for paying the costs of transporting the water heater and or any component in the water heater to and from an approved Dux agent or Dux office (including any insurance associated with that transport), or paying the travelling time of an approved Dux agent to and from the owners premises.

Commencement of Warranty:

The warranty period commences from the date of installation of the water heater. Where proof of the date of installation is not available, the warranty period commences on the date of manufacture of the water heater. This is shown on the compliance plate on the outside of the water heater.

The replacement of the water heater, or a component of it, under this warranty does not change the warranty commencement date. The repaired or replaced part/tank does not carry any additional warranty period. The original commencement date continues to apply.

WARRANTY

Exclusion and Limitation of Liability:

In addition to any other provisions set out in this document and to the maximum extent permitted by any applicable law or regulation, Dux will not be liable for any claim:

1. for consequential loss to any property arising directly or indirectly out of or connected to the supply or installation of the water heater. This includes but is not limited to furnishings, carpets, foundations, housing effects and buildings.
2. for any direct or indirect economic or financial loss of any nature.
3. arising out of or connected to a water heater that has been uninstalled, resold or moved from its original installation location.
4. arising out of or connected to any misuse, or other use, installation or maintenance that is not in accordance with the procedures and requirements set out in this document.

To the extent permitted by law the liability of Dux shall be limited to the cost of the repair or replacement of the water heater.

The Australian Consumer Law ("ACL"):

Our goods come with guarantees that cannot be excluded under the Australian Consumer Law. You are entitled to a replacement or refund for a major failure and compensation for any other reasonably foreseeable loss or damage. You are also entitled to have the goods repaired or replaced if the goods fail to be of acceptable quality and the failure does not amount to a major failure.

If Dux fails to meet a guarantee under the ACL, your remedy for such failure may be limited to any one or more of the following:

- replacement of the water heater;
- repair of the water heater;
- refunding the cost of the water heater;
- payment of the reasonable costs of having the water heater repaired;
- payment in respect of the reduced value of the water heater.

WARRANTY

The Consumer Guarantees Act 1993 (New Zealand):

Our goods come with guarantees that cannot be excluded under the Consumer Guarantees Act 1993 (New Zealand). If the goods fail to comply with the applicable guarantees set out under the Consumer Guarantees Act 1993 (New Zealand) being the guarantee as to acceptable quality, the guarantee as to correspondence with description or the guarantee as to repair and parts, or if the goods fail to comply with any express guarantee given by Dux, then you are entitled to a replacement or refund and for compensation for any other reasonably foreseeable loss or damage.

How to Make a Warranty Claim:

Warranty claims can be placed by completing the following steps:

Please consult Customer Service:

- 1300 412 612 (Australia);
- 0800 081 909 or contact your local Reece branch (New Zealand).
- Provide the serial number and model number of the water heater. This can be found on the compliance plate on the outside of the water heater.
- Provide your full name, address and contact number.
- Provide proof of date of installation for warranty to commence from that date, rather than from the date of manufacture. See Commencement of Warranty on page 50.

Please note, if the defect or fault is not covered by the warranty or guarantee, you will be responsible for the costs incurred by the service agent or technician.

Dux service calls can only be scheduled during business hours (AEST) Monday to Friday and are not available on weekends & public holidays.

WARRANTY

Contact Details:

Dux Manufacturing Limited
Lackey Road, Moss Vale, NSW, 2577
Australia

1300 412 612 (Australia)

0800 081 909 or contact your local
Reece branch (New Zealand)

Email: duxaftersales@dux.com.au

