

Billi®

Commercial Installation Guide

Installation Guide Billi Quadra
& Billi Quadra Plus

(904010, 904020, 904025, 904040,
904060, 904065, 904100, 904105,
904107, 904180, 904187)

Dispenser Options:
XT Motion, Multifunction Mixer
Tap, & Plus Mixer Tap



CONTENTS

Warnings and Important Information	3
Warnings and Important Information	4
Unpacking your Billi Quadra	5
Included Components	5
Installation Requirements	5
Installing the dispenser. XL, XT, XR, XT Motion.	7
Additional installation - XR - Proud mount remote panel.	9
Installing Multifunction Mixer Tapware	10
Installing underbench module	11
Installing underbench module.	12
Installing Quadra Plus mixer tap.	13
Components for Quadra Plus mixer tap.	13
Commissioning	15
Installation and Commission Checklist	17

Warnings and Important Information

- For continued safety of this appliance, it must be installed, operated and maintained in accordance with the manufacturer's instructions. Your appliance should be installed by the manufacturer, a service agent, or any other suitably qualified tradesperson.
- For correct operation of this appliance, it is essential to observe the instructions as outlined in this booklet.
- Do not use this appliance with water that is microbiologically unsafe or with water of unknown quality without adequate disinfection before or after the system. Systems certified for cyst reduction may be used on disinfected water that may contain filterable cysts.
- Filter replacement must be performed at intervals of not more than 12 months.
- Use this appliance only as directed in these instructions and only for its designed purpose.
- This appliance is not intended for use by persons (including children) with reduced physical, sensory or mental capabilities, or persons with lack of experience and knowledge, unless they are supervised or have been given instruction concerning use by a person responsible for their safety.
- This appliance is not to be installed in an area where a water jet could be used. Children should be supervised to ensure that they do not play with the appliance.
- **DANGER:** The operation of the flange mounted thermal cut-out indicates a possibly dangerous situation. Do not reset the thermal cut-out until the appliance has been serviced by a suitably qualified person.
- **WARNING:** Do not connect any restrictor, pressure relief device or non-return valve to the vent pipe of this appliance.
- **WARNING:** When positioning the appliance ensure the power supply cord is not trapped or damaged.
- **WARNING:** Do not install the appliance using a power board, double power adaptor or any other similar device. The appliance is to be plugged directly into a suitably protected and rated power point.
- **WARNING:** If the power supply cord is damaged, it must be replaced by the manufacturer, its service agent, or similarly qualified persons. The appliance is not to be used until the power supply cord is repaired.
- **WARNING:** Avoid spillages of any kind on all electrical connectors.
- **WARNING:** Potential injury can result from misuse.
- **WARNING:** Internal surfaces adjacent to and directly in contact with the heating element are subject to residual heat after use.
- Only Billi hose and tube kits as supplied with the appliance are to be used. Old or other manufacturer's hose and tube kits should not be used.
- **WARNING:** This appliance may deliver water at high temperature. Refer to the plumbing code of Australia (PCA), local requirements and installation instructions to determine if additional temperature control is required.
- **WARNING:** Installation shall conform to the plumbing code of Australia (PCA) or relevant local requirements.
- If the appliance is installed in a location where the ambient air temperature could fall below 4°C, do not turn off power to the appliance to prevent malfunction. This safeguard does not offer protection to connecting pipework and fittings external to the appliance.
- The appliance is designed to operate in an ambient air temperature range of 5°C to 30°C.
- Turn off power to the appliance by unplugging the power cord from the connected power point. Only do so after the inlet water supply has been turned off.
- The appliance is intended to be used in commercial and similar applications such as:
 - Staff kitchen areas in shops, offices, and other working environments.
 - By clients in hotels, motels, and other residential type environments.
 - Bed and breakfast type environments.
 - Catering and similar non-retail applications.
- Please note maximum inlet water pressure is 1000kPa.

Warnings and Important Information

R290 REFRIGERANT WARNINGS



Warning: RISK OF FIRE / FLAMMABLE MATERIALS

NOTE: This model uses 0.050kg of R290 flammable refrigerant in a sealed system. The following must be observed for your safety:

- This appliance contains a small quantity of R290 refrigerant which is environmentally friendly but flammable. It does not damage the ozone layer, nor does it contribute to the greenhouse effect.
- During transportation and installation, ensure that the tubing of the refrigerant circuit is not trapped or damaged.
- Leaking refrigerant can ignite or cause irritation and permanent damage to the eyes or respiratory.
- In the event any damage or leak does occur,
 - immediately isolate and disconnect the appliance from mains power
 - avoid exposure to open flame or any device which could cause ignition via spark.
- Vacate and thoroughly ventilate the room in which the appliance is located for several minutes.
- Contact and notify Customer Support for necessary actions and advice.
- The room for installing the appliance must be at least 1 cubic metre per 0.08 kilograms of refrigerant. The refrigerant quantity contained in this appliance listed above in kilograms, it is also noted on the Rating Plate of the appliance.
- Keep Ventilation openings in the appliance enclosure or in the built-in structure clear of obstruction
- **It is hazardous for anyone other than an authorised service person to carry out servicing or repairs to this appliance. In some jurisdictions the authorised person must hold a Gas Work authorisation for hydrocarbon refrigerant before carrying out works that involve the removal of covers.**

WARNING

The environment and personal safety must be considered when disposing of this appliance. Please ensure the appliance is taken to the recycle centre for safe recycling. DO NOT dispose of the appliance in land fill as the refrigerant gas contained in these appliances are flammable.

DISPOSAL

Superseded equipment holds residual recovery value and forms part of Billi's Global Greentag certified cradle to cradle philosophy. An environmentally friendly method of disposal will ensure that valuable raw materials can be recovered and used again.

The refrigerant used in your appliance requires special disposal procedures. Up to date information for disposing of your old appliance and packaging from the new one can be obtained from your local council office.

Unpacking your Billi Quadra

Before commencing installation, carefully check for any damage to outer carton, inner liner, appliance metalwork, pipework fittings and electrical power cord. If damage is found, please photograph and record details for use if a claim is to be made.

Included Components

Before commencing installation, ensure you have identified the following.

1. Underbench module
 - a. Filter in place behind front panel
2. Dispenser kit (XL, XT, XR, VP, MMT, XT Motion)
3. Installation kit
 - a. 600mm flexible braided hose
 - b. 3/16 Drain tube with 3/8 adapter
 - c. Tube spring clamps x 3
 - d. Allen key
 - e. Drain clamp
 - f. Drain nipple connection
 - g. Drain adapter
 - h. Drain connection instruction kit
4. Literature kit
 - a. Installation guide
 - b. User guide
 - c. Warranty card
 - d. Caution Label
5. Mixer tap kit (Plus Units Only)

Installation Requirements

Determine Unit Location

Plan the installation carefully, taking into consideration dispenser tube lengths, position of power and water outlets, and access for servicing. The Billi Quadra is to be installed indoors only and must be installed on a level surface with the display panel facing the front of the cupboard. Refer to **Diagram 1** for a typical installation scenario.

The Quadra is designed for internal installation only.

Model	Height	Width	Depth
Quadra Compact	340mm	315mm	365mm
Quadra 420, 440, 460, 4100, 4180 models/ Quadra Plus	340mm	315mm	465mm

Installation Requirements cont.

Water Supply

The Quadra underbench module must only be connected to a cold-water supply. A ½" BSP stop tap (not supplied) is to be installed in an easily accessible position within 600mm from the Quadra water supply inlet. The Quadra incorporates a certified pressure limiting valve with internal dual check valve for backflow prevention. Do not fit an additional pressure limiting valve.

For installations with MMT, a hot water point is also required.

Dynamic water supply pressure:

Min. 250kPa, max. 1000kPa

Supply temp: min. 5°C, max. 30°C.

Do not install with water that is microbiologically unsafe or with water of unknown quality without adequate disinfection before or after the system. Systems certified for cyst reduction may be used on disinfected water that may contain filterable cysts.

Power Requirements

A single 3-pin GPO is required. A dedicated circuit should be provided and must be fitted with an earth leakage protection device (RCD). An externally fitted RCD device is acceptable.

10A systems: Quadra Compact 420, 440, 460, Plus 5 and Plus 9 require a 10-amp rating.

15A systems: Quadra 4100 and Plus 15 require a 15-amp rating

20A systems: Quadra 4180 requires a 20-amp rating.

All Quadra models are supplied with a 1 metre power cord and plug.

Drainage

Quadra models require a drainage point such as a dishwasher nipple. Use the nipple adaptor fitting supplied or the clamp-on drain adaptor (both supplied with system). Clamp-on drain adaptor must be installed above the water seal on the sink side of the water trap. A dual check valve is integrated within the drain connection.

Ventilation

Quadra range doesn't require any ventilation as it is water cooled.

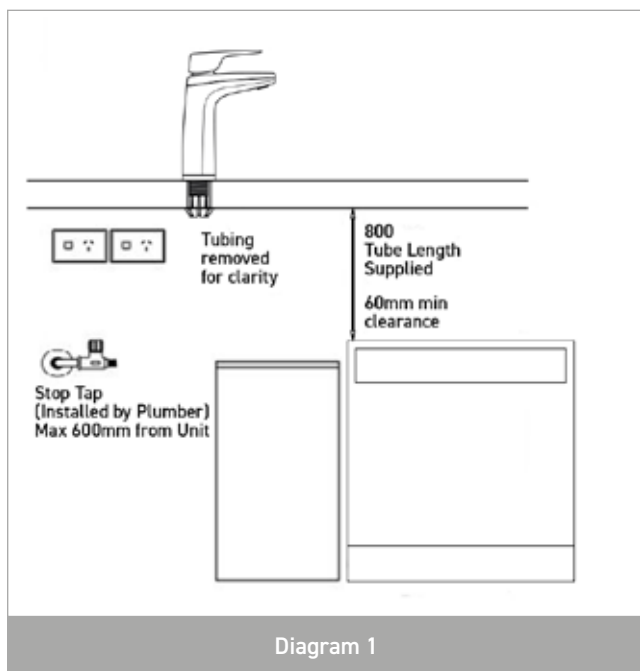

Installing the dispenser. XL, XT, XR, XT Motion.

IMPORTANT: This Billi appliance is to be installed by a licensed tradesperson in accordance with AS/NZS 3500.1 and AS/NZ 3500.2 and in compliance with applicable state regulatory requirements. For correct operation of this appliance, it is essential to observe the manufacturer's instructions.

IMPORTANT: The Billi XL & XT Motion dispenser is supplied with base assembly preassembled into dispenser upper and this must be first removed prior to starting installation. Using Allen key supplied in installation kit, remove chrome plated M4 screw from rear of housing. Twist base casting around 60° and then slide assembly out of upper housing. Carefully pull tubing and electrical cable and plug through base assembly.

Components in Dispenser Kit

IMPORTANT: This Billi appliance is to be installed by a licensed tradesperson in accordance with AS/NZS 3500.1 and AS/NZ 3500.2 and in compliance with applicable state regulatory requirements. For the correct operation of this appliance, it is essential to observe the manufacturer's instructions.

Before commencing installation, identify the following components:

1. Dispenser
2. Large D-Washer

1. Determine Dispenser Location

The XL dispenser can be installed on a surface 1mm –48mm thick and requires a hole size of $\varnothing 35$ mm. All tube and signal cable lengths are 800mm and connect to top rear of underbench module.

Ensure to leave sufficient room (Min. 20mm) for the safety lock button on rear of dispenser head. Minimum flat surface area of 55mm diameter required for proper seal of tap base, refer to diagram 2. Refer to diagram 3 for dimensions of the dispenser.

2. Cut $\varnothing 35$ mm Hole in Sinktop or Benchtop

a. Stainless Steel Sinktop

A suitable $\varnothing 35$ mm hole punch (Part no: 857901) is available as an accessory from Billi Australia Pty Ltd. If possible, cut hole with die mounted below the sinktop surface so burrs are pulled downwards. Alternatively, remove burrs and radius edge of hole with a fine file.

b. Timber/Laminate Benchtop

Take care to avoid large chips breaking as the drill breaks through underside surface. We recommend drilling a small pilot hole through the benchtop, partially drilling $\varnothing 35$ mm hole from underneath, and then completing drilling hole from above.

*For all stone benchtops we recommend you use a certified stone mason to pre-drill the hole.

3. Prepare Dispenser Base Assembly for Installation

- a) Remove retaining screw on rear back of dispenser using supplied hex key.
- b) Turn dispenser base 30° then pull down to separate completely from main body, sliding over tubes and power cord. Refer to Diagram 4 and 5.
- c) Place the main body aside.
- d) Activate dispenser swivel feature if desired by pushing out locking piece as shown in Diagram 6.
- e) Remove base casting from barbed mounting shaft by unscrewing locking nut.
- f) Position critical locking sleeve at base of barbed mounting shaft, ensuring it contacts the moulded stop. Refer to Diagram 7.
- g) Push the barbed mounting shaft through underside of mount hole with barb facing down. A large D-washer is recommended to be used if there is room.
 - i. Insert D-washer over barbed mounting shaft prior to insertion through bench if it is used. Refer to Diagram 7.
- h) Re-assemble base casting and locking nut with barbed mounting shaft. Take care to align flat face on barbed mounting shaft with flat face in hole of base casting.
- i) Finger tightens the locking nut.
- j) Check critical locking sleeve is still positioned at base of barbed mounting shaft.
- k) Ensure barbs are centered in mount hole and alignment of base is correct. Moderately tighten the locking nut using multigrips or spanner. Avoid overtightening the locking nut to avoid damaging the barbed mounting shaft. Refer to Diagram 8.

4. Install Dispenser Main Body

- a) Feed all tubing and power cord through holes in the dispenser base. The feed power cord is first followed by tubes. Refer to Diagram 9.
- b) Gently pull all tubes and power cords, ensuring tubes aren't kinked or twisted. Do not attempt to force tubing or power cord through with a pointed object as this may cause damage.
- c) Re-assemble dispenser base and main body by turning main body 30° in relation to dispenser base and pushing down. Gently pull tubing and power cord downwards at the same time from underneath to prevent kinking and bunching.
- d) Turn dispenser main body straight once fully inserted and re-install retaining screw on rear back of dispenser.
- e) If swivel feature has been activated check dispenser now smoothly swivels 45° in each direction.

Installing the dispenser. XL, XT, XR contd.

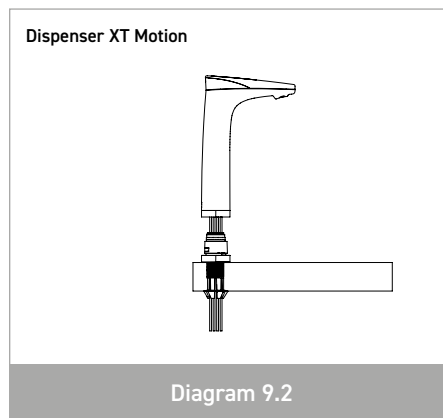
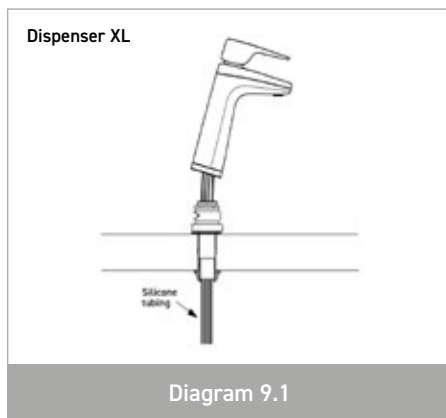
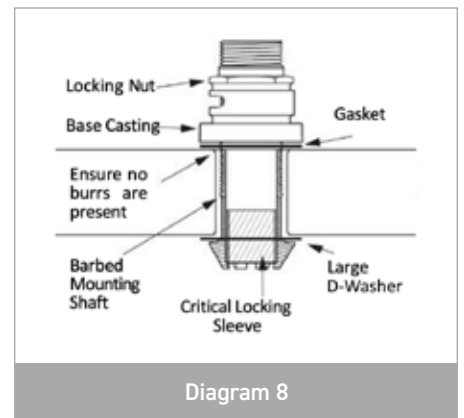
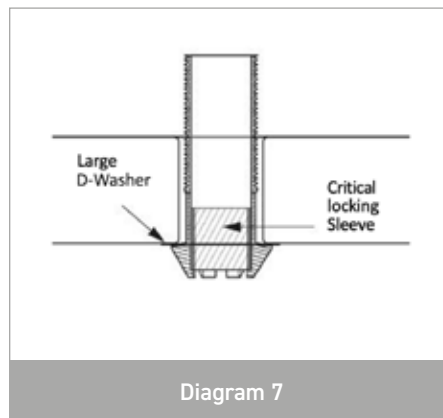
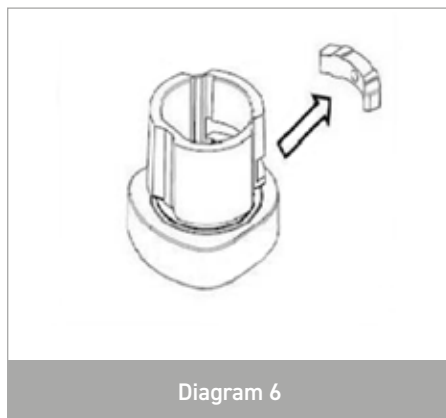
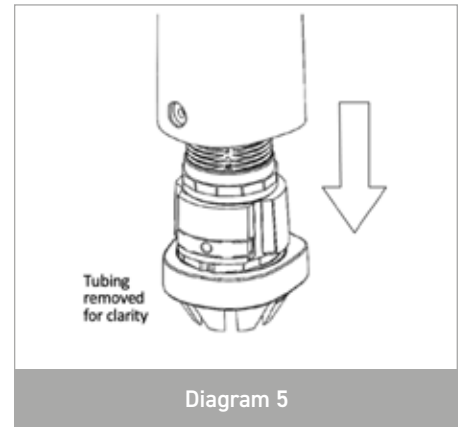
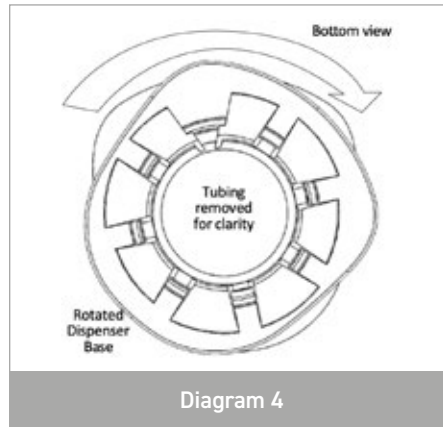
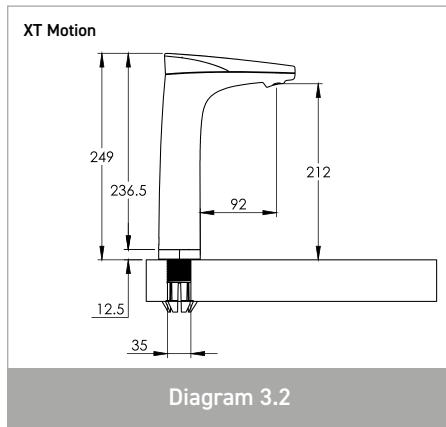
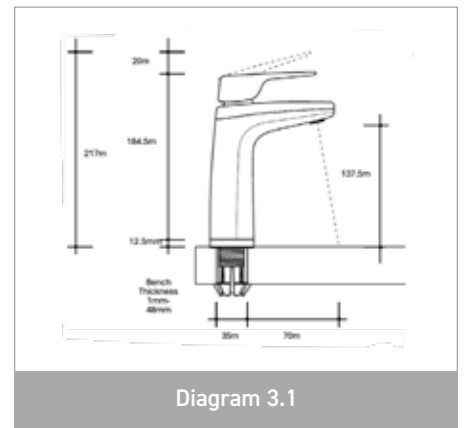
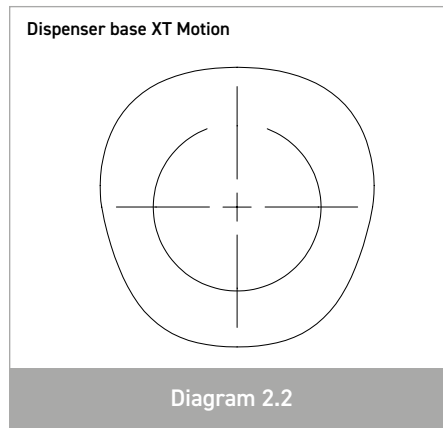
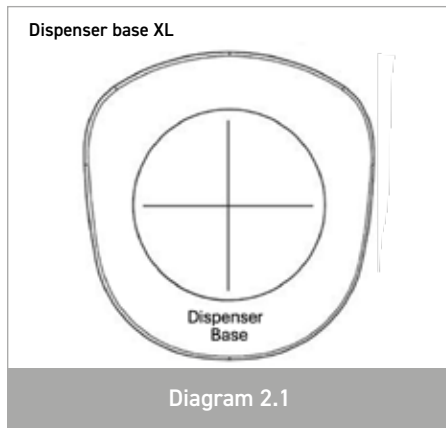

Additional installation – XR - Proud mount remote panel.

Determine Remote Panel Location

Cut out cable access hole in the desired location. Hole size must be Width 25mm x Height 45mm – see diagram 13.

Drill a pilot hole using bracket as a template. The template could also be used as a guide to cut into the plaster.

Install Mount Bracket

Fasten the mount bracket on to the wall using Philips head screwdriver (ensure the spring clips are facing up) – see diagram 14.

Install Cabling

Feed the cable through pre cut hole. Screw and fasten the cable strain bracket to the back of remote tap module. Secure the tap module by sliding it onto the previously installed bracket – see diagram 15. Plug loom into remote module.

Completing Installation

Ensure panel is secured. Clean up any excess plaster. Installation is finished – see diagram 16.

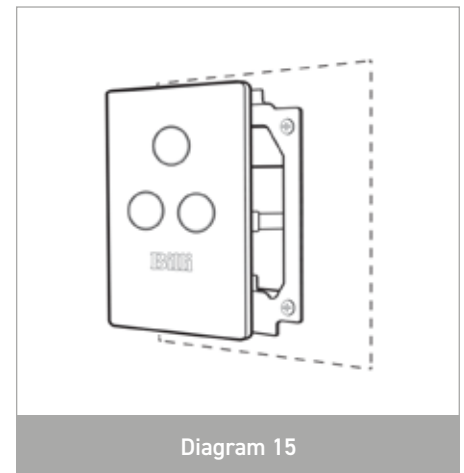
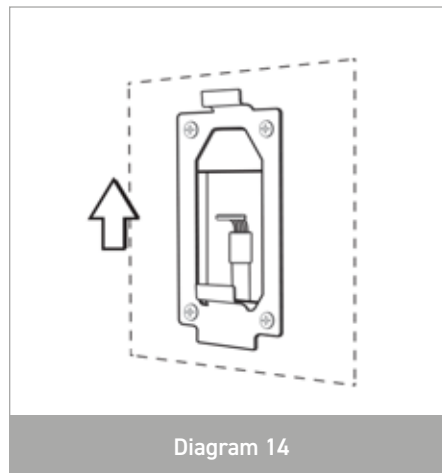
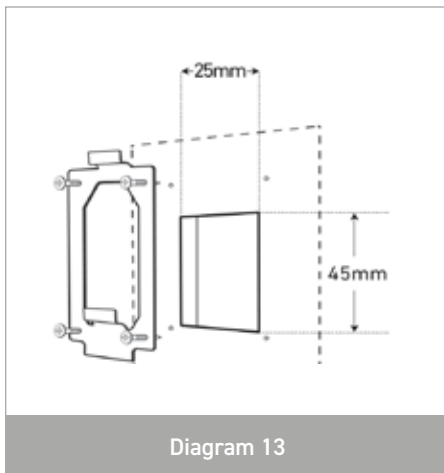

Installing vandal proof tap

Refer to instructions included with Vandal Proof Kit.

Installing Multifunction Mixer Tapware

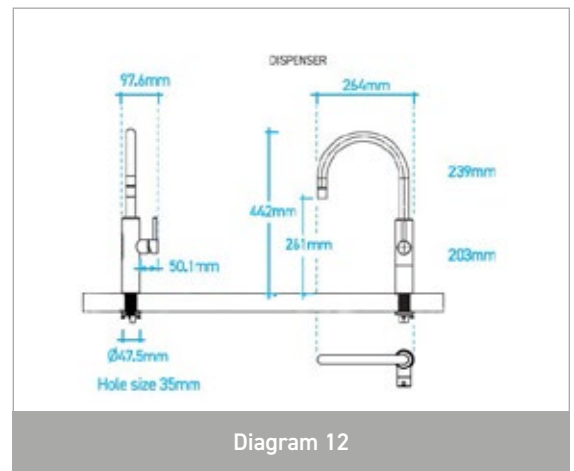
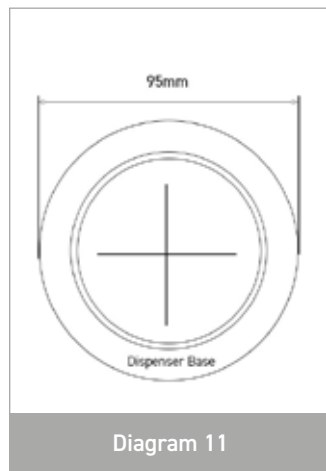
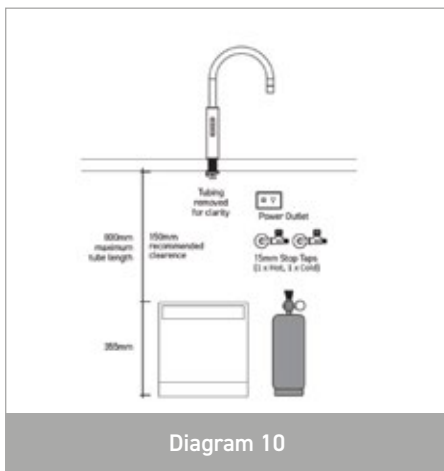

1. Determine Dispenser Location

The MMT dispenser can be installed on a surface 1mm –48mm thick and requires a hole size of $\varnothing 35\text{mm}$. All tube and signal cable lengths are 800mm and connect to the top rear of underbench module.

Refer to Diagram 11 for a base template that may be cut out to assist in positioning, and Diagram 12 for dimensions of dispenser. Ensure to leave sufficient room for the safety lock button on rear of dispenser head.

2. Cut $\varnothing 35\text{mm}$ Hole in Sink top or Benchtop

a. Stainless Steel Sink top

A suitable $\varnothing 35\text{mm}$ hole punch (Part no: 857901) is available as an accessory from Billi Australia Pty Ltd. If possible, cut the hole with the die mounted below the sink top surface so burrs are pulled downwards. Alternatively, remove burrs and radius edge of hole with a fine file.

b. Timber/Laminate Benchtop

Take care to avoid a large chip breaking as the drill breaks through the underside surface. We recommend drilling a small pilot hole through the benchtop, partially drilling $\varnothing 35\text{mm}$ hole from underneath, and then completing the drilling hole from above.

*For all stone benchtops we recommend you use a certified stone mason to pre-drill the hole.

3. Prepare MMT Mixer Tap Base for Installation

- Remove the ring bracket located underneath the MMT tap assembly by turning it counterclockwise. Refer to Diagram 13.
- Set the ring bracket aside in a safe location.
- Ensure the tubing is straightened and free from kinks before proceeding.

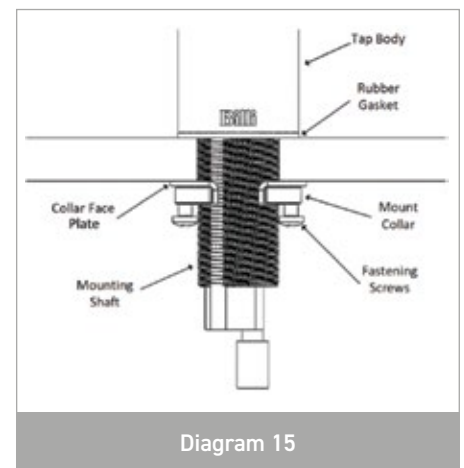
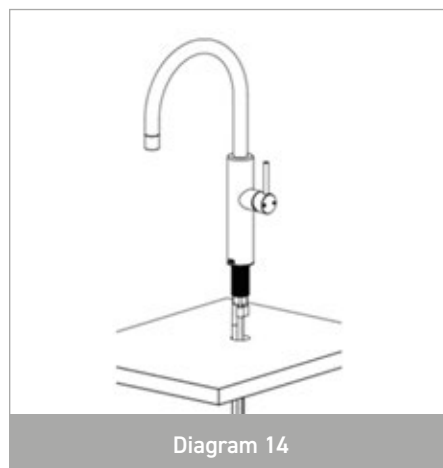
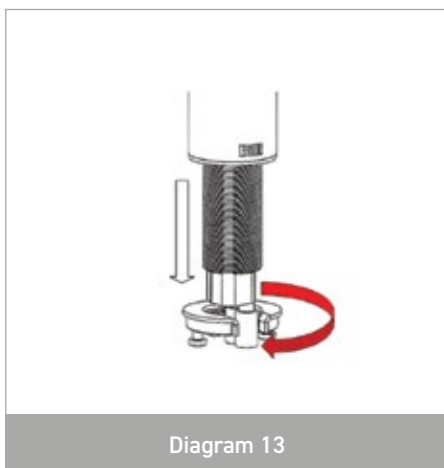

Installing underbench module

1. Flush Water Supply

Flush water supply pipework before installing the underbench unit by connecting 600mm flexible braided hose to the supply tap and running water into a bucket. Blockages/unit malfunction caused by debris are not covered under warranty.

2. Install Underbench Unit

Take care to observe minimum clearances. Ensure there is adequate access to service the unit, taking into account the tube lengths and space available Refer Diagram 1.

3. Connect Dispenser Tubing and Electrical Plug

Connect all tubing and electrical plug as shown. For Quadra Compact – refer to Diagram 17a and 18a. For Quadra 420 to 4180 –refer 17b to Diagram 18b. For Quadra Plus 5, Plus 9 and Plus 15, refer to Diagram 17a, 17b and 22a and 22b and additional instructions on the following page.

Ensure correct orientation of dispenser power plug before insertion. Trim tubes to correct lengths using a sharp knife or plastic tube cutter. Do not leave excess tubing which will sag, trapping water. Fit spring clamps supplied to retain silicone rubber tubing to barbed fittings.

IMPORTANT: Boiling outlet (red), vent tube (grey) must not be kinked and must be installed with a continual fall and no sag.

4. Connect to Drainage Point

a) Option 1: to dishwasher nipple on waste trap

- i. Drill hole in dishwasher nipple (min. 10mm)
- ii. Push larger end of supplied drain boot fully over dishwasher nipple.
- iii. Push 3/8" tube on supplied drain tube assembly at least 15mm into drain boot. Ensure arrow on drain label is pointing into the drain boot.
- iv. Connect 3/16" tube on supplied drain tube assembly to condenser outlet as per Diagram 18. Nut to be finger tightened only.

b) Option 2: directly to waste trap

- i. Drill a 1/2" hole in the side of the waste trap. Hole is to be least 10mm above water level in the trap and on the sink side only.
- ii. Clip drain adaptor to drain clamp, ensuring tabs on drain adaptor engage with slots in drain clamp.
- iii. Fit drain clamp and adaptor assembly over hole in waste trap. Ensure drain adaptor is oriented with push-fit connection angled up and spigot pushed into drilled hole.
- iv. Tighten drain clamp.
- v. Push 3/8" tube on supplied drain tube assembly fully into drain adaptor. Ensure arrow on drain label is pointing into drain adaptor.
- vi. Connect 3/16" tube on supplied drain tube assembly to condenser outlet as per Diagram 12. Nut to be finger tightened only

Installing underbench module.

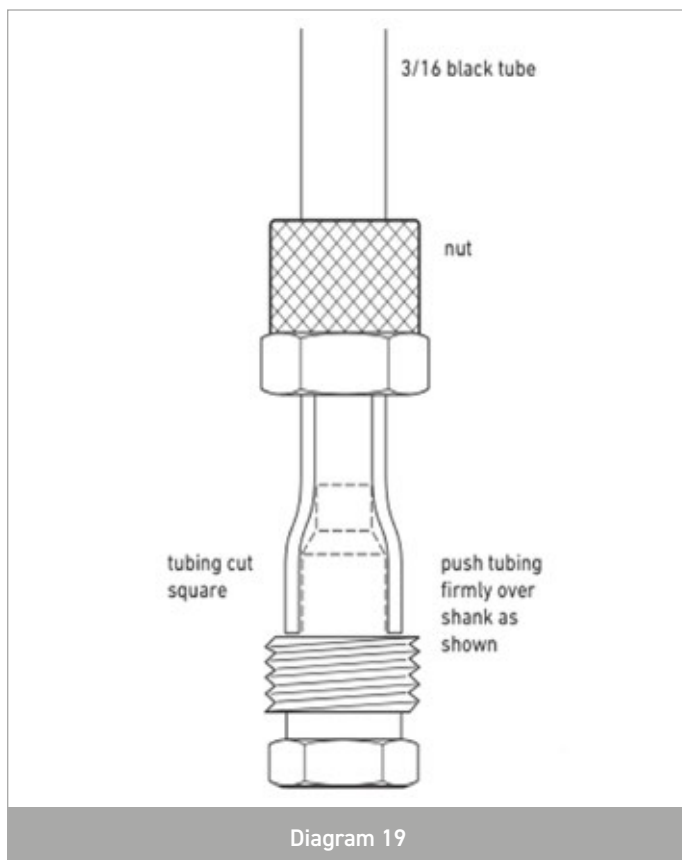
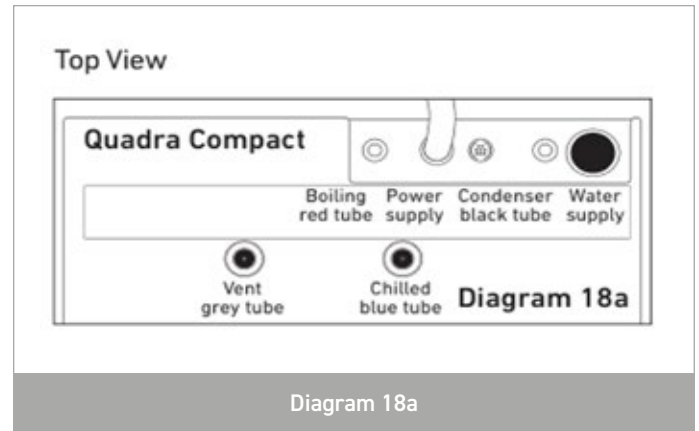
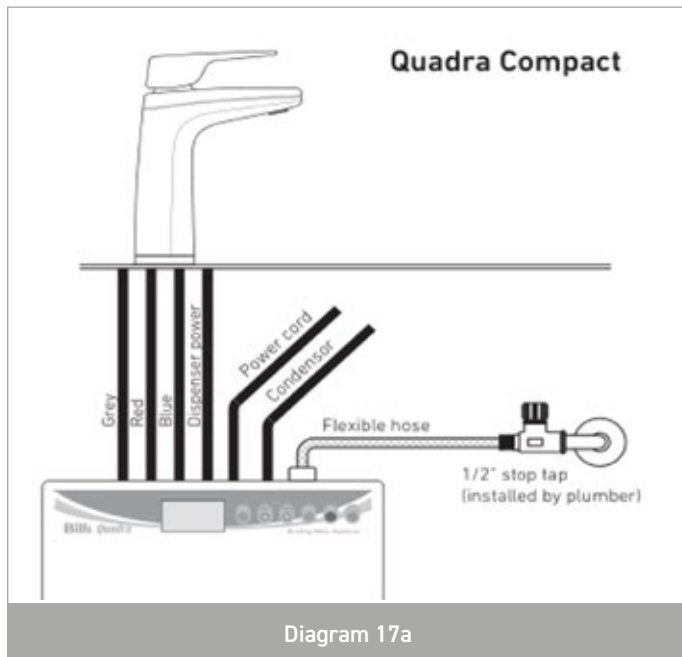

Installing Quadra Plus mixer tap.

Additional Components for Billi Quadra Plus 5, Plus 9 and Plus 15 Models

Before commencing installation, identify the following components:

Components for Quadra Plus mixer tap.

Before commencing installation, ensure you have identified the following.

1. O-ring (large)
2. Tap base ring
3. Mount clamp (brass)
4. Mount clamp plate gasket
5. Mount thread
6. Extended fixing nut
7. Barb adaptor fitting (short)
8. Barb adaptor fitting (extended)
9. Spring hose clamps x 2
10. ½" joining nipple
11. 1 metre Silicone tubing
12. Braided flexible hoses x 3
 - i. Marked 'TAP-H'
 - ii. Marked 'TAP-IN'
 - iii. Marked 'TAP-OUT'
13. Mixer Tap

Mixer Tap Mounting Procedure

1. Mixer Tap Mounting Procedure Drill or punch mount hole and deburr.
 - Hole size: 35mm.
 - Sink or Benchtop thickness: 1 – 45mm.
2. Insert tap base ring over mounting thread. Ensure it is flush against the tap body with inset O-ring facing down.
3. Screw barb adaptor fitting (extended) marked 'TAP-H' into marked 'H' threaded hole in base of mixer tap.
4. Insert mixer tap through the mount hole and place tap in correct position with Billi logo facing front.
5. Insert the large gasket, followed by mount clamp plate gasket. Finally insert the brass mount clamp with 3 locking screws. See diagram 20.

NOTE: Ensure that the grooves from the mount clamp plate gasket are inserted into the channel of the brass mount clamp.

6. Hand tighten the fastening assembly until it is quite firm. Using a Philips head screw driver tighten locking screws until the dispenser is firmly secured. See diagram 20.
7. Insert braided flexible hose marked 'TAP- OUT' into marked 'OUT' threaded hole into base of mixer tap. Screw in clockwise until tight.
8. Insert braided flexible hose marked 'TAP-IN' into marked 'IN' threaded hole into base of mixer tap. Screw in clockwise until tight.
9. Push Silicone tubing onto barb and fit spring hose clamp. Position hose clamp lugs as shown in Diagram 21.

Installing Quadra Plus mixer tap contd.

Connecting Mixer Tap to Quadra Plus

Fit tubing connections as shown in Diagram 22a 1.& 22b.

1. Water supply inlet tube marked 'TAP-IN' incorporates an inline strainer. Connect to ½" BSP stop tap.
2. Fit short barb adaptor to port at the rear of Quadra unit marked 'Hot Outlet'. Trim Silicone tubing to correct length using sharp knife. Excess tubing will cause sagging and possible kinking. Push tube onto barb adaptor and fit spring hose clamp. Support may be needed for PVC tube if there is a horizontal run.
3. Fit braided coupling marked 'UNIT HOT-IN' to matching port. Join to braided coupling marked 'TAP-OUT' using ½" joining nipple.

Operating the Mixer Tap

Operation of the mixer tap is as with any single lever tap. Lift lever to start water flow. Swing to the left for hot water and to the right for cold water.

Hot water will not be available until Quadra boiling water tank has filled and heated Bubbling in the hot water flow indicates insufficient boiling water is available. Wait a few minutes for tank to fill and heat.

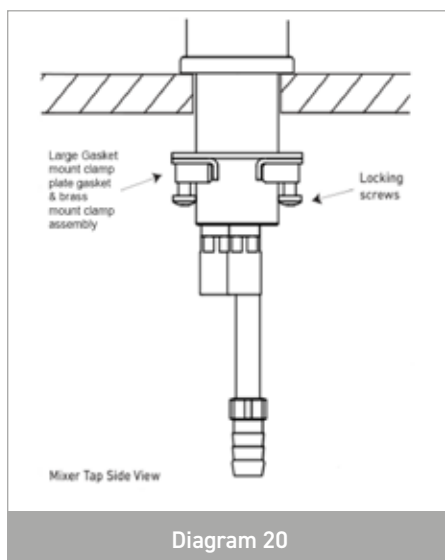

Diagram 20

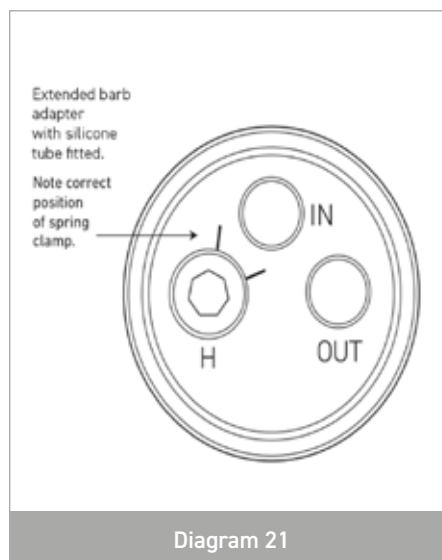

Diagram 21

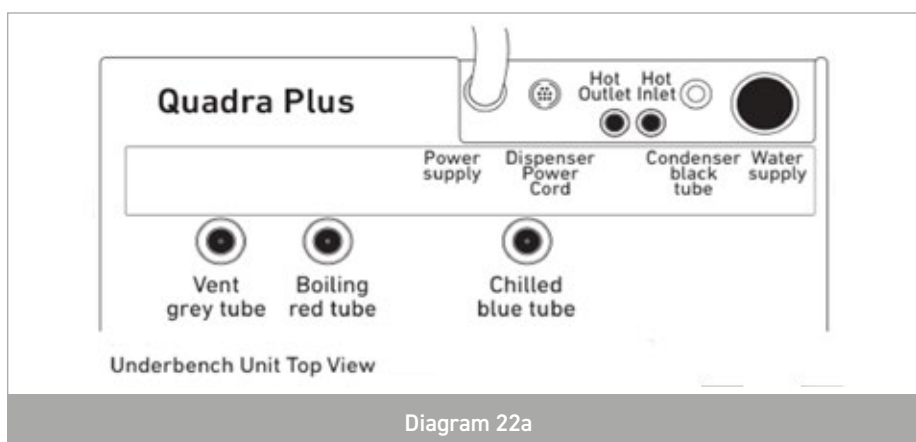

Diagram 22a

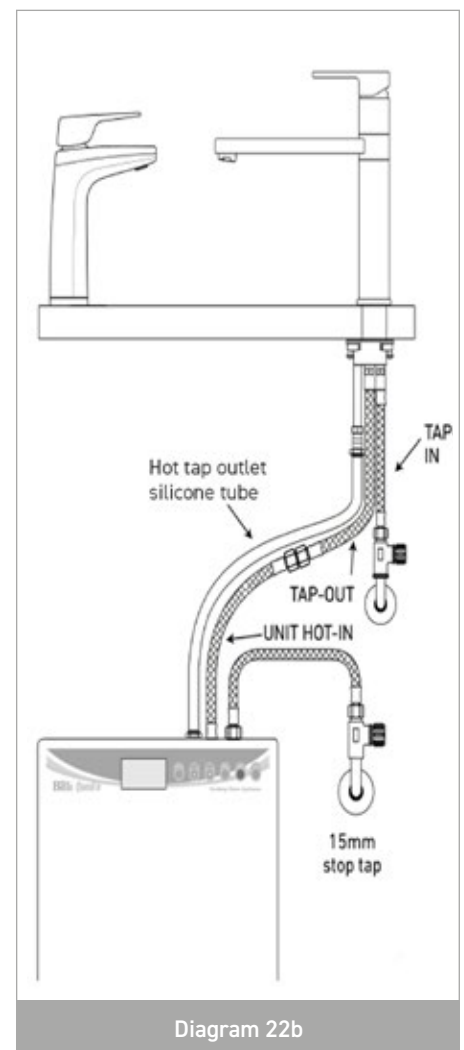





Diagram 22b

Commissioning

Dispenser settings:

Quadra unit factory default setting is XL dispenser. If you are using the XL dispenser, skip to the **“Turn on Water Supply”** section:

If you are using XT, XT Motion, XR, VP or MMT, follow these steps:

1. **Step 1 is for MMT only, for other taps, proceed to step 2. Temporarily swap the red and black tap tubes so that the red boiling tube is connected to the vent outlet of the unit and the black vent tube is connected to the boiling outlet of the unit. This allows for increased venting during calibration.**
2. With water supply OFF & tap loom disconnected, turn switch on at power outlet.
3. Once powered on, unit will immediately display one of 3 faults: HOTTAP SENSOR FAIL, COLDTAP SENSOR FAIL or XL TAP DISCONNECTED.
4. From the fault screen press SELECT twice (or once for units showing “XL TAP DISCONNECTED”), the screen will now change to “User Menu”.
5. Press SELECT again, screen will change to the “Set Time/Date” screen.
6. Press & hold HELP until the A or P of AM/PM changes momentarily to “?” and then release HELP.
7. Press BACK, then press HELP. The screen should now change to the “Service Mode” menu.
8. Using   scroll to “Settings2” menu and press SELECT.
9. Scroll to “TapType” and press SELECT.
10. Using  , cycle to the desired option and press SELECT.
 - a) XT/XR dispenser select “XT” option.
 - b) VP dispenser select “QL” option.
 - c) MMT/XT Motion dispenser select “AL” option.
11. Press BACK 3 times to return to default screen.
12. Turn unit off at power outlet and connect tap loom to unit.
13. Turn water supply ON, and then turn Power ON at power outlet.
14. Unit will now enter startup sequence.
15. Test tap functions to ensure tap type is set correctly.
16. **This step is for MMT only; once calibration is complete, swap the red boiling tube and black vent tube back so that they are re-connected to their default outlets. Skip to “Cold water section”.**

Turn on Water Supply

Turn on the water supply tap and check there are no leaks. Remove front panel of unit and remove foam packing from under the filter canister. Ensure filter canister is securely locked back into place. Replace front panel.

Turn On Electricity

Turn on power switch. Check normal time display is showing. Status line should display ‘INITIAL FILL’. Boiling and chilled water tanks are now filling. Dispenser icons flash orange slowly

Check normal time display is showing. Status line should display ‘INITIAL FILL’. Boiling and chilled water tanks are now filling. Dispenser icons flash orange slowly.

Cold Water

During the initial fill, cold water valve automatically opens to fill the cold tank. After approximately 1 minute, cold water will begin to flow from the dispenser outlet. Water will continue to run for a further minute to flush and condition the filters.

Hot Water (Auto Boiling Calibration)

Auto Boiling Point Calibration: The hot tank will first fill to the height of the low level sensor. The water is then heated until it reaches boiling point. The unit will continue to boil for up to 30 seconds while the temperature sensor calibrates.

WARNING: Steam and small amount of hot water may be discharged from the taps and vent during this period. While calibration is underway the hot water indicator will flash yellow. The hot water set point is calibrated 1.5°C below the boiling point. Once calibrated, the unit will resume normal operation and the calibration data will be saved. The unit will not re-calibrate under normal circumstances.

Setting the Programs

The Quadra operational settings have been factory set for a typical installation. Clock is set to Australian Eastern Standard Time (AEST). Refer to Quadra User Guide for setting instructions. In some installations, boiling water delivery settings may need to be changed as outlined below.

Tube length setting

The Quadra's boiling water flow rate slows briefly as water first enters the cup to prevent splashing. Correct timing of the moment of reduced flow is dependent on the length of the tube between the Quadra module and the dispenser. The standard timing is set for a tube length of 500mm but this setting can be simply altered to suit the installation. After installation, measure the length of the red tube from the underside of the dispenser to the boiling water outlet fitting. If the measured length is less than 450mm or greater than 550mm, the correct value should be set in as follows:

1. Press n SELECT. Display changes to menu selection mode.
2. Press ▼ 4 times. Shaded cursor shows 'INITIAL SETUP'.
3. Press n SELECT. Display shows:
4. Press n SELECT. '0500 mm' flashes.
5. Press ▲ or ▼ buttons to enter the correct tube length.
6. Press n SELECT.
7. Press n BACK twice to return to normal display.

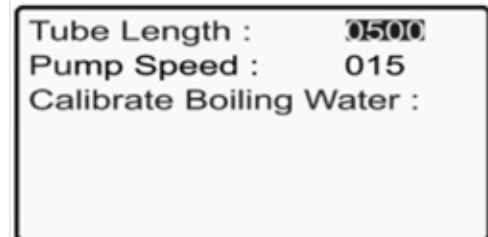

Boiling water flow rate

The boiling water flow rate can be adjusted to suit the installation or user preference. Extended tube lengths will require the pump speed to be increased.

1. To adjust, use the selection procedure as described above in Steps 1, 2 and 3.
2. Press n SELECT. Shaded cursor shows 'Pump Speed 015'.
3. Press n SELECT. '015' flashes.
4. Press ▲ or ▼ buttons to increase or decrease. Range is between 1 and 20.
5. Press n SELECT.
6. Press n BACK twice to return to normal display.

Calibrating boiling water temperature (Manually)

Manual calibration can be performed at any time using the instructions below:

The procedure is as follows;

1. Use the selection procedure as described above, in Steps 1, 2 and 3.
2. Press n SELECT twice to select 'Calibrate Boiling Water'.
3. Press n SELECT twice to begin cycle.
4. The unit will fill and heat (if not yet up to operating temperature before cycle begins).

CAUTION: Steam will discharge from the vent outlet located between the hot and cold water outlets. Once correct boiling temperature is established, the Quadra recalibrates its internal settings and the display panel returns to normal.

Installation and Commission Checklist

- Filter packing foam removed from under filter cartridge.
- All other packaging films and labels removed.
- Dispenser mounted securely – M4 chrome retaining screw fitted.
- Dispenser swivels 45° in each direction (if activated) - locking piece is removed.
- Tubing is cut to correct lengths and not kinked or sagging. Red, grey and blue silicone tubes have a continual fall.
- Tubing not twisted or kinked.
- Tubing secured correctly – nuts and spring clips.
- Water main flushed before connection to unit.
- Unit connected to COLD water supply.
- Correct air clearances around unit.
- Power circuit fitted with an RCD – earth leakage protection device.
- Sawdust cleaned out of cupboard area.
- Initial program settings correctly set for dispenser tube length.
- Time (check if daylight savings), day and date set correctly – Refer to Quadra User Guide.
- Unit heating and cooling (after initial fill). Red and blue dispenser icons flashing (or on continually when reached correct temperature).
- Boiling and chilled water flowing correctly



Please scan the QR code for all support information.

Billi Australia Pty Ltd

P 1800 812 321
W www.billi.com.au

Billi New Zealand Ltd

P 0800 636 0 636
W www.billi.co.nz

Billi®

Designed and manufactured in Australia.

Billi® is a registered trademark of Billi Australia Pty Ltd. © Copyright protected.

Billi Australia Pty Ltd has a policy of continual improvement, all details are subject to change without notice. All goods are sold subject to our published terms and conditions.

Billi[®]