

ROCA L20 SINK MIXER

INSTALLATION INSTRUCTIONS

Important Note

Mixer must be installed to the requirements of AS/NZS 3500 by a qualified plumber. Your mixer comes to you already factory assembled and tested. We do not recommend the dismantling of any internal part of the mixer. The mixers are factory tested and sealed so as to give the best performance.

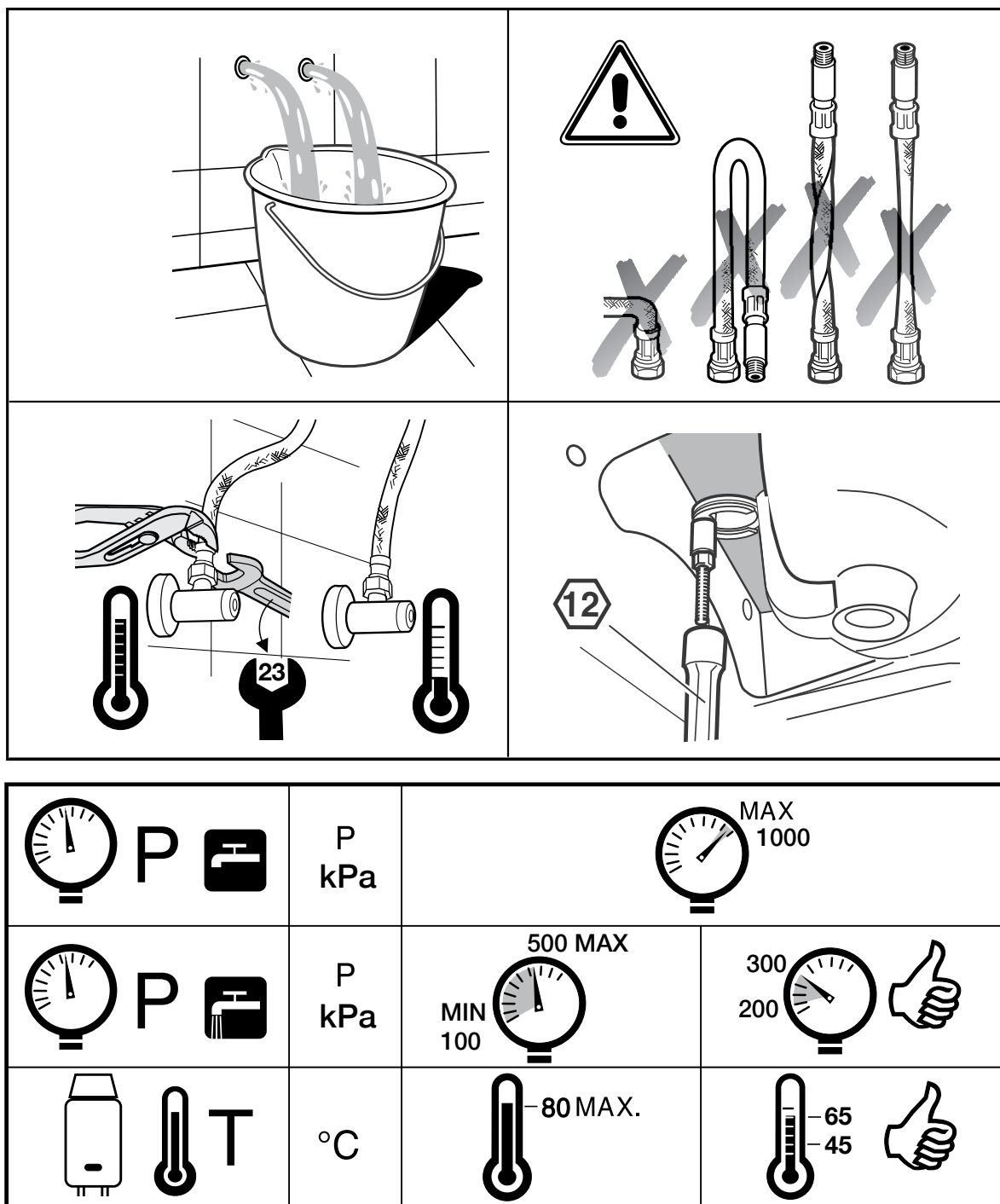

Plumbers, please ensure a copy of the installation instructions is left with the end user for future reference

ROCA

L20 SINK MIXER

INSTALLATION INSTRUCTIONS

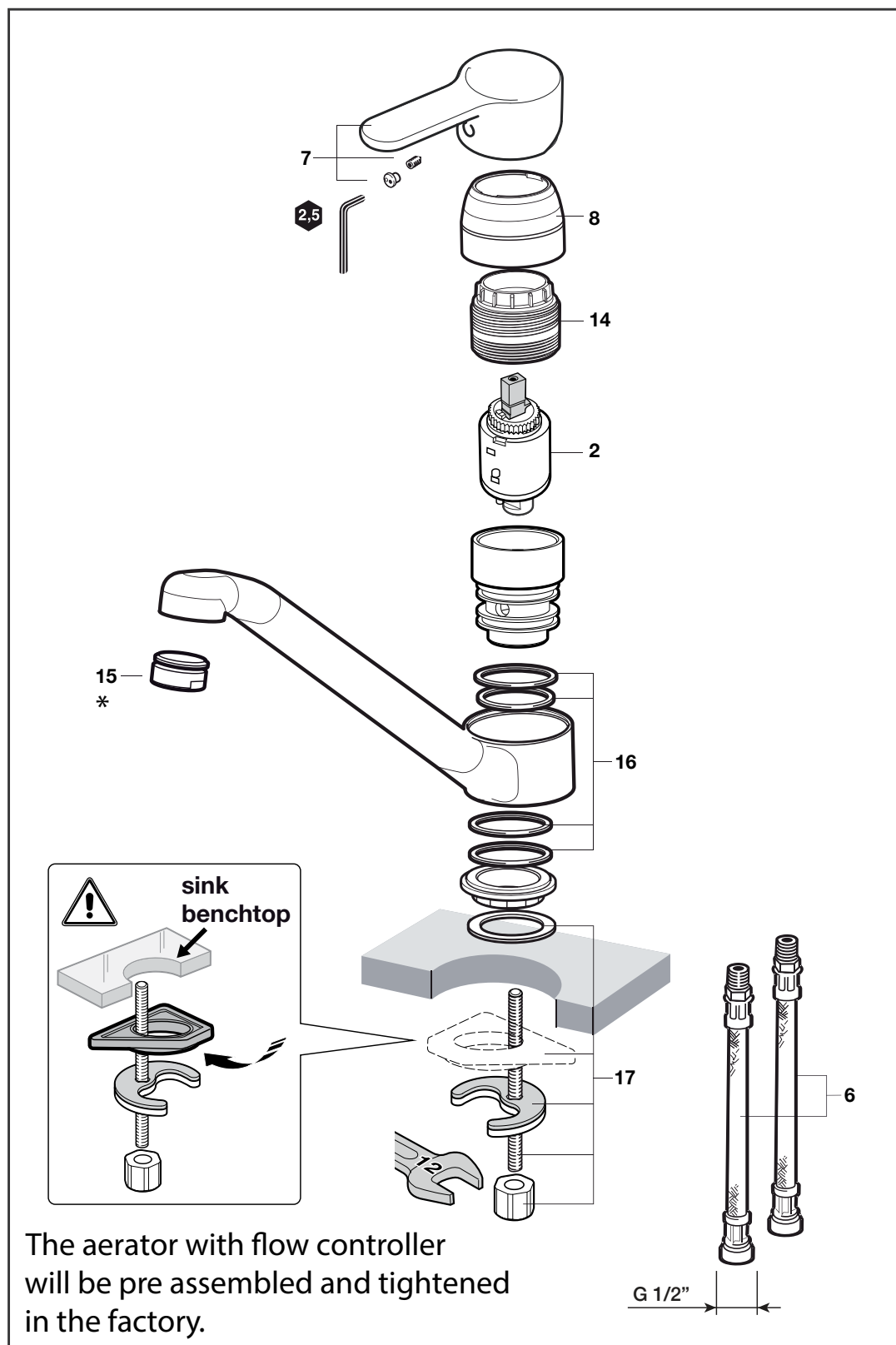

Plumbers, please ensure a copy of the installation instructions is left with the end user for future reference

ROCA L20 SINK MIXER

CLEANING INSTRUCTIONS

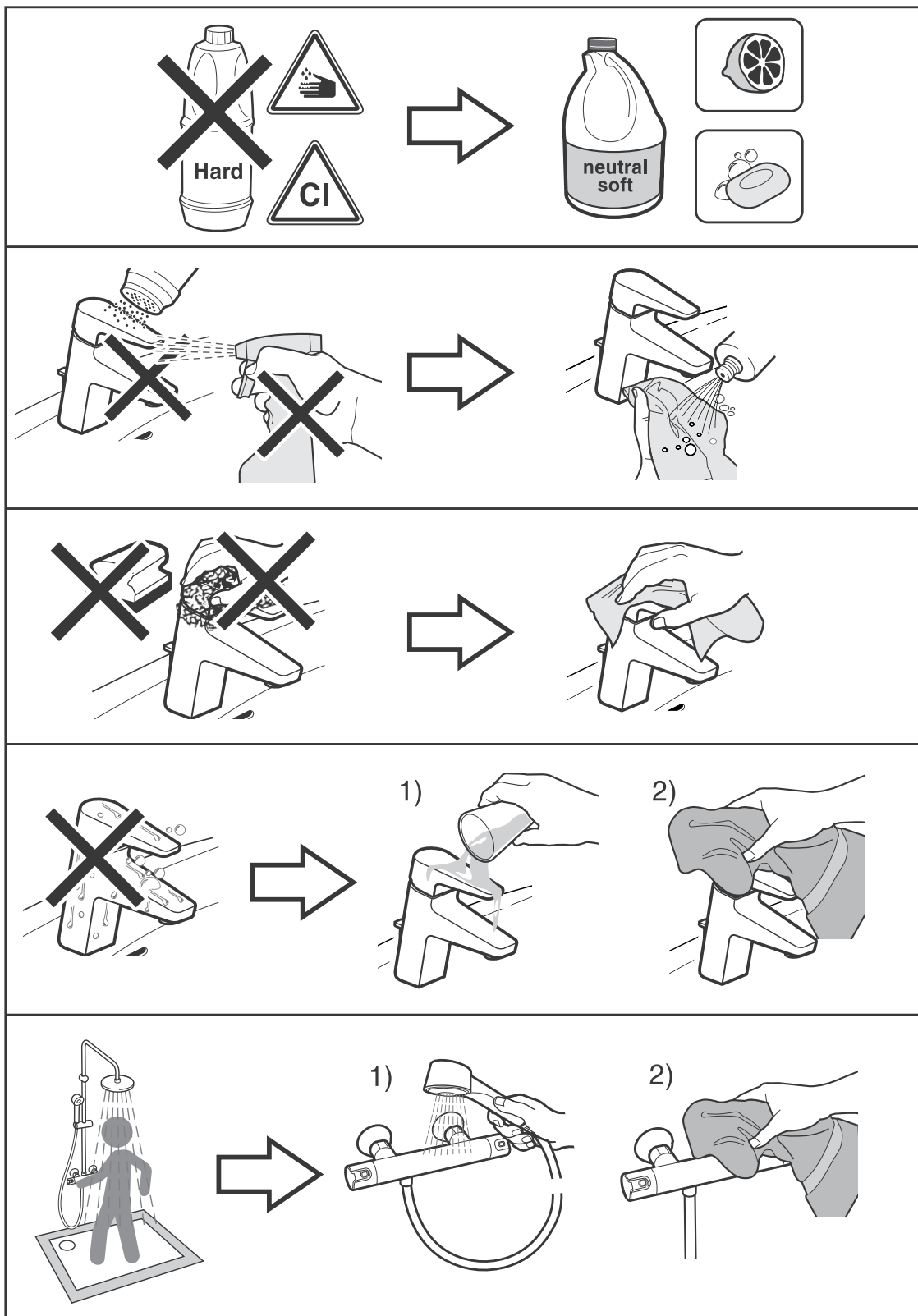

Plumbers, please ensure a copy of the installation instructions is left with the end user for future reference