

LAUFEN

LAUFEN Ino Wall Basin with Overflow & Fixing Bolts 1 Taphole 560mm White

9507785

SPECIFICATIONS

| | |
|-----------------------|------------------------|
| Recommended Use | Residential;Commercial |
| Primary Material | SaphirKeramik |
| Colour Finish | White |
| Bowl Capacity (L) | 5.9 |
| Weight (kg) | 9 |
| Taphole Configuration | One |
| Overflow Included | Yes |
| Plug & Waste Included | No |

WARRANTY

| | |
|--------------------------------------|----|
| Residential & Commercial Use (Years) | 25 |
| Spare Parts & Labour (Years) | 1 |

Please refer to LAUFEN Warranty page for full Terms and Conditions

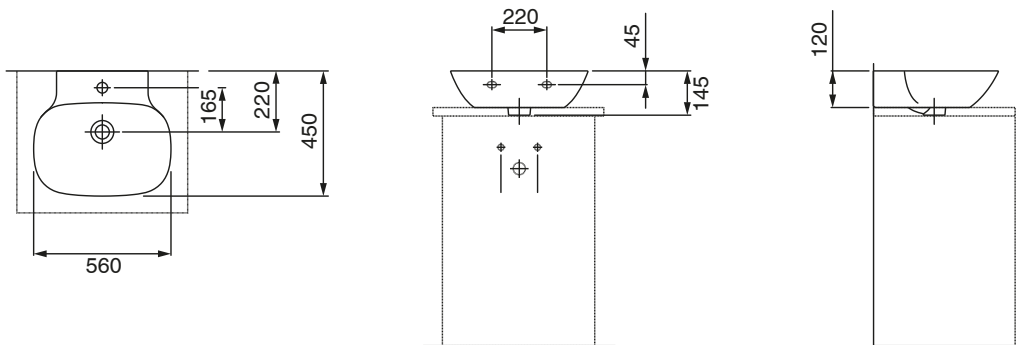

Dimensions are nominal measurements only.

CLEANING RECOMMENDATIONS:

We recommend the use of soapy water or approved cleaners. This product should not be cleaned with abrasive materials. Damage caused by any improper treatment is not covered by the product warranty. Refer to Warranty Conditions

Disclaimer: Products in this specification manual must by regulation be installed by licensed and registered trade people. The manufacturer/distributor reserves the right to vary specifications or delete models from their range without prior notification. Dimensions are nominal measurements only. Dimensions and set-outs listed are correct at time of publication however the manufacturer/distributor takes no responsibility for printing errors.

Published 23/04/2026

To see the complete LAUFEN range go to www.reece.com.au

