

# MILLI AXON

## WALL BATH SET

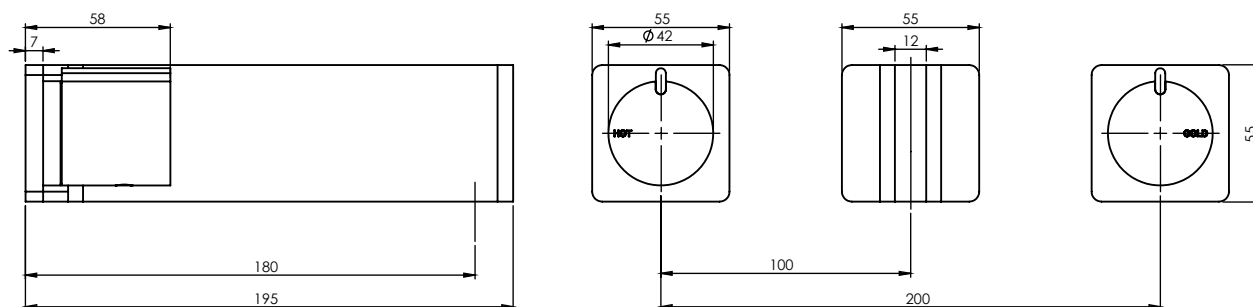

### SPECIFICATIONS

<b>Recommended Use</b>	Domestic, hotel and commercial
<b>Finish Available</b>	Chrome Handle with Chrome Outlet Chrome/Black Handle with Chrome Outlet Chrome/Black Handle with Black Outlet
<b>Pressure Rating</b>	Maximum continuous operating pressure 500 kPa. Note: For best performance and longer life we recommend 150-500 kPa.
<b>Temperature Rating</b>	Maximum continuous working temperature 75°
<b>Suitable Hot Water</b>	Storage Tank: No Continuous Flow: Refer to manufacturer of continuous hot water systems Gravity Feed: No
<b>Standards</b>	AS/NZS 3718



To see the complete Milli range go to [www.reece.com.au/bathrooms](http://www.reece.com.au/bathrooms)

### CLEANING RECOMMENDATIONS

This product should not be cleaned with abrasive materials eg. steel wool/scourers. Damage caused by any improper treatment is not covered by the product warranty - refer to Warranty Conditions.



**Disclaimer:** Products in this specification manual must by regulation be installed by licensed and registered trade people. The manufacturer/distributor reserves the right to vary specifications or delete models from their range without prior notification. Dimensions are nominal measurements only. Dimensions and set-outs listed are correct at time of publication however the manufacturer/distributor takes no responsibility for printing errors.

Tech Page Version 1

Milli

reece

# MILLI AXON WALL BATH SET

## INSTALLATION INSTRUCTIONS

**Milli Axon Wall Top Assemblies INSTALLATION INSTRUCTIONS**

### WATER SUPPLY REQUIREMENTS



**Recommended Working Pressure**



**Maximum hot water temperature**

**Note:**

- If the pressure exceeds or is likely to exceed 550kpa, an approved pressure limiting device must be installed.
- Flush out all pipe work prior to installation.
- If the water temperature exceeds 75°C, an approved tempering valve must be fitted.
- Installation should comply with Australian standard AS3500.1 or relevant local authority requirements.

Failure to comply with the above may void all warranties.

**Maintenance and Care**

- Chrome plated surfaces should be cleaned with mild liquid detergent or soap and water.
- **Do not** use cream cleaners or citrus based cleaning products, as they are abrasive.
- Use of unsuitable cleaning agents may damage the surface. Any damage caused in this way will not be covered by warranty.

**1** Check seats in Recessed Breach are in good condition and are free of foreign objects.

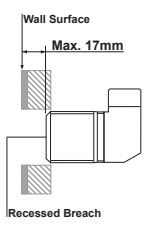

Recommended installation range for Recessed Breach as shown in diagram.

Reseat if required.

**2** Measure the distance from Recessed Breach to Wall Surface. Check against diagram below to determine which cartridge extension to be used in step 4.

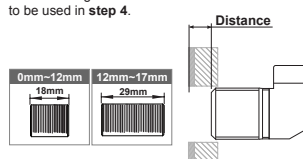

**3** Screw Cartridge into Recess until Cartridge seals with seat in Recess. **Do not over-tighten**

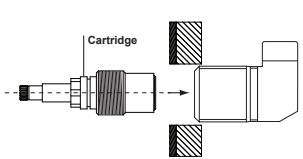

**4** Fit the cartridge extension onto the cartridge spindle. Fasten screw.

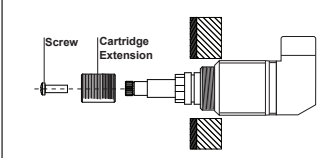

**5** Fit Red Fibre Washer around the cartridge. Fasten Bonnet onto the cartridge firmly with a spanner.

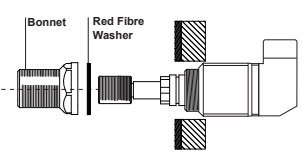

**6** Fit "O" Ring to Square Plate. Place Square Plate into position. Fasten Lock Nut to secure Square Plate.

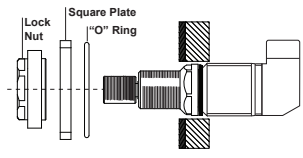

**8** Fit Nylon Washer into the groove of Lock Nut. Turn the cartridge clockwise until it stops at the "OFF" position.

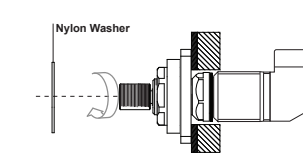

**9** Push on Handle over the cartridge extension. Fasten Grub Screw firmly, push in Screw Cap.

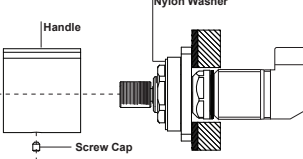

### Mixer Operation

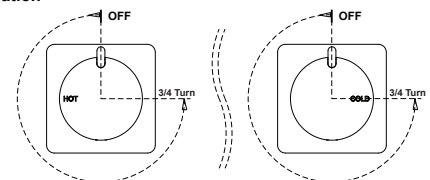

**NOTE :** The handle with hot marking must be on the left hand side as viewed from the users position.

# MILLI AXON WALL BATH SET

## INSTALLATION INSTRUCTIONS

### Milli Axon Wall Basin & Bath Outlet INSTALLATION INSTRUCTIONS

#### INSTALLATION INSTRUCTIONS

- 1 : Measure and cut Elbow Thread to Max. 12mm from the wall surface.  
*Ensure the elbow is not recessed into tiled surface.*
- 2 : Apply Teflon Tape to Elbow Thread.
- 3 : Ensure "O" Rings are fitted to Adaptor. Screw Adaptor to Elbow Thread firmly.
- 4 : Check if Gasket is fitted to the spout.
- 5 : Push Spout onto Adaptor. fasten Grub Screws.
- 6: **Test & Check for Leaks**

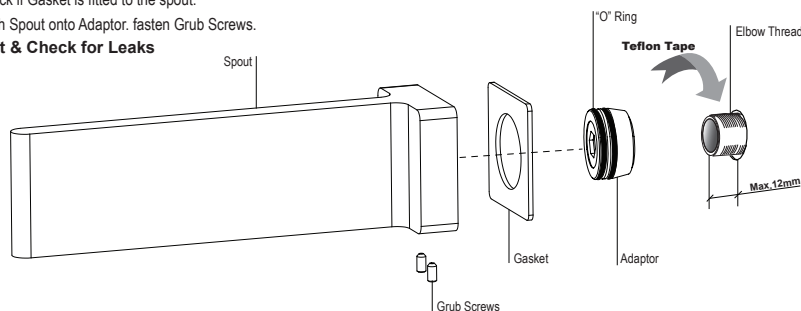

#### Removing The Aerator Retainer

Remove the screw. Place your hand underneath the aerator retainer. Turn on water gradually until the aerator retainer washes out onto your hand.

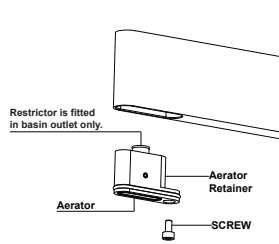

#### WATER SUPPLY REQUIREMENTS



#### Note:

- If the pressure exceeds or is likely to exceed 550kpa, an approved pressure limiting device must be installed.
  - Flush out all pipe work prior to installation.
  - If the water temperature exceeds 75°C, an approved tempering valve must be fitted.
  - Installation should comply with Australian standard AS3300.1 or relevant local authority requirements.
  - Showers may not be suitable for use with gravity-fed water heaters, low-pressure supply networks or some instantaneous water heaters.
- NOTE: Some showers with nominal flow rates of less than 7.5lt/min may not provide an effective shower when used with gravity-fed water heaters, low-pressure supply networks or some instantaneous water heaters.

Failure to comply with the above may void all warranties.

#### Maintenance and Care

- Chrome plated surfaces should be cleaned with mild liquid detergent or soap and water.
- Do not** use cream cleaners or citrus based cleaning products, as they are abrasive.
- Use of unsuitable cleaning agents may damage the surface. Any damage caused in this way will not be covered by warranty.