

Features & Benefits

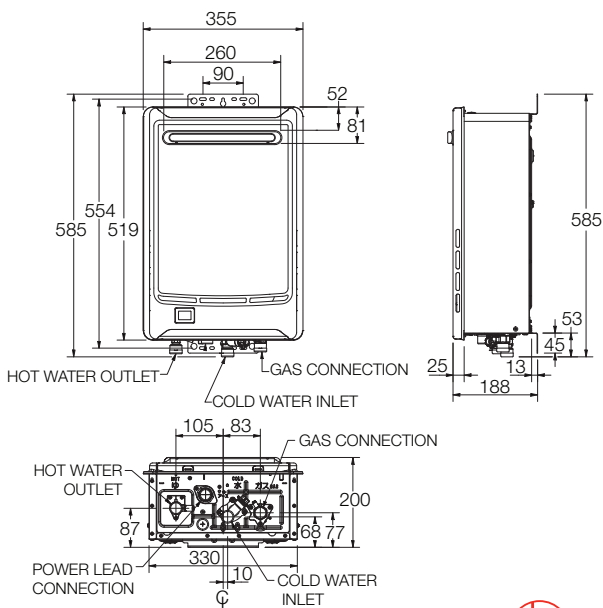

- 16 L/min continuous hot water delivery @ 25°C rise
- Remote Temperature Controller options
- 50°C models available (876A16), requiring no tempering valve³
- LED display for easy fault diagnosis
- Natural gas & Propane models
- Accessories: Pipe cover 299430, Recess Box 299427, Security Cage 299867, Wall Mount Security Kit 299868
- 12 year heat exchanger warranty¹



MODEL	876A16 874A16
Min. Operating Flow rate (L/min)	1.5
Nom. Gas Consumption (MJ/hr)	126
Max Water Supply Pressure (kPa)	1000
Min Water Supply Pressure (kPa)	120
Water Connections	R ³ / ₄
Gas Connection	R ³ / ₄
Approx. Weight (Empty) kg	16



Tap QR code for
installation
instructions

