

# Billi®

## Commercial User Guide

---

Installation Guide Billi Quadra  
& Billi Quadra Plus

(904010, 904020, 904025, 904040,  
904060, 904065, 904100, 904105,  
904107, 904180, 904187)

---

Dispenser Options:  
XT Motion, Multifunction Mixer  
Tap, & Plus Mixer Tap



## CONTENTS

<b>Warnings and Important Information</b>	<b>3</b>
<b>Warnings and Important Information</b>	<b>4</b>
<b>General Maintenance</b>	<b>4</b>
<b>Dispenser Care</b>	<b>4</b>
<b>Cupboard Ventilation Requirements</b>	<b>4</b>
<b>Features</b>	<b>5</b>
Dispenser Swivel	5
Safety Timeout	5
Childproof safety switch	5
Water delivery temperatures	5
Time switch	5
Standby Mode	5
<b>Dispenser Features</b>	<b>6</b>
XL Dispenser	6
XT, XR Dispenser	6
Multifunction Mixer Tap	6
XT Motion Dispenser	6
<b>Billi Quadra &amp; Quadra Plus - XL.</b>	<b>7</b>
<b>Billi Quadra &amp; Quadra Plus - XT, XR.</b>	<b>8</b>
<b>Multifunction Mixer Tap Icons</b>	<b>9</b>
<b>XT Motion Dispenser Icons</b>	<b>9</b>
<b>XT Motion Operating Instructions (Touchless)</b>	<b>10</b>
<b>User Settings</b>	<b>11</b>
<b>Set up Instructions</b>	<b>12</b>
Setting time and date	12
Setting time switch	12
Options	12
Statistics	12
Initial Setup	12
<b>Billi Filter Cartridges</b>	<b>13</b>
Filter Change Due Monitor	13
Replacement of Filter Cartridges	13
<b>Filter removal and replacement instructions</b>	<b>14</b>
<b>Billi Quadra Plus</b>	<b>15</b>
<b>Service Support</b>	<b>15</b>

## Warnings and Important Information

- For continued safety of this appliance, it must be installed, operated, and maintained in accordance with the manufacturer's instructions.
- Your appliance should be installed by the manufacturer, a service agent, or any other suitably qualified tradesperson.
- For correct operation of this appliance, it is essential to observe the instructions as outlined in this booklet.
- Do not use this appliance with water that is microbiologically unsafe or with water of unknown quality without adequate disinfection before or after the system. Systems certified for cyst reduction may be used on disinfected water that may contain filterable cysts.
- Filter replacement must be performed at intervals of not more than 12 months.
- Use this appliance only as directed in these instructions and only for its designed purpose.
- This appliance is not intended for use by persons (including children) with reduced physical, sensory or mental capabilities, or persons with lack of experience and knowledge, unless they are supervised or have been given instruction concerning use by a person responsible for their safety.
- This appliance is not to be installed in an area where a water jet could be used.
- Children should be supervised to ensure that they do not play with the appliance.
- **DANGER:** The operation of the thermal cut-out indicates a possibly dangerous situation. Do not reset the thermal cut-out until the water heater has been serviced by a suitably qualified person.
- **WARNING:** Do not connect any restrictor or pressure relief device to the vent pipe of this water heater if installed.
- If the supply cord is damaged, it must be replaced by the manufacturer, its service agent or similarly qualified persons in order to avoid creation of a hazard.
- **WARNING:** When positioning the appliance ensure the power supply cord is not trapped or damaged.
- **WARNING:** Avoid spillages of any kind on all electrical connectors.
- **WARNING:** Potential injury can result from misuse.
- **WARNING:** Heating element surface is subject to residual heat after use.
- Billi hose sets as supplied with the appliance are to be used. Old or other manufacturers' hose sets should not be re-used.
- **WARNING:** This appliance may deliver water at high temperature. Refer to the plumbing code of Australia (PCA), local requirements and installation instructions to determine if additional temperature control is required.
- **WARNING:** Installation shall conform to the plumbing code of Australia (PCA) or relevant local requirements.
- If the appliance is located where the ambient air temperature could fall below 4°C when the heater is not in use, do not turn off the power supply to the appliance. This safeguard does not offer the same protection to the connecting pipework and fittings.
- The ambient temperatures this unit should operate within are 4°C to 45°C.
- Turn off power to unit, by unplugging the power cord from the power point, if water supply is turned off.
  - The appliance is intended to be used in household and similar applications such as:
  - Staff kitchen areas in shops, offices and other working environments
  - Farmhouses and by clients in hotels, motels and other residential type environments
  - Bed and breakfast type environments
  - Catering and similar non-retail applications
- **WARNING:** When positioning the appliance, ensure the supply cord is not trapped or damaged.
- **WARNING:** Do not locate multiple portable socket - outlets or portable power supplies at the rear of the appliance.

Please note maximum water inlet pressure is 1000K Pa

---

## Warnings and Important Information

---

Boiling water is dangerous and can cause severe burns, particularly with young children. Boiling water must always be handled with caution. Use this appliance only as directed in these instructions and only for the purpose for which it has been designed.

Your Quadra & Quadra Plus is designed to be safe and practical. In an environment with young children, it is recommended that the boiling water safety switch is activated. The following safety features have been included:

- Ergonomic levers (XL)
- Levers/touch activations located safely above water outlet.
- Smooth electronically controlled boiling water flow rate. Flow is briefly reduced as water first enters the cup to prevent splashing.
- Dispenser remains cool to touch.
- Childproof safety switch.
- Boiling water Safety Isolation mode.

---

## General Maintenance

---

Your Billi Quadra has been designed to require minimal maintenance other than replacement of filter cartridges.

During each filter change, check all water connection fittings for signs of leakage. Check all tubing for any signs of damage. Check the cupboard area around the base of the unit for any signs of moisture.

Ensure side vents of the underbench module are kept clear, and airflow is not obstructed. Restricted airflow will cause inefficient operation of the refrigeration system.

---

## Dispenser Care

---

Proper care of Billi electronic dispensers is crucial to prevent premature wear of surface finishes and to ensure reliable dispense operation.

Avoid using abrasive cleaners on any external surfaces of the dispenser. Wipe clean only using damp cloth. Use of a nonsolvent, non-smearing cleaner such as Windex is recommended. DO NOT pour water directly over the dispenser.

---

## Cupboard Ventilation Requirements

---

Your water-cooled Billi Quadra underbench module requires no cupboard ventilation but requires clear movement space around the unit of 10mm. Care should be taken when using the cupboard space, to avoid stretching or damaging plastic pipe work. Check fittings and tubing at each filter change for signs of damage or leakage. Always ensure access to power switch and water supply tap is not restricted.



## Features

---

### **Dispenser Swivel**

The XL, XT and XR dispenser incorporates a swivel function, allowing the dispenser to be swung out of the way if more sink space is required. A central position stop provides a positive location during normal usage.

### **Safety Timeout**

Your Billi Quadra incorporates a water delivery Safety Timeout to prevent an uncontrolled flow of water. Water flow stops automatically after a set time interval. Flow can be started again by releasing and pressing the dispenser lever or button. Boiling water timeout – 10 secs; Chilled water – 1 minute.

### **Childproof safety switch**

Your Billi Quadra is fitted with a childproof safety lock-out feature to protect against accidental dispensing of boiling water and the risk of burns. Please refer to page 11 to set up.

### **Water delivery temperatures**

The boiling and chilled water temperatures can be adjusted to suit individual preferences. Hot water temperature range: 80°C – 98 .9°C. Cold water temperature range: 6°C – 20°C.

### **Time switch**

Your Billi Quadra incorporates an energy-saving time switch. This function allows the Quadra to automatically turn ON and OFF at selected times. Individual days can be set to be active or non-active. The green lightning bolt indicates that the time switch is set. Refer to Setting Instructions, page 9.

### **Standby Mode**

An energy saving Standby mode can be selected to activate after a period of non-use. Once activated, the boiling water temperature can drop to 80°C and the chilled water temperature can rise to 15°C. A touch of either dispenser lever or button cancels the standby and the Quadra resumes its normal operating mode to deliver boiling or chilled water. The time needed to elapse before the Quadra enters this mode can vary. During Standby mode, the green moon and stars icon will be illuminated. Refer to Options, page 9.

---

## Dispenser Features

---

### **XL Dispenser**

The XL dispenser is simply operated with position-sensitive levers.

The red dot on the left indicates the boiling water lever, and the blue dot on the right indicates the chilled water lever.

Both levers can either be lifted or depressed. When lifted, the levers will latch for continuous delivery until released with a light press.

The XL dispenser incorporates a swivel function, allowing the dispenser to be swung 45 ° in either direction if more sink space is required.

A central position stop provides position location during usage. To enable the swivel feature, the locking piece needs to be removed as per the dispenser installation instructions.

### **XT, XR Dispenser**

The XT and XR dispenser are operated with capacitive touch buttons. Red and blue buttons indicate boiling and chilled water.

Red and blue buttons can be pressed and held for momentary dispensing or double tapped for continuous flow. Water will not flow if both buttons are held together.

### **Multifunction Mixer Tap**

The Multifunction mixer tap incorporates both filtered and mains mixer water functionality in one tap.

Filtered water dispense is operated with capacitive touch buttons on the left side of the tap. Red, and blue, buttons indicate boiling, and chilled water dispense.

Buttons can be pressed and held for momentary dispensing or double tapped for continuous delivery until stopped by pressing either of the boiling, or chilled buttons.

Mains mixer water is operated using the mixer lever on the right side of the tap.

### **XT Motion Dispenser**

The XT Motion dispenser delivers boiling, and chilled filtered water through an integrated dual-control interface that supports both touch and touch-free activation. The system allows users to dispense water with precision and safety using motion control, while enhancing hygiene and usability in high-use environments.

Filtered water dispense is operated with capacitive touch buttons on the top of the tap. Red, and blue buttons indicate boiling, and chilled water dispense.

Buttons can be pressed and held for momentary dispensing or activated by touch-free motion. Double tap the corresponding buttons to dispense water continuously.

## XL Dispenser Icons



### **Orange dot.**

Flashes when filter change is due. On constant when overdue.

### **Red lock illuminated.**

Safety button is activated. To use, press the indent on the back of the tap momentarily & lift or press the boiling lever.

### **Green leaf illuminated.**

Eco intelligence.

### **Green moon & stars illuminated.**

In holiday mode. Red & blue icons will not be displayed in this mode.

### **Green moon & stars flashing**

In standby mode. Red & blue icons will not be displayed in this mode.

### **Red dot.**

Flashes when heating up to temperature. On constant when boiling water is ready, Off when in holiday or standby mode.

### **Blue dot.**

Flashes when chilling. On constant when chilled water ready. Off when in holiday or standby mode. Red & blue dots will flash yellow if the unit goes into fault.

## XT & XR Dispenser Icons



### **Orange dot.**

Flashes when filter change due. On constant when overdue.

### **Red lock illuminated.**

Safety button activated. To use, press the indent on the top of the tap momentarily & lift or press the red button.

### **Green leaf illuminated.**

Eco intelligence.

### **Green moon & stars illuminated.**

In holiday mode. Red & blue icons will not be displayed in this mode.

### **Green moon & stars flashing**

In standby mode. Red & blue icons will not be displayed in this mode.

### **Red ring.**

Flashes when heating up to temperature. On constant when boiling water is ready, Off when in holiday or standby mode.

### **Blue ring.**

Flashes when chilling. On constant when chilled water ready. Off when in holiday or standby mode.

Red & blue rings will flash yellow if the unit goes into fault.



### **Orange dot.**

Flashes when filter change due. On constant when overdue.

### **Red lock illuminated.**

Safety button activated. To use, press the indent on the top of the tap momentarily & lift or press the red button.

### **Green leaf illuminated.**

Eco intelligence.

### **Green moon & stars illuminated.**

In holiday mode. Red & blue icons will not be displayed in this mode.

### **Green moon & stars flashing**

In standby mode. Red & blue icons will not be displayed in this mode.

### **Red ring.**

Flashes when heating up to temperature. On constant when boiling water is ready, Off when in holiday or standby mode.

### **Blue ring.**

Flashes when chilling. On constant when chilled water ready. Off when in holiday or standby mode.

Red & blue rings will flash yellow if the unit goes into fault.

## Multifunction Mixer Tap Icons



### Red Lock Illuminated

Childproof Safety Lock is on. To unlock press the red lock icon. Lock turns green when unlocked.

### Orange Ring Icon

Appears & flashes when filter change is due. On constant when overdue.

### Blue Chilled Icon

Flashes when chilling. On constant when chilled water is ready. Switches off when energy saving mode is activated by either the standby feature or the time switch feature. Flashes yellow when unit goes into fault.

### Red Boiling Icon

Flashes when heating up to temperature. Will flash faster when approaching temperature setpoint. On constant when boiling water is ready. Switches off when energy saving mode is activated by either the standby feature or the time switch feature. Flashes yellow when unit goes into fault.

## XT Motion Dispenser Icons



### Red Lock Illuminated

Childproof Safety Lock is on. To unlock press the red lock icon. Lock turns green when unlocked.

### Orange Ring Icon

Appears & flashes when filter change is due. On constant when overdue.

### Blue Chilled Icon

Flashes when chilling. On constant when chilled water is ready. Switches off when energy saving mode is activated by either the standby feature or the time switch feature. Flashes yellow when unit goes into fault.

### Red Boiling Icon

Flashes when heating up to temperature. Will flash faster when approaching temperature setpoint. On constant when boiling water is ready. Switches off when energy saving mode is activated by either the standby feature or the time switch feature. Flashes yellow when unit goes into fault.

## XT Motion Operating Instructions (Touchless)

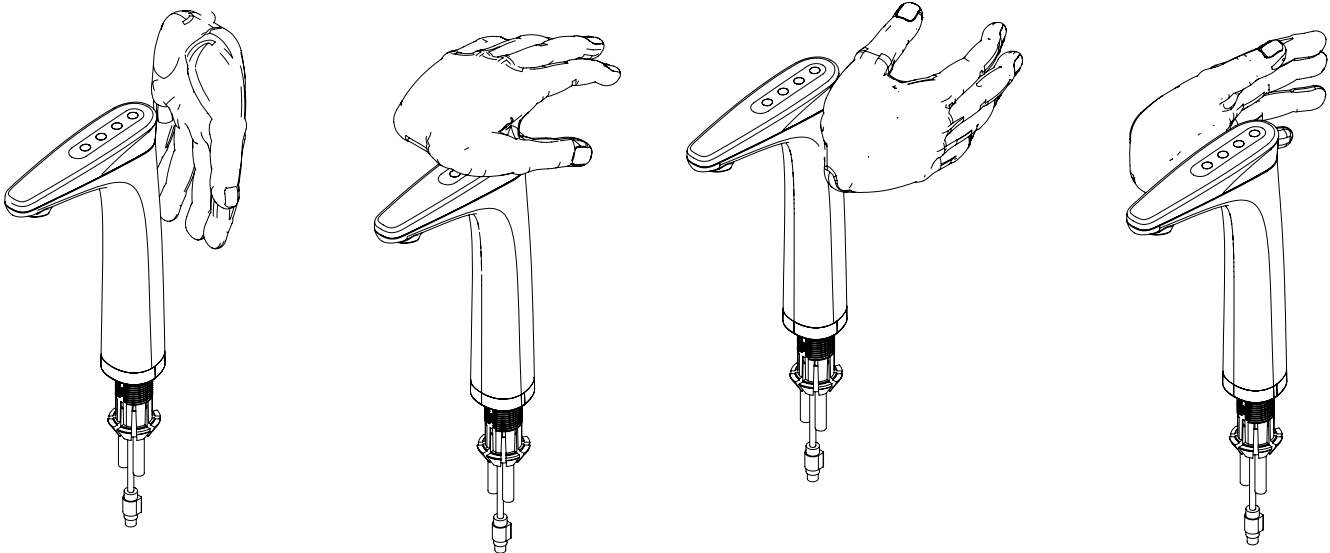

### Boiling Water - Touchless

1. Position your hand at the **rear of the tap body** (same gesture as an XL safety lock).
2. The **Safety Padlock** indicator will change from locked → unlocked.
3. Now hold your hand over the top of the boiling icon on the UI panel to begin dispensing.

### Sparkling Water - Touchless

1. Place your hand on the **left side** of the tap body.
2. Maintain your hand position to continue dispensing sparkling water.

### Chilled Water - Touchless

1. Place your hand on the right side of the tap body.
2. Maintain your hand position to dispense chilled water.

Note: Boiling water can only be dispensed when the Boiling Water Safety Lock is disengaged.

- If the safety lock is disengaged using the tactile method, boiling water can only be dispensed using the tactile method.
- If the safety lock is disengaged using the touchless method, boiling water can be dispensed using tactile or touchless method.

## User Settings

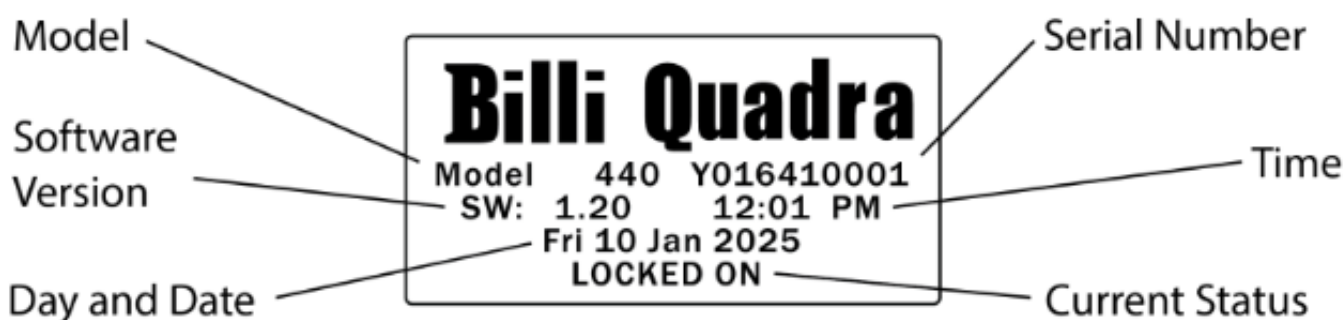
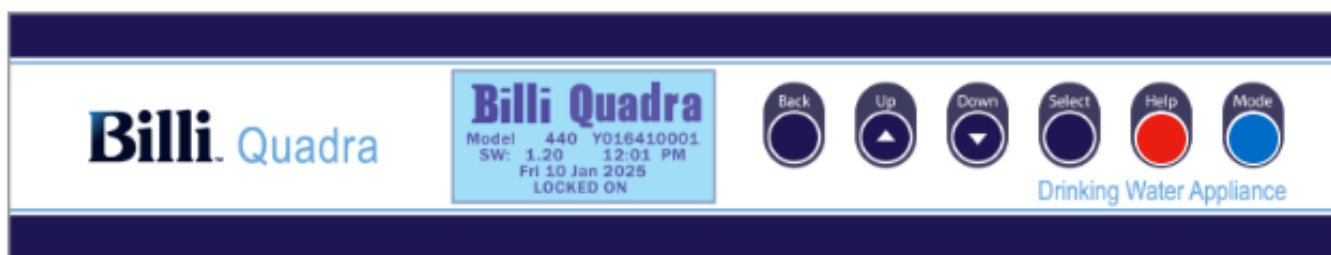

**Normal Display** Current status may be displayed as follows

<b>TIMESWITCH ON/OFF</b>	Indicates the Quadra has been switched ON or OFF by the inbuilt time switch control. During OFF mode, the dispenser icons are off and give a brief orange flash once every 10 seconds.
<b>OVERRIDE ON/OFF</b>	The Quadra can be manually turned ON or OFF by pressing the ● Mode button. The status remains selected for a period of 2 hours, after which it returns to automatic ON/OFF control.
<b>LOCKED ON/OFF</b>	The ON/OFF status can be permanently locked ON or OFF. Use ON if 24 hours, 7 days a week service is required; or OFF if user is going away for an extended period. To activate or deactivate: press the ● Mode button and hold down until the required status is displayed.
<b>SAFETY SWITCH</b>	The child proof safety Switch mode has been activated. To set, refer to Options, page 7.
<b>STANDBY</b>	A period of non-use has elapsed, and the Quadra has switched to the energy saving standby mode.

### Daylight saving

Time adjustment for daylight saving is made by pressing either the START or FINISH buttons at the beginning or end of daylight saving.

### Menu

- To access the menu, press the ● SELECT button. The menu functions are:
- To move the highlighted cursor, press the ▲ or ▼ buttons.
- To activate the highlighted cursor, press ● SELECT
- To return to the previous screen, press ● BACK

## Set up Instructions

---

### Setting time and date

- The screen shows currently set time, day and date.
- Press ▲ or ▼ buttons to move the highlighted cursor.
- Press ● SELECT to activate. The highlighted item flashes.
- When flashing, press ▲ or ▼ to change the setting.
- Press ● SELECT. The highlighted cursor stops flashing. The cursor automatically advances to next setting. Repeat the activation procedure above.
- Press ● BACK once to return to previous screen or twice to return to normal display.

### Setting time switch

The screen shows active and non-active days. Turn-on and Turn-off times for active days are displayed.

- Press ▲ or ▼ buttons to move the highlighted cursor.
- Press ● SELECT to activate. The highlighted item flashes.
- When flashing, press ▲ or ▼ to change the settings.
- Press ● SELECT to confirm and advance to the next setting. Repeat the activation procedure above.
- Press ● BACK twice to return to normal display.

### Options

The screen displays the following options and settings. Press ▲ or ▼ and ● buttons to select and activate or alter the required settings.

- Safety Switch: Childproof safety switch is activated by selecting ON.
- Hot Temp Set: Hot water temperature can be set between 80°C and 98.9°C.
- Cold Temp Set: Cold water temperature can be set between 6°C and 20°C.
- Standby Mode: Activated by selecting ON.
- Standby Time Set: Period of non-use before standby mode is activated. Range 0.5 to 4.0 hours.
- Filter Flush: Automatic flush cycle to clean filters after 2 days of non-use.
- 

### Statistics

The screen displays information only.

- Hot, Cold: Temperature of boiling and chilled water.
- Hot Cups: Total number of boiling water cups dispensed.
- Cold Cups: Total number of cold-water cups dispensed.
- Filter Life Remaining: No. of cups or days to go before changing filter warning flashes.
- Cups this filter: Cups current filter has been dispensed.
- Start: Date unit began to be used.
- S/W: Software version installed.

### Initial Setup

For use only by the installer when setting initial operating parameters.

## Billi Filter Cartridges

---

All Billi Quadra models feature the Billi swing-change filtration system. The Quadra is fitted with a single filter. The filters use Fibron™ technology, which is fibrous and matted together, increasing the surface area of the carbon, meaning there is greater contact time and improved quality of filtration. It incorporates five stage filtrations, removing sediment and chemical elements as well as enabling minerals to flow through the appliance without allowing scales build up and arresting the growth of bacterial microorganisms such as giardia and cryptosporidium.

Use only genuine filters as designed for this system. All drinking water filtration systems should be flushed after a period of non-use. Your Billi Quadra has an automatic flushing cycle which can be activated. Refer to the Options above. After a period of non-use of more than two days, e.g. OFF Saturday and Sunday, the cold water will flow for 90 seconds when the time switch first turns the unit on. Alternatively, before use, flush and run until water flow stops, then release the lever. \*(subject to water quality).

### Filter Change Due Monitor

The Quadra filter change due monitor operates by counting the number of cups dispensed and the number of days elapsed until a pre-set level is reached. Once reached, the dispenser icons will briefly change to orange once every five seconds. The Quadra will continue to operate while the filter indicator is flashing. Water filters installed in areas with higher levels of turbidity (cloudiness/sediment) will experience a reduced service life. The flow from the cold-water outlet will decrease as the filters become blocked. It may be necessary to change filters before the change filter indicator flashes. The filter monitor can be reprogrammed to an appropriate service interval if required. Contact Billi Australia Pty Ltd. Standard 5 micron-rated filters generally have a longer service life than Premium sub-micron-rated filters. If particularly dirty water is noticed coming through the water supply, e.g. from other tapware, as sometimes occurs following repairs to local water mains, immediately turn your Billi Quadra off using the Mode button. This will help prevent premature blocking of filter cartridges.

### Replacement of Filter Cartridges

Periodic replacement of your Billi Quadra's Water Filter Cartridges is necessary to maintain the sparkling cleanliness and purity of your drinking water. A replacement filter change service is available. To arrange, contact the Billi Service Centre on **1800 812 321**. If you wish to install the replacement filter cartridges yourself, filters can be purchased online at [www.billi.com.au](http://www.billi.com.au) or through a certified agent which will provide genuine Billi replacement cartridge sets. To assist with the replacement of your Quadra filter cartridge, a series of moving graphic instruction screens will guide you through the required steps. Press HELP if display indicates 'Filter Change Due'. Once the new filter has been installed and the filter flush cycle is complete, check for any water leakage around the filter system. Take particular care to ensure the area around the water leakage sensor, located on the lower left-hand side of the bulkhead behind the filters, is dry. If you have any questions or concerns during the filter change process, simply contact Billi's experienced technical Assistance Team on **1800 812 321**.

If you wish to install the replacement filter cartridges yourself, filters can be purchased online at [www.billi.com.au/billi-shop](http://www.billi.com.au/billi-shop) or by scanning the QR code at the footer of last page and on the back of this booklet.

## Filter removal and replacement instructions

**Important note:** Please ensure you remove the foam packing under the filter before installing.

1. Remove the front cover (see Diagram 1).
2. Press & hold the ON/OFF button until the LCD screen says OVERRIDE OFF. Leave the power supply on.
3. Remove the filter (and filter bypass insert if required) (see Diagram 2).
  - a. Hold the bottom of the filter (and filter bypass insert if required) and pull towards you slowly. The top of the filter is a hinged cradle assembly. It should stop after approximately 30 degrees of travel.
  - b. Pull it down until it pops out.
4. If water spills in the tray at the base of the filter, soak it up with a cloth or sponge.
5. If a single filter fits the new filter by pushing right up into the cradle & pushing back until it locks into place.
6. Units will now begin an automatic flush cycle.
7. Check for any leaks from around the filter, hosing or pipework.
8. Replace the front cover.
9. Once the lights stop flashing, your system is ready to use.

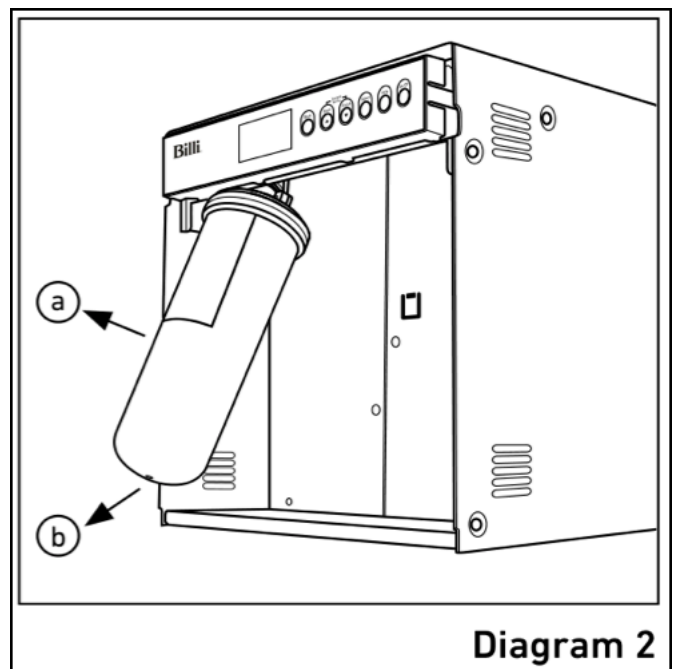
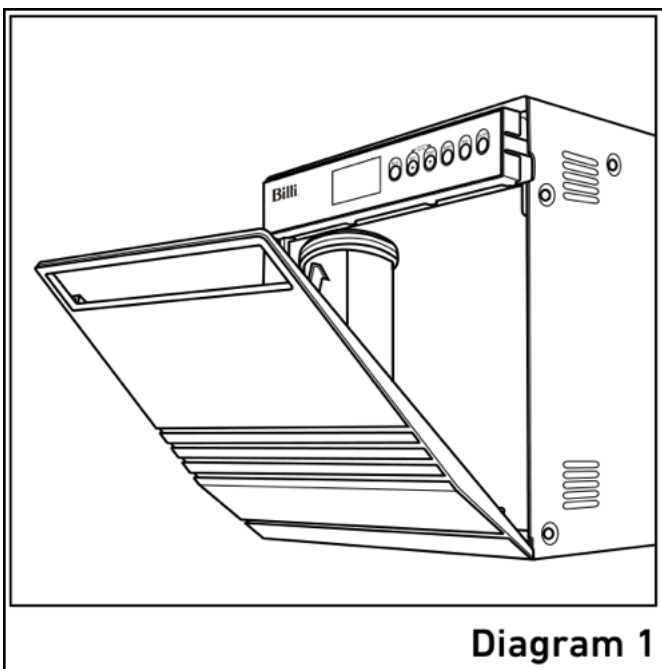

## Billi Quadra Plus

If you have installed a Billi Quadra Plus 5, Plus 9, or Plus 15, you will enjoy the benefit of instant hot water from your sink mixer tapware. When delivering hot water, the Quadra Plus draws boiling water from the internal storage tank, pre-mixing it with cold water, to deliver hot water up to 50°C. If the delivery capacity of the system is exceeded, the hot water will run cold with bubbling being evident. At this point, there is still extra boiling water available for delivery from the Quadra dispenser. Recovery is rapid, and additional hot water will be available after a short period of time.

## Service Support

Your Billi Quadra incorporates a fault detection and diagnosis system. Should a fault occur, a message will be displayed describing the fault. Pressing the HELP button will advise you of any checks that can be performed.

If a service call needs to be logged in, note the message displayed and report this when booking the call. This will assist the technician in coming prepared to rectify the problem.

For information on our filtration and service contract please contact:

Billi Head Office on 1800 812 321

E-mail (Australia/NZ): [service@billi.com.au](mailto:service@billi.com.au).

Email (International sales): [international.sales@billi.com.au](mailto:international.sales@billi.com.au)

For technical support please call: 1800 812 321 and speak to one of Billi's experienced technicians.

Filter cartridges are also available for purchase online at [www.billi.com.au](http://www.billi.com.au)



Please scan the QR code for all support information.

**Billi Australia Pty Ltd**

**P** 1800 812 321  
**W** [www.billi.com.au](http://www.billi.com.au)

**Billi New Zealand Ltd**

**P** 0800 636 0 636  
**W** [www.billi.co.nz](http://www.billi.co.nz)

# Billi®

Designed and manufactured in Australia.

Billi® is a registered trademark of Billi Australia Pty Ltd. © Copyright protected.

Billi Australia Pty Ltd has a policy of continual improvement, all details are subject to change without notice. All goods are sold subject to our published terms and conditions.

**Billi**<sup>®</sup>